

TECHNICAL MANUAL

**DIRECT SUPPORT, GENERAL SUPPORT,
AND DEPOT
MAINTENANCE MANUAL
INCLUDING REPAIR PARTS AND SPECIAL TOOLS LISTS
RADIO SET AN/PRC-47**

This copy is a reprint which includes current pages from Changes 1 and 2.

**HEADQUARTERS DEPARTMENT OF THE ARMY
NOVEMBER 1974**

WARNING

Avoid contact with the high-voltage circuits and the antenna terminal of the radio transmitter-receiver while performing trouble isolation procedures personal injury may result.

WARNING

The 650- and 1500-volts potentials at the power amplifier screen and plate electrodes are extremely dangerous. Avoid contact with these circuits.

WARNING

Place the POWER-LIGHTS switch to POWER OFF, disconnect the primary power source cable from the front of RT-671/PRC-47, and discharge the plate circuit capacitors and high-voltage filter capacitors in the power supply before proceeding with the following test. Personal injury or death can result from these dangerous voltages.

WARNING

Avoid contact with the high-voltage circuits of Signal Data translator CV-1377A/PRC-47 (A3), Power Supply PP-3518/PRC-47 (A5). and in the power amplifier compartment. These voltages can cause personal injury or death.

WARNING

Before removing any equipment cover or module from Radio Receiver-Transmitter RT-671/PRC-47, disconnect all power from the unit.

WARNING

High voltages are present in the circuits associated with Signal Data Translator CV-1377A/PRC-47, Power Supply PP-3518/PRC-47, and the power amplifier compartment. These voltages are dangerous and can cause personal injury or death. Ground the two high-voltage terminals on the main chassis (J1-A1 and J1-A2) to discharge the capacitors in the high voltage circuits before beginning maintenance within the chassis or inside any module.

WARNING

Before further disassembly, short-circuit connector pins P1-A1 and P1-A2 to ground to discharge the high-voltage filter capacitors. Personal injury or death can result from these voltages.

WARNING

High voltages are present on circuit components associated with the power amplifier stage. These voltages are dangerous and can be fatal. Before beginning tube replacement, ground the two high-voltage terminals (J1-A1 and J1-A2) on the main chassis to discharge the filter capacitors in this equipment.

**Direct Support, General Support and
Depot Maintenance Manual
(Including Repair Parts and Special Tools List)
RADIO SET AN/PRC-47**

	Paragraph	Page
CHAPTER 1. INTRODUCTION		
Scope	1-1	1-1
Indexes of publications	1-2	1-1
Reporting of errors	1-3	1-1
Reporting equipment improvement recommendations (EIR).....	1-3.1	
Administrative storage	1-3.2	
Destruction of Army electronics materiel	1-3.3	
Historical revisions to equipment	1-4	
2. FUNCTION OF EQUIPMENT		
Section I. System Function		
System applications	2-1	2-1
Block diagram explanations	2-2	2-1
Overall block diagram	2-3	2-1
General description	2-4	2-3
Receive signal path ..	2-5	2-8
Transmit signal path	2-6	2-9
Frequency control circuits ..	2-7	2-9
Power supply circuits	2-8	2-12
Section II. Theory of Receiver-Transmitter Operation		
Audio Frequency Amplifier		
AM-3506/PRC-47 (A8A1)	2-9	2-14
Amplifier-Modulator		
AM-3507/PRC-47 (A8A2)	2-10	2-18
Signal Data Translator		
CV-1377A/PRC-47 (A8A3)	2-11	2-21
Power Supply PP-3518/PRC-47 (A8A5)	2-12	2-27
Radio Frequency Oscillator		
O-1032/PRC-47 (A8A6)	2-13	2-28
Oscillator Control		
C-4311/PRC-47 (A8A7)	2-14	2-29
Electrical Equipment Chassis.....		
CH-474/PRC-47 (A8A4)	2-15	2-31
CHAPTER 3. DIRECT SUPPORT MAINTENANCE		
Section I. General Troubleshooting Techniques		
Scope	3-1	3-1
Tools, test equipment, and materials required	3-2	3-2
Section II. Direct Support Troubleshooting.....		
Overall troubleshooting	3-3	3-3
Troubleshooting Radio Receiver-Transmitter RT-671/PRC-47 (A8)	3-4	3-3
Localizing Tests	3-5	3-75
Section III. Isolating Trouble		
Trouble isolation within a module	3-6	3-87
Dc resistance of coils and transformer windings	3-7	3-88
Section IV. Repair		
General parts replacement techniques	3-8	3-95
General removal and replacement procedures	3-9	3-96
Section V. Assembly and Disassembly		
General	3-10	3-97
Removal and replacement of receiver-transmitter case	3-11	3-97

***This manual supersedes TM 11-5820-509-35, 20 November 1963, Including all changes.**

	Paragraph	Page
CHAPTER 3.	Direct Support Maintenance --Cont	
	Removal and replacement of plug-in modules	3-12 3-97
	Module assembly and disassembly procedures	3-13 3-98
	Power amplifier (A8A4A1) tube removal and replacement	3-14 3-103
	Power amplifier load-tune mechanism	3-15 3-104
	Frequency selection mechanism	3-16 3-107
	Power amplifier (A8A4A1) plate capacitor switch assembly	3-17 3-111
	Power amplifier (A8A4A1 XMTR PWR switch	3-18 3-112
	Main chassis and front panel removal and reassembly	3-19 3-114
Section VI.	Alignment and Adjustments	
	Test equipment and special tools required for alignment and adjustments	3-20 3-116
	Mechanical alignment of CV-1377A/PRC-47 slug rack coupler	3-21 3-124
	Receiver audio output adjustments	3-22 3-125
	Receiver agc circuit adjustments	3-23 3-125
	Transmitter sidetone adjustment	3-24 3-126
	Microphone amplifier gain adjustment	3-25 3-127
	Transmitter vox gain adjustment	3-26 3-127
	Power amplifier grid drive alignment and bias adjustments	3-27 3-128
	Temperature compensated oscillator frequency adjustment	3-28 3-129
	Balanced modular adjustments	3-29 3-130
CHAPTER 4.	GENERAL SUPPORT MAINTENANCE	
	General	4-1 4-1
	Test equipment required	4-2 4-1
	Test facilities	4-3 4-1
	Modification work orders	4-4 4-1
	Physical tests and inspection	4-5 4-1
	Receiver sensitivity tests	4-6 4-2
	Receiver avc characteristic test	4-7 4-4
	Receiver selectivity tests	4-8 4-5
	Receiver if rejection test	4-9 4-6
	Receiver image rejection test	4-10 4-6
	Receiver volume control test	4-11 4-7
	Receiver audio output distortion test	4-12 4-7
	Power input requirements, receive mode	4-13 4-8
	Transmitter power output test	4-14 4-9
	Transmitter output meter sensitivity test	4-15 4-13
	Transmitter frequency stability test	4-16 4-14
	Transmitter power input test	4-17 4-15
	Transmitter cw operation test	4-18 4-17
	Transmitter sidetone test	4-19 4-18
CHAPTER 5.	DEPOT MAINTENANCE	
	General	5-1 5-1
	Replacement of parts	5-2 5-1
	Equipment adjustments	5-3 5-1
	Transmit mixer balance and transmitter gain control adjustment	5-4 5-1
	Transmitter hum balance adjustment	5-5 5-2
	Transmitter modulation fidelity test	5-6 5-3
	Transmitter spurious output adjustments	5-7 5-4
CHAPTER 6.	DEPOT OVERHAUL STANDARDS	
Section I.	General	
	Scope	6-1 6-1
	General	6-2 6-1
	Test facilities	6-3 6-8
	Modification work orders	6-4 6-8
	Physical tests and inspection	6-5 6-8
	Reference standards tests	6-6 6-8
	Tests to be Performed	6-7 6-9
	Reference standards	6-8 6-9
Section II.	Performance Tests	
	General	6-9 6-13
	Audio Frequency Amplifier	
	AM-3506/PRC47 (A8A1)	6-10 6-13
	Amplifier-Modulator	
	AM-3507/PRC-47 (A8A2)	6-11 6-16

	Paragraph	Page
CHAPTER 6.	Depot Overhaul Standards-Cont.	
	Signal Data Translator	
	CV-1377A/PRC-47 (A8A3)	6-12 6-18
	Power Supply	
	PP-3518/PRC-47 (A8A51)	6-13 6-24
	Radio Frequency Oscillator	
	0-1032/PRC-47 (A8A6)	6-14 6-27
	Oscillator Control	
	C-4311/PRC-47 (A8A7)	6-15 6-31
Section III.	Special Test Fixtures	
	General	6-16 6-37
	Test Fixture for Audio Frequency Amplifier	
	AM 3506/PRC-47	6-17 6-37
	Test Fixture for Amplifier-Modulator	
	AM-3507/PRC-47	6-18 6-41
	Test Fixture for Signal Data Translator	
	CV-1377A/PRC-47	6-19 6-45
	Test Fixture for Power Supply	
	PP-3518/PRC-47	6-20 6-50
	Test Fixture for Radio Frequency Oscillator	
	0-1032/PRC-47	6-21 6-54
	Test Fixture for Oscillator Control	
	C-4311/PRC-47	6-22 6-56
CHAPTER 7.	CIRCUIT DIAGRAMS	
	Introduction	7-1 7-1
APPENDIX A.	REFERENCES	A-1
APPENDIX B.	DIRECT SUPPORT, GENERAL SUPPORT, AND DEPOT MAINTENANCE REPAIR PARTS AND SPECIAL TOOLS LIST	
Section I.	Introduction	
	Scope	B-1 B-1
	General	B-2 B-1
	Explanation of columns	B-3 B-1
	Special information (Not applicable)	B-4 B-2
	How to locate repair part	B-5 B-2
	Federal supply code for manufacturer (FSCM)	B-6 B-2
II.	Repair parts for DS, GS, and depot maintenance	B-4
III.	Special tools, test, and support equipment	B-196
IV.	Index-federal stock number and reference number cross-reference to figure and item number	B-197
V.	Index-reference designation cross-reference to page number	B-259
INDEX	INDEX 1

LIST OF ILLUSTRATIONS

Figure No.	Title	Page
2-1	Radio Set AN/PRC-47, Overall Block Diagram	2-2
2-2	Receiver-Transmitter Circuits, Block Diagram.....	2-4
2-3	Frequency Control Circuits, Block Diagram.....	2-6
2-4	Power Supply Circuits, Block Diagram	2-8
2-5	Compressor/Amplifier Circuits, Schematic Diagram	2-14
2-6	Output Amplifier, CW Oscillator, and VOX Circuits, Schematic Diagram	2-16
2-7	Receiver Amplifier, AGC Circuit, and Sidetone Gate, Schematic Diagram.....	2-18
2-8	Balanced Modulator, ALC Amplifier Circuit, Schematic Diagram	2-19
2-9	IF. Amplifier Circuit, Schematic Diagram	2-20
2-10	Last If. Amplifier and Product Detector Circuit, Schematic Diagram	2-21
2-11	Isolation Amplifier Circuits, Schematic Diagram	2-22
2-12	Receive Mixer/Transmit Mixer Circuits, Schematic Diagram	2-24
2-13	Hf Oscillator and Varicap Control Circuits, Schematic Diagram	2-26
2-14	5- to 14-MHz Amplifier/Limiter Circuits, Schematic Diagram	2-27
2-15	Discriminator Circuit Waveforms	2-30
3-1	Preliminary Troubleshooting Diagram	3-4
3-2	Receiver Tests, Troubleshooting Test Setup	3-5
3-3	Transmitter Tests, Troubleshooting Test Setup.....	3-6
3-4	Radio Receiver-Transmitter RT-671/PRC-47 (A8), Top View, Location of Assemblies and Test Points	3-7
3-5	Radio Receiver-Transmitter RT-671/PRC-47 (A8), Bottom View, Location of Assemblies and Test Points	3-8
3-6	Audio Frequency Amplifier AM-3506/PRC-47 (A8A1), Top View, Cover Removed, Location of Subassemblies and Test Points	3-9
3-7	Amplifier-Modulator AM-3507/PRC-47 (A8A2), Side View, Cover Removed, Location of Subassemblies E1 and E2, and Test Points	3-10
3-8	Amplifier-Modulator AM-3507/PRC-47 (A8A2), Side View, Cover Removed, Location of Subassemblies E3, E4, and E5, and Test Points	3-10
3-9	Signal Data Translator CV-1377A/PRC-47 (A8A3), Top View, Location of Subassemblies and Test Points	3-11
3-10	Signal Data Translator CV-1377A/PRC-47 (A8A3), Bottom View, Location of Subassemblies	3-12
3-11	Power Supply PP-3518/PRC-47 (A8A5), Top View, Cover Removed, Location of Subassemblies and Test Points	3-13
3-12	Radio Frequency Oscillator O-1032/PRC-47 (A8A6), Side View, Cover Removed, Location of Subassemblies E1 and E2, and Test Points	3-14
3-13	Radio Frequency Oscillator O-1032/PRC-47 (A8A6), Side View, Cover Removed, Location of Chassis Subassembly and Test Points	3-15
3-14	Oscillator Control C-4311/PRC-47 (A8A7), Top View, Cover Removed, Location of Subassemblies and Test Points	3-16
3-15	Oscillator Control C-4311/PRC-47 (A8A7), Bottom View, Location of Subassemblies	3-17
3-16	Audio Frequency Amplifier AM-3506/PRC-47 (A8A1), Cover Removed, Chassis Subassembly	3-18
3-17	Audio Frequency Amplifier AM-3506/PRC-47 (A8A1), Cover Removed, Subassembly E1	3-19
3-18	Audio Frequency Amplifier AM-3506/PRC-47 (A8A1), Cover Removed, Subassembly E2	3-20
3-19	Audio Frequency Amplifier AM-3506/PRC-47 (A8A1), Cover Removed, Subassembly E3.....	3-21
3-20	Amplifier-Modulator AM-3507/PRC-47 (A8A2), Cover Removed, Subassemblies E1 and E2.....	3-22

LIST OF ILLUSTRATIONS (cont)

Figure No.	Title	Page
3-21	Amplifier-Modulator AM-3507/PRC-47 (A8A2), Cover Removed, Subassemblies E3, E4 and E5	3-23
3-22	Signal Data Translator CV-1377A/PRC-47 (A8A3), Card Assembly TB1	3-24
3-23	Signal Data Translator CV-1377A/PRC-47 (A8A3), Card Assembly TB2	3-24
3-24	Signal Data Translator CV-1377A/PRC-47 (A8A3), Switch Assemblies S1, S2, and S3, Top View, Card Assemblies E1 and E3	3-25
3-25	Signal Data Translator CV-1377A/PRC-47 (A8A3), Switch Assemblies S1, S2, and S3, Bottom View, Card Assemblies E2 and E4	3-25
3-26	Signal Data Translator CV-1377A/PRC-47 (A8A3), Switch Assembly S1, Rear View	3-26
3-27	Signal Data Translator CV-1377A/PRC-47 (A8A3), Switch Assembly S2, Rear View	3-26
3-28	Signal Data Translator CV-1377A/PRC-47 (A8A3), Switch Assembly S3, Rear View	3-27
3-29	Signal Data Translator CV-1377A/PRC-47 (ASA3), Switch Assembly S4, Rear View	3-27
3-30	Signal Data Translator CV-1377A/PRC-47 (A8A3), Switch Assembly S5, Rear View	3-28
3-31	Signal Data Translator CV-1377A/PRC-47 (A8A3), VFO Coil Subassembly, Top View.....	3-28
3-32	Signal Data Translator CV-1377A/PRC-47 (A8A3), VFO Coil Subassembly, Bottom View	3-29
3-33	Signal Data Translator CV-1377A/PRC-47 (A8A3), Switch Assembly S6, VFO Circuit	3-30
3-34	Signal Data Translator CV-1377A/PRC-47 (A8A3), Switch Assembly S7, Front View.....	3-31
3-35	Signal Data Translator CV-1377A/PRC-47 (A8A3), Switch Assembly S8, Rear View	3-31
3-36	Signal Data Translator CV-1377A/PRC-47 (A8A3), Switch Assembly S9, Rear View (Rotor at Index Position no.1.)	3-32
3-37	Signal Data Translator CV-1377A/PRC-47 (A8A3), Card Assembly E46	3-33
3-38	Signal Data Translator CV-1377A/PRC-47 (A8A3), Card Assembly E47	3-34
3-39	Signal Data Translator CV-1377A/PRC-47 (A8A3), Card Assembly E48	3-35
3-40	Signal Data Translator CV-1377A/PRC-47 (A8A3), Driver Tube (V3) Compartment, Bottom View	3-36
3-41	Signal Data Translator CV-1377A/PRC-47 (A8A3), Bottom View	3-37
3-42	Signal Data Translator CV-1377A/PRC-47 (A8A3), Typical Switch Card (S1 through S8) Showing Rotor at Index Position no.1	3-38
3-43	Signal Data Translator CV-1377A/PRC-47 (A8A3), Rear View, Frequency Range Switch Shaft Retaining Ring	3-38
3-44	Signal Data Translator CV-1377A/PRC-47 (A8A3), Front View, Coupler Position at 2,000 kHz Dial Setting	3-39
3-45	Power Supply PP-3518/PRC-47 (A8A5), Bottom View, Chassis.....	3-39
3-46	Power Supply PP-3518/PRC-47 (A8A5), Subassembly No. 1, Front View	3-40
3-47	Power Supply PP-3518/PRC-47 (A8A5), Subassembly No. 1, Rear View.....	3-40
3-48	Power Supply PP-3518/PRC-47 (A8A5), Subassembly No. 2	3-41
3-49	Power Supply PP-3518/PRC-47 (A8A5), Subassembly No. 3	3-41
3-50	Power Supply PP-3518/PRC-47 (A8A5), Upper Chassis Assembly	3-42
3-51	Power Supply PP-3518/PRC-47 (A8A5), Voltage Regulator Assembly TB1.....	3-43
3-52	Radio Frequency Oscillator 0-1032/PRC-47 (A8A6), Side View, Cover Removed, Card Assemblies E1 and E2	3-44
3-53	Radio Frequency Oscillator 0-1032/PRC-47 (A8A6), Side View, Cover Removed, Chassis Assembly	3-45

LIST OF ILLUSTRATIONS (cont)

Figure No.	Title	Page
3-54	Oscillator Control C-4311/PRC-47 (A8A7), Card Assembly E1	3-46
3-55	Oscillator Control C-4311/PRC-47 (A8A7), Card Assembly E2.	3-47
3-56	Oscillator Control C-4311/PRC-47 (A8A7), Card Assembly TBI	3-48
3-57	Oscillator Control C-4311/PRC-47 (A8A7), Card Assembly E4	3-49
3-58	Oscillator Control C-4311/PRC-47 (A8A7), Card Assembly E5	3-50
3-59	Oscillator Control C-4311/PRC-47 (A8A7), Card Assembly E6	3-51
3-60	Oscillator Control C-4311/PRC-47 (A8A7), Card Assemblies E7 and E8, Front View	3-52
3-61	Oscillator Control C-4311/PRC-47 (A8A7), Line Filter Assembly at Con- nector P1, Cover Removed	3-52
3-62	Oscillator Control C-4311/PRC-47 (A8A7), Switch Card S5 With Rotor Shown in Index Position no.1.....	3-53
3-63	Oscillator Control C-4311/PRC-47 (A8A7), Front View, Coupler Position at 2000 kHz Dial Setting	3-53
3-64	Power Amplifier Compartment (A8A4A1) Top-View, Cover Removed.....	3-54
3-65	Power Amplifier Compartment (A8A4A1) Bottom View, Cover Removed	3-55
3-66	Power Amplifier Compartment (A8A4A1) Power Amplifier Subassembly Parts Location	3-56
3-67	Radio Receiver-Transmitter RT-671/PRC-47 (A8), Bottom View, Cover Removed	3-57
3-68	Audio Frequency Amplifier AM-3506/PRC-47 (A8A1), Subassembly E1, Voltage and Resistance Diagram	3-58
3-69	Audio Frequency Amplifier AM-3506/PRC-47 (A8A1), Subassembly E2, Voltage and Resistance Diagram.....	3-59
3-70	Audio Frequency Amplifier AM-3506/PRC-47 (A8A1), Subassembly E3, Voltage and Resistance Diagram.....	3-60
3-71	Audio Frequency Amplifier AM-3506/PRC-47 (A8A1), Chassis Assembly, Voltage and Resistance Diagram.....	3-61
3-72	Amplifier-Modulator AM-3507/PRC-47 (A8A2), Subassemblies E1 and E2, Voltage and Resistance Diagram.....	3-62
3-73	Amplifier-Modulator AM-3507/PRC-47 (A8A2), Subassembly E3, Voltage and Resistance Diagram	3-63
3-74	Amplifier-Modulator AM-3507/PRC-47 (A8A2), Subassembly E4, Voltage and Resistance Diagram	3-64
3-75	Amplifier-Modulator AM-3507/PRC-47 (A8A2), Subassembly E5, Voltage and Resistance Diagram	3-65
3-76	Signal Data Translator CV-1377A/PRC-47 (A8A3), Driver Tube (V3) Compartment, Voltage and Resistance Diagram.....	3-66
3-77	Power Supply PP-3518/PRC-47 (A8A5), Voltage Regulator Assembly TB1, Voltage and Resistance Diagram.....	3-66
3-78	Radio Frequency Oscillator 0-1032/PRC-47 (A8A6), Subassembly E1, Voltage and Resistance Diagram.....	3-67
3-79	Radio Frequency Oscillator 0-1032/PRC-47 (A8A6), Subassembly E2, Voltage and Resistance Diagram.....	3-68
3-80	Radio Frequency Oscillator 0-1032/PRC-47 (A8A6), Chassis Assembly, Voltage and Resistance Diagram.....	3-69
3-81	Electrical Equipment Chassis CH-474/PRC-47 (A8), Power Oscillator Assembly, Voltage and Resistance Diagram.....	3-70
3-82	Electrical Equipment Chassis CH-474/PRC-47, PA Filter Box FL2 (A8A4) Voltage and Resistance Diagram.....	3-71
3-83	Oscillator Control C-4311/PRC-47 tA8A7), Top View, Waveform Diagram	3-72
3-84	Cable Assembly Set AN/PRA-4, Equipment Supplied	3-90

LIST OF ILLUSTRATIONS (cont)

Figure No.	Title	Page
3-85	Radio Receiver-Transmitter RT-671/PRC-47 (A8) Top View, Location of Modules and Stiffeners	3-91
3-86	Radio Receiver-Transmitter RT-671/PRC-47 (A8), Bottom View, Location of Module Retaining Screws	3-92
3-87	Radio Receiver-Transmitter RT-671/PRC-47 (A8), Front Panel View, Location of Access Openings and Panel Components	3-93
3-88	Frequency Selector Control, Switch Coupler Alignment Diagram	3-94
3-89	Radio Receiver-Transmitter RT-671/PRC-47, Power Amplifier Compartment (A8A4A1) Load-Tune Coil Assembly, Exploded View	3-94
3-90	Radio Receiver-Transmitter RT-671/PRC-47, Frequency Selector Mechanism (A8A4A1) Exploded View	3-94
3-91	Radio Receiver-Transmitter RT-671/PRC-47, Power Amplifier Compartment (A8A4A1) Plate Capacitor Switch, Exploded View	3-94
3-92	Radio Receiver-Transmitter RT-671/PRC-47, Power Amplifier Compartment (A8A4A1) XMTR PWR Switch (S103), Exploded View	3-94
3-93	Radio Receiver-Transmitter RT-671/PRC-47, Power Amplifier Compartment (A8A4A1) XMTR PWR Switch (S103), Connection Diagram	3-95
3-94	Audio Frequency Amplifier AM-3506/PRC-47 (A8A1), Top View, Location of Tests Points and Adjustments	3-117
3-95	Amplifier-Modulator AM-3507/PRC-47 (A8A2), Top View, Location of Test Points and Adjustments	3-118
3-96	Signal Data Translator CV-1377A/PRC-47 (A8A3), Top View, Location of Test Points and Adjustments	3-119
3-97	Signal Data Translator CV-1377A/PRC-47 (A8A3), Rear View, Location of Adjustments	3-120
3-98	Signal Data Translator CV-1377A/PRC-47 (A8A3), Right Side View, Location, Location of Adjustment C344	3-120
3-99	Radio Frequency Oscillator 0-1032/PRC-47 (A8A6), Top View, Location of Test Points and Adjustments	3-120
3-100	Oscillator Control C-4311/PRC-47 (A8A7), Top View, Location of Test Points and Adjustments	3-121
3-101	Oscillator Control C-4311/PRC-47 (A8A7), Bottom View, Location of Adjustments	3-122
3-102	Oscillator Control C-4311/PRC-47 (A8A7), Rear View, Location of Capacitor C15	3-123
3-103	Oscillator Control C-4311/PRC-47 (A8A7), Right Side, Location of Adjustments	3-123
3-104	Oscillator Control C-4311/PRC-47 (A8A7), Left Side, Location of Adjustments	3-123
3-105	Radio Receiver-Transmitter RT-671/PRC-47 (A8), Bottom View, Location of Test Points and Adjustments	3-124
3-106	Receiver Audio Output Adjustment, Test Equipment Setup	3-125
3-107	Receiver AGC Circuit Adjustment, Test Equipment Setup	3-126
3-108	Transmitter Sidetone Adjustment, Test Equipment Setup	3-127
3-109	Microphone Amplifier and VOX Gain Adjustments, Test Equipment Setup	3-127
3-110	Power Amplifier Grid Drive Adjustment, Test Equipment Setup	3-129
3-111	Temperature Compensated Oscillator Frequency Adjustment, Test Equipment Setup	3-130
3-112	Balanced Modulator Adjustments, Test Equipment Setup	3-131
4-1	Receiver Sensitivity, AVC, Selectivity, IF. Rejection, Image Rejection and Volume Control Tests, Equipment Setup	4-3
4-2	Receiver Audio Output Distortion Test, Equipment Setup	4-8
4-3	Receiver Power Input Requirements, Equipment Setup	4-9

Figure No.	Title	Page
4-4	Transmitter Power Output and Output Meter Sensitivity Tests, Equipment Setup	4-10
4-5	Transmitter Frequency Stability Tests, Equipment Setup	4-14
4-6	Transmitter Power Input Test, Equipment Setup	4-16
4-7	Transmitter CW Operation and Sidetone Test, Equipment Setup	4-17
5-1	Transmit Mixer Balance and Transmit Gain Control Adjustments, Equipment Setup	5-1
5-2	Transmitter Hum Balance Adjustment and Modulation Fidelity Tests, Equipment Setup	5-3
5-3	Transmitter Spurious Output Adjustments, Equipment Setup	5-5
6-1	Plug Gage, Slug Adjustment	6-2
6-2	Gage Overtravel, 0.041-inch	6-2
6-3	Output Attenuator, 50:1	6-2
6-4	Test Fixture for AM-3506/PRC-47, Suggested Layout	6-3
6-5	Test Fixture for AM-3507/PRC-47, Suggested Layout	6-4
6-6	Test Fixture for CV-1377A/PRC-47, Suggested Layout	6-5
6-7	Indexing Fixture for CV-1377A/PRC-47, Suggested Layout	6-6
6-8	Test Fixture for PP-3518/PRC-47, Suggested Layout	6-6
6-9	Test Fixture for 0-1032/PRC-47, Suggested Layout	6-7
6-10	Test Fixture for C-4311/PRC-47, Suggested Layout	6-8
6-11	Audio Frequency Amplifier AM-3506/PRC-47 (A8A1) Performance Tests, Initial Test Equipment Connections	6-14
6-12	Amplifier-Modulator AM-3507/PRC-47 (A8A2), Performance Tests, Initial Test Equipment Connections	6-16
6-13	Signal Data Translator CV-1377A/PRC-47 (A8A3), Performance Tests, Initial Test Equipment Connections	6-19
6-14	Power Supply PP-3518/PRC-47 (A8A5), Performance Tests, Initial Test Equipment Connections	6-25
6-15	Radio Frequency Oscillator 0-1032/PRC-47 (A8A6) Performance Tests, Initial Test Equipment Connections	6-28
6-16	Oscillator Control C-4311/PRC-47 (A8A7), Performance Tests, Initial Test Equipment Connections	6-31
6-17	Test Fixture for Audio Frequency Amplifier AM-3506/PRC-47, Parts Location	6-39
6-18	Test Fixture for Audio Frequency Amplifier AM-3506/PRC-47, Chassis Parts and Connector Location	6-40
6-19	Test Fixture for Amplifier-Modulator AM-3507/PRC-47, Parts Location.....	6-42
6-20	Test Fixture for Amplifier-Modulator AM-3507/PRC-47, Chassis Parts and Subassembly A1 Placement	6-43
6-21	Test Fixture for Signal Data Translator CV-1377A/PRC-47, Front View, Parts Location	6-46
6-22	Test Fixture for Signal Data Translator CV-1377A/PRC-47, Parts Location	6-47
6-23	Test Fixture for Signal Data Translator CV-1377A/PRC-47, Parts Location	6-48
6-24	Test Fixture for Power Supply PP-3518/PRC-47, Parts Location	6-51
6-25	Test Fixture for Power Supply PP-3518/PRC-47, Internal Parts Location.....	6-52
6-26	Test Fixture for Radio Frequency Oscillator 0-1032/PRC-47, Parts Location	6-55
6-27	Test Fixture for Oscillator Control C-4311/PRC-47, Parts Location	6-57
7-1	Color code marking for military standard resistors, inductors, and capacitors	(Foldout illustrations are Located in back of manual)

LIST OF ILLUSTRATIONS (cont)

Figure No.	Title	Page
7-2	Receive Signal Path, Block Diagram.....	7-2
7-3	Transmit Signal Path, Block Diagram	(Located in back of manual.)
7-4	Frequency Control Circuits, Block Diagram.....	"
7-5	Power Supply Circuits, DC Primary Power Input, Block Diagram	"
7-6	Power Supply Circuits, AC Primary Power Input, Block Diagram.....	"
7-7	Mechanical Schematic, Frequency Control Mechanism	"
7-8	Electrical Equipment Chassis CH-474/PRC-47 (A8A4), Schematic Diagram (2 sheets)	"
7-9	Audio Frequency Amplifier AM-3506/PRC-47 (A8A1), Schematic Diagram	
7-10	Amplifier-Modulator AM-3507/PRC-47 (A8A2), Schematic Diagram	"
7-11	Signal Data Translator CV-1377A/PRC-47 (A8A3), Schematic Diagram (2 sheets)	
7-12	Power Supply PP-3518/PRC-47 (A8A5), Schematic Diagram	"
7-13	Radio Frequency Oscillator 0-1032/PRC-47 (A8A6), Schematic Diagram.....	"
7-14	Oscillator Control C-4311/PRC-47 (A8A7), Schematic Diagram	"
7-15	Test Fixture for Audio Frequency Amplifier AM-3506/PRC-47, Schematic Diagram	7-4
7-16	Test Fixture for Amplifier-Modulator AM-3507/PRC-47, Schematic Diagram	7-5
7-17	Test Fixture for Signal Data Translator CV-1377A/PRC-47, Schematic	7-6
7-18	Test Fixture for Power Supply PP-3518/PRC-47, Schematic Diagram	7-7
7-19	Test Fixture for Radio Frequency Oscillator 0-1032/PRC-47, Schematic Diagram	7-8
7-20	Test Fixture for Oscillator Control C-4311/PRC-47, Schematic Diagram	7-8

**CHAPTER 1
INTRODUCTION**

1-1. Scope

a. This manual contains instructions for general support, direct support and depot maintenance of Radio Set AN/PRC-47. It includes instructions that are appropriate to the general support, direct support and depot maintenance routines for performance testing, troubleshooting, alignment, and repair of the equipment, the replacement of maintenance parts, and the repair of specific subassemblies. A list of tools, materials and test equipment that are required for maintenance is included. A detailed theory of operation for the equipment is included in chapter 2.

b. Operator and Organizational Maintenance Manual, Radio Set AN/PRC-47 TM 11-5820-509-12, including Repair Parts and Special Tools List and Maintenance Allocation Chart, contains additional information pertinent to this same equipment.

c. Only one model of Radio Set AN/PRC-47 is documented in this publication. An historical record of equipment revisions is shown in paragraph 1-4.

1-2. Indexes of Publications

a. *DA Pam 310-4.* Refer to the latest issue of DA PAM 310-4 to determine whether there are new editions, changes, or additional publications that pertain to this equipment.

b. *DA Pam 310-7* Refer to DA Pam 310-7 to determine whether there are modification work orders (MWO's) pertaining to this equipment.

NOTE

Other applicable forms and records are included in Operator and Organizational Maintenance Manual, Radio Set AN/PRC-47, TM 11-5820-509-12.

1-3. Reporting of Errors

The reporting of errors, omissions, and recommendations for improving this publication by the individual user is encouraged. These reports should be submitted on DA Form 2028 (Recommended Changes to Publications and Blank Forms) and forwarded direct to Commander, U.S. Army Electronics Command, ATTN: DRSEL-MA-Q Fort Monmouth, NJ 07703.

1-3.1 Reporting Equipment Improvement Recommendations (EIR)

EIR will be prepared using DA Form 2407 (Maintenance Request). Instructions for preparing EIR's are provided in TM 38-750, The Army Maintenance Management System. EIR's should be mailed directly to Commander, US Army Electronics Command, ATTN: DRSEL-MA-Q, Fort Monmouth, NJ 07703.

1-3.2. Administrative Storage

Administrative storage of equipment issued to and used by Army activities shall be in accordance with TM 740-90-1.

1-3.3 Destruction of Army Electronics Materiel

Destruction of Army electronics materiel to prevent enemy use shall be in accordance with TM 750-244-2.

1-4. Historical Revisions to Equipment

a. No External appearance or major operational differences exist between procurements of Radio Set AN/PRC-47.

b. The electrical subassemblies and plug-in modules of Radio Receiver-Transmitter RT-671/PRC-47 have been revised during the history of Radio Set AN/PRC-47 as indicated in the table below. Complete interchangeability of the electrical subassembly or module was retained.

Ref des	MCN effectivity	Description of change
AUDIO FREQUENCY AMPLIFIER AM-3506/PRC-47 (A8A1)		
A1C33	525	Changed to 47 uF, was 33 uF.
A1C39	525	Delete, was 22 uF.
A1CR14	525	Delete, was type 1N457.
A1Q11W / A1Q12X	525	Changed to matched pair, type 2N158A match Beta within 25% at I _c = 250 ma
A1R55	525	Changed to 18K, was 100K ohms.
A1R60	525	Changed to 16.2K 2as 7.5K ohms.
A1R69	525	Delete, was 18K ohms
A1R70	525	Delete, was 470K ohms.
A1R71	525	Delete, was 2,200 ohms.
A1R72	525	Changed to 1,200 was 2,700 ohms.

Ref des	MCN effectivity	Description of change
A1CR18	2366	Added CR18, type 1N457.
A1C8 / A1C12	No record	Changed to 100 uF, was 47 uF.
A1Q1	No record	Changed to type 2N404, was type 2N422.
A1C26	4300	Polarity on silk-screen was reversed.
A1R85	4300	Added R85, 10K ohms.

AMPLIFIER-MODULATOR AM-3507/PRC-47 (A8A2)

A2C37	203	Added C37, 0.47 uF.
A2CR9 / A2CR10	203	Delete, was type 1N66.
A2CR9	203	Added CR9, type IN916.
A2R27	203	Delete, was 120 ohms.
A2R27	203	Added R27, 100K ohms.
A2R33	203	Changed to 4,700, was 2,700 ohms.
A2R34	203	Changed to 100K, was 12K ohms.
A2C36	No record	Actual value selected for performance; nominal value 18 pF.
A2C16	422	Changed to 91 pF, was 68 pF.
A2R25	422	Changed to 2,700, was 2,200 ohms.
A2C12	525	Changed to 240 pF, was 0.05 uF.
A2C23	658	Changed to 1 uF, was 0.1 uF.
A2R17	805 and 211,305	R17: changed to 1,800, was 1K ohms.
A2RT1	410, 438, 453, 456, 468, 471, 472, 480, 481, 502, 517, 521, 523, 524.	RT1: added, 3K ohms thermal
A2C26	1166	Changed to 0.05 uF, was 0.1 uF.
A2R33	1654	Changed to 2,700, was 4,700 ohms.
A2R34	1654	Changed to 27K, was 100K ohms.
A2R35	1654	Changed to 47K, was 56K ohms.
A2R33	1646	Changed to 1.5K, was 2,700 (retrofit).
A2R34	1646	Changed to 10K, was 27K ohms (retrofit).
A2R35	1646	Changed to 68K, was 47K ohms (retrofit).
A2R41	1811	Changed to ½ -watt film, was ¼ -watt composition.
A2R45	2068	Changed to 680, was 1,200 ohms.
A2R14	2182	Actual value selected for performance; nominal value 3,900 ohms.
A2CR7 / A2CR8	2314	Changed to type IN198, was type 1N67A.
A2R29	2314	Changed to 5,600, was 18K ohms.
A2R31	2314	Changed to 10K, was 18K ohms.
A2C10	2750	Changed to 150 vdcw, was 100 vdcw.
A2Q2 A2Q3 /	No record	Changed preferred type to 2N274, with Sig C-2N274 as alternate.
A2Q4 / A2Q5	No record	Changed to 27K, was 10K ohms.
A2R34	Plan 4838	Changed style; delete fasteners on preferred type; retain for old type as alternate.
A2K1	Plan 4838	Deleted Sig CG2N274 as alternate type.
A2Q2 /A2Q31	No record	Delete Sig CG2N274 as alternate type.
A2Q4 / A2Q5	No record	(Changed to 1.5K, was, 1,800 ohms.

SIGNAL DATA. TRANSLATOR CV-1377A/PRC-47 (A8A3)

A3C165	183	Changed to 10 pF. was 20 pF
A3C167	183	Changed to 220 pF. was 75 pF.
A3C168	183	Actual value selected for performance; nominal value 150 pF.
A3C169	183	Changed to 75 pF, was 220 pF.
A3C170	183	Changed to 220 pF, was 68 pF.
A3C42	Plan 199	changed to 190 pF, was .-,30 pF.
A3C146	433	Delete, was 390 pF.
A3C148	433	Added C148, 390 pF.
A3CR3 / A3CR8	No record	CR3 was CR3B, CRLS was C,R3A, each changed to type 1N198, was ½ of FA2000.
A3Q11	500	Changed to type 2N708, was type 2N70:3.
A3CR1	506	Delete, was type 1N916.
A3R73/	506	Delete, each was 470K ohms.
A3R74 /		
A3R75 /		

Ref des	MCN effectivity	Description of change
A3R76		
A3C187	600	Changed to 27 pF, was 20 pF.
A3C42	Plan 737	Changed to 270 pF, was 190 pF.
A3C248 /	900	Changed each to 8-50 pF, was 5-30 pF.
A3C250/		
A3C252		
A3C249	900	Changed to 287 pF, was 300 pF.
A3C251	900	Changed to 165 pF, was 200 pF.
A3C253	900	Changed to 133 pF, was 120 pF.
A3C255	900	Changed to 91 pF, was 82 pF.
A3C257	900	Changed to 62 pF, was 68 pF.
A3C259	900	Changed to 39 pF, was 56 pF.

Change 2 1-3

Ref des	MCN effectivity	Description of change
OSCILLATOR CONTROL C-4311/PRC-47 (ASA7) (cont)		
A7CR16/A7CR17	5000	Added CR16, CR17, each type 1N754A.
A7R46/A7R65	5000	Changed to 4,700, each was 12K ohms.
A7C200/A7C201	5416	Added C200, C201, each 15 pF.
A7R42/A7R62	5416	Changed to 47, each was 348 ohms.
A7R48/A7R67	5416	Changed to 10K, each was 5,110 ohms.
A7C6	No record	Delete, was 150 pF.
A7C9	No record	Changed to 0.1 uF paper, was ceramic.
A7C200/A7C201	No record	Delete, each was 15 pF.
A7R7	No record	Changed to 1,800, was 2,700 ohms.
A7R42/A7R62	No record	Changed to 348, each was 47 ohms.
ELECTRICAL EQUIPMENT CHASSIS CH-474/PRC-47 (A8A4)		
A4R1 to R4	102, 116 to 121, 124 to 134, 136 to 139 and 141.	Changed R1 and R2 to 6.8, was 12 ohms. Changed R3 and R4 to 470, was 800 ohms.
A4C26/C27	167	Added C26, C27, each 2.5 uF.
A4L4 to L6	167	Added L4, 14 Turns; L5, L6, 10 mH.
A4K6	214	Added K6, dpdt.
A4R126	214	Added R126, 19.6K ohms.
A4R127	214	Added R127, 1,210 ohms.
A4C28	352	Added C28, 0.02 uF..
A4C121	400	Changed to 20 pF, was 40 pF.
A4R117	600	Changed to 5K, was 1 megohm.
A4R118	600	Changed to 1K, was 39K ohms.
A4C152	710	Deleted, was 82 pF.
A4R129	713	Added R129, 470 ohms.
A4C28	Plan 1464	Added C28, 0.02 uF.
A4C228	2028	Deleted, was 0.01 uF.
A4F4	No record	Added F4, 1/500A.
A4F5	No record	Added F5, 1/10A.
A4Q1/Q2	No record	Each was type 2N2287, added alternate type 2N1166.
A4R128	No record	Added R128, 100K ohms.

**CHAPTER 2
FUNCTION OF EQUIPMENT**

2-1. System Applications

a. Radio Set AN/PRC-47 provides singlesideband voice (usb only), continuous wave (cw) telegraphy, and frequency shift keying (fsk) teletypewriter modes of ground radio communication in the high frequency (hf) spectrum from 2.000 to 11.999-MHz and is operationally compatible with the AN/TRC-75 and similar radio equipment. The radio set is a two-man team, pack-transportable, transmitter-receiver that is contained in transportable carrying cases. It includes an antenna system and all necessary accessory items for telegraph and telephone operation but does not include an fsk input/output device or teletypewriter machines. The transmitter provides 100 watts peak-enveloppower (pep) output when operating singlesideband, and when equipped with a suitable blower/converter, such as CV-2455/PRC-47, will provide 100 watts average power in teletypewriter service. The receiver provides a minimum power output of 50 milliwatts from an input signal of 2.0 microvolts for a 10-dB signal-plus-noise to noise ratio.

b. Radio Set AN/PRC-47 normally is implemented for push-to-talk (ptt) operation. A field modification can be easily accomplished in Electrical Equipment Chassis Ch-474/PRC-47 that converts the equipment for voice-operated transmit (vox) operation. This vox option is implemented by strapping pin 11 (push-to-talk) to pin 20 (vox) at connector J1 (Power Supply PP3318/PRC-47, module A5). The discussion below assumes that this option is implemented: In the absence of this modification, only push-to-talk (ptt) operation is possible and reference to the vox mode and to the circuit description for the vox amplifier and relay driver stages may be ignored.

2-2. Block Diagram Explanations

a. This section presents the general theory of operation for Radio Set AN/PRC-47 on a block diagram level. The general theory first describes the relationships between the six major functional areas of the equipment. These areas are: the audio input devices, the cw telegraph key, the audio output devices, the external power sources, the antenna system, and the Radio Receive Transmitter RT-671/PRC-47 (A8).

Except for RT-671/PRC-47, the other functional equipments are considered accessory items and these are each discussed in the several optional configurations as they effect the general theory. Since the radio set is a compact, modularized, portable transceiver, many of the circuits and devices used for transmitting are also used for receiving. These circuits are described as part of the applicable signal function and appear in the appropriate block diagram for that function.

b. The discussion relating to the theory of operation and the maintenance requirements for the AN/PRC-47 include reference designators that describe the module, the circuit stage, and the component part of the circuit being discussed in the equipment. These reference designators are assigned in accordance with MIL-STD-16B, and an understanding of this identification method will assist in locating individual components within the overall equipment. For example, reference designator A1C1 refers to capacitor number one in modular assembly A8A1. Radio Receiver-Transmitter RT-671/PRC-47 (A8) contains the following nomenclatured subassemblies and associated components.

REF DES	OFFICIAL NOMENCLATURE
A1	Audio Frequency Amplifier AM-3506/PRC-47
A2	Amplifier-Modulator AM-3507/PRC-47
A3	Signal Data Translator CV-1377A/PRC-47
A4	Electrical Equipment Chassis CH-474/PRC-47
A5	Power Supply PP-3518/PRC-47
A6	Radio Frequency Oscillator O-1032/PRC-47
A7	Oscillator Control C-4311/PRC-47
A8	Panel Cover CW-647/PRC-47

2-3. Overall Block Diagram

a. Figure 2-1 is an overall block diagram for Radio Set AN/PRC-47 that shows the relationship between the several modules of Radio Receiver-Transmitter RT-671/PRC-47 and the external accessory items. The RT-671/PRC-47 contains the electronics that provide singlesideband voice, continuous wave (cw) telegraphy,

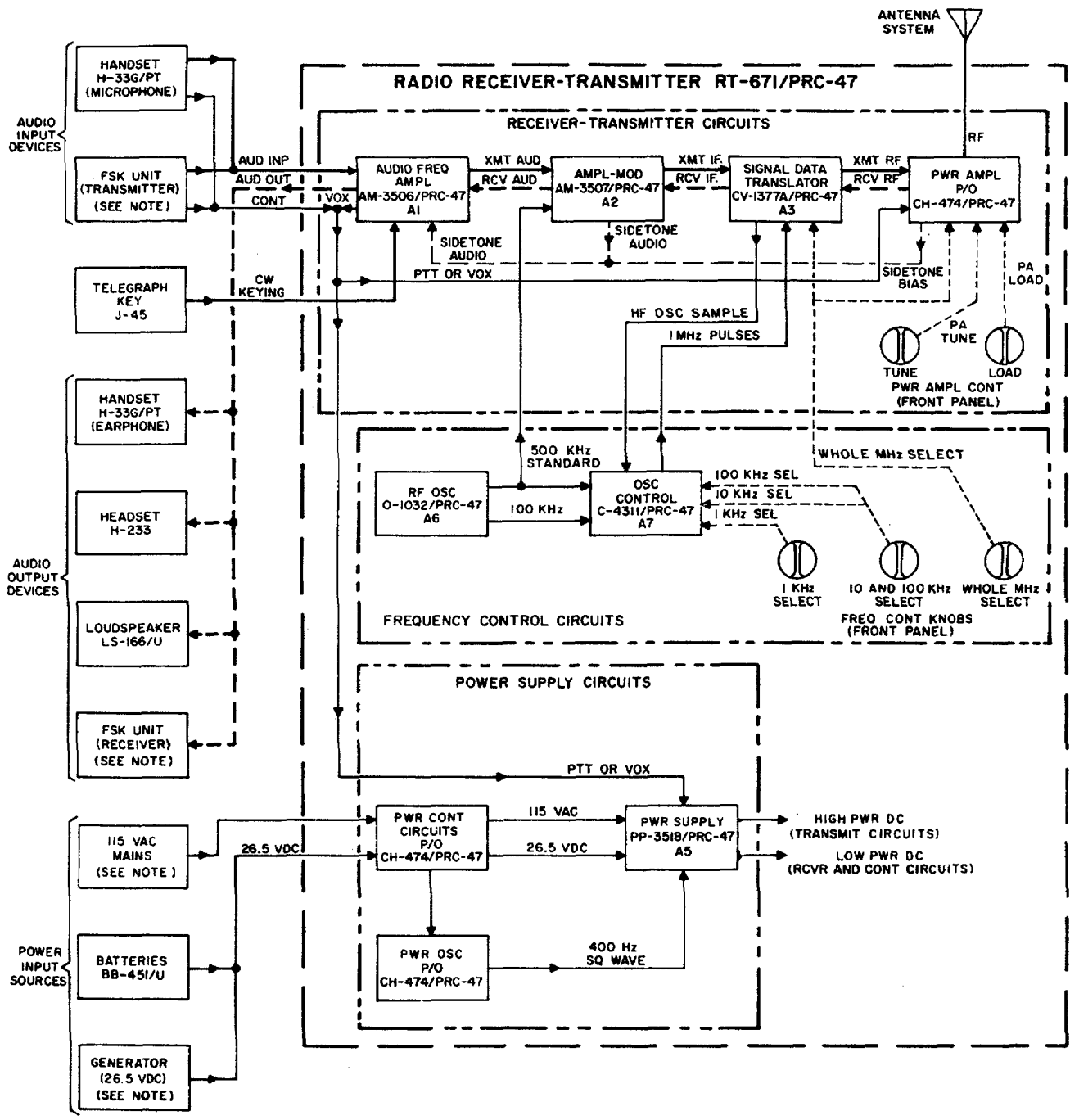

NOTE:
EQUIPMENT NOT PART OF AN/PRC-47.

TM5820-509-35-1

Figure 2-1. Radio set AN/PRC-47, Overall Block Diagram.

or frequency shift keying (fsk) teletypewriter communications when an appropriate input/output device is connected. The operating frequency is determined by the adjustment of front panel frequency controls that permit operation within the range from 2.0 to 11.999-MHz. During the transmit function, the audio signal is applied to the input of Audio Frequency

Amplifier AM-3506/PRC-47 (A1) by the microphone of Handset H-33G/PT or by the external fsk unit (for example, Converter Oscillator CV-786/TRC-75). Internal limiter stages and automatic load control circuits in the transmitter compensate for input level variations from these audio input devices. When cw

operation is desired, Telegraph Key J-45 is connected to the AUDIO connector of RT-671/PRC-47. This device keys an oscillator in the receiver-transmitter circuits that produces an audio tone. This modulating signal, or the voice input signal from the handset microphone or the fsk unit, is amplified in the AM-3506/PRC-47 (A1), and is mixed in the AM-3507/PRC-47 (A2) with a 500-kHz standard signal to produce a double-sideband, suppressed carrier signal. With the undesired sideband and the carrier signals greatly attenuated, the remaining singlesideband signal is heterodyned to the desired hf radio channel in the CV-1377A/PRC-47 (A3) by mixing it with the hf oscillator signal from the frequency control circuits. This rf signal is then amplified by the driver stage and the power amplifier and then applied to the antenna system. A portion of the transmitter audio is returned to the connected audio output device as a sidetone signal to permit monitoring during these transmit periods.

b. During receive periods the receiver transmitter circuits process the incoming signal using some of the identical circuits just mentioned in connection with the transmit function. This receive signal is heterodyned to an intermediate frequency near 500 kHz and then it is demodulated to recover the desired audio component. The audio signal is then applied to the connected audio output device. The receiver output is controlled by the VOLUME control on the front panel of RT-671/PRC-47. This control permits adjustment of the receiver output for a comfortable listening level with the earphone of Handset H-33G/PT, with Headset H-233, or with loudspeaker LS-166/U. It also permits adjustment of the input level to the external fsk unit, if connected.

c. The frequency control circuits provide two highly stable signals that are used in the receiver transmitter circuits to generate hf singlesideband transmit signals and to demodulate these signals to obtain audio output in the receive mode. The 500-kHz standard signal is fixed-tuned and applied to the balanced modulator circuit of the transmitter and to the product detector circuit of the receiver. The 2.5 to 12.499-MHz hf oscillator signal is tunable in 1-kHz steps to provide transmitter output in the hf range between 2.0-11.999-MHz.

d. The power supply circuits provide all operating voltages required by the AN/PRC-47.

These potentials are derived from either a 26.5 volt dc or a 115-volt, 400-Hz ac primary power source. If the

26.5-volt dc source is desired, Storage Battery BB-451/U or a suitable dc generator set may be used. The power supply circuits of the RT-671/PRC-47 provide high-power dc voltages for the transmitter circuits, and low-power potentials for the receiver circuits and for control purposes.

2-4. General Description

a. The transmit signal path through the receiver-transmitter circuits of the radio set is shown by the solid lines of figure 2-2. The transmit audio signal is applied to the input of the microphone amplifier where it is amplified and compressed before application to other circuits in the AN/PRC-47. When continuous wave (cw) telegraphy is required, the telegraph key is connected to an 800-Hz audio oscillator. The output of this circuit is a single audio tone that is present when the telegraph key is closed. This signal is amplified by circuits in the microphone amplifier. The amplified voice audio (or tone) from the microphone amplifier circuit is routed to the vox circuit, the audio output amplifier, and to the balanced modulator. The vox (voice-operated-transmit) circuit generates a control voltage that switches the radio set from the receive mode to the transmit mode when audio signals are present in the microphone amplifier output. The audio output amplifier receives a sidetone signal when the transmit mode is enabled. This sidetone is amplified and routed to the earphone (or other audio output device) and permits monitoring the transmitted signal. The transmit audio is mixed in the balanced modulator with a 500-kHz standard signal from the frequency control circuits. The out-put of the balanced modulator is a double-sideband signal with the amplitude of the 500-kHz standard signal greatly reduced. This intermediate (if.) frequency signal is amplified and then applied to a bandpass filter where the upper sideband and the carrier are further attenuated but the lower sideband is permitted to pass on the remaining if. amplifier stages. The amplified lower-sideband signal is applied to the transmit mixer where it is combine with a 2.5 to 12.499-MHz hf oscillator signal from the frequency control circuits. The difference frequency (2.0to 11.999-MHz) present in the output of the transmit mixer is amplified by the rf amplifier and driver stages and by the power amplifier and is applied to the antenna system through the t/r relay.

b. The receive signal path through the receiver-transmitter circuits of the AN/PRC-47 is shown by the dashed lines in figure 2-2. The

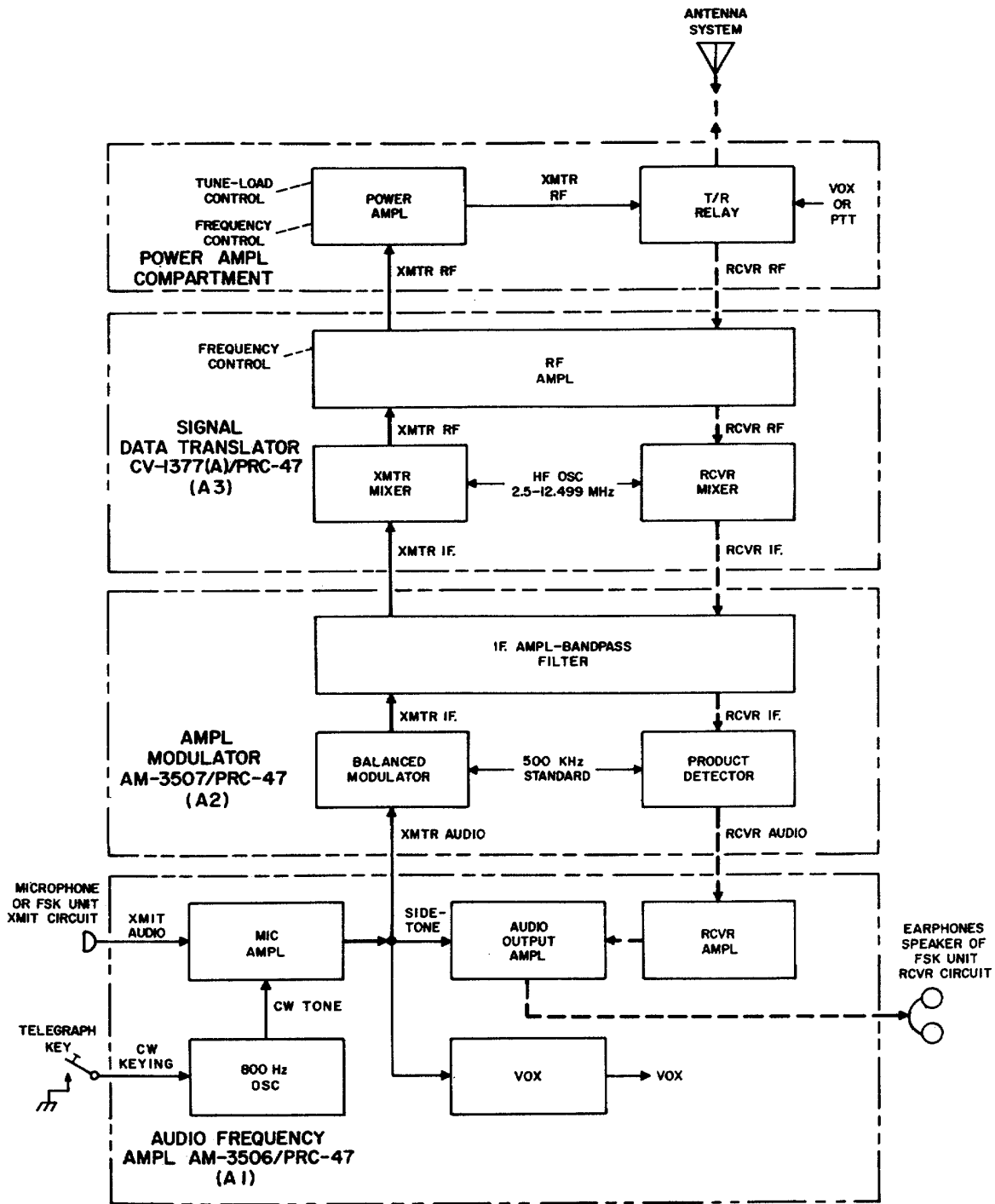

TM5820-509-35-2

Figure 2-2. Receiver-Transmitter Circuits, Block Diagram

receive rf from the antenna system passes through the t/r relay directly to the rf amplifier stages. Tuned circuits in these stages reject unwanted signals that may enter the antenna system, and select only the desired band of signals for amplification before routing them to the receiver mixer. In the receiver mixer, the rf signal is heterodyned with the 2.5 to 12.499-MHz hf oscillator signal to produce an intermediate frequency output near 500-kHz. The if. amplifier and bandpass filter circuits used for transmitting are also used in the receive mode. In these circuits the incoming signal is amplified while undesired adjacent-channel and image signals are attenuated before the if. signal is applied to the product detector. The output of the product detector is the demodulated single-sideband receive if. signal. This audio output is filtered and then amplified by the receiver amplifier and audio output amplifier circuits before being applied to the earphone or other connected audio output device.

c. The frequency control circuits of Radio Set AN/PRC-47 are shown in figure 2-3. The hf oscillator signal for both the transmit and receive functions is obtained from the variable frequency oscillator (vfo) of Signal Data Translator CV1377A/PRC-47 (A3). This

oscillator is coarse-tuned in ten 1-MHz stems by the whole megahertz control knob on the front panel of RT671/PRC-47. Fine tuning is accomplished by varying the vfo output inductor with the 10-kHz and the 100-kHz frequency control knobs, or by the application of a dc error voltage to the frequency determining circuits by the discriminator of Oscillator Control C-4311/PRC-47 (A7). This discriminator is part of a closed-loop frequency control system that compares the vfo output with crystal-controlled reference oscillator frequencies and then automatically adjusts the vfo output frequency to synchronize it with the crystal standard frequencies. The crystal oscillators are adjustable in four decades: whole megahertz step, 100-kHz steps, 10-kHz steps, and 1-kHz steps. The whole megahertz and 100kHz signals are derived from a common highly stabilized crystal-controlled source in Radio Frequency Oscillator 0-1032/PRC-47 (A6). This 3-MHz primary signal is first divided by six to obtain the 500-kHz standard signal used by the receiver-transmitter circuits and by the 1-MHz pulse generator in the CV-1377A/PRC-47 (A3). Then this 500-kHz output is further divided by five to obtain the 100-kHz signal used in the 100kHz pulse generator circuit of oscillator control

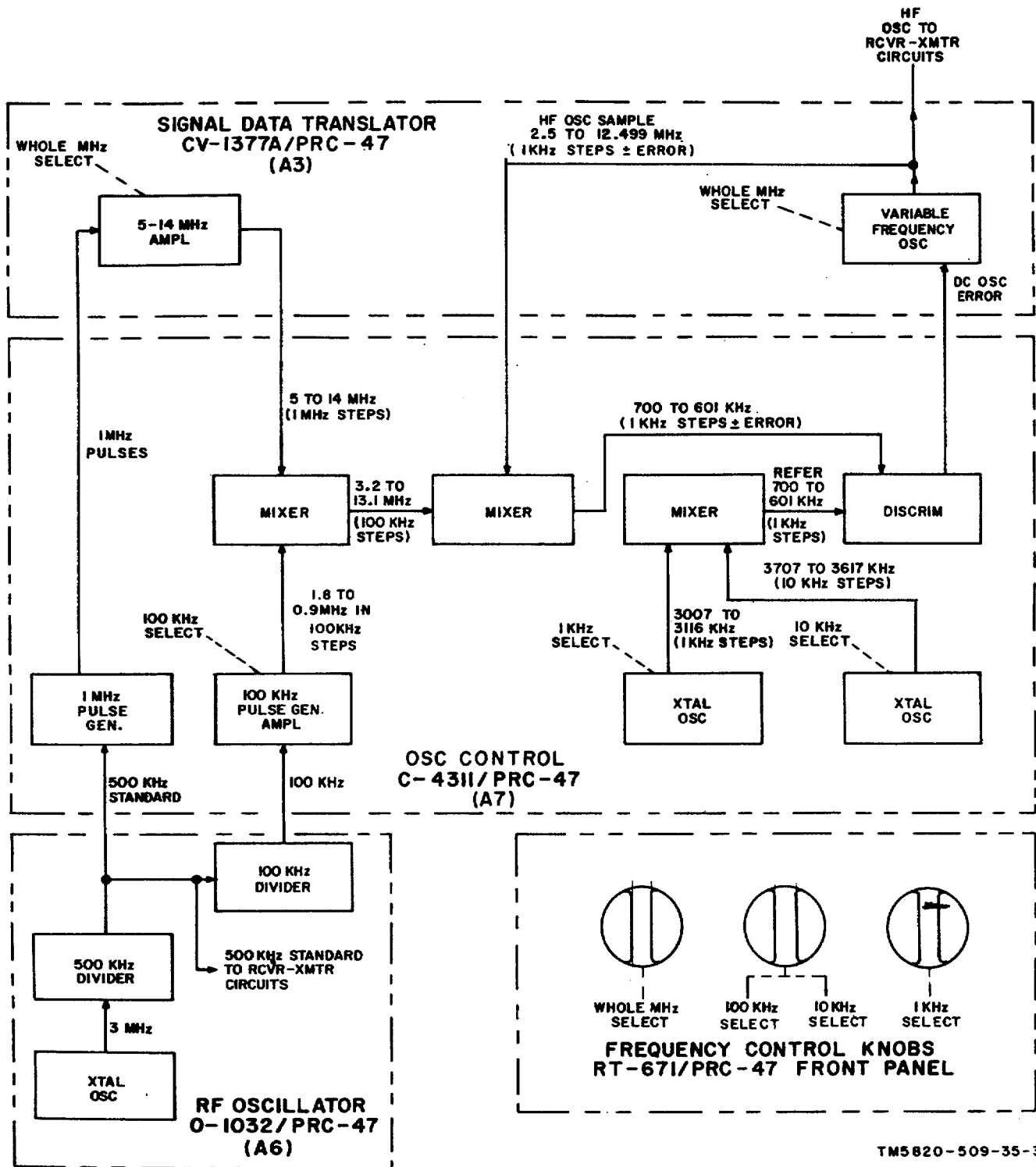

TM5820-509-35-3

Figure 2-3. Frequency Control circuits, Block Diagram

A7. The 1-MHz pulse generator of this module doubles the incoming 500-kHz standard signal and then converts the resulting signal into a 1-MHz pulse-train. These pulses are applied to the 5 to 14-MHz amplifier circuits of the CV1377A/PRC-47 (A3) where a ringer generates

a sine wave output at the 1-MHz frequency step that has been selected by the frequency control knobs on the front panel. The 100-kHz output of the divider in radio frequency oscillator (A6) is applied to the 100-kHz pulse

generator circuit of oscillator control (A7). This circuit generates a 100-kHz pulse-train and then converts it to a sine wave at any single 100-kHz frequency step between 1.8 and 0.9 MHz. The selected whole megahertz output of the 5 to 14-MHz amplifier in CV-1377A/PRC-47 (A3) is combined with the selected 100-kHz output of the 1.8 to 0.9-MHz circuits in a mixer whose output is the difference between these two input frequencies. The resulting reference signal has a range from 3.2 to 13.1 MHz in 100-kHz steps, and it is combined with the 2.5 to 12.499-MHz vfo signal in a second mixer circuit. The resulting 700 to 601-kHz signal represents the hf oscillator output with an accrued frequency error. Two crystal oscillators in C-4311/PRC-47 (A7) provide reference signals that are combined also in a mixer. These oscillators are adjusted by the gear-train associated with the 1-kHz and the 10-kHz frequency dials of the KILOCYCLES indicator on the front panel of RT-671/PRC-47. The output of this third mixer represents the desired channel selection in 1-kHz steps, and this frequency is combined in the discriminator circuit with the output of the second mixer to obtain an error voltage proportional to the vfo error signal. The output of the discriminator controls the vfo and returns it to the desired operating frequency.

d. The power supply circuits of the AN/PRC47 are shown in figure 2-4. These circuits obtain primary power from either the 115-volt, 400-Hz ac mains or from a 26.5 volt dc primary power source similar to Storage Battery BB-451/U. The appropriate circuit within the power supply is automatically selected when the power cable is attached to the front panel connector of the radio set. Operation of the POWER-LIGHTS switch on the front of RT-671/PRC-47 to the POWER ON position causes the appropriate power control relay to operate and connect the appropriate input circuit to the selected primary

power source. Interlocking is provided so that alternate source input circuits are disconnected. When the receive mode is selected, all necessary voltages for the radio set are provided by the low-voltage filter regulator circuit of Power Supply PP-3518/PRC47 (A5). This subassembly filters and regulates the 26.5-volt dc primary power when the dc mains are connected, but when the 115-volt, 400-Hz primary power source is attached, a portion of this voltage is rectified by the low-voltage circuits and then smoothed by the filter-regulator before application to the circuits in the modules of the equipment. When the transmit mode is enabled, high-voltage power supply circuits provide heater, bias, and plate power for the vacuum tubes and bias voltages for the transistorized circuits of the radio set. The high-voltage power supply circuits are enabled by operation of the push-to-talk (ptt) switch on the operator's handset, by placing the CW-FSK/VOICE switch on the front of RT-671/PRC-47 to CW-FSK, or by setting the OPR-TUNE switch on the front of RT-671/PRC-47 to TUNE. When the 115-volt ac primary power mains are connected, operation of the high-voltage transformer and rectifier-filter circuits is conventional. A multiple-secondary high-voltage transformer provides ac power to the several rectifier-filter circuits that distribute the required transmitter voltages. If the 26.5-volt dc primary power source is connected, however, a portion of this power is applied to a 400-Hz power oscillator on the main chassis of RT-671/PRC-47. This circuit performs the normal inverter function and generates a square-wave voltage whose output amplitude is approximately 26.5 volts at 400 Hz. The square-wave voltage from this power oscillator is applied to an appropriate primary winding on the high-voltage transformer and suitable output voltages are obtained from the connected rectifier-filter circuits.

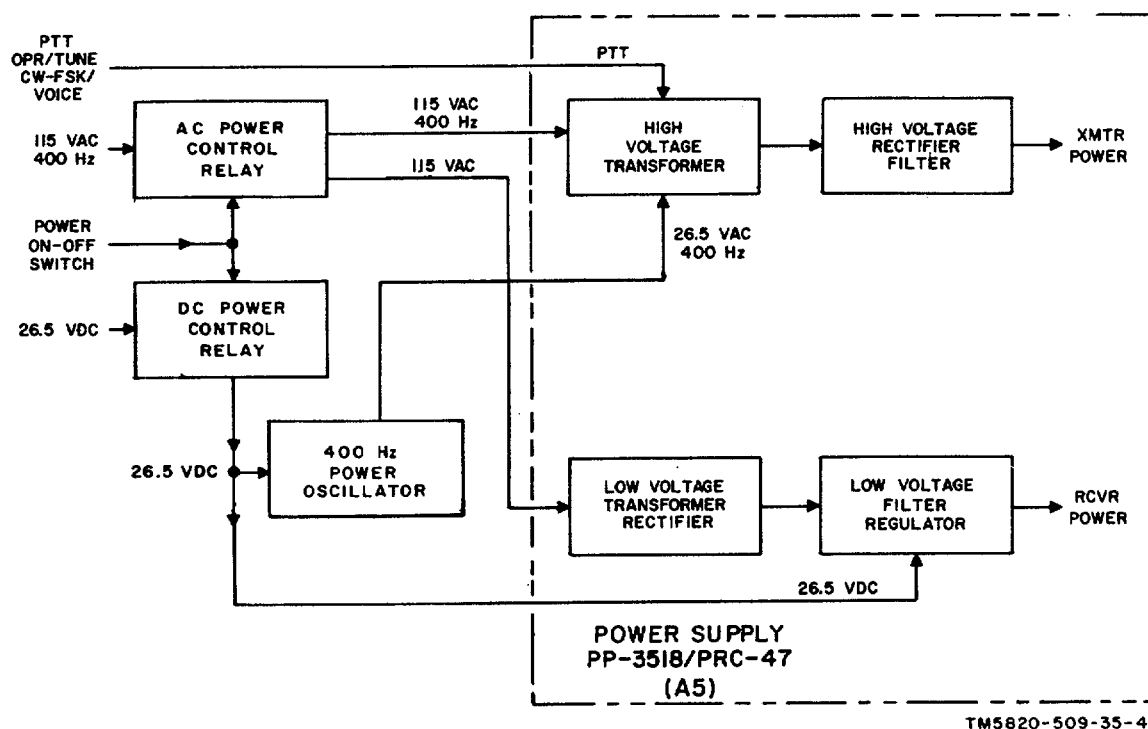

Figure 2-4. Power Supply Circuits, Block Diagram.

2-5. Receive Signal Path

(fig. 7-2)

a. In the receive mode, the 2.0 to 11.999-MHz rf signal from the antenna system is routed through the normally-closed contacts of t/r relay K101 in the power amplifier compartment to receiver antenna relay K5 on the Main chassis of the receiver-transmitter. Both of these relays are deenergized in the receive mode, but are energized by the voice-operated-transmit (vox) circuits during transmitter operation. The receive rf signals from the normally closed contacts of receiver antenna relay K5 pass through the tuned circuits of signal data translator A3 and are amplified by rf amplifiers V1 and V2. These stages are also used to amplify transmit rf signals when the transmit mode is selected, and are tuned to the operating frequency selected by the frequency control knobs on the front panel of RT671/PRC-47. The additional selectivity provided by these tuned circuits restricts the signals applied to the rf amplifier input to those that are on, or very near, the selected operating channel.

b. Relay A3K1 is deenergized during receiver operation and its contacts route the amplified rf signal from the second rf amplifier (V2) to follower Q10. (During transmit periods, A3K1 is energized and capacitor C187 is connected to the output of V2.) The hf oscillator signal from the frequency control circuits is isolated by follower 24 Q12 and is then mixed in

receiver mixer Q11 with the output of Q10. The difference between these two signals, approximately 500 kHz, is applied to follower Q9 and routed to the if. amplifier circuits of amplifier-modulator A2. After amplification by A2Q2, the if. signal is routed through bandpass filter FL1 where the if. carrier signal and the undesired sideband are greatly attenuated. Following additional amplification by if. amplifiers Q3 through Q5, this signal is demodulated by the product detector circuit.

c. The audio component of the if. signal is extracted by mixing the if. signal with a carrier injection signal (500-kHz standard) at the intermediate frequency. The output of the product detector is then passed through a low-pass filter to remove undesired frequencies caused by mixing and then amplified by driver stage Q10 and audio output amplifier Q11WQ12X in audio frequency amplifier A1. This amplified audio signal is applied to the corrected audio output device through front panel VOLUME control R11-R12. Once the average audio output level has been established by the setting of the VOLUME control, automatic gain control (agc) circuits in audio frequency amplifier A1 maintain the output level relatively constant despite fading signal conditions. The +agc voltage from agc amplifier Q9 is applied to if. amplifiers Q2 and Q3 while the -agc output of detector CR12-CR13 is applied to

the grid circuits of rf amplifiers V1 and V2 in signal data translator A3.

2-6. Transmit Signal Path (fig. 7-3)

a. In the transmit mode, the audio signal is obtained from the microphone of Handset H 33G/PT or from the transmit output circuits of an external fsk unit. This signal is connected to the transmit audio input of audio frequency amplifier A1 where it is amplified by microphone amplifier Q1 and Q3, clipped by limiters CR5-CR6, further amplified by output amplifier Q4, and applied to the audio input of the balanced modulator of amplifier-modulator A2. Part of the amplified audio output from Q4 is also applied to sidetone gate CR10. This gate is enabled during transmit periods by the bias from sidetone rectifier CR101 in the power amplifier compartment so that the sidetone audio from Q4 is routed through driver Q10, audio output amplifier Q1 1W-Q12X and VOLUME control R11-R12 to the connected audio output device. The sidetone audio is then available for monitoring purposes.

b. Another part of the output signal from Q4 is applied to vox detector CR7-CR8. When this signal level exceeds a minimum threshold value, vox relay K 1 transfers circuit functions in the RT-671/PRC-47 from the receive mode to the transmit mode. If the audio signal drops below this threshold level, or disappears completely for a predetermined period of time, these circuits will automatically return to the receive configuration. (Where the vox mode is not implemented, vox relay K1 cannot cause operation of the ptt relay (A5K1) in power supply module A5. This relay operates when the ptt switch on the operator's handset is pressed and energizes the high-voltage power supply circuits.) If continuous wave (cw) telegraphy is desired, the circuit functions described above apply except that Telegraph Key J-45 turns on, and shuts off, the audio tone generated by oscillator Q5. This tone replaces the voice audio at the input of microphone amplifier Q3, and is amplified by the remaining circuits of audio frequency amplifier A 1. In the cw mode, the CW-FSK/VOICE switch on the front panel of RT-671 /PRC-47 is placed in the CW-FSK position so that vox relay A1K1 and ptt relay A5K1 are both energized. The CW-FSK/VOICE switch must be returned to the VOICE position when it is desired to receive incoming telegraph or teletypewriter signals (i.e., break-in operation is not possible).

c. That part of the audio signal from Q4 that is applied to the balanced modulator of amplifier-modulator A2 is mixed with the 500-kHz stan-

dard signal from the frequency control circuits. The resulting output from the balanced modulator is a double-sideband, suppressed-carrier signal that is amplified by alc amplifier Q1 and if amplifier Q2 before being applied to bandpass filter FL1. Only the lower sideband remains after this signal is applied to FL1 and this single sideband is further amplified by Q3 through Q5 before being applied to signal data translator A3. If amplifiers Q3 through A5 and bandpass filter FL1 are shared with the receiver circuits of the receiver-transmitter, but during the transmit period the agc bias otherwise applied to Q2 and Q3 is removed so that the if. gain of this circuit will not vary as a function of modulation.

d. Transmit relay A2K1 in amplifier-modulator A2) is energized for transmit operation by closure of vox relay A1K1. The output of if. amplifier Q5 is routed through the closed contacts of A2K1 to the transmit mixer (CR3-CR8) in signal data translator A3. The 2.5- to 12.499-MHz hf oscillator signal from the frequency control circuits is applied to the transmit mixer through follower Q13. The difference-frequency obtained by heterodyning this signal with the 500-kHz if. output of Q5 is a 2.0 to 11.999-MHz single-sideband rf signal that is buffered by follower Q14 before being applied to amplifier Q15 and subsequently to rf amplifiers V1 and V2. The amplified hf output of V2 is further amplified by driver V3 and power amplifier V101. The output circuit of the power amplifier is connected to the antenna system when t/r relay K101 is closed. This stage is tuned to the operating frequency shown on the KILOCYCLES indicator and is loaded to the antenna system by the adjustment of POWER AMPLIFIER TUNE and POWER AMPLIFIER LOAD controls on the front of RT-671/PRC-47. Optimum adjustment of these controls is indicated by maximum deflection (maximum power output) of XMTR OUTPUT meter M 101 on the front of the receiver-transmitter.

2-7. Frequency Control Circuits (fig. 7-4)

a. The temperature-compensated crystal-oscillator of radio frequency oscillator A6 is an extremely stable standard that provides a 3-MHz output signal for the frequency divider (locked oscillator) circuits of this module. The crystal is contained in a temperature-controlled oven to minimize frequency drift caused by changes in ambient temperature, and the circuit is equipped with an adjustment that permits compensation for long-term crystal aging effects. Transistor Q1 is the oscillator, and transistors Q2 and Q3

provide isolation that enhances overall frequency stability. Locked oscillator Q4 divides the output of the 3-MHz oscillator by six times to provide the 500-kHz standard signal. Part of this output is routed through follower Q7 to locked oscillator Q8 where it is further divided by five to obtain the 100-kHz output signal. This latter signal is amplified by 100-kHz amplifier Q9 before being applied to the 100-kHz pulse generator circuits of oscillator control A7. The remaining portion of the output from locked oscillator Q4 is amplified by 500-kHz amplifiers Q5 and Q6 before being routed to the receiver-transmitter circuits as the 500-kHz standard signal. Part of the output of Q5 is converted to 1-MHz by frequency doubler Q4 in oscillator control A7. This sinusoidal signal is applied to pulse generator Q5-Q6 where it is converted to a 1-MHz pulse-train that is subsequently amplified by Q7 before application to pulse amplifier A19 in signal data translator A3. The output circuit of Q19 is a parallel-resonant tuned circuit that is selectable in 1-MHz increments between 5- and 14-MHz as shown below. Depending upon the selection made by the frequency control knobs on the front panel of RT-671/PRC-47, one whose megahertz channel in this range is made available to the subsequent circuits. A constant amplitude signal is assured by passing this selected frequency through limiters Q16 and Q17 before application to follower Q18.

KILOCYCLES indicator reading	Pulse amplifier Q19 output frequency (MHz.)
XX000 to XX099	1.8
XX100 to XX199	1.7
XX200 to XX299	1.6
XX300 to XX399	1.5
XX400 to XX499	1.4
XX500 to XX599	1.3
XX600 to XX699	1.2
XX700 to XX799	1.1
XX800 to XX899	1.0
XX900 to XX999	0.9

limiters Q17, Q18, and Q19. The spurious frequencies introduced in the output by this limiting are removed by a filter and the remaining signal is routed to follower Q24. The 1.8- to 0.9 MHz output of Q24 is heterodyned with the 5- to 14-MHz output from follower Q18 in signal data translator A6 in diode quad mixer CR10. The difference-frequency that results from this mixing is a single 100-kHz frequency between 3.2 and 13.1 MHz as shown in the following table. This signal frequency is routed through follower Q25 to diode quad mixer CR11 where it is mixed with the hf oscillator output signal that was generated by

KILOCYCLES indicator reading	Pulse amplifier Q 19 output frequency (MHz.)
2000 to 2999	5.0
3000 to 3999	6.0
4000 to 4999	7.0
5000 to 5999	8.0
6000 to 6999	9.0
7000 to 7999	10.0
8000 to 8999	11.0
9000 to 9999	12.0
10000 to 10999	13.0
11000 to 11999	14.0

b. The 100-kHz output of Q9 in radio frequency oscillator A6 is applied to pulse generator Q1-Q2 in oscillator control A7. This pulse generator converts the sinusoidal input into a 100-kHz pulse-train. The output circuit of pulse amplifier Q3 is a parallel-resonant tuned circuit that is selectable in 100-kHz increments between 1.8 and 0.9 MHz as shown in the following table. Depending upon the selection made by the frequency controls on the front panel of RT-671/PRG-47, one single 100-kHz frequency is made available to the subsequent circuits. A constant amplitude signal is assured by passing this selected frequency through

KILOCYCLES indicator reading	Mixer CR output (MHz.)	KILOCYCLES indicator reading	Mixer CR10 output (MHz.)
2000 to 2099	3.2	5500 to 5599	6.7
2100 to 2199	3.3	5600 to 5699	6.8
2200 to 2299	3.4	5700 to 5799	6.9
2300 to 2399	3.5	5800 to 5899	7.0
2400 to 2499	3.6	5900 to 5999	7.1
2500 to 2599	3.7	6000 to 6099	7.2
2600 to 2699	3.8	6100 to 6199	7.3
2700 to 2799	3.9	6200 to 6299	7.4
2800 to 2899	4.0	6300 to 6399	7.5
2900 to 2999	4.1	6400 to 6499	7.6
3000 to 3099	4.2	6500 to 6599	7.7
3100 to 3199	4.3	6600 to 6699	7.8
3200 to 3299	4.4	6700 to 6799	7.9
3300 to 3399	4.5	6800 to 6899	8.0
3400 to 3499	4.6	6900 to 6999	8.1
3500 to 3599	4.7	7000 to 7099	8.2
3600 to 3699	4.8	7100 to 7199	8.3
3700 to 3799	4.9	7200 to 7299	8.4
3800 to 3899	5.0	7300 to 7399	8.5
3900 to 3999	5.1	7400 to 7499	8.6
4000 to 4099	5.2	7500 to 7599	8.7
4100 to 4199	5.3	7600 to 7699	8.8
4200 to 4299	5.4	7700 to 7799	8.9
4300 to 4399	5.5	7800 to 7899	9.0
4400 to 4499	5.6	7900 to 7999	9.1
4500 to 4599	5.7	8000 to 8099	9.2
4600 to 4699	5.8	8100 to 8199	9.3
4700 to 4799	5.9	8200 to 8299	9.4
4800 to 4899	6.0	8300 to 8399	9.5
4900 to 4999	6.1	8400 to 8499	9.6
5000 to 5099	6.2	8500 to 8599	9.7
5100 to 5199	6.3	8600 to 8699	9.8
5200 to 5299	6.4	8700 to 8799	9.9
5300 to 5399	6.5	8800 to 8899	10.0
5400 to 5499	6.6	8900 to 8999	10.1

KILOCYCLES indicator reading	Mixer CR10 output (MHz.)	KILOCYCLES indicator reading	Mixer CR10 output (MHz.)	KILOCYCLES indicator reading	Mixer CR1 output (MHz.)	KILOCYCLE S indicator reading	Mixer CR1 ₁ output (MHz.)
9000 to 9099	10.2	10500 to 10599	11.7	XXX66	634	XXX83	617
9100 to 9199	10.3	10600 to 10699	11.8	XXX67	633	XXX84	616
9200 to 9299	10.4	10700 to 10799	11.9	XXX68	632	XXX85	615
9300 to 9399	10.5	10800 to 10899	12.0	XXX69	631	XXX86	614
9400 to 9499	10.6	10900 to 10999	12.1	XXX70	630	XXX87	613
9600 to 9599	10.7	11000 to 11099	12.2	XXX71	629	XXX88	612
9600 to 9699	10.8	11100 to 11199	12.3	XXX72	628	XXX89	611
9700 to 9799	10.9	11200 to 11299	12.4	XXX73	627	XXX90	610
9800 to 9899	11.0	11300 to 11399	12.6	XXX74	626	XXX91	609
9900 to 9999	11.1	11400 to 11499	12.6	XXX75	625	XXX92	608
10000 to 10099	11.2	11500 to 11-13	12.7	XXX76	624	XXX93	607
10100 to 10199	11.3	11600 to 11699	12.8	XXX77	623	XXX94	606
10200 to 10299	11.4	11700 to 11799	12.9	XXX78	622	XXX95	605
10300 to 10399	11.5	11800 to 11899	13.0	XXX79	621	XXX96	604
10400 to 10499	11.6	11900 to 11999	13.1	XXX80	620	XXX97	603
				XXX81	619	XXX98	602
				XXX82	618	XXX99	601

circuits of signal data translator A3. The difference-frequency resulting from this second mixing is a single 1-kHz frequency between 700 and 601 kHz, as indicated in the table below, that also contains the error increment of the hf oscillator signal. This output is amplified by Q26, filtered, and then further amplified by Q27. The resulting sinusoidal signal is passed through clipper CR9-CR15 to form a square-wave output signal.

c. The output frequency of oscillator Q20 is dependent upon the 1-kHz frequency control selection that chooses an appropriate crystal from Y1 through Y10. These crystals are adjusted so that the oscillator output frequencies between 3.007 and 3.016 MHz are obtained as shown in the following table. Similarly, the output frequency of oscillator Q21 is dependent upon the 10-kHz

KILOCYCLES indicator reading	Mixer CR1 ₁ output (MHz.)	KILOCYCLES indicator reading	Mixer CR1 ₁ output (MHz.)
XXX00	700	XXX33	667
XXX01	699	XXX34	666
XXX02	698	XXX35	665
XXX03	697	XXX36	664
XXX04	696	XXX37	663
XXX05	695	XXX38	662
XXX06	694	XXX39	661
XXX07	693	XXX40	660
XXX08	692	XXX41	659
XXX09	691	XXX42	658
XXX10	690	XXX43	657
XXX11	689	XXX44	656
XXX12	688	XXX45	655
XXX13	687	XXX46	654
XXX14	686	XXX47	653
XXX15	685	XXX48	652
XXX16	684	XXX49	651
XXX17	683	XXX50	650
XXX18	682	XXX51	649
XXX19	681	XXX52	648
XXX20	680	XXX53	647
XXX21	679	XXX54	646
XXX22	678	XXX55	645
XXX23	677	XXX56	644
XXX24	676	XXX57	643
XXX25	675	XXX58	642
XXX26	674	XXX59	641
XXX27	673	XXX60	640
XXX28	672	XXX61	639
XXX29	671	XXX62	638
XXX30	670	XXX63	637
XXX31	669	XXX64	636
XXX32	668	XXX65	635

KILOCYCLES indicator reading	Oscillator Q20 output frequency (MHz.)	KILOCYCLES indicator reading	Oscillator Q20 (MHz.)
XXX00	3.007	XXX05	3.012
XXX01	3.008	XXX06	3.013
XXX02	3.009	XXX07	3.014
XXX03	3.010	XXX08	3.015
XXX04	3.011	XXX09	3.016

frequency control selection that chooses an appropriate crystal from Y11 through Y20. These crystals are adjusted so that the oscillator output frequencies lie between 3.707 and 3.617 MHz as shown in the following table. The output of oscillators Q20 and A21 are mixed in Q22 to obtain a single difference-frequency between 700 and 601 kHz. This reference frequency is routed

kilocycles indicator reading	Oscillator Q21 output frequency (MHz.)	KILOCYCLES indicator reading	Oscillator Q21 output frequency (MHz.)
XXX00 to XXX09	3.707	XXX50 to XXX59	3.657
XXX10 to XXX19	3.697	XXX60 to XXX69	3.647
XXX20 to XXX29	3.687	XXX70 to XXX79	3.637
XXX30 to XXX39	3.677	XXX80 to XXX89	3.627
XXX40 to XXX49	3.667	XXX90 to XXX99	3.617

through a low-pass filter to remove spurious frequencies that may have been generated through mixing, and then it is applied to clippers CR7 CR8. The resulting squarewave is coupled to the adder/phase-shift circuit of the discriminator by follower Q23. A phase-shift circuit is inserted in the signal path from Q23 to discriminator

amplifier Q8 and the reference frequency is summed with the output of clippers CR9-CR15 in the adder. The unshifted output of Q23 is also summed with the output of CR9-CR15 in the adder circuit associated with discriminator amplifier Q11. Transistor pairs Q8-Q11, Q9-Q12, and Q10-Q13 are each carefully selected to provide identical gain in each discriminator channel. When the hf oscillator signal from signal data translator A3 differs only slightly from the reference oscillator signal (by 5 kHz, or less), the envelope of the summed signals in these two discriminator channels will remain out of phase by an amount dependent upon the frequency error between the two signals. The leading edge of the summed signal envelope triggers frequency discriminators Q10 and Q13 so that they operate like a bistable multivibrator at a rate equal to the phase-difference between the two envelopes. The error voltage at the output of these two transistors may be either positive or negative, depending upon whether the hf oscillator signal is higher or lower than the frequency of the reference oscillator signal. The amount of frequency-difference between the two signals determines the amplitude of this dc error voltage. The dc error voltages are applied to voltage-controlled capacitors in the frequency-determining circuits of the hf oscillator in signal data translator A3. As the frequency of the hf oscillator is corrected, the error frequency at the input to the discriminator is reduced and the resulting dc error voltage at the output of this circuit again approaches zero. Coarse frequency control of the hf oscillator is obtained by the adjustment of the frequency control knobs on the front panel of RT-671/PRC-47. The 2.5- to 12.499-MHz hf oscillator signal is isolated and amplified by buffer amplifier Q21 before being routed to follower Q2 and the subsequent circuits. Amplifiers Q6-Q7 and associated follower Q8 provide hf oscillator signals to the receiver-transmitter circuits; while amplifiers Q3-Q4 and associated follower Q5 provide the injection signal for diode quad mixer CR11 in oscillator control A7.

d. In some instances, transients may cause the discriminator circuits of oscillator control A7 to lose capture of the hf oscillator in signal data translator A3. The automatic capture circuit consists of detector CR12-CR13, transistor switch Q28, and relay driver Q29 in association with antilock relay K6 on the main chassis of RT671/PRC-47. As the loss of capture occurs, the voltage drop across emitter resistor R142 decreases; the base of transistor switch Q28 becomes less positive, and Q28 conducts less

than previously. The reduced conduction of Q28 causes the base of relay driver Q29 to become more positive and it conducts. As Q29 conducts, relay K6 is operated and a small dc voltage is applied to the dc error A and dc error B inputs to the varicap control circuit of signal data translator A3. Since this small voltage is used to calibrate the hf oscillator initially, the frequency of this circuit returns to a value within the capture range of the discriminator circuits. After capture is assured, antilock relay K6 is deenergized (as the voltage again appears at the base of transistor switch Q28). The dc error voltages at the output of the discriminator regain control of the hf oscillator frequency-determining circuits and adjust the output frequency accordingly.

2-8. Power Supply Circuits (fig. 7-5 and 7-6)

a. When the 115-volt, 400-Hz ac primary source is used to power the radio set, the cable is attached to the POWER receptacle on the front panel of RT-671/PRC-47 and this voltage is routed to the radio set by fuse F2. A portion of this input voltage is applied to low-voltage transformer T2 in power supply module A5 where the low-voltage circuit steps down this potential, rectifies it, and filters it in conventional bridge-rectifier, capacitor-input LC filter circuits. The resulting 24-volt dc output is routed to audio frequency amplifier A1 and passes through the normally-closed contacts of B + relay K3 to the signal data translator. A conventional series-type electronic voltage regulator, consisting of transistors Q1 through Q3 and their associated circuits, is used to provide a regulated 20 volts dc output. This potential is applied to the continuously energized circuits of the receiver-transmitter, and to the voice-operated circuits of amplifier-modulator A2 and signal data translator A3. An output from low-voltage rectifier CR26 through CR29 provides 26.5 volts dc [unregulated and unfiltered] for circuits in audio frequency amplifier A1, signal data translator A3, and the panel lamps on the front of RT671/PRC-47. A branch of this same circuit arms the push-to-talk relay (A5K1) in the power supply module.

b. A portion of the incoming 115-volt primary power is applied to step-down transformer T2, is rectified by bridge-rectifier CR3 through CR6, and applied to ac power control relay K2. The contacts of this relay route the primary power to high-voltage transformer T1 in power supply A5 whenever POWER-LIGHTS switch S1 on the

front of RT-671/PRC-47 (or a remote control on-off switch) is placed to ON. Push-to-talk relay A5K 1 in the power supply module is operated by any one of the following conditions provided that overtemperature cutout K103 in the power amplifier compartment has not opened: by CW-FSK/VOICE switch S2 (when placed to the CW-FSK position by OPR-TUNE switch S102 (when placed to the TUNE position); and by the handset ptt switch (when it is pressed). Thermal override switch S3B is physically part of BATTERY TEST switch S3A, and it must be held fully depressed to permit operation of the radio set after overtemperature cutout K103 has operated.

c. In the transmit mode, ac power control relay K2 and B + relay K3 in the main chassis of the radio set, and push-to-talk relay A5K1 are all operated. The 115-volt ac primary power is routed through the contacts of K2 and A5K1 to the 115-volt primary winding of high-voltage transformer T1. This primary winding is tapped for operation with the power oscillator described in paragraph 2-8 e. High-voltage transformer T1 contains several secondary windings that provide a variety of ac and dc outputs during transmitter operation. A 6.3-volt ac winding provides heater power for the power amplifier stage and for the rf amplifiers and the driver in signal data translator A3. An additional secondary winding is provided for each of the four rectifier-filter circuits that supply dc potentials to other parts of the transmitter. Rectifier CR1 through CR4 and its associated filter and bias adjusting network provide 110 volts dc and 32 volts dc for the grid circuits of the power amplifier (V101) and the driver (A3V3) respectively. Each of these outputs is individually adjustable to provide optimum operation of the vacuum tube with which it is associated. Rectifier CR6 through CR17 is a fullwave bridge-type circuit employing three diodes in each leg. The output of this rectifier is filtered by capacitor C6 and resistors R6 and R7 to provide 1500 volts dc for the plate circuit of power amplifier V101. Rectifier CR18 through CR21 provides an output that is filtered by capacitors C19 and resistors R9 and R10 and it operates the screen circuit of the power amplifier tube. The rectified output of CR22 through CR25 is routed to the filter circuit consisting of capacitor C20 and resistors R11 and R12. The output of this circuit is applied to the driver stage (V3) of signal data translator A3 and a portion of it is dropped through resistor R8 before being

applied as a 150-volt dc plate and screen voltage to rf amplifiers V1 and V2 of signal data translator A3.

d. When a 26.5-volt dc primary source is used for operation of the radio set, this source is connected to the POWER receptacle on the front of RT-671 /PRC-47 instead of the 115-volt ac power cable. The 26.5-volt incoming power is routed through fuse F1 and the contacts of dc power control relay K 1 to the power supply circuits of the radio set. With no ac power connected, dc power control relay K1 is operated when the POWER-LIGHTS switch (S1) on the front panel of RT-671/PRC-47 (or a remote control on-off switch) is placed to ON. As this relay operates, the contacts in the 115-volt ac circuit are opened, and the contacts associated with the 26.5-volt circuit are closed so that power is applied to: the 26.5-volt dc circuits of audio frequency amplifier A1, signal data translator A3, and the panel lamp circuits on the front of RT-671/PRC47; the filter consisting of inductor L1 and capacitors C25 and C26 to the normally-closed contacts of B + relay K3 to the 24-volt dc circuits of audio frequency amplifier A1; through the normally-closed contacts of B + relay K3 to the 24-volt dc circuits of signal data translator A3; and to voltage regulator Q1 through Q3. The push-to-talk relay in the power supply is armed so that it may be operated by selection of the transmit mode, and regulated dc is routed from the output of the voltage regulator to the 20-volt circuits of the radio set and through the contacts of B + relay K3 to the circuits of amplifier-modulator A2 and signal data translator A3 that are voice-operated.

e. Push-to-talk relay K1 in power supply A5 is operated by selection of the transmit mode. (Refer to paragraph 2-8 b for a detailed discussion of operation of relay K1.) In addition to a contact-pair in the 115-volt ac circuit to high-voltage transformer T1, another contact-pair is associated with the center-tap of this primary winding. As these contacts close, dc power is applied to 400-Hz power oscillator Q1-Q2, and a 26.5-volt, 400-Hz squarewave ac is generated and applied to part of the transformer primary winding. With this square wave voltage applied, operation of the transformer, rectifier, and filter circuits is identical to the description shown in paragraph 2-8 c except that a contact-pair on ac power control relay K1 selects a tap on the 6.3volt ac filament winding of T1 for proper output to the connected vacuum tube filament circuits.

2-9. Audio Frequency Amplifier AM -3506/PRC-47 (A8A1) (fig. 2-5 through 2-7)

a. The audio from the microphone is applied to microphone amplifier Q1 and to the shunt compressor circuit (CR17). After amplification, part of the output signal from Q1 is routed to audio amplifier Q3 and the remainder is amplified in compressor amplifier Q2. The amplified output of Q2 is then coupled by transformer T1 to compressor rectifier CR1 through CR4, filtered by capacitors C3 and C4, and applied as an ungrounded forward bias voltage across compressor CR17. This bridge rectifier assembly is connected so that two variable-resistance paths are available to the incoming audio signal. The amount of forward bias applied by compressor rectifier CR1 through CR4 determines the path

resistance through the diode legs of CR17 so that audio peaks from the microphone input are limited and the amplified output from Q1 remains essentially constant for wide variations in microphone input level. When the incoming audio is a low-level signal, the forward bias applied to compressor CR17 is small and the individual diodes are operated in their high forward-resistance region. As the audio signal increases, the bias voltage from compressor rectifier CR1 through CR4 also increases and the diodes of CR17 operate in a lower forward-resistance region and load the input circuit of microphone amplifier Q1. The operating bias for the carbon microphone element in the handset is obtained from the 20-volt dc power connection. Resistor R3 and capacitor C1 provide decoupling and control the amount of bias applied to this microphone circuit.

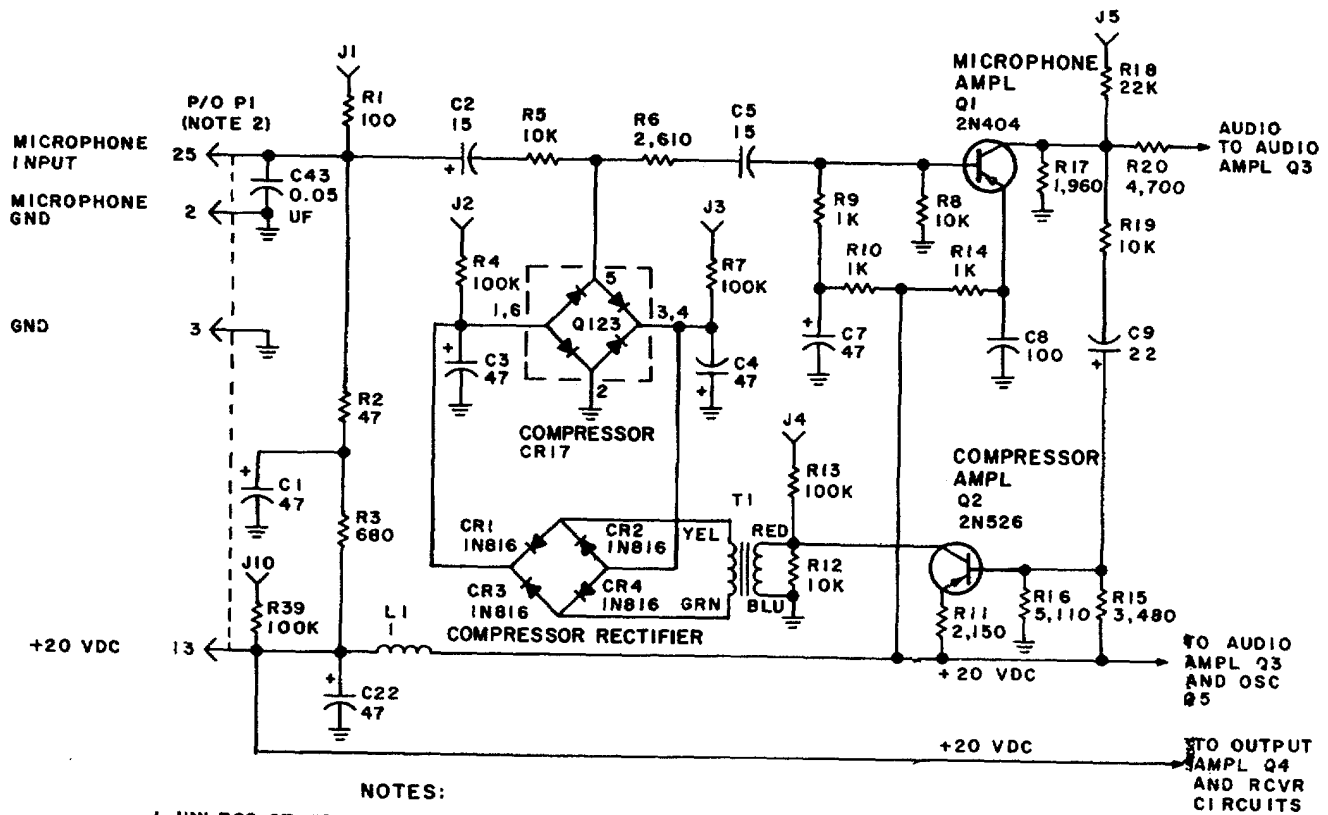

TM5820-509-35-5

Figure 2-5 Compressor/Amplifier Circuit Schematic Diagram.

b. When the radio set is operated in either the cw or fsk mode, or when OPR/TUNE switch S102 is placed in the TUNE position, a ground is

connected to the cw key input (P1-18) and to the audio oscillator circuit. When this ground is connected to the cold end of its tank circuit (L2-

C21, Hartley oscillator Q5 is enabled and an output of approximately 800 Hz is obtained. The oscillator output, or the voice audio from microphone amplifier Q1, is applied to audio amplifier Q3. The resulting amplified output from Q3 is limited by CR5-CR6 and then applied to output amplifier Q4 through microphone amplifier gain control R27. This control is a screwdriver adjustment that establishes the maximum transmit audio output level at the secondary of transformer T2 and connector P1-22. A portion of the output from Q4 is also applied to vex detector CR7-CR8 through vox gain control R40. The resulting positive voltage controls the conduction of vox amplifiers Q6 and Q7. When a minimum threshold voltage is available at the output of CR7-CR8, as determined by the output level of Q4 and the setting of vox gain control R40, transistors Q6-Q7 conduct and relay K1 is energized. The time required to close the vox relay following application of an audio signal to the input of the vox detector is called the attack time. Similarly, the time required for the vox relay to release after removal of the audio signal from the input of the vex detector is called the release, or dropout, time. A fast attack, slow release characteristic is obtained by suitably selecting capacitor C26 and resistor R43, in association with diode CR9. When the audio input level is below the vox threshold, C26 charges through Q6 and R43. When fully charged, nearly

all of the supply voltage appears across C26 so that the base of Q6 is near ground potential and it remains cut off. When the audio input level exceeds the threshold value, however, the base of vex amplifier Q7 is biased more positively and this transistor conducts. The amount of conduction is limited only by the amount of negative feedback in the loop from the collector of Q7 through C26, through the base-emitter junction of Q6, and back to the base of Q7. As Q7 begins to conduct, the negative charge on the base of Q6 rapidly disappears as C26 discharges through the low forward-resistance of CR9. At a point on the discharge curve of C26, however, transistor Q6 reaches cutoff, the negative feedback path to Q7 is opened, and transistor Q7 immediately switches to full conduction. As this occurs, vex relay K1 is operated through the ground supplied by the collector-emitter junction of Q7. When audio input disappears, or the level drops below the threshold established by the circuit, a more negative potential is applied to the base of Q7, and it is driven toward cutoff. Total and immediate cutoff is prevented by the presence of a small positive voltage in the feedback loop, but as C26 charges, a point is reached on the charge curve where nearly all the supply voltage again appears across this capacitor. The base of Q6 again approaches ground, transistor Q7 is again cut off, and vox relay K1 releases.

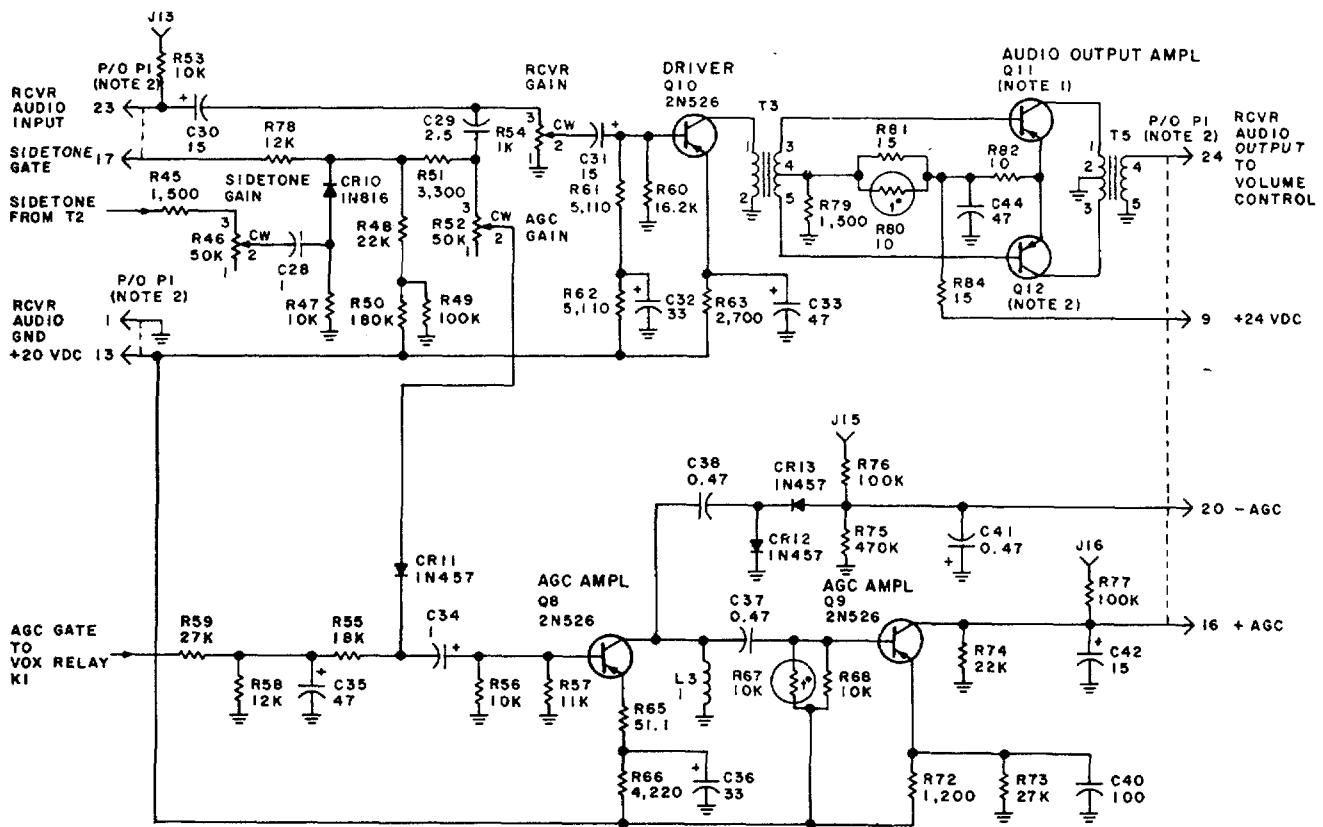

- NOTES:**
1. Q11 AND Q12 ARE MATCHED PAIR TYPE 2N158A, β MATCHED WITHIN 25% AT $I_c = 250$ MA
 2. PI MATES WITH J2 ON CH-474/PRC-47.
 3. UNLESS OTHERWISE INDICATED; RESISTANCE VALUES ARE IN OHMS, CAPACITANCE VALUES ARE IN MICROFARADS AND INDUCTANCE VALUES ARE IN HENRYS.

TM5820-509-35-7

Figure 2.6 Output Amplifier, CW Used

c. Vox relay K1 is also operated by pressing the push-to-talk (ptt) switch on the handset, by placing CW-FSK/VOICE switch S2 to CW-FSK, or by placing OPTUNE switch S102 to TUNE. When any of these controls is operated, push-to-talk relay A5K1 (in Power Supply PP-3518/PRC-

47) is also operated and the high-voltage power supply circuits are energized for transmitter operation. Unless the vex option para 2-1 b) is implemented in Electrical Equipment Chassis CH-474/PRC-47, only push-to-talk operation is permissible with the existing circuits. As vox

relay K1 is energized, the 26.5-volt dc output at P1-7 also operates t/r relay K10I and screen voltage relay K103 in the power amplifier compartment, and B + relay K3, 500-kHz relay K4, and receiver antenna relay K5 in the main chassis of the receiver-transmitter.

d. The receive audio signal from amplifier-modulator A2 is applied to driver Q10 in audio frequency amplifier A1 through receiver gain control R54. This control is a screwdriver adjustment that sets the maximum signal level available at the receiver audio output terminals. Driver Q10 amplifies this incoming signal and routes it through transformer T3 to push-pull audio output amplifier Q11-Q12. The resulting amplified audio signal is applied through transformer T5 and the VOLUME control to the connected audio output device. A portion of the incoming receive audio signal is also applied to agc gate CR11 by automatic gain control R52. Agc gate CR11 is disabled during the transmit period by a reserve bias of 26.5 volts dc that is applied to it from vox relay K1. While disabled, no Agc voltages are available for if. amplifiers Q2 and Q3 of amplifier-modulator A2 or to rf amplifiers V1 and V2 in signal data translator A3. As a result, these stages operate at full circuit gain, using fixed bias during transmit periods. In the receive mode, Agc gate CR11 is enabled, however, and the audio signal from Agc gain control R52 is applied to agc amplifier OR The

output of this amplifier is divided between the +agc circuit containing Q9, and the-agc circuit containing CR12-CR13. Agc amplifier Q9 is biased in the nonlinear region of its operating characteristic and functions as a common-emitter detector. The collector of Q9 is returned to ground through the bias network associated with if. amplifiers Q2 and Q3 in amplifier-modulator A2 and this permits a positive dc voltage to be applied to these stages that is proportional to the average level of receive audio signal. Audio filtering at the output of Q9 is provided by capacitor C42. The other part of the amplified output from Q8 is rectified by detector CR12-CR13, filtered by capacitor C41, and is then applied as a negative bias to the grid circuits of rf amplifiers V1 and V2 in signal data translator A3. Sidetone gate CR10 is enabled in the transmit mode by sidetone bias rectifier CR101 in the power amplifier compartment of the receiver transmitter. When engaged, the sidetone audio from output amplifier Q4 is applied to driver Q10 through sidetone gain control R46 and receiver gain control R54. After the maximum output level of audio output amplifier Q11-Q12 has been established by the setting of R54, the sidetone output available during transmit periods is set by the screwdriver adjustment of R46. In the receive mode, sidetone gate CR10 is disabled and no output from the microphone circuit is contributed to the driver output.

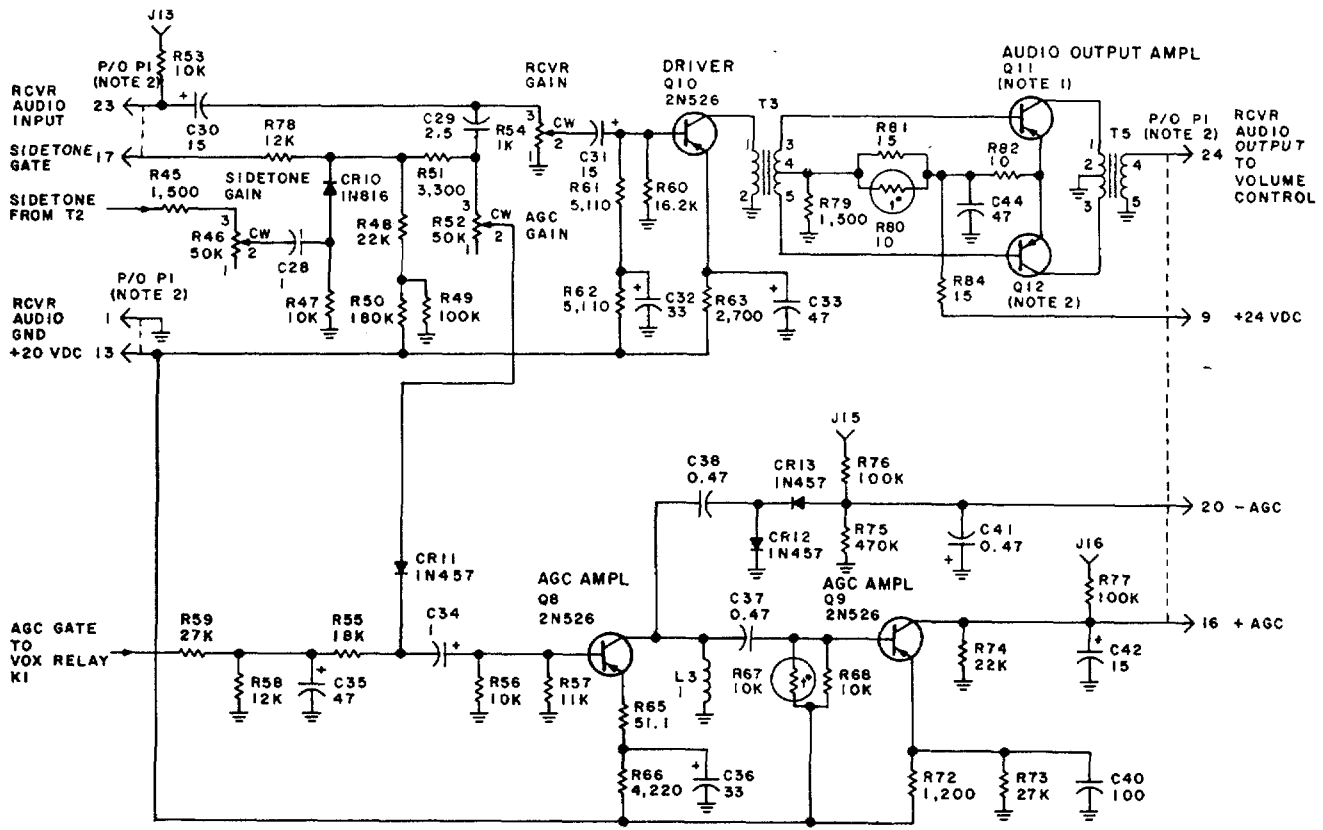

- NOTES:**
1. Q11 AND Q12 ARE MATCHED PAIR TYPE 2N158A, β MATCHED WITHIN 25% AT $I_c = 250$ MA
 2. PI MATES WITH J2 ON CH-474/PRC-47.
 3. UNLESS OTHERWISE INDICATED; RESISTANCE VALUES ARE IN OHMS, CAPACITANCE VALUES ARE IN MICROFARADS AND INDUCTANCE VALUES ARE IN HENRYS.

TM5820-509-35-7

Figure 2-7. Receiver Amplifier, AGC Circuit, and Sidetone Gate, Schematic Diagram.

2-10. Amplifier-Modulator AM 3507/PRC-47 (A8A2) (fig. 2-8 through 2-10)

a. During transmit periods, vox relay A1 K1 is operated and 500-kHz relay K4 (on the main chassis) is also energized. The transmit 500-kHz standard signal from radio frequency oscillator A6 is routed through K4 to the balanced modulator where it is mixed with the transmit audio output of amplifier A1Q4. The output of balanced modulator CR1 through CR4 is a series of pulses whose polarity and repetition rate are determined by the phase and frequency of the 500-kHz standard signal and whose amplitude is proportional to the instantaneous amplitude of the audio input signal. In terms of frequency analysis, the balanced modulator output contains both upper- and lower-sideband signals displaced from the 500-kHz intermediate frequency by the instantaneous audio modulation frequency. The balanced modulator has the familiar diode ring configuration and provides a push-pull output. The diodes of the ring are alternately switched on

and off in parts by the symmetrically-fed transmit 500-kHz standard signal. The output, therefore, consists of a alternate positive and negative 500kHz pulses that constitute the double-sideband, suppressed carrier signal. This double sideband is routed through transformer T2 to alc amplifier Q1. The gain of alc amplifier Q1 is controlled by the +alc and -alc bias voltages that are returned to it from the power amplifier and this assures that the sideband power level at the transmitter output is maintained within the capabilities of the power amplifier tube. alc amplifier Q1 is connected in a common-base configuration and operates normally with only self bias. The +alc bias is a -100-volt dc reference voltage that is applied to the emitter circuit of Q1. The -alc bias is applied to the base of Q1 and is also -110 volts dc except when the power amplifier stage draws grid current (class AB2). When this occurs, the -alc bias becomes more negative and the circuit gain of Q1 is reduced causing a corresponding reduction in the power amplifier driving signal.

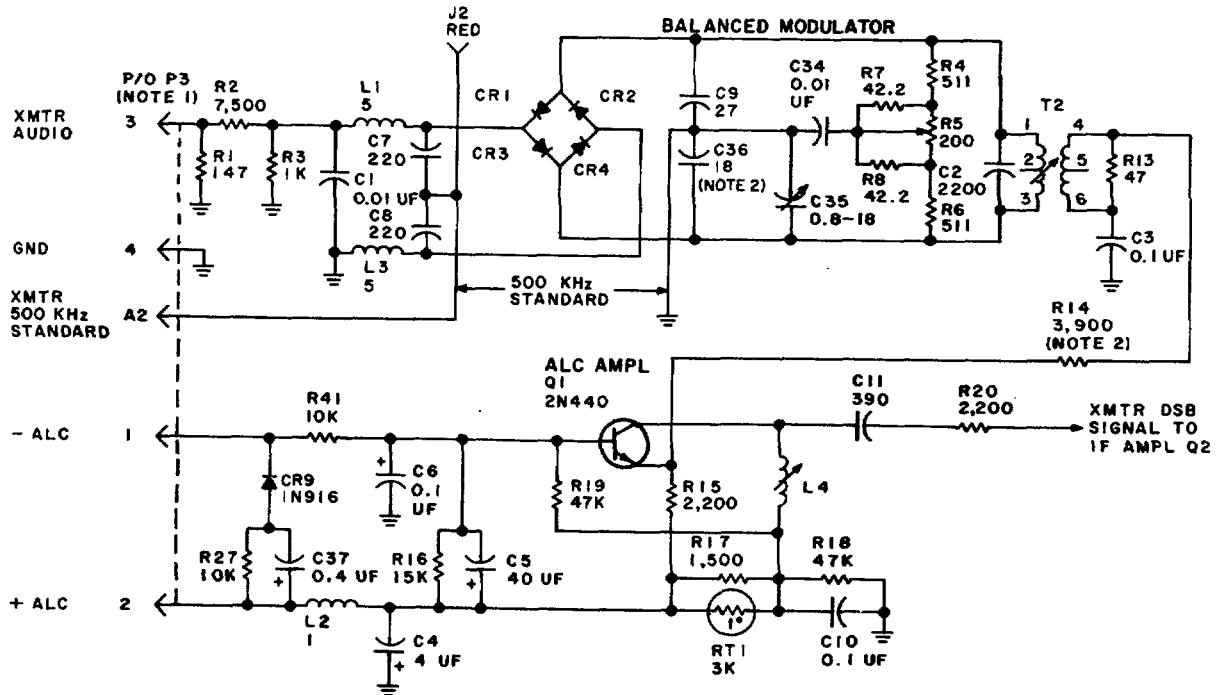

NOTES:

1. P3 MATES WITH J3 ON CH-474/PRC-47.
2. SELECTED IN FINAL TEST, NOMINAL VALUE SHOWN.
3. UNLESS OTHERWISE SPECIFIED; RESISTANCE VALUES ARE IN OHMS, CAPACITANCE VALUES ARE IN PICOFARADS AND INDUCTANCE VALUES ARE IN MILLIHENRYS.

TM5820-509-35-8

Figure 2-8. Balanced Modulator and ALC Circuit , Schematic Diagram.

b. The double-sideband signal from alc amplifier Q1 is further amplified by the common base circuit of if. amplifier Q2 and then applied to the mechanical filter. Bandpass filter FL1 is adjusted to pass only the lower-sideband output of Q2 and

to greatly attenuate the opposite sideband and the 500-kHz standard signal. Further amplification of this lower-sideband signal is obtained in if. amplifiers Q3 and Q4.

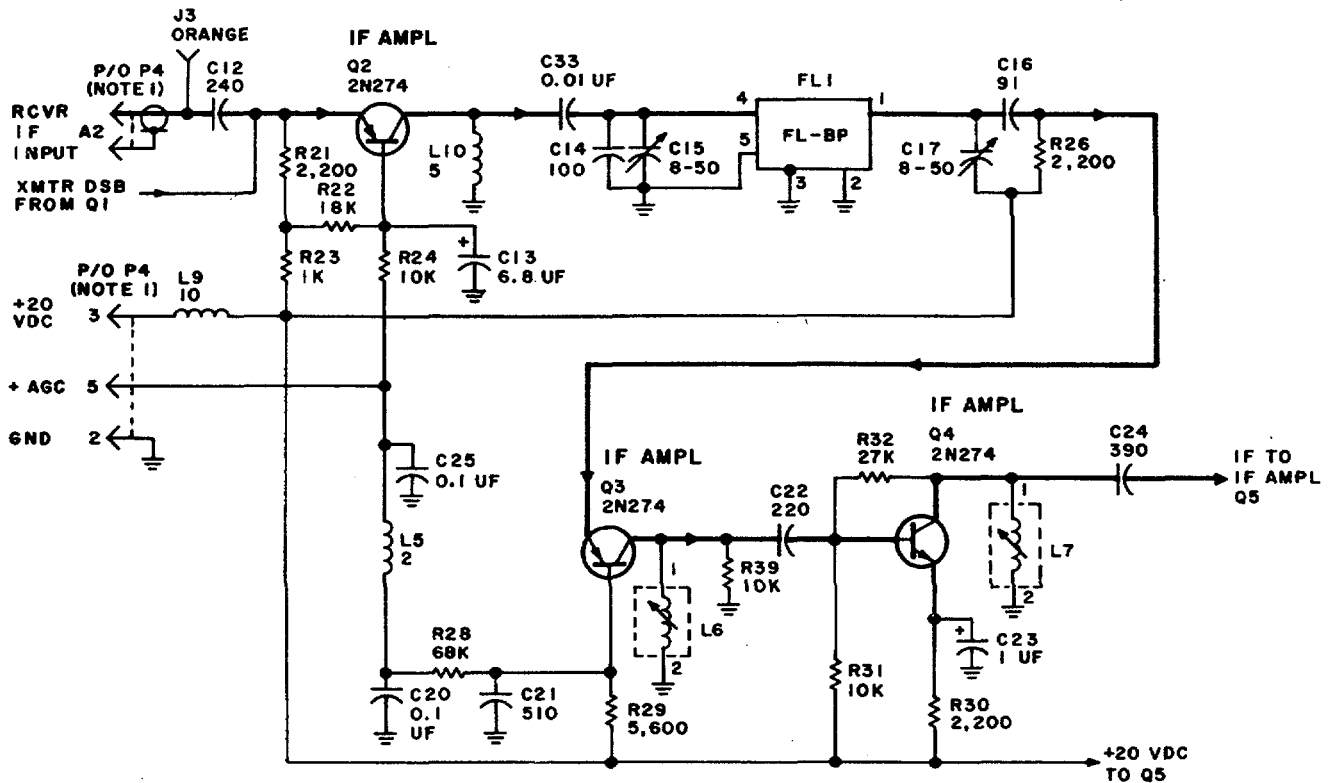

NOTES:

1. P4 MATES WITH J4 ON CH-474/PRC-47.
2. UNLESS OTHERWISE INDICATED; RESISTANCE VALUES ARE IN OHMS, CAPACITANCE VALUES ARE IN PICOFARADS AND INDUCTANCE VALUES ARE IN MILLIHENRYS.

TM5820-509-35-9

Figure 2-9 If. Amplifier Circuit, Schematic Diagram.

c. The intermediate frequency signal from if. amplifier Q4 is further amplified by Q5. The output of this common-emitter amplifier is routed to the normally-open contacts of transmit relay K1, and then by way of transformer T3 to the product detector. In the transmit mode, the 26.5-volt dc potential from vox relay AIK1 operates transmit relay K1 and routes the transmit 500-kHz if. output from P4-A3 to the transmit mixer of signal data translator A3. When the receive mode is selected, however, the receive if. signal from amplifier Q5 is routed to the product detector circuit by transformer T3. Product detector CR7-CR8 consists of two push-pull

connected diode mixers that are alternately switched on and off at the 500-kHz standard signal rate. The receive 500-kHz standard signal is present only when the receive mode is enabled and there is no 26.5-volt vex signal applied to 500-kHz relay K4. The audio component at the output of the product detector is the difference between the instantaneous values of the incoming lower-sideband if. signal and the receive 500-kHz standard signal. This audio output is routed through the low-pass filter consisting of C30, C31, and L8 to remove the remaining if. component before further amplification by circuits in audio frequency amplifier A1

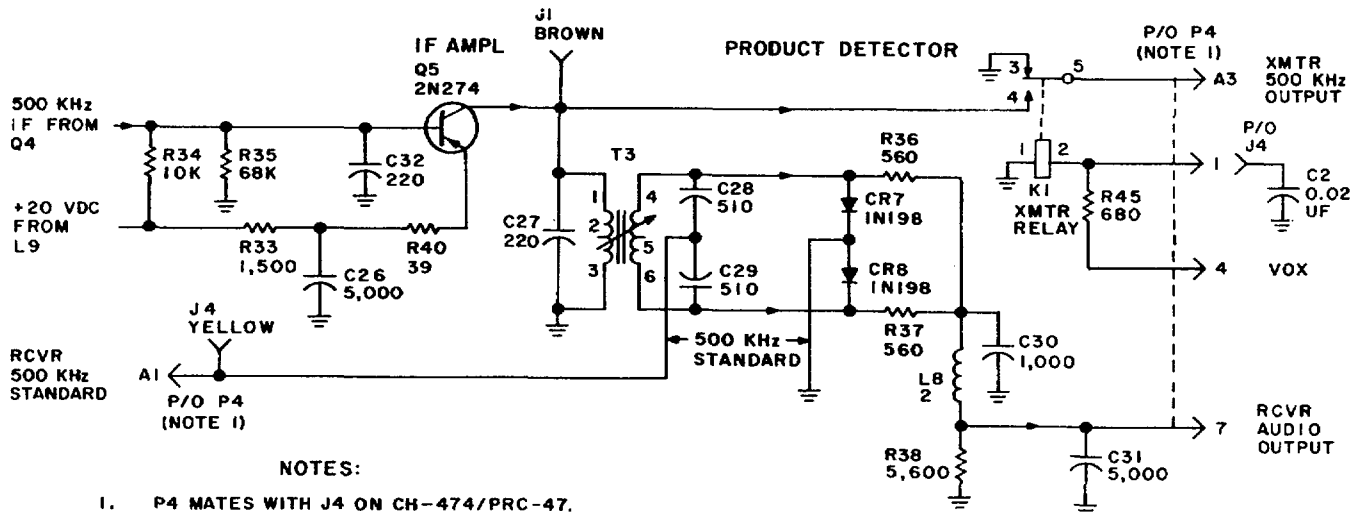

NOTES:

1. P4 MATES WITH J4 ON CH-474/PRC-47.
2. UNLESS OTHERWISE INDICATED; RESISTANCE VALUES ARE IN OHMS, CAPACITANCE VALUES ARE IN PICOFARADS AND INDUCTANCE VALUES ARE IN MILLIHENRYS.

TM5820-509-35-10

Figure 2-10. If. Amplifier and Product Detector Circuit, Schematic Diagram.

2-11. Signal Data Translator CV-1377A/PRC-47 (A8A3) (fig. 2-11 through 2-14, 7-11)

a. Signal data translator A3 contains isolation and amplifier circuits, transmit and receive mixer circuits, the tuned rf amplifier and driver stages, and the hf oscillator and buffer amplifier. Follower Q2 isolates the output of buffer amplifier Q21 and routes the hf oscillator signal through amplifiers Q3 and Q4 to follower Q5 and to the oscillator control circuits (para 2-14d). This 2.5-to 12.499-MHz signal branches at the emitter of follower Q2 and is amplified by Q6 and Q7 before being routed to the transmitter and receiver mixer circuits by follower Q8. At the emitter of Q8, the

hf oscillator signal is again divided with part of it being routed to follower Q12 and the remainder being applied to follower Q13. The appropriate output of these circuits is controlled by the bias voltage that is applied to either the +20 vdc rcvr input or to the +20 vdc xmtr input as B + relay K5 on the main chassis is operated. Application of this bias voltage to Q12 as the receive mode is selected enables the follower and places a forward bias on CR6 that disables this gate. The hf oscillator signal is then routed to the receiver mixer (Q11). When the transmit mode is enabled, +20 vdc smtr input from connector P1-2 is applied to follower Q13 and a forward bias is placed on diode CR5. The transmit mixer input is made operative and the receiver mixer is disabled.

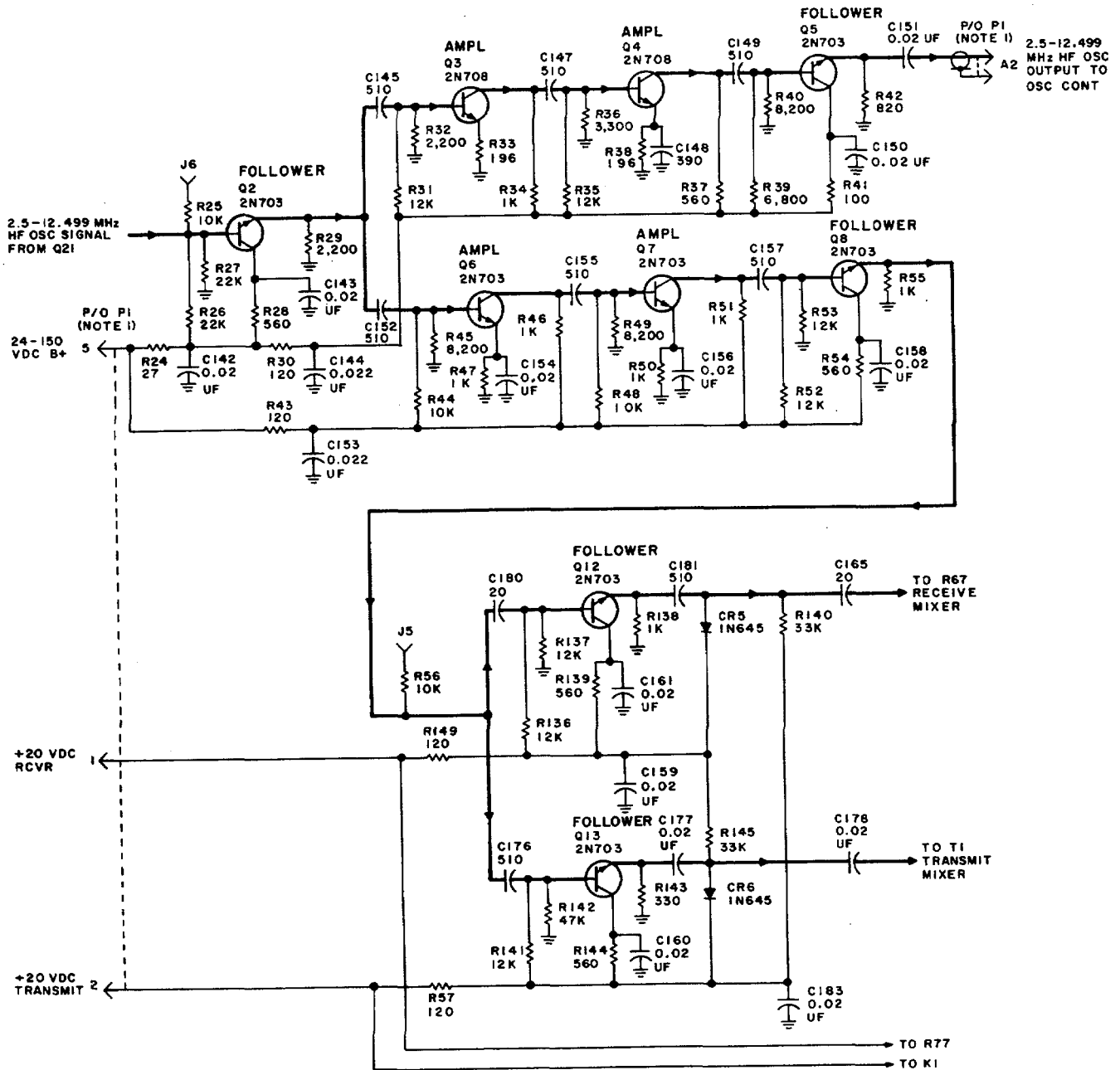

- NOTES:
1. P1 MATES WITH J5 ON CH-474/PRC-47.
 2. UNLESS OTHERWISE INDICATED; RESISTANCE VALUES ARE IN OHMS, AND CAPACITANCE VALUES ARE IN PICOFARADS.

TM5820-509-35-11

Figure 2-11. Isolation Amplifier Circuits, Schematic Diagram.

b. The hf oscillator signal from follower Q 12 is applied to the emitter of receiver mixer Q11 when the receive mode is selected. The incoming receive rf signal from second rf amplifier V2 is routed through the normally-closed contacts of relay K1, through follower Q10, to the base of receiver mixer Q11. The collector of this transistor is tuned to the difference-frequency of these two signals by the parallel-tuned circuit consisting of capacitors C167 through C169 and inductor

L100. Since the enabling bias @ +20 vdc xmtr) is not applied, gate CR2 also remains enabled and this signal is routed through follower Q9 to the if. amplifier circuits of amplifier-modulator A2. During receiver operation follower Q14 and amplifier Q15 are unbiased and remain disabled. As the transmit mode is selected, however, the +20 vdc xmtr bias is applied to P1-2 and transistors Q14 and Q15 are enabled. Forward bias is also applied to gate CR2 so that it is disabled and

to relay K 1. As K1 operates, the transmit rf output from second rf amplifier V2 is routed directly to the grid circuit of driver V3. The transmit if. single sideband signal is applied to the junction of resistors R58 and R59. The hf oscillator signal from follower Q13 is then routed to transformer T1 whose secondary winding contains diode mixers CR3 and CR8. These diodes are switched on and off at the hf oscillator rate and the resulting waveform across R148 is a pulse-train whose repetition rate and polarity are determined by the 500-kHz transmit if. signal.

The absolute level of the difference-frequency obtained by mixing is controlled by transmit gain control R148, and the parallel trap consisting of capacitor C186 and inductor L101 attenuates any 500-kHz standard signal that may remain after mixing. Potentiometer R150 across the secondary winding of transformer T1 is used to balance the transmitter mixer circuit to obtain maximum suppression of the hf oscillator signal. The 2.0 to 11.999-MHz signal produced by the transmit mixer is coupled through follower Q14 and amplifier Q15 to the rf stages (V1 and V2).

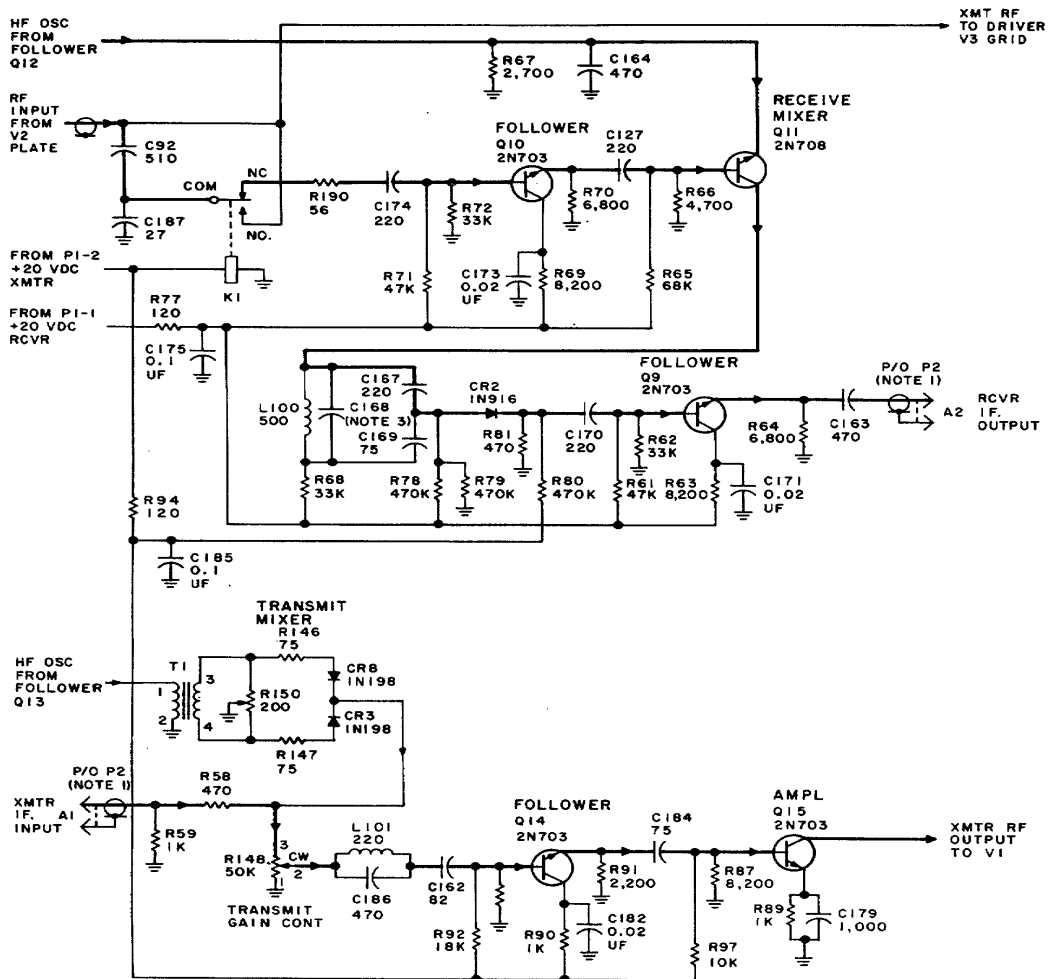

- NOTES:
1. P2 MATES WITH J6 ON CH-474/PRC-47.
 2. UNLESS OTHERWISE INDICATED: RESISTANCE VALUES ARE IN OHMS, CAPACITANCE VALUES ARE IN PICOFARADS AND INDUCTANCE VALUES ARE IN MICRONHENYS.
 3. VALUE OF C168 IS SELECTED IN FINAL TEST.

TM5820-509-35-12

Figure 2-12. Receiver Mixer/Transmitter Mixer Circuits, Schematic Diagram.

c. The rf amplifier and driver stages, as shown in figure 7-12, are conventional vacuum-tube amplifiers with bandswitching plate tank circuits. In the transmit mode, the rf signal from amplifier Q15 is applied to the grid circuit of first rf amplifier V1, routed to second rf amplifier V2, and further amplified by driver V3 before being applied to the grid circuit of the power amplifier stage. The rf amplifier/driver bandswitching circuits are coarse-tuned by adjustment of the whole megahertz frequency control knob on the front panel of the RT-671 /PRC-47. As this selection is made, a switch position is selected that connects an appropriate tuned circuit component to each stage. The bands of frequencies that are selected at each switch position is shown in the following table

Bandswitch position	KILOCYCLES indicator reading (MHz.)
1	2.000 to 2.999
2	3.000 to 3.999
3	4.000 to 4.999
4	5.000 to 5.999
5	6.000 to 6.999
6	7.000 to 7.999
7	8.000 to 8.999
8	9.000 to 9.999
9	10.000 to 10.999
10	11.000 to 11.999

Fine tuning by adjustment of the 100- and 10-kHz frequency control knobs on the front panel of the receiver-transmitter varies the inductance of series coils L1 through L5 and L145 to obtain proper tracking. When the receive mode is selected, the additional tuned circuits associated with bandswitches S1, S2, and S3 are inserted in the grid circuit of the first rf amplifier (V1). These grid circuit components are ganged with the whole megahertz, 100-kHz, and 10-kHz frequency control knobs and are adjusted with the plate circuit components. These additional tuned circuits in the grid of V1 provide greater image

rejection and reduce adjacent-channel interference by improving the input selectivity during receiver operation. Receiver overloading is minimized by the use of automatic gain control techniques. The agc bias applied to the control grid circuits of rf amplifiers V1 and V2 is obtained from circuits in audio frequency amplifier A1 (pare 2-9d).

d. The hf oscillator signal is generated by transistor Q20 using the shunt- and series-tuned circuits associated with bandswitches S6 and S10. Oscillator Q20 is a common-base Colpitts configuration that employ voltage-controlled capacitors in a shunt network across the frequency-determining tank circuit to provide automatic error-correction of the transmitter-receiver operating frequency by compensating voltages developed in the discriminator circuits of oscillator control A7. Coarse frequency control of the hf oscillator (vfo) is provided by ganging the hf oscillator bandswitches with the whole megahertz frequency control shaft that adjusts the rf amplifier and driver circuits. Fine frequency control is provided by application of error-correcting voltages to the error volts A and/or error volts B inputs that control varicaps CR9 and CR10. A small time lag exists between the application of the error voltage by the discriminator circuits of oscillator control A7 and the change in hf oscillator frequency. This is largely due to the slow response of the varicap capacitance. As a result, some over-correction can occur and some hunting exists during the frequency control mode. The 2.5- to 12.499-hf oscillator signal is amplified and buffered by Q21 before application to follower Q2 and the isolation amplifier circuits. Capacitor C344 and slug rack L145 permit the initial hf oscillator frequency settings to be made prior to tracking adjustments. Potentiometer R162 in the base of buffer amplifier Q21 permits the hf oscillator output level to be controlled over narrow limits.

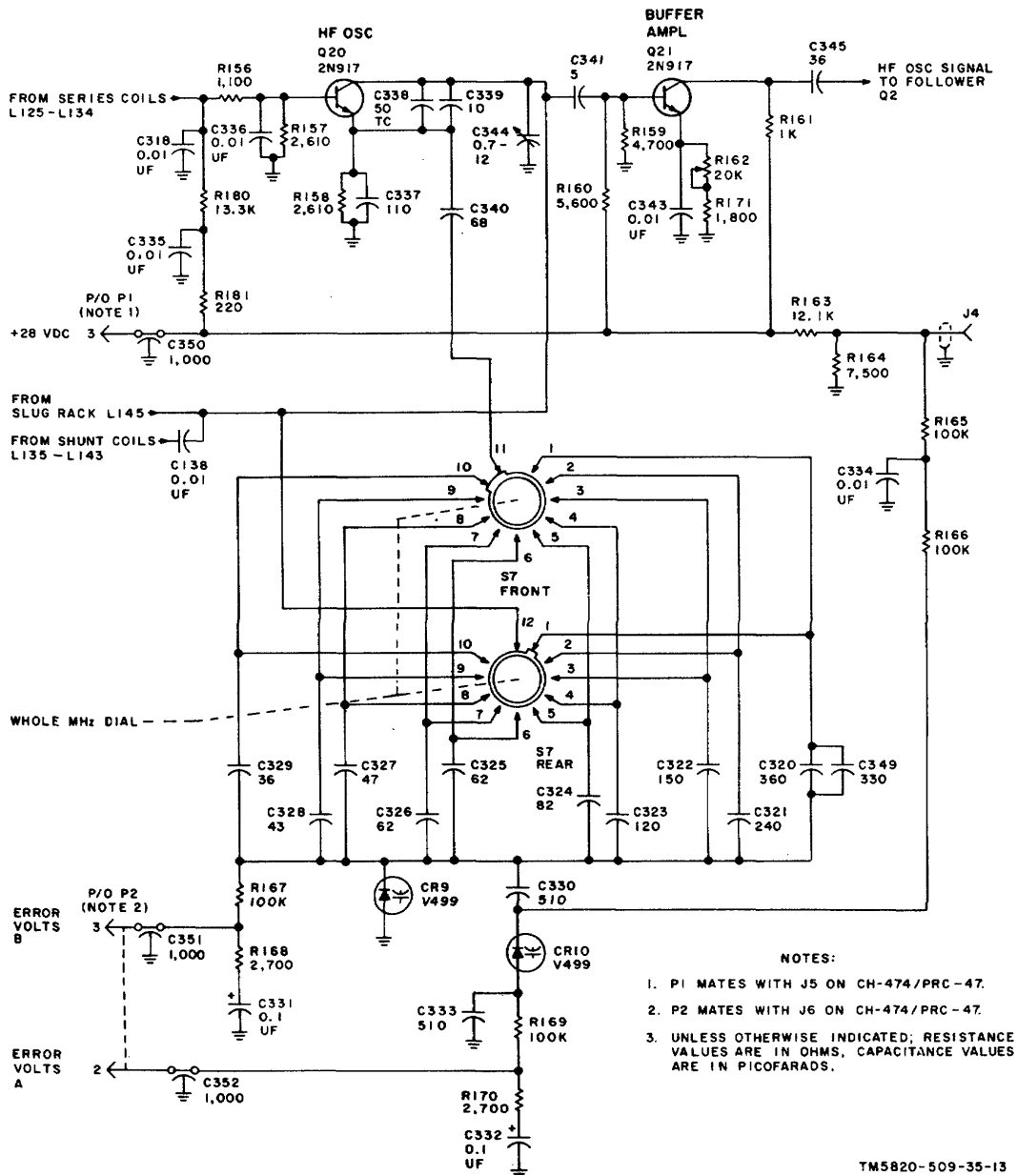

TM5820-509-35-13

Figure 2-13. Hf Oscillator and Varicap Control Circuits, Schematic Diagram.

e. The 1-MHz pulse output from oscillator control A7 is applied to the emitter circuit of pulse amplifier Q19. This grounded-base pulse amplifier provides frequency multiplication since it is biased in its nonlinear character. The natural ringing frequency of the circuit is enhanced by the hi-Q tank components that are selected in 1-M Hz increments between 5 and 14 MHz by the rotation of switch S9. This selection is made by the whole

megahertz frequency control knob on the front panel of RT-671/PRC-47. The output frequency of the pulse amplifier remains in synchronism with the 1-MHz pulses applied to its input, and limiters Q16 and Q17 clip the 5- to 14-MHz output to maintain it at a constant level. The resulting signal is routed to circuits in oscillator control A7 by follower Q18.

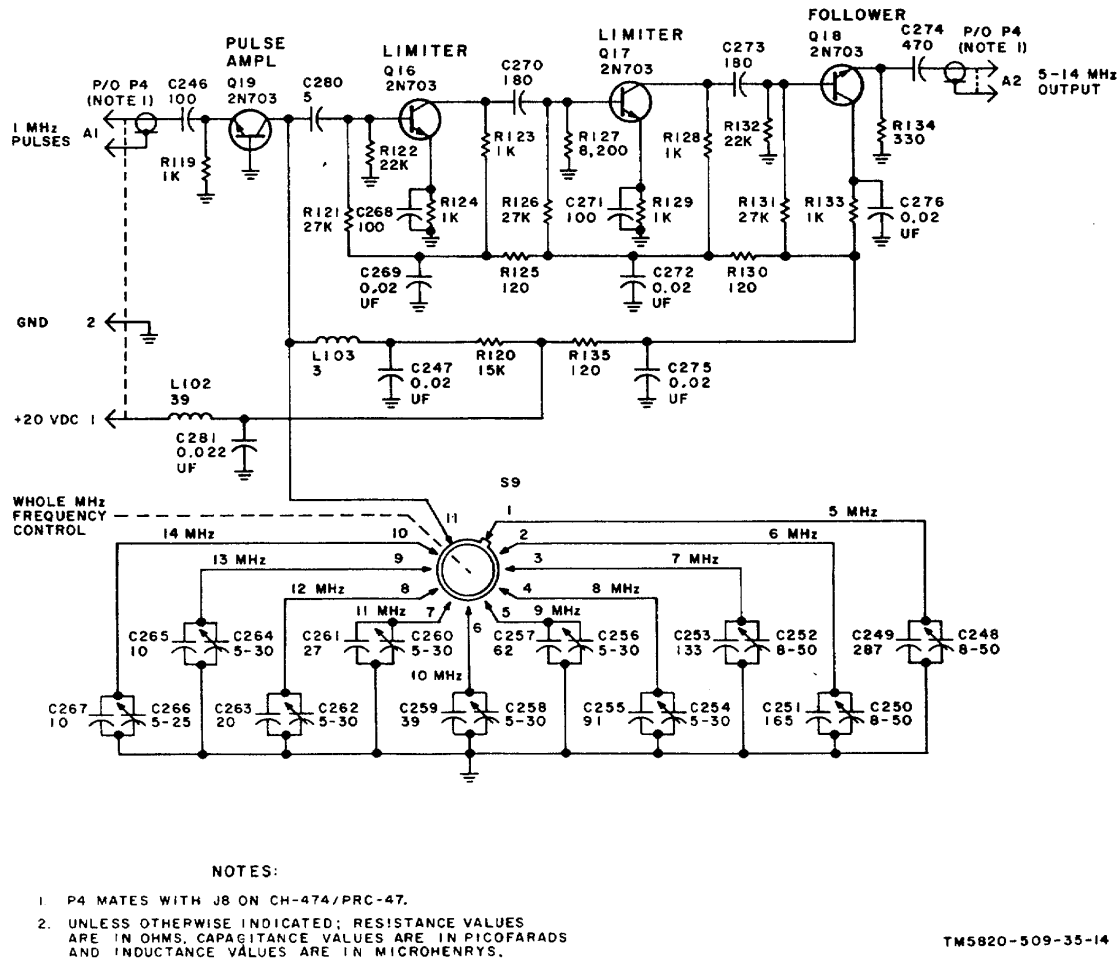

Figure 2-14. 5- to 14-MHz Amplifier/Limiter Circuit, Schematic Diagram.

2-12. Power Supply PP-3518/PRC-47 (A8A5)
 (fig. 7-12)

a. The primary power input circuits to power supply A5 are conventional. Low voltage transformer T2 is energized continuously by the ac primary power source after closure of ac power control relay-K2, but high-voltage transformer T1

is energized only in the transmit mode by operation of the push-to-talk relay (K1). A unique feature of power supply A5 is the same components are used regardless of the type of primary power source connected to the equipment. When an ac source is connected to the input terminals, transformer T2 is energized and

rectifiers CR26 through CR29 supply unfiltered 26.5 volts dc at terminal P1-22. In addition, filtered +24 volts dc and regulated and filtered +20 volts dc are also available from this circuit. During the transmit period, push-to-talk relay K1 is energized by a ground placed on the push-to-talk (ptt) key line (P1-11). As K1 contacts close, ac primary power is applied to terminals 1 and 5 on high-voltage transformer T1. Voltage step-up occurs in all secondary windings of this transformer except those identified by terminals 12, 13, and 14. This winding is used to power the vacuum-tube filament circuits and is a step-down winding. The rectifier filter circuits associated with the secondary windings of high-voltage transformer T2 are conventional. The negative potential furnished by bias rectifiers CR1 through CR4 is filtered by the resistance-capacitance network consisting of R1-C1. The resulting output voltage is divided to permit independent control of the-110-volt dc and the-32-volt dc grid bias potentials required for operation of power amplifier V101 and driver A3V3. Potentiometers R3 and R4 provide moderate adjustment of these levels.

b. When a dc primary power source is connected to the receiver-transmitter, P1-22 becomes +26.5 volts dc input for the low-voltage circuits. Transformer T2 remains deenergized with the dc power source connected, but filter C25-L1-C26 and the associated regulator network are used to provide +24 volts dc and regulated +20 volts dc to the connected circuits just as in the case of ac operation. The power oscillator circuit, located in the main chassis of the receiver-transmitter, operates as an inverter that provides a 26.5-volt squarewave voltage to terminals 2 and 4 of high-voltage transformer T2. Terminal 3 on this primary winding provides a convenient means for applying power to the power oscillator and the insertion of push-to-talk relay K1 contacts in this lead permits proper control during transmit periods.

c. The filtered +24 volts dc from the low-voltage power supply circuit is applied to the voltage regulator input. Zener diode CR31 and resistor R20 provide a reference voltage at the emitter of transistor Q2. The base of this transistor samples the fluctuations in output voltage that appear at the wiper of potentiometer R22, and these variations are amplified by Q1 and Q2 to provide a control bias that controls series regulator Q3. Variations in the bias applied to Q3 produce variations in the collector-emitter current flow of this transistor, and have an effect similar to the addition or removal of a series resistance in

the output circuit to the load. For example, if the output voltage of the regulator begins to rise, current through the base-emitter circuit of Q2 will also increase. The resulting voltage drop across resistor R19 lowers the potential at the base of Q1 and reduces the conduction current in this transistor. The decrease in collector-emitter current flow in Q1 results in a corresponding decrease in conduction current in series regulator Q3. This reduces the output voltage of the regulator terminals to near its steady-state value. The output voltage of the regulator is adjusted by setting potentiometer R22 while monitoring the output voltage at tip jack J8.

2-13. Radio Frequency Oscillator O-I032/PRC-47 (A8A6) (fig. 7-13)

a. The temperature-compensated crystal oscillator circuit provides a highly accurate stabilized oscillator frequency of 3.000 MHz. This circuit consists of transistor Q1 in association with the crystal, inductor L1, and voltage-controlled capacitor C12. Low values of crystal drive (approximately 10 microwatts) are maintained to enhance the long-term stability and to insure that the self-rectified voltage appearing across C12 remains below the minimum required for compensation over the entire operating temperature range. As the ambient temperature varies over considerable limits, crystal frequency drift is maintained below 35 parts-per-million (ppm). Compensation for aging effects in the crystal circuit is provided for by variable capacitor C1. This device permits adjustment of the output frequency by approximately +4 ppm. The correction voltage supplied to voltage variable capacitor C12 is derived from the temperature-sensitive network consisting of thermal resistors RT1 through RT3, and resistors R1 through R6, and R18. The effect of rapid ambient temperature changes on the output frequency of the temperature-compensated crystal oscillator is minimized by the encapsulation of the crystal and its compensating network within a foam insulating block. Amplifier Q2 and follower Q3 isolate the crystal oscillator circuit from variations in loading.

b. The 3.000-MHz output of the temperature-compensated crystal oscillator is applied to a frequency divider circuit. Locked oscillator Q4 provides an output that is one-sixth of the input frequency but remains in synchronism with this input signal. The natural frequency of locked oscillator Q4 is determined by the network consisting of capacitors C13 through C16 in

association with Inductor L3. These capacitors form a voltage divider network that not only provides a convenient means for obtaining a positive feedback voltage for the emitter circuit, but also permits selection of the proper output voltage for subsequent stages. The output of 500. kHz amplifier Q5 is divided with part of the signal being routed to the 1-MHz pulse generator circuit of oscillator control A7 and the remainder passing through 500-kHz amplifier Q6 before being applied to the balanced modulator and product detector circuits of amplifier-modulator A2. Both Q5 and Q6 are conventional amplifier circuits that have tip jacks provided in each output path to facilitate measurement of output levels and waveforms.

c. The 500-kHz signal from locked oscillator Q4 is also routed to the 100-kHz circuits. Follower Q7 provides isolation before applying this signal to Q8. A frequency division of five occurs in locked oscillator Q8 with the natural period of five occurring in locked oscillator Q8 with the natural period of this stage being determined by the network consisting of capacitors C28 through C31 in association with inductor L7. The capacity voltage-divider in the output of this stage also provides taps for conveniently obtaining positive feedback voltage for the emitter circuit, and provides proper output voltage for following stages. The 100-kHz signal from Q8 remains in synchronism with the input signal and hence the 3.000-MHz crystal oscillator output. 100-kHz amplifier Q9 is a conventional circuit that routes the output of Q8 to the 100-kHz pulse generator circuit of oscillator control A7 and effectively isolates these circuits.

2-14. Oscillator Control C-4311JPRC-47 (A8A8) (fig. 2-15 and 7-14)

a. Oscillator control A7 contains pulse generator circuits, tuned amplifier/limiter circuits, crystal oscillator/mixer circuits, and a two-channel discriminator. The 500-kHz standard signal from A6Q5 is applied to the 1-MHz pulse generator circuit consisting of transistors Q4 through Q6 and their associated components. Following amplification by Q7, the resulting 1-MHz pulse train is applied to the 5- to 14-MHz amplifier circuits of signal data translator A3. The 1-M Hz pulse generator circuit consists of frequency doubler Q4, pulse generator Q5-Q6, and amplifier Q7. Doubler Q4 is operated in the nonlinear portion of its characteristic to produce an output rich in harmonics of the 500-kHz input signal. The tuned circuits consisting of capacitors C14 and C15 in association with inductor L1 is resonant at the second harmonic of the input signal and provides an output of 1-M Hz.

Transistors Q5 and Q6 are arranged in a Schmitt trigger circuit that uses inductor L2 for a common emitter load. The inductor maintains a constant dc emitter current (common mode current) that flows in each transistor as they are alternately switched at a 1-MHz rate. The resulting pulse train is amplified by Q7 before being routed to signal data translator A3.

b. The 100-kHz signal from amplifier A6Q9 is applied to the 100-kHz pulse generator circuits consisting of pulse generator Q1-Q2 and pulse amplifier Q3. Transistors Q1 and Q2 form a Schmitt trigger circuit that provides a squarewave output at the 100-kHz switching rate. The coupling network that interconnects Q2 with the base of pulse amplifier Q3 differentiates this squarewave signal and produces both positive-going and negative-going pulses at the base of Q3. Limiter CR1 conducts during the negative-going transitions and shorts these pulses to ground, but during the positive-going transitions, the pulses ring the parallel-resonant tank circuit contained on the 1.8- to 0.9-MHz tuned-circuit board. Switch S3 in the 1.8- to 0.9-MHz tuned-circuit assembly is controlled by the 100-kHz shaft associated with the middle frequency-control knob on the front of the receiver-transmitter. The selection made by this knob resonates the parallel circuit to enhance the pulse amplitude applied to the amplifier-limiter circuits. Transistors Q7 through Q19 clip and amplify the sinusoidal output of pulse amplifier Q3 to assure that a constant level is maintained across the entire frequency range from 1.8 to 0.9-kHz. Spurious frequencies introduced by limiting are attenuated by the bandpass filter consisting of capacitors C66 through C70 and inductors L16 through L18 that are connected across the output of transistor Q19.

c. Crystal oscillators Q20 and Q21 are conventional common-emitter circuits that have a bandswitching turret in each base. The crystals associated with switch S1 are selected by the position of the shaft associated with the 1-kHz frequency-control knob on the front panel of the receiver-transmitter. The crystals associated with switch S2 are selected by the position of the 10-kHz shaft associated with the middle frequency. control knob on the front of the RT-671/PRC-47. The output signals from oscillators Q20 and Q21 are combine in mixer Q22 to provide one-hundred 1-kHz channels between 601- and 700-kHz. The circuit duality of these oscillators and a similarity of temperature coefficient for 811 crystals associated with these oscillators provides an

essentially drift-free output frequency at Q22 This output is routed through the bandpass filter consisting of capacitors C105 through C109 and inductors L24 through L26 to remove any spurious frequencies that may have been introduced in the desired signal due to mixing. The 700- to 601-kHz signal is clipped by limiter CR7-CR8 to form a squarewave that is coupled to the discriminator circuit.

d. The 0.9- to 1.8-MHz signal from limiter Q19 is routed through follower Q24 before being heterodyned in diode quad mixer CR10 with the 5- to 14-MHz signal from Q18 in signal data translator A3. Since each of these input signals is variable (depending on the setting of the KILOCYCLES indicator on the front panel of the receiver-transmitter), the output of mixer Q10 is also variable and may be any 100-kHz channel between 3.2- and 13.1-MHz. This output frequency is routed through follower Q25 and further mixed in diode quade CR11 with the hf oscillator signal from Q5 of signal data translator A3. The difference-frequency at the output of mixer CR11 is also variable and may be any 1-kHz channel between 601- and 700-kHz. This signal contains an increment of hf oscillator error frequency. The mixer output is amplified by Q26, filtered by the circuit consisting of capacitors C169 through C177 in association with inductors L29 through L32. Further amplification is obtained by Q27 before routing the signal to forward-limiting clipper CR9-CR15. The squarewave output of this clipper is applied to both channels of the discriminator circuit.

e. The discriminator circuit has two modes of operation: the frequency control mode, and the phase control mode. When the hf oscillator output frequency is within 50 kHz of the reference standard the discriminator is said to be in the frequency control mode and it compares the 601-to 700-kHz reference signal from follower Q23 with the 601- to 700-kHz (plus hf oscillator error) signal from clipper CR9-CR15. The resulting dc output is applied to the varicap control circuit of signal data translator A3 to reduce the hf oscillator error toward zero. When the difference between the hf oscillator output frequency and the reference signal is less than approximately 5 kHz, the discriminator assumes the phase control mode. In this mode, the circuit monitors the changing phase-difference between the two input signals and corrects the error voltages until this phase-difference approaches zero. When the phase error is zero, the hf oscillator output frequency is identical with the reference oscillator output frequency. Discriminator channel A

consists of the circuits associated with transistors Q8, Q9, and Q10, while channel B consists of the circuits associated with transistors Q11, Q12, and Q13. Selection of these transistors into matched pairs and the careful adjustment of bias and coupling components in these two channels assures nearly identical stage gains in each of the two signal paths. Capacitor C21 and resistor R34 form a phase-shift network in the reference signal path from follower Q23 to the input of Q11. The reference signals are summed with the unshifted output of clipper CR9-CR15 in both channels and the resulting signal at the output of Q8 and Q11 is similar to the waveform shown at the top of figure 2-15. The repetition rate of these two envelopes is

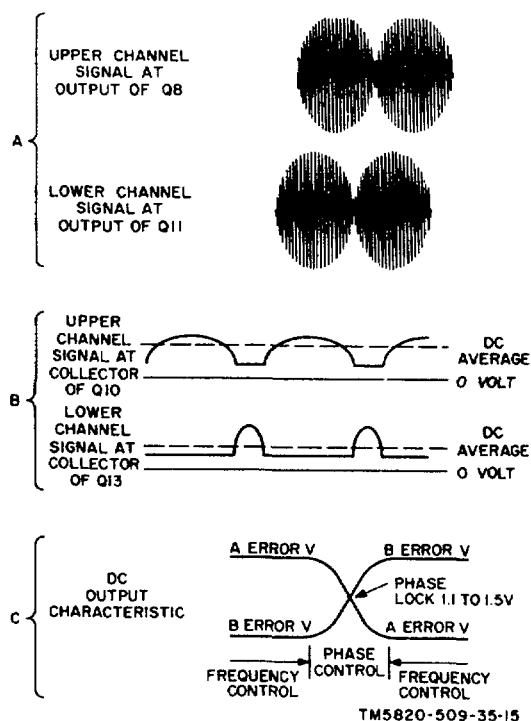

Figure 2 -15 Discriminator Circuit Waveforms.

equal to the difference between the two input frequencies and represents the frequency error associated with the hf oscillator. Either envelope may lead the other along the time base, depending upon whether the hf oscillator frequency is higher or lower than the reference frequency. The outputs of amplifiers Q8 and Q 11 are further amplified by Q9 and Q12 respectively and the individual signals are then detected by diodes CR3 and CR4. In the frequency control mode, the leading edge of the envelope in each channel is used to trigger transistor-pair Q10-Q13 so that they alternately conduct. These transistors operate as a bistable multivibrator with a switching rate equal to the repetition rate of the envelope in each channel. The resulting clipped

envelope at the collector of these transistors is similar to the center waveforms in figure 2-15. {It should be recalled that the waveforms can be reversed depending upon whether the upper channel leads the lower channel, or vice versa.} The integrator circuit at the output of Q11 (C93-R104) and at Q13 (C92-R103) change the output waveshape into dc levels known as error voltage A and error voltage B respectively. (The mnemonic used has no real significance except to differentiate between the respective channels and their outputs.) In the phase control mode, the envelope frequency will approach zero and the bistable switching of transistors Q10 and Q13 will stop. The error voltages at the output of the discriminator will be equal to the dc envelope values, and will vary as the phase-difference between the two channels varies. The phase control mode continues until the phase-difference between the hf oscillator and the reference oscillator is constant. At this time, the phase-difference is equal to the fixed phase-shift introduced by network C21-R34 at the input to transistor Q8, and the voltages at the error A and error B outputs are approximately 1.5 volts dc as indicated in the lower waveform of figure 2-15. (The waveforms used to illustrate the operation of the discriminator circuits are not continuously available for measurement at signal test points, but are only present during brief intervals immediately following a channel selection.)

f. A portion of the signal applied to the base of transistor amplifier Q27 is developed across emitter resistor R142. This signal is rectified by voltage-doubler CR12-CR13 in the automatic capture circuit and is applied to the base of dc amplifier Q28. The resulting positive voltage causes conduction of Q28 whose output clamps the base of transistor switch Q29 at a positive level just below that required for its conduction. If no signal is present at the emitter of Q27, dc amplifier Q28 is turned off and the positive voltage at the base of transistor switch Q29 rises causing this transistor to conduct. The ground supplied through the collector-emitter junction of Q29 is applied to antilock relay K6 on the main chassis of the receiver-transmitter and this relay is operated. As K6 contacts close, a voltage of approximately 10 volts dc is applied to the error A and the error B inputs to the varicap control circuit in signal data translator A3. Since this fixed voltage condition is also the calibrating condition for the hf oscillator, the output error is reduced and capture is once again obtained. After capture, a voltage-drop again appears across the emitter resistor (R142) of Q27 and transistor Q29

is again turned off so that the discriminator may again assume control of the error-correction circuits of the hf oscillator.

2-15. Electrical Equipment Chassis CH-474/PRC-47 (A8A4) (fig. 7-8)

a. When a dc power source is connected to the receiver-transmitter, and dc power control relay K1 is operated, +26.5 volts dc is applied to capacitor C1 and diodes CR1 and CR2 of the power oscillator circuit. As the push-to-talk relay (A5K1) is energized, the +26.5 volts dc is routed through its contacts and the primary winding of high-voltage transformer A5T1 to the emitter circuits of Q1 and Q2. Any difference in the operating characteristics of these two transistors will cause a slight potential difference to exist between their emitters. This difference is coupled to their respective base circuits by the windings of saturable reactor T1, and causes one transistor to conduct more heavily than the other. For example, suppose that the emitter of Q2 is initially a little more positive than the emitter of Q1. This voltage is coupled through reactor T1, and causes the base of Q2 to become more positive and its conduction is reduced. At the same time, the transformer-action of T1 places a slightly less positive charge on the base of Q1 and the conduction of this transistor is increased. The regenerative action continues until the core of reactor T1 is saturated, and then the flux-change ceases. At this point, the bias is removed from the base of each transistor, the magnetic flux in the core collapses, and the regenerative cycle begins in the reverse direction. The period required for a complete cycle is dependent upon the core properties of the reactor and the dynamic characteristics of the two transistors. The squarewave generated in the primary winding of high-voltage transformer A5T1 is approximately 400-Hz. Diodes CR1 and CR2 limit the voltage swing of each emitter lead hence the peak voltage applied to the primary winding of A5T1) to about 26.5 volts peak.

b. During the transmit cycle, the rf output of driver A3V3 is applied to the grid circuit of power amplifier V 101 This single-sideband signal is amplified by V101 and routed through the power amplifier LOAD-TUNE circuit and the t/r relay to the connected load. The grid bias for the power amplifier is derived from the-110-volt dc output of bias rectifier CR1 through CR4 in power supply A5. The level of the rf input signal at the power amplifier grid circuit is controlled so that maximum drive can be used without introducing

excessive distortion in the transmitted signal. This automatic level control (alc) is accomplished by reducing the gain of the transmit if. input signal whenever excessive drive is detected at the power amplifier grid circuit. The (alc) voltage is developed across grid resistor R104 whenever the power amplifier draws grid current (class A B2 operation), and this negative bias is added to the -110 volts dc used as a reference and the combined total (alc) sample controls the gain of (alc) amplifier Q1 in amplifier-modulator A2.

c. An rf voltage sample is taken from the plate circuit of the power amplifier across the voltage divider consisting of capacitors C105 and C144. This sample is routed to the filament centertap of driver V3 in signal data translator A3 as a negative feedback that improves the linearity of the rf output signal. Another voltage sample is taken from the power amplifier plate circuit across capacitor voltage divider C124-C140. This sample is rectified by sidetone rectifier CR101, filtered by capacitors C125, C126, and resistor R108, and applied as an enabling bias to sidetone gate CR10 in audio frequency amplifier A1. XMTR PWR switch S103 on the front panel of the receiver-transmitter selects the appropriate XMTR OUTPUT meter range, power amplifier control grid bias, and power amplifier plate and screen voltages to assure linear operation of this circuit at reduced power levels during tune-up and preliminary loading adjustments. In the LOW

power mode , the amplifier plate voltage is limited to +650 volts dc (derived from the normal screen voltage power supply) and the screen voltage is correspondingly reduced to limit the screen-grid dissipation to reasonable values during periods of off-resonance operation. The rf current flowing in the output circuit of the power amplifier stage is monitored by XMTR OUTPUT meter M101 to determine when proper resonance conditions exist in the output coupling network. Current bias former T101 samples the output rf and develops a voltage across resistor R129 that is proportional to this current. Diode CR102 rectifies this rf voltage and applies it to meter sensitivity adjustment (M ADT) R117. Diode CR103 protects the meter from voltage overloads, and capacitor C106 bypasses rf currents around the meter movement. When the BATTERY TEST switch on the front panel of the receiver-transmitter is pressed, XMTR OUTPUT meter M101 measures the terminal voltage of the connected batteries. Closure of this switch also overrides thermal cutout K103 for emergency operation of the receiver-transmitter during overtemperature conditions in the power amplifier compartment. The POWER AMPLIFIER LOAD and POWER AMPLIFIER TUNE controls operate inductors L109 through L112 and the whole megahertz control selects an appropriate shunt capacitor from the group C108 through C121 to terminate the power amplifier plate circuit impedance.

CHAPTER 3

DIRECT SUPPORT MAINTENANCE

Section I GENERAL TROUBLE SHOOTING TECHNIQUES

WARNING

Avoid contact with the high-voltage circuits and the antenna terminal of the radio transmitter-receiver while performing trouble isolation procedures: personal injury may result.

3-1. Scope

a. *General.* The troubleshooting procedures outlined in this section are to be performed at the direct support (DS) maintenance level. Complete troubleshooting procedures for the radio set beginning at the operational level which are described in TM 11-5820-509-12. The operational tests listed in the preventive maintenance checks and service charts enable the organizational maintenance technician to sectionalize some types of malfunction to specific functional units of the radio set. Additional test facilities and special maintenance equipment are available at the direct support level that provide more conclusive test results for sectionalizing the problem within a unit. Once the trouble has been sectionalized, the functional nature of the problem (whether audio, control, etc) will enable the maintenance technician to further isolate the malfunction to a particular circuit or component. When the sectionalizing test results indicate a malfunction within the receiver-transmitter subassembly, the delayed trouble-isolation procedures shown in Section II should be observed.

b. *Organization.* The first step in servicing a defective radio set is to sectionalize the fault to a specific unit or section of the equipment. In complex equipments consisting of more than one functional unit or inter-related circuitry, the fault must first be isolated to a specific unit or group of circuits within a functional unit. Once this has been accomplished, isolation to a specific circuit and then to a component level may be pursued. It is seldom possible to observe a symptom, diagnose the cause, and immediately locate the defective part unless a part shows obvious physical damage. Generally it is necessary to perform a sequence of operational checks, observations, and measurements before the problem components are isolated. This sequence of steps is called sectionalizing, localizing, and fault isolation.

c. *Sectionalizing.* The AN/PRC-47 consists of a receiver-transmitter, storage batteries, antenna systems, handset, headset, telegraph key, loudspeaker, and interconnecting cables. In all probability the organizational level will have eliminated most of the accessory items as possible trouble sources and the receiver-transmitter will remain for the direct support maintenance technician. Substitution of a suspected accessory item or a receiver-transmitter subassembly (module) with one of known integrity will often eliminate a tedious series of detailed checks and measurements. The operational tests described in the intermediate preventive maintenance checks and services portion of TM 11-5820-509-12 will aid the maintenance technician to sectionalize the source of trouble at this maintenance level.

d. *Localizing.* Once the trouble has been sectionalized to a functional unit or group of circuits, the next step is to localize it to a specific circuit within this area. In the case of the receiver-transmitter, the steps required to isolate the malfunction are relatively difficult because of the complexity and interdependency of the circuits involved. These steps are supplemented by the following general procedures.

(1) *Observation.* Observation involves a thorough understanding of the receiver-transmitter, circuits and may include such subjects as whether the fault occurs only during the transmit mode, whether the problem occurs only at certain frequencies, or whether the problem occurs only in the voice mode.

(2) *Troubleshooting Chart.* The troubleshooting charts contained in Section II assist the technician in performing bench tests on the radio. The instrumentation used for the bench tests assists the technician in performing operational evaluation of the equipment without providing cumbersome antennas and difficult test setups.

(3) *Special Tests.* Special tests including resistance and continuity measurements, signal tracing techniques and signal waveform displays

are included in section II to aid the maintenance technician in localizing an equipment malfunction.

e. *Isolation.* After the trouble has been localized to a stage or a circuit, the final step is to isolate the malfunction to a specific component. Methods for performing this procedure include:

(1) *Visual Inspection.* Examine all resistors, capacitors, vacuum tubes, transistors, coils, and other components associated with the faulty circuit for evidence of broken wires, burned insulation, and other obvious signs of physical damage.

(2) *Voltage and Resistance Measurements.* The voltage and resistance measurements provided in section II aid in determining

whether normal values are being obtained and point out the part of a specific circuit that may be defective.

(3) *Electrical Inspection.* The dc resistance of transformers and coils is shown in tabular form in section II to aid the maintenance technician in determining whether a winding is defective.

3-2. Tools, Test Equipment, and Materials Required

The following table lists the test equipment required for troubleshooting Radio Set AN/PRC-47 at the direct support maintenance level. This list also shows the technical manual identification number for each item specified.

Test Equipment	FSN	Technical manual
Multimeter ME-26A/U Oscilloscope AN/USM-50 Signal Generator SG-103/URM-25F Frequency Counter AN/URM-79/U Audio Oscillator TS-382/U Dummy Load DA-75/U Cable Assembly Set AN/PRA-4 Output Meter TS-585/U Radar and Radio Repair Tool Kit TK-87/U	6625-542-8407 6625-246-8729 5995-973-3686	11-6625-200-15 11-5129 11-6625-935-12 11-5017

Cable Assembly Set AN/PRA-4 (fig. 3-84) is used whenever the procedure requires measurement or adjustment within a module, and includes

an antenna simulator and input/output cables that simplify the bench testing procedures.

Qty	Nomenclature	Manufacturer's part number	Use
1	Special extender cable no. 1	549-6255-00	Extends Power Supply PP 3518/PRC 47 from main chassis.
1	Special extender cable no. 2	549-6256-00	Extends Audio Frequency Amplifier AM 3506/PRC-47 from main chassis.
1	Special extender cable no. 3	549-6257-00	Extends Oscillator Control C 4311/PRC 47 from main chassis.
4	Special extender cable no. 4	549 6258-00	Extends Signal Data Translator CV 1377A/PRC 47 (4 reqd), Oscillator Control C 43 11 /PRC -47 (1 reqd), or Amplifier Modulator AM 3507/PRC-47 (1 reqd) from main chassis.
1	Special extender cable no. 5	549-6259-00	Extends Amplifier-Modulator AM-3507/PRC 47, or Radio Frequency Oscillator O 1032/PRC-47 from main chassis.
1	Front panel test lead.	549-6260-00	Extends AUDIO connectors to test microphone and speaker.
1	Antenna test lead	549-6261-00	Connects to 50-ohm dummy load.
1	RG-58/U coaxial cable 3 ft. long	553-9759-002	Connects antenna simulator to 50-ohm dummy load.
1	RG-58/U coaxial cable 5 ft. long	553-9760-002	Connects antenna simulator to test equipment.
1	Adapter, BNC to Type N coax	357-9291-00	Transition fitting between RG-58/U and dummy load.
1	Antenna simulator	553-9758-005	Simulates 15-foot whip antenna when connected to 50-ohm load. 12 position switch selects operating frequency.
1	Canvas carrying case	553-9764-003	Bag to store and transport Cable Assembly Set An/PRA-4.

Section II. DIRECT SUPPORT TROUBLESHOOTING

3-3. Overall

a. General. When a malfunction of the radio set occurs, the first step in correcting the deficiency is to sectionalize the cause to a specific functional area in the equipment. The tests at operational and organizational-level have undoubtedly isolated the malfunction to circuits within Radio Receiver-Transmitter RT-671/PRC-47. The sectionalizing tests listed below are arranged in an order of increasing circuit complexity and mechanical disassembly requirements within four major functional areas of the radio set. These areas contain the power supply, frequency generation, receiver-transmitter, and relay circuits. When performed in the order listed, these tests provide the maintenance technician with an orderly approach to the isolation of defective circuits and modules within the interrelated transceiver subassembly. Test jacks are installed in the top of each module that permit connection of test instruments to these circuits so that evaluation can be made of the signals and voltage levels. Similar test points and jacks are accessible from the bottom of the main chassis that permit connection of test instruments to the power amplifier and selected primary power circuits.

b. Use of Charts. The voltage and resistance charts and the waveform diagrams shown in this section provide the maintenance technician with a go/no-go criteria that will assist him in locating the circuit deficiency and permit him to restore the circuit parameters to values within the tolerances specified. Before proceeding to any chart, the technician must establish the conditions for the test that are indicated, must perform the initial equipment connections, and establish the radio set operating conditions called for in the procedure. Using this approach, the technician may enter the chart at any functional area and proceed through only that portion of the procedures that are required to correct the deficiency.

(4) Short Circuit Test.

Point of measurement	Normal indication	Isolating procedure
Between A5J1 (fig. 3-4, 3-111 and chassis ground,	40.000 ohms	(Will depend on setting of A5R4). Very low reading, improper adjustment of A5R4 or short at driver grid (A3C293). High reading may indicate A5R4 open.
Between A5J2 and chassis ground.	50,000 ohms	(Will depend on setting of A5R3). Very low reading, shorted feedthru C26 or inductor L122 in pa compartment. defective XMTR PWR switch or shorted plate bypass C123. High reading may indicate A5R3). open.
Between A5J3 and chassis ground.	10 ohms	Very low reading: shorted C208, C221, or C235 in FL2. shorted primary at T3, or short in filament bypass C104. High reading may indicate open winding at T1, defective tube V101, or open hum balance control R121.

3-4. Troubleshooting Radio Receiver-Transmitter RT-671/PRC-47 (A8)

CAUTION

Do not apply power to the receiver-transmitter unless operational trouble symptoms are known and are of such a nature as to eliminate the possibility of further damage when the power is applied.

a. Testing for Shorts.

(1) When to Check. When any of the following conditions apply, check for short circuits and repair any existing deficiency before applying power to the receiver-transmitter.

(a) When the receiver-transmitter is being serviced and the fault symptoms are unknown.

(b) When an inspection of fuses F1 through F5 shows that a fuse has blown.

(2) Conditions for Tests.

(a) Disconnect all cables from the front panel of the receiver-transmitter.

(b) Remove the dust cover from the receiver-transmitter using the procedure of paragraph 3-11.

(3) Measurements. Using the multimeter, make the resistance measurements shown in the chart below. Unless otherwise indicated in the point of measurement column of this chart, all resistance measurements are made from the test point shown to chassis ground. The normal indication shown is an average value and may vary from one unit to another and from one multimeter to another. Any reading that disagrees widely from the value shown will cause the maintenance technician to proceed to the isolating procedure indicated. Location of a defective part must initiate the repair procedure shown in section IV.

Point of measurement	Normal indication	Isolating procedure
Between A5J4 and chassis ground.	15 ohms	Very low reading, shorted C207, C220, or C234 in FL2, shorted primary of T3, or short in filament bypass C103, or defective ac power control relay K2. High reading may indicate open winding at T1.
Between A5J7 and chassis ground.	15 ohms	Very low reading, shorted filter capacitor C25, C26, C28, or C29, shorted R14 or defective voltage regulator assembly TB1. High reading may indicate open inductor L1.
Between A5J8 and chassis ground.	30 ohms	Very low reading, shorted filter capacitor C27, transistor Q3, or short in other modules. High reading defective voltage regulator assembly TB1.
Between A5J9 and chassis ground.	8 ohms	Very low reading, shorted filter capacitor C25, C26, C28, or C29, shorted R14 or defective low-voltage rectifier CR26 through CR29. High reading, open inductor L1.
Between A5J10 and chassis ground	Infinity	A low reading may indicate a short on the 115-volt, 400-Hz primary power source..
Between A5J11 and chassis ground	Infinity	A low reading may indicate a short on the 115-volt, 500-Hz primary power source.
Between A6J2 and chassis ground.	200 ohms	A low reading: shorted filter capacitor A6C37, A6C36, bypass capacitors A7C4, A7C9, A7C20, A2C19. High reading may indicate open inductor A6L9.

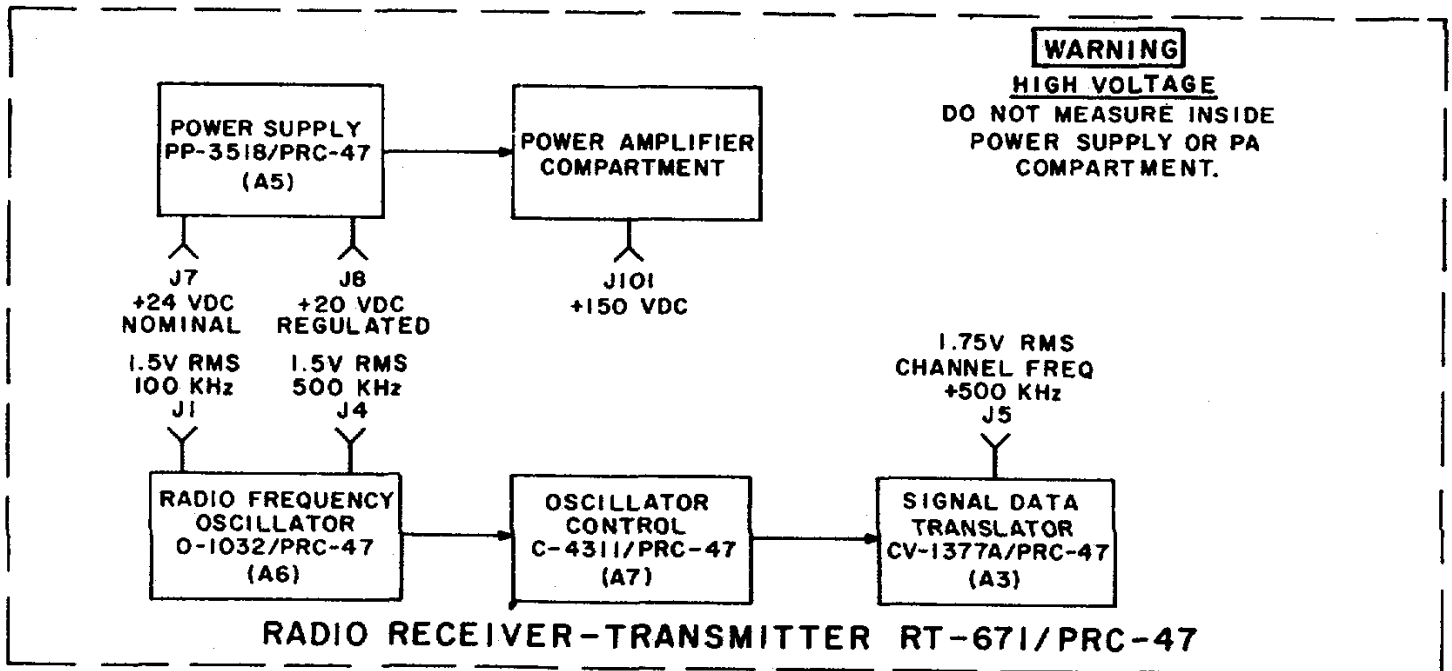

NOTE:
USE ME-30/U FOR MEASUREMENTS.

TM5820-509-35-16

Figure 3-1. Preliminary Troubleshooting Diagram.

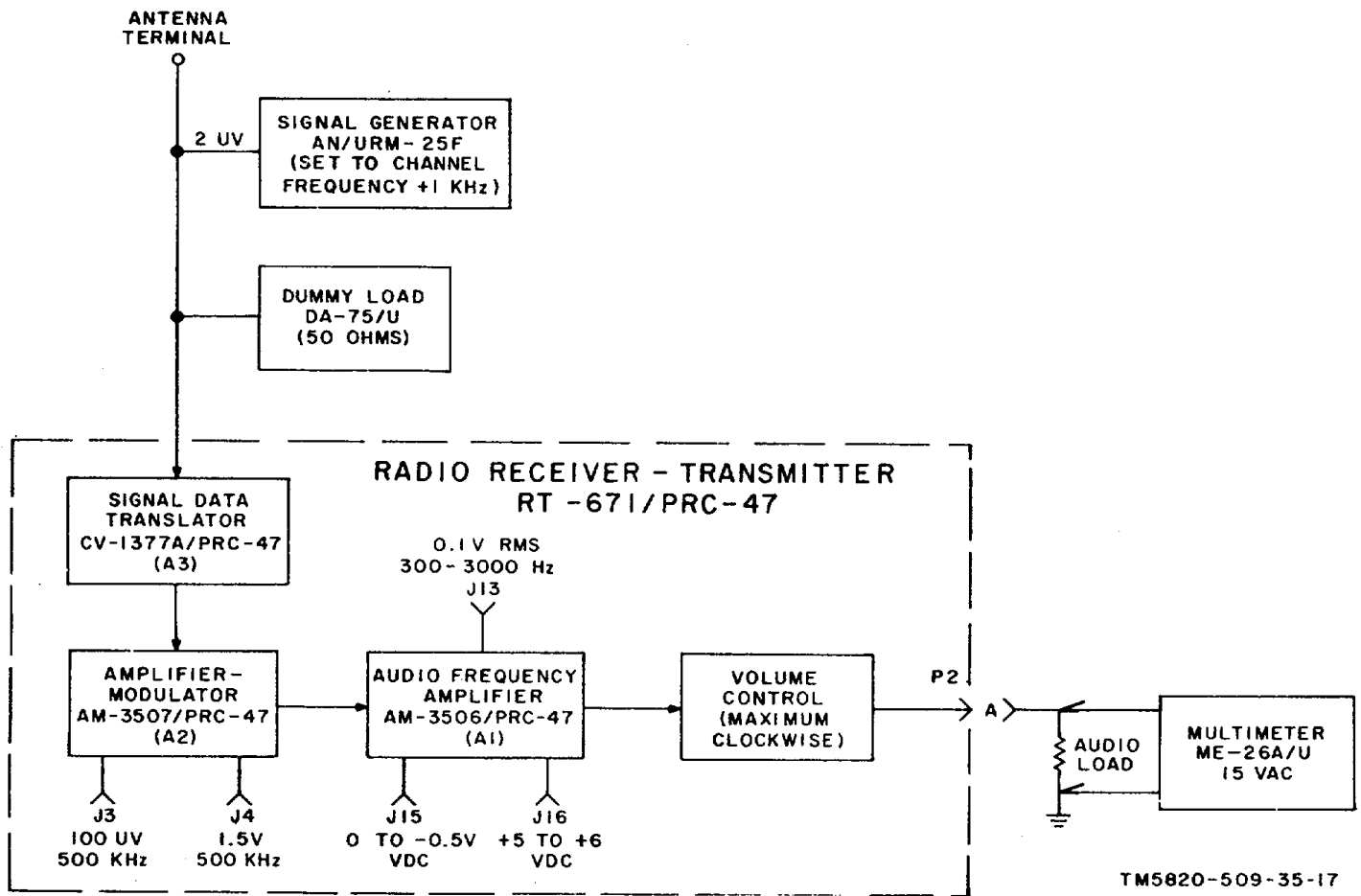

TM5820-509-35-17

Figure 3-2. Receiver Tests, Troubleshooting Test Setup.

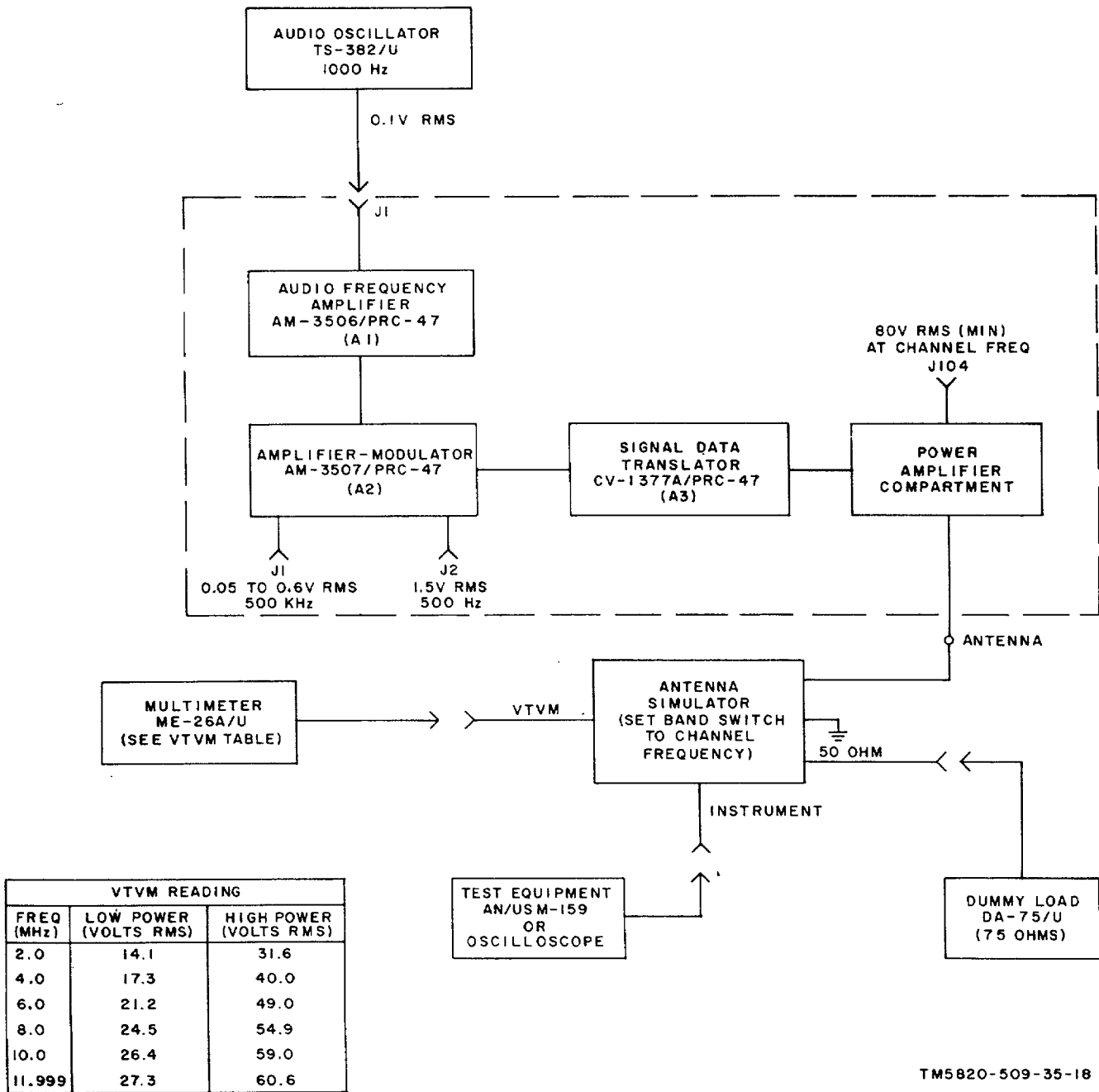

TM 5820-509-35-18

Figure 3-3. Transmitter Tests, Troubleshooting Test Setup.

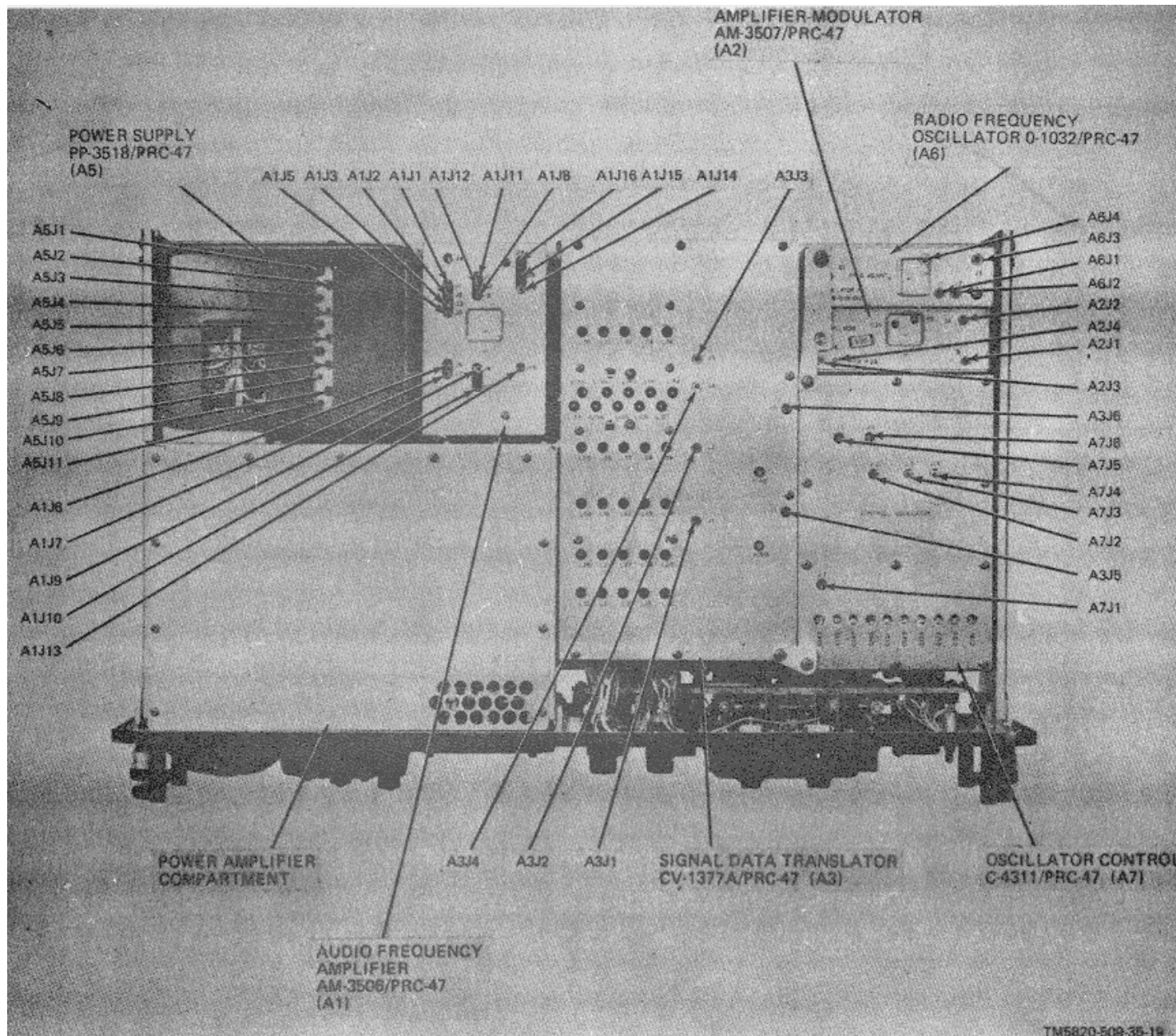

Figure 3-4. Radio Receiver-Transmitter RT-671/PRC-47 (A8), Top View, Location of Assemblies and Test Points.

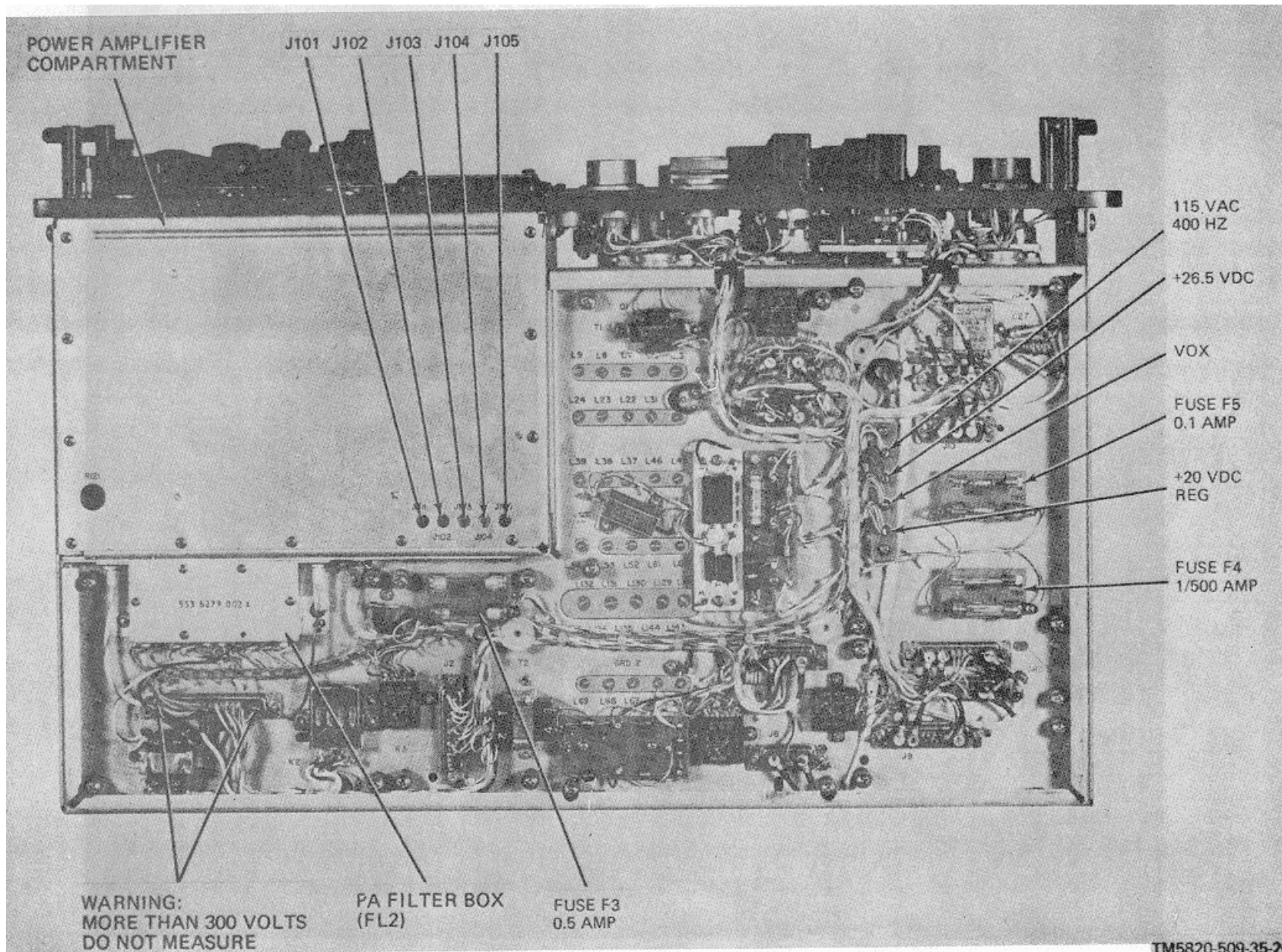
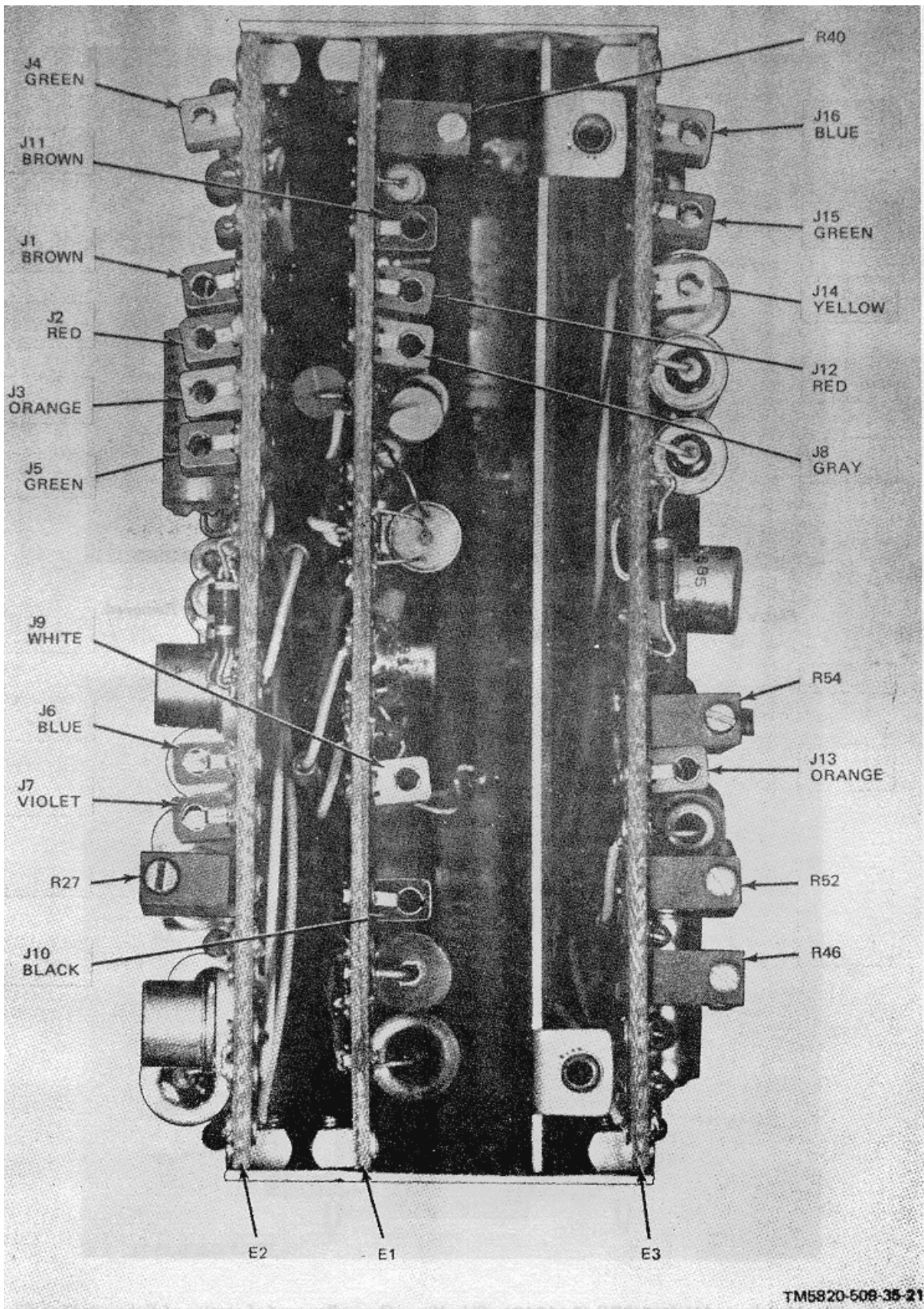

Figure 3-5. Radio Receiver-Transmitter RT-671/PRC-47 (A8), Bottom View, Location of Assemblies and Test Points.



TM5820-509-35-21

Figure 3-6. Audio Frequency Amplifier AM-3506/PRC-47 (A8A1), Top View, Cover Removed, Location of Subassemblies and Test Points..

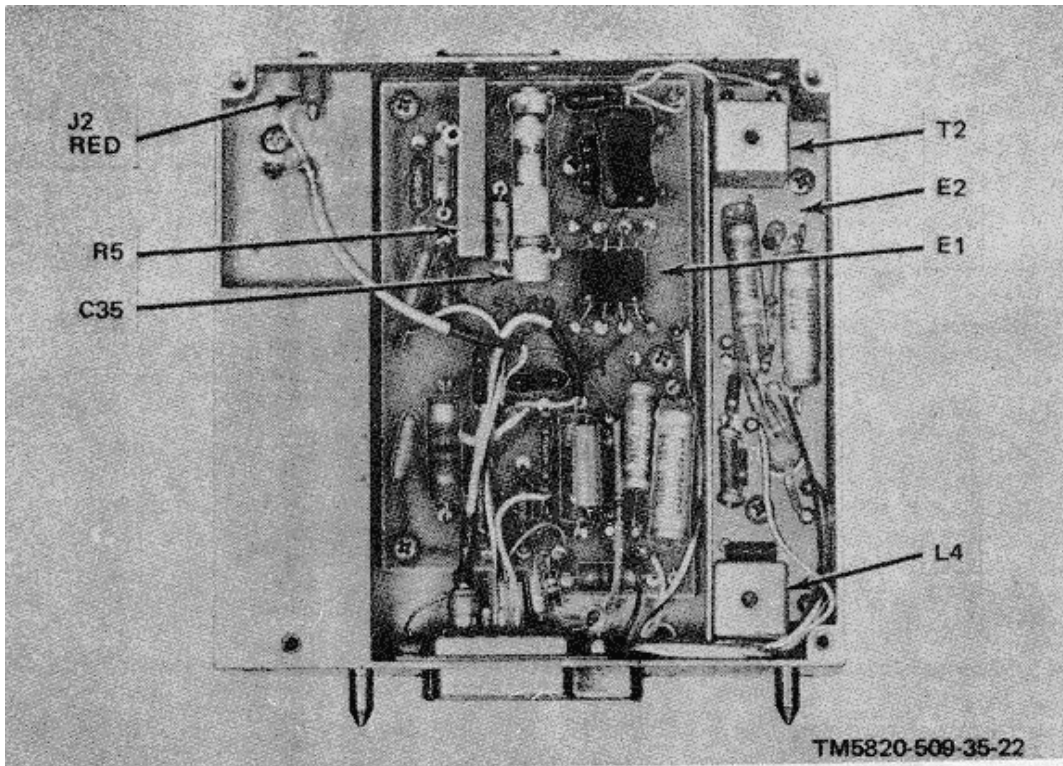

Figure 3-7. Amplifier-Modular AM-3507/PRC-47 (A8A2), Side View, Cover Removed, Location of Subassemblies E1 and E2 and Test Points

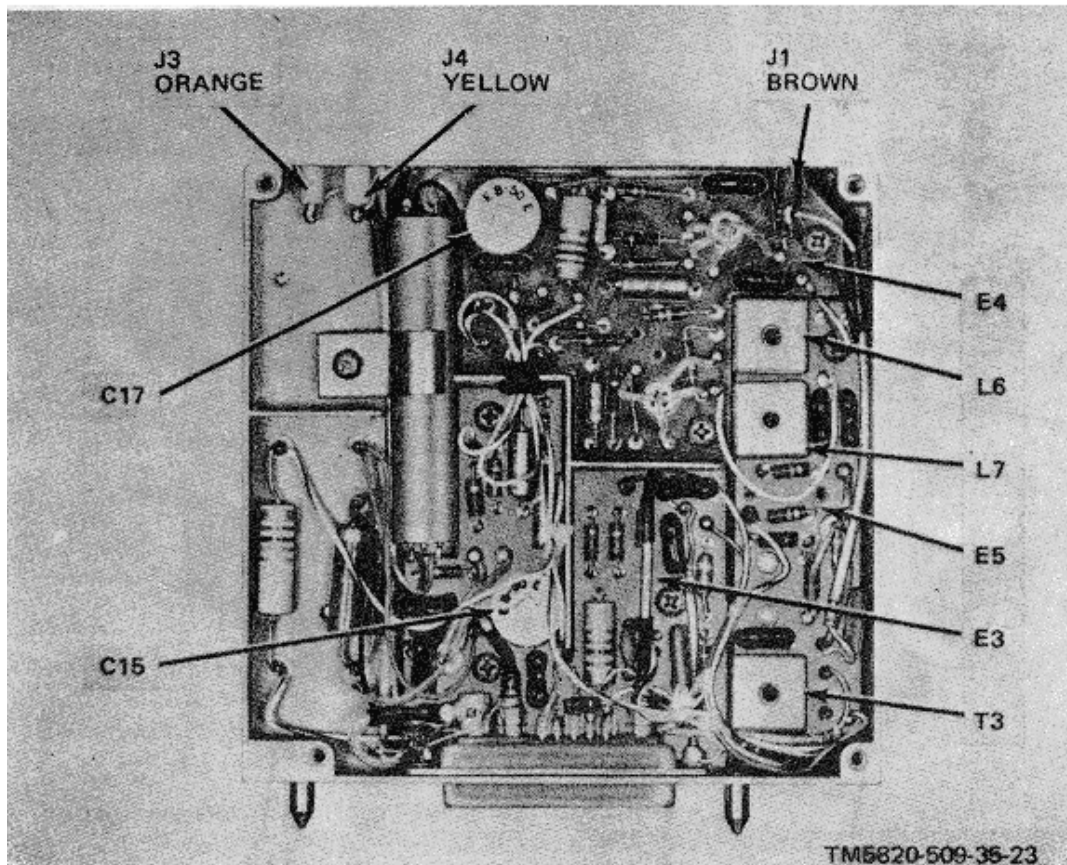

Figure 3-8. Amplifier-Modular AM-3507/PRC-47 (A8A2), Side View, Cover Removed, Location of Subassemblies E3, E4 and E5 and Test Points

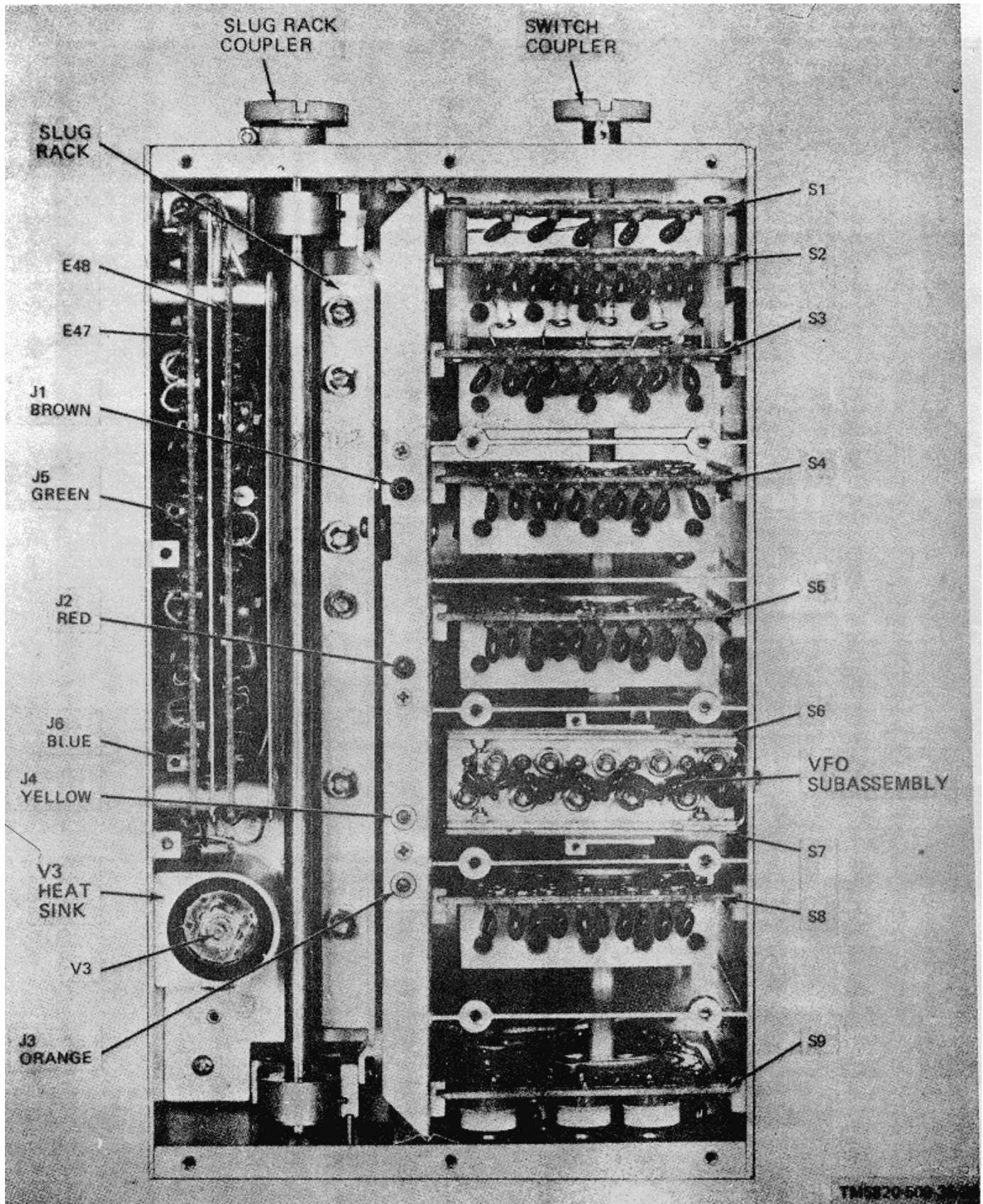

Figure 3-9. Signal Data Translator CV 1377/PRC-47 (A8A3), Top View, Location of Subassemblies and Test Points.

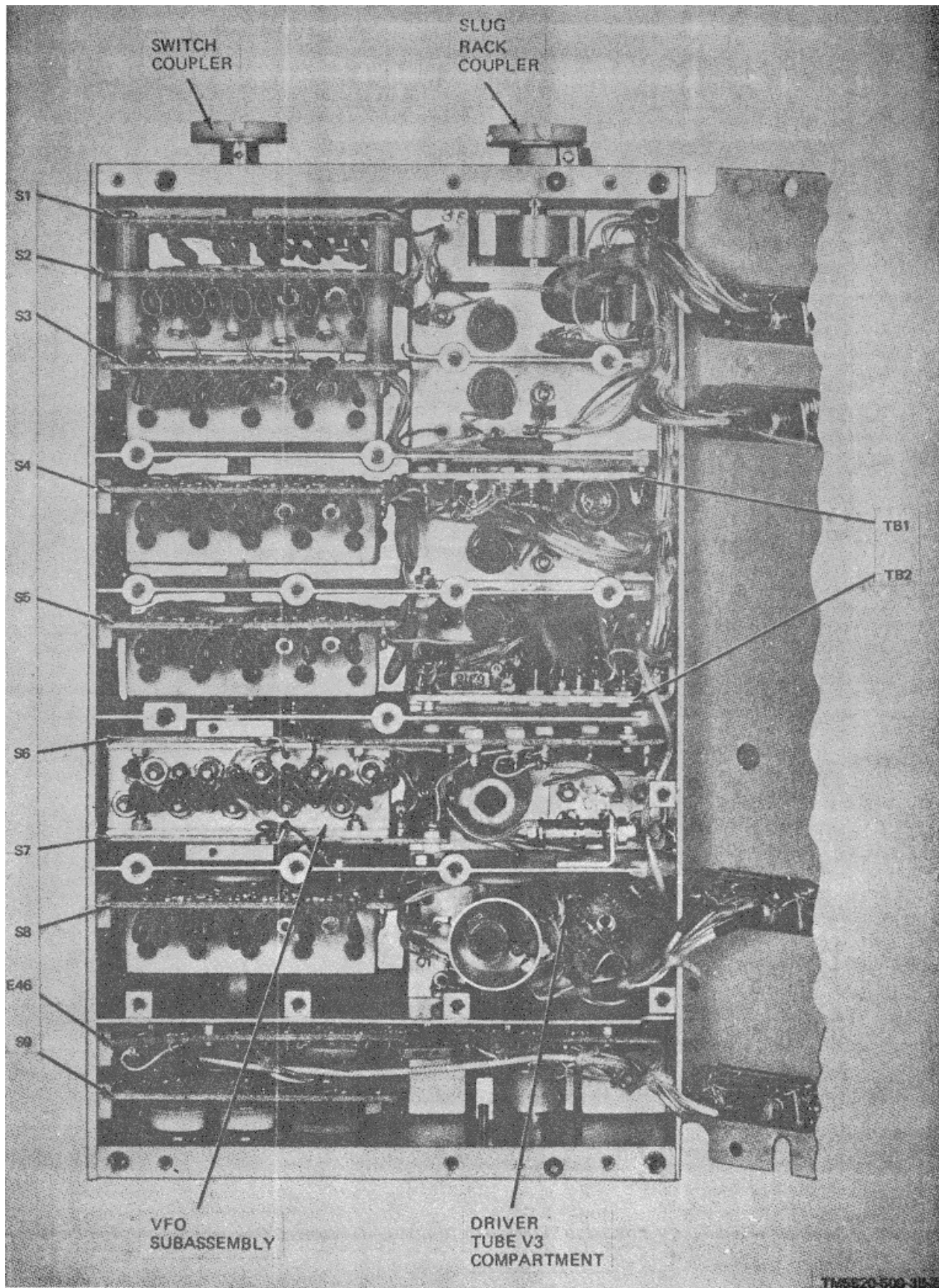

Figure 3-10. Signal Data Translator CV-1377A PRC-47 (A8A3), Bottom View, Location of Subassemblies.

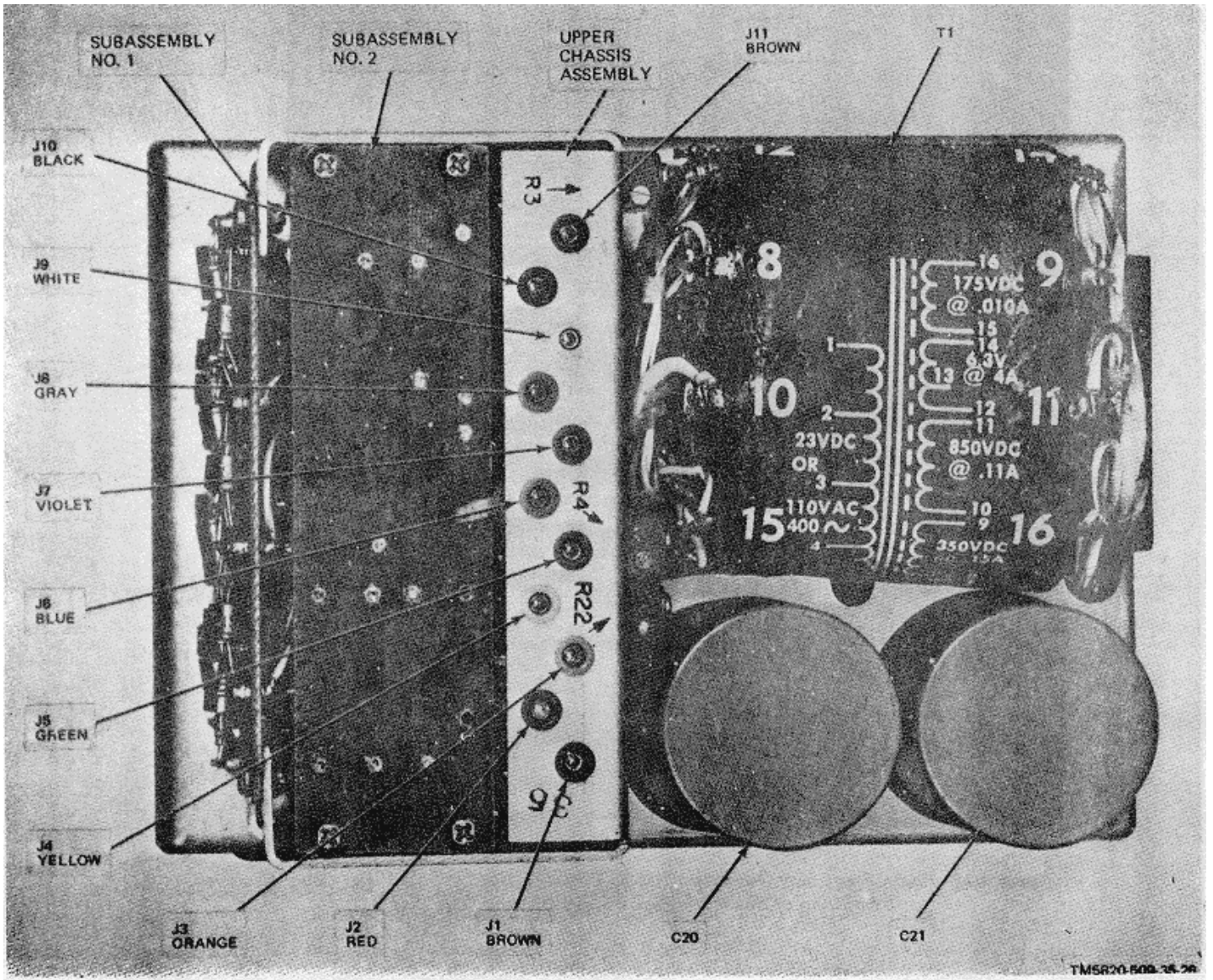

Figure 3-11. Power Supply PP-3518/PRC-47 (A8A5), Top View, Cover Removed, Location of Subassemblies and Test Points.

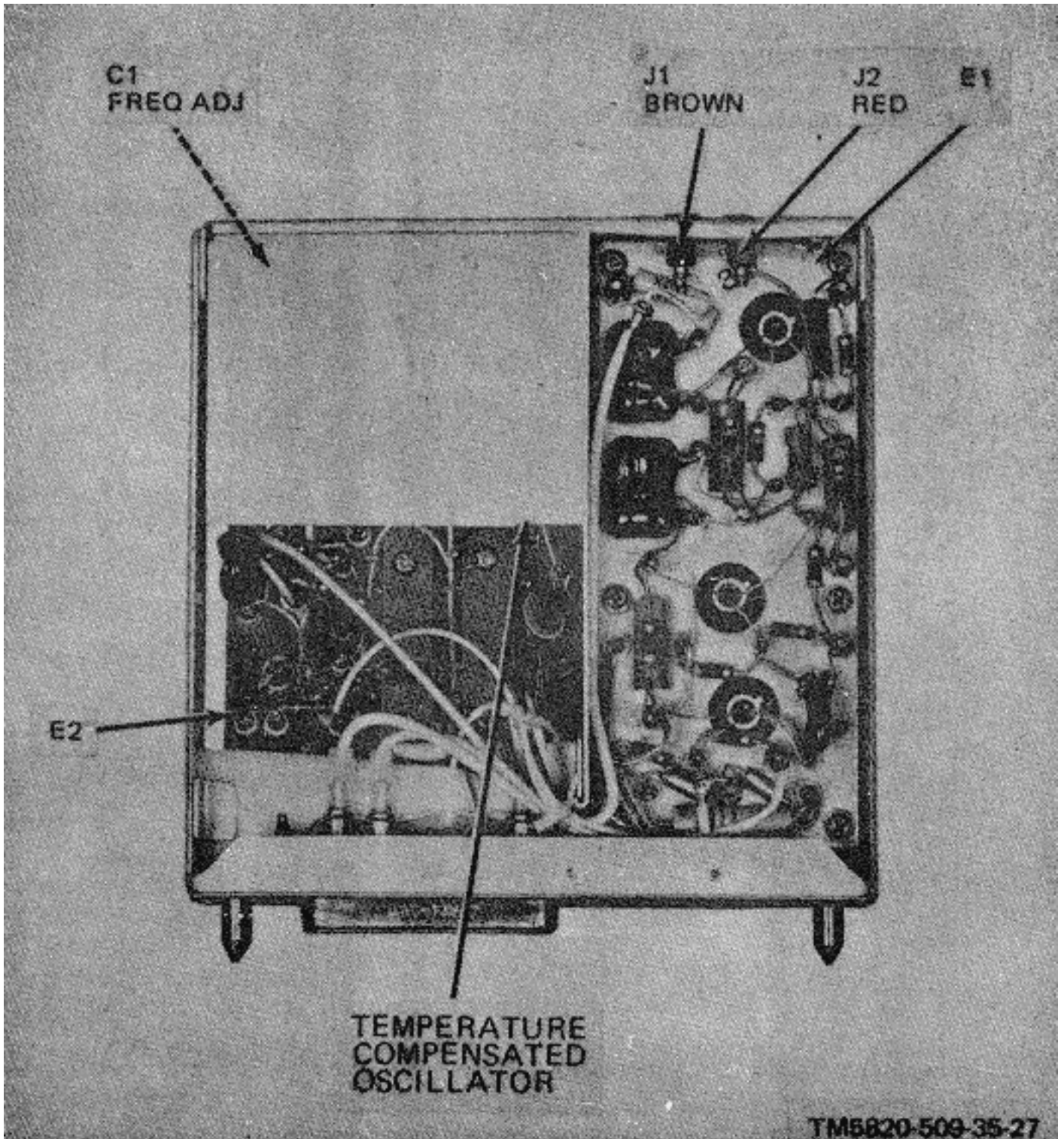

Figure 3-12. Radio Frequency Oscillator O-1032/PRC-47 (A8A6), Side View, Cover Removed, Location of Subassemblies E1 and E2, and Test Points.

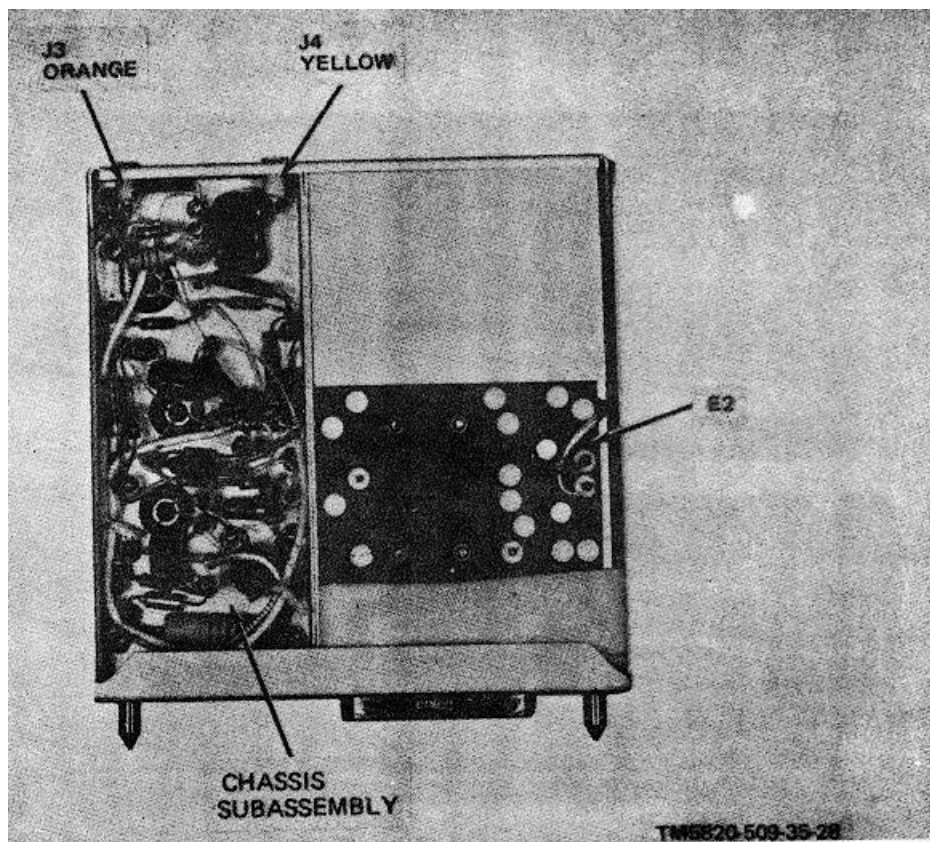

Figure 3-13. Radio Frequency Oscillator O-1032/PRC-47(A8A6), Side View, Cover Removed, Location of Chassis Subassembly and Test Points.

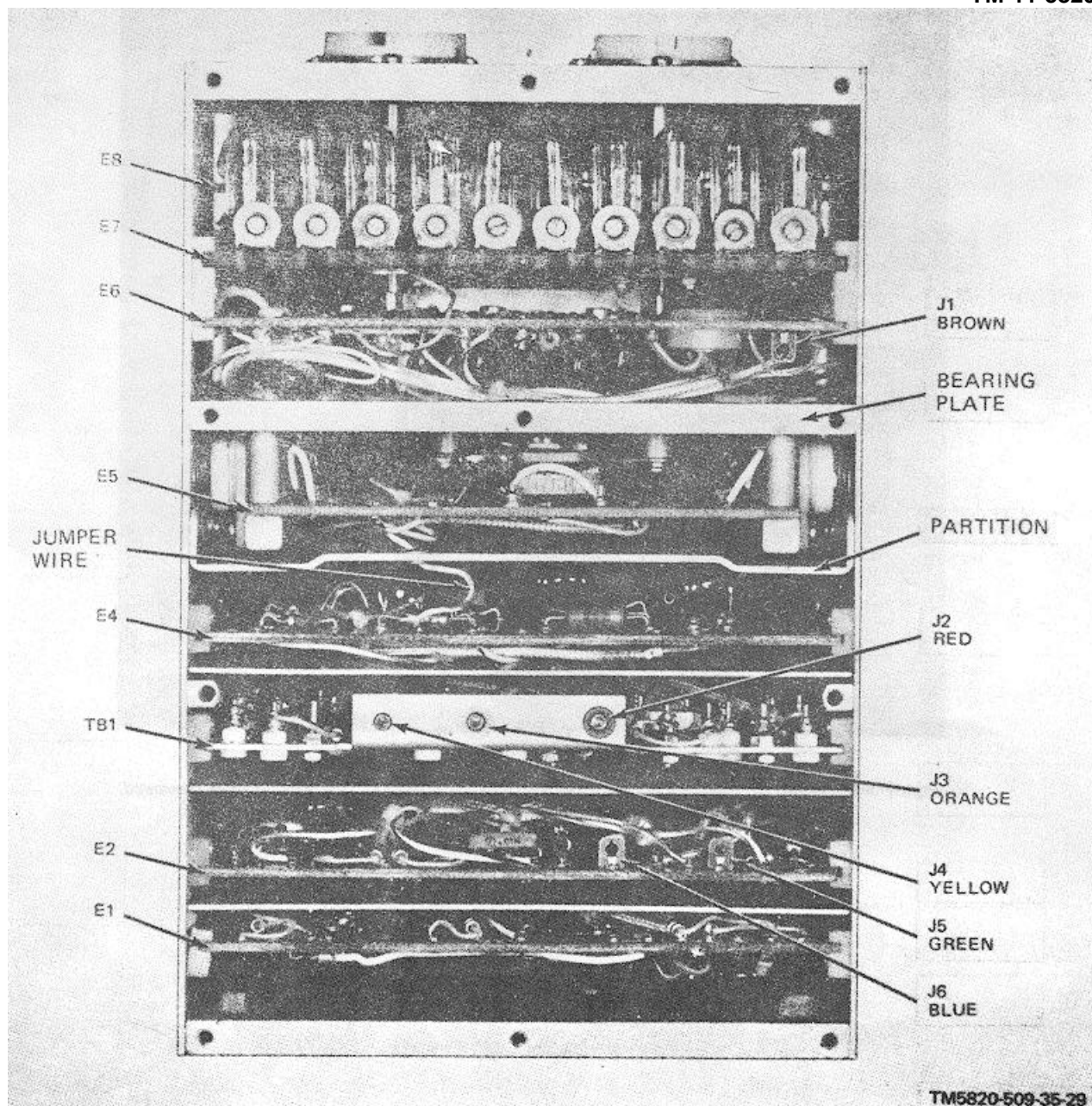

Figure 3-14. Oscillator Control C-4311/PRC-47 (A8A7), Top View, Cover Removed, Location of Subassemblies and Test Points.

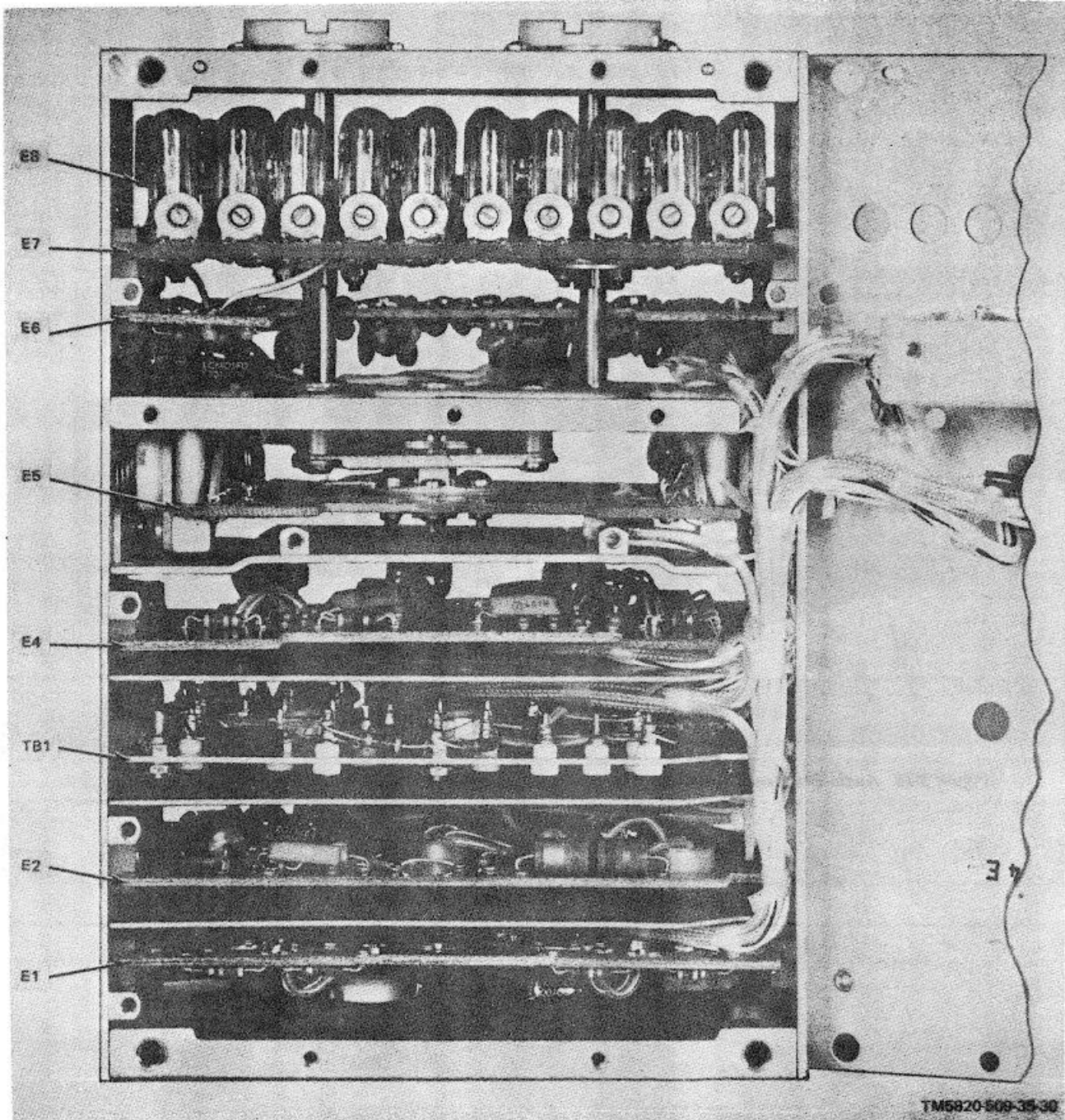

Figure 3-15. Oscillator Control C-4311/PRC-47(A8A7), Bottom View, Location of Subassemblies.
3-17

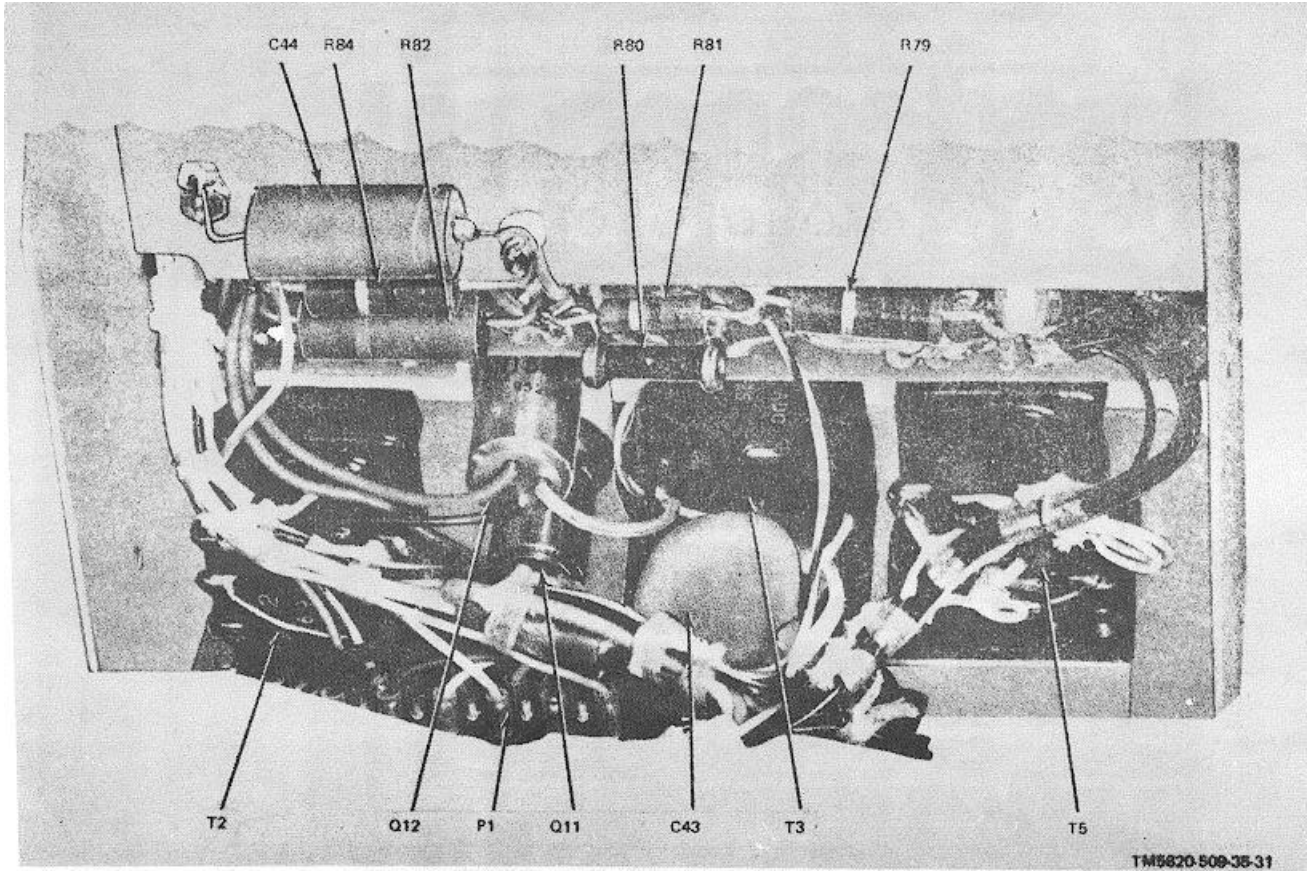

Figure 3-16. Audio Frequency Amplifier AM-3506/PRC-47(A8A1), Cover Removed, Chassis Subassembly.
3-18

TM5820-509-35-31

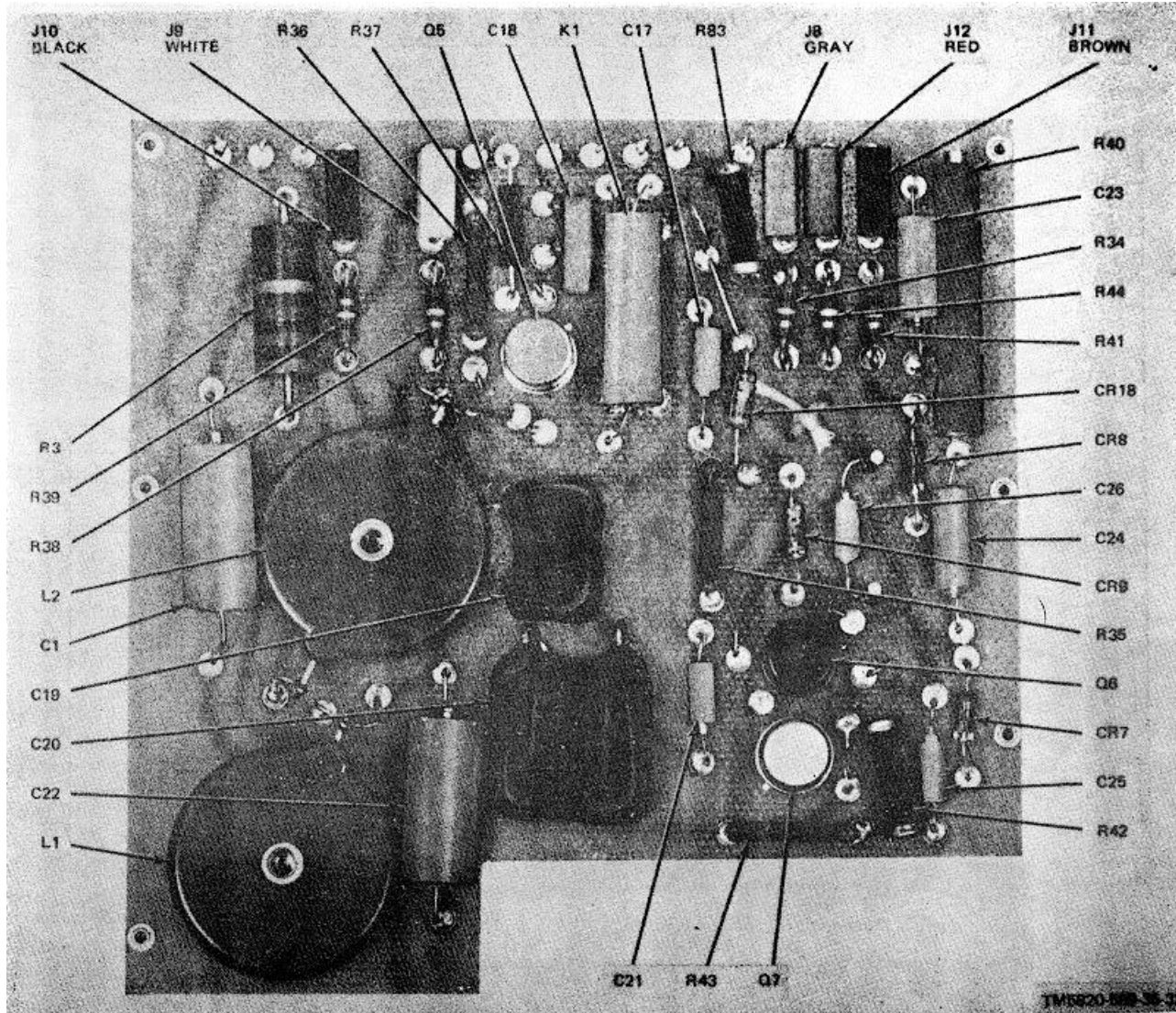

Figure 3-17. Audio Frequency Amplifier AM-3506/PRC-47(A8A1), Cover Removed, Subassembly E1.
3-19

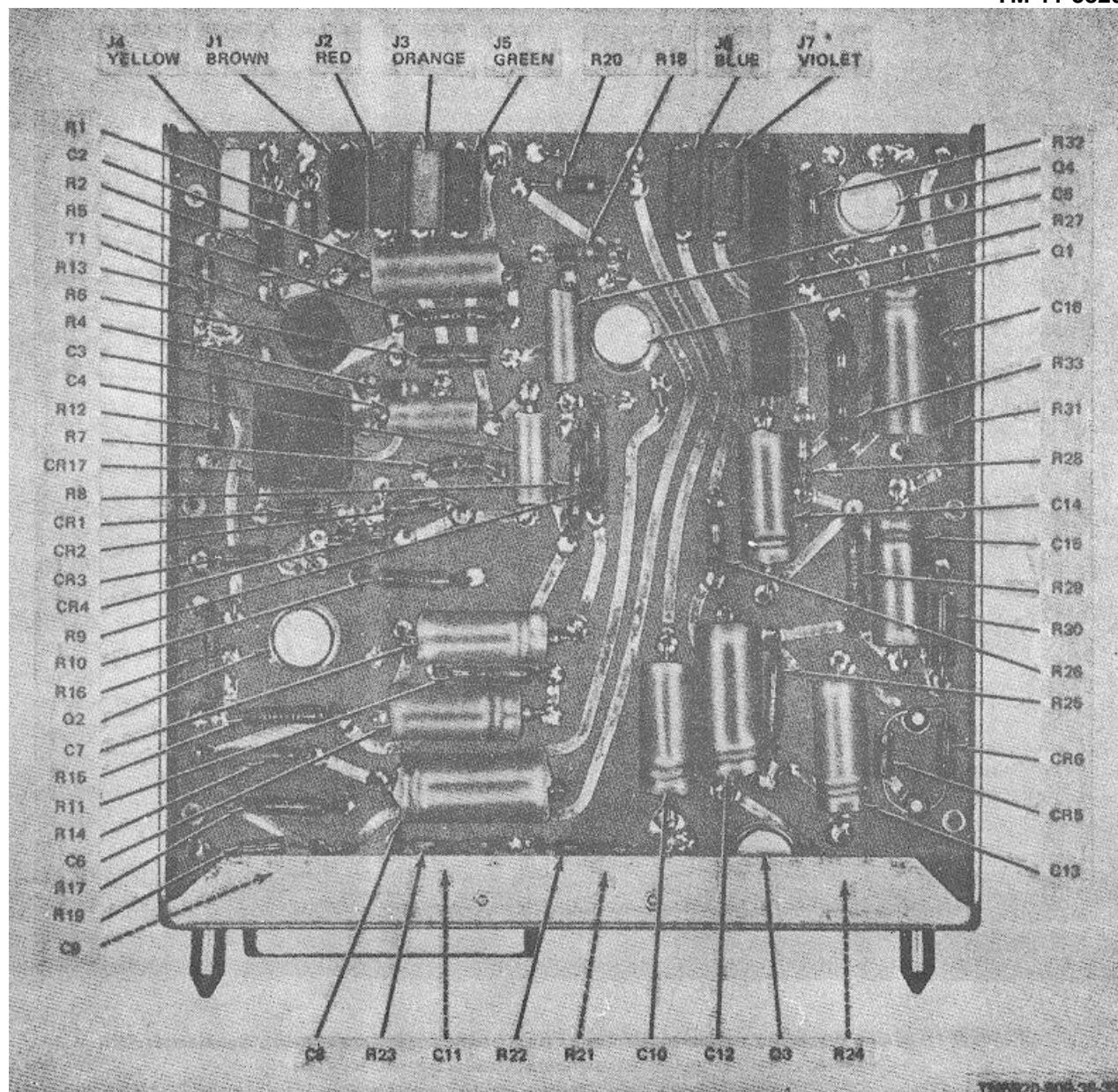

Figure 3-18. Audio Frequency Amplifier AM-3506/PRC-47 (A8A1), Cover Removed, Subassembly E2.
3-20

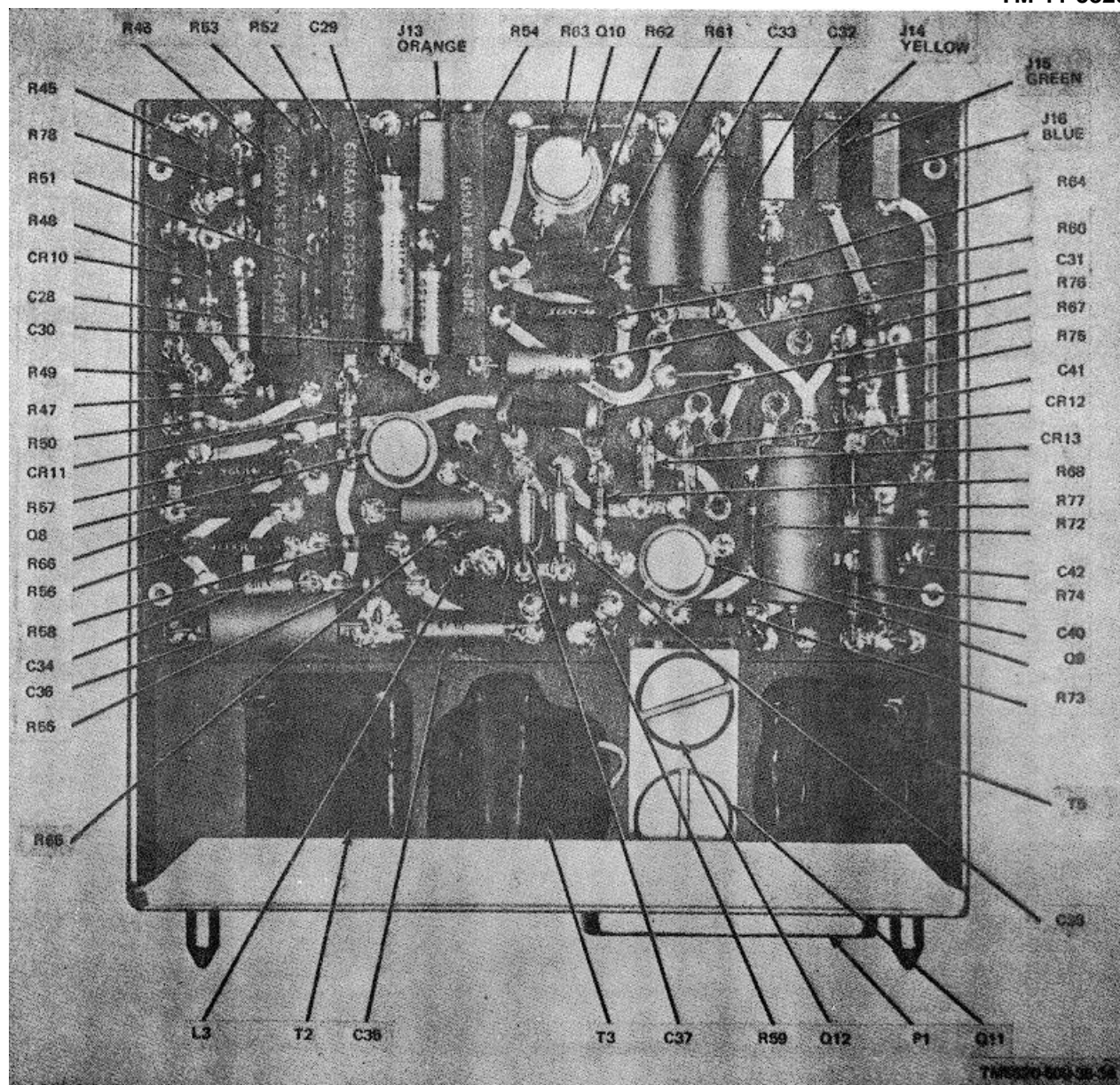

Figure 3-19. Audio Frequency Amplifier AM-3506/PRC-47 (A8A1), Cover Removed, Subassembly E3.
3-21

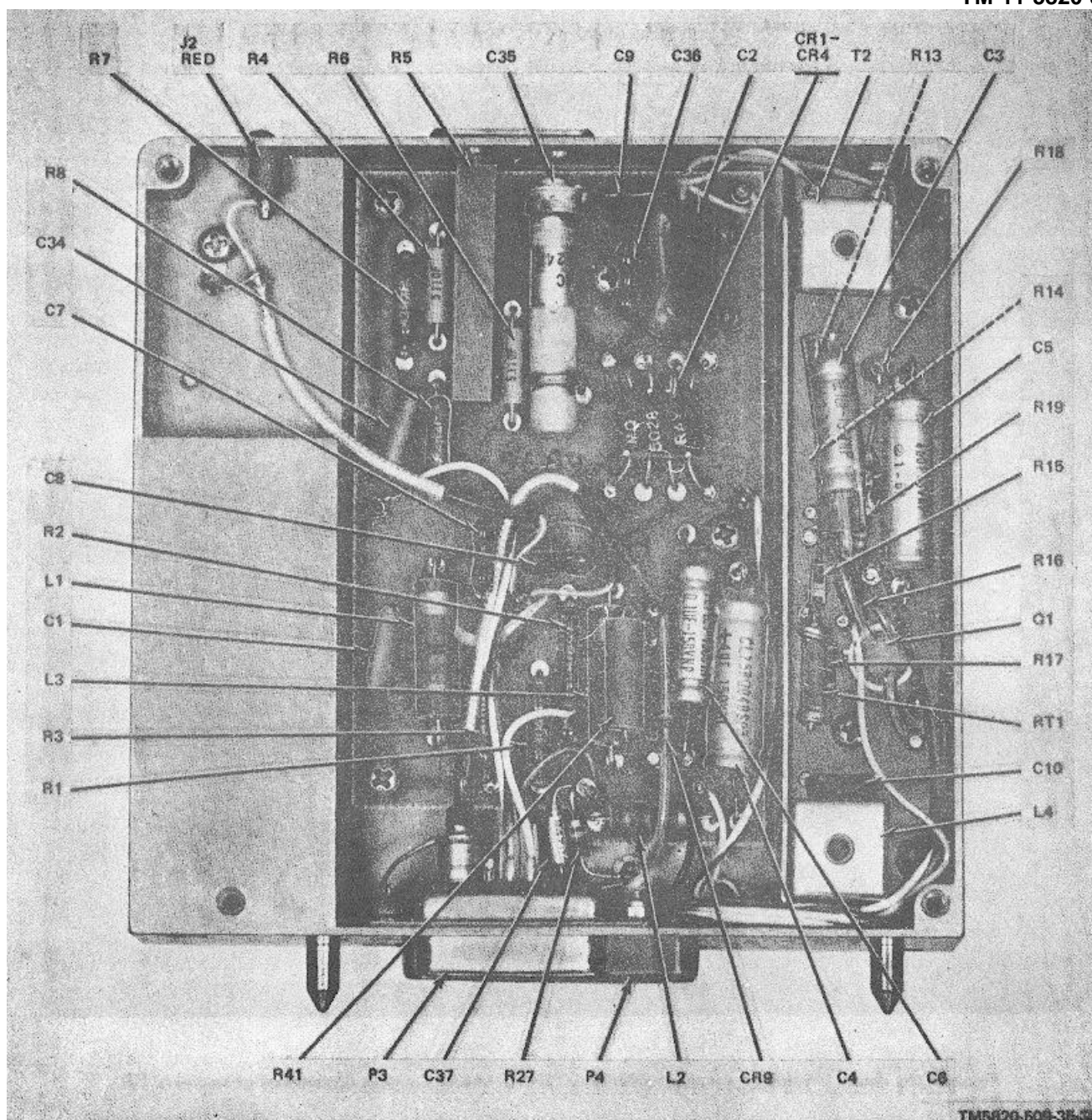

Figure 3-20. Amplifier-Modulator AM-3507/PRC-47(A8A2), Cover Removed, Subassemblies E1 and E2.
3-22

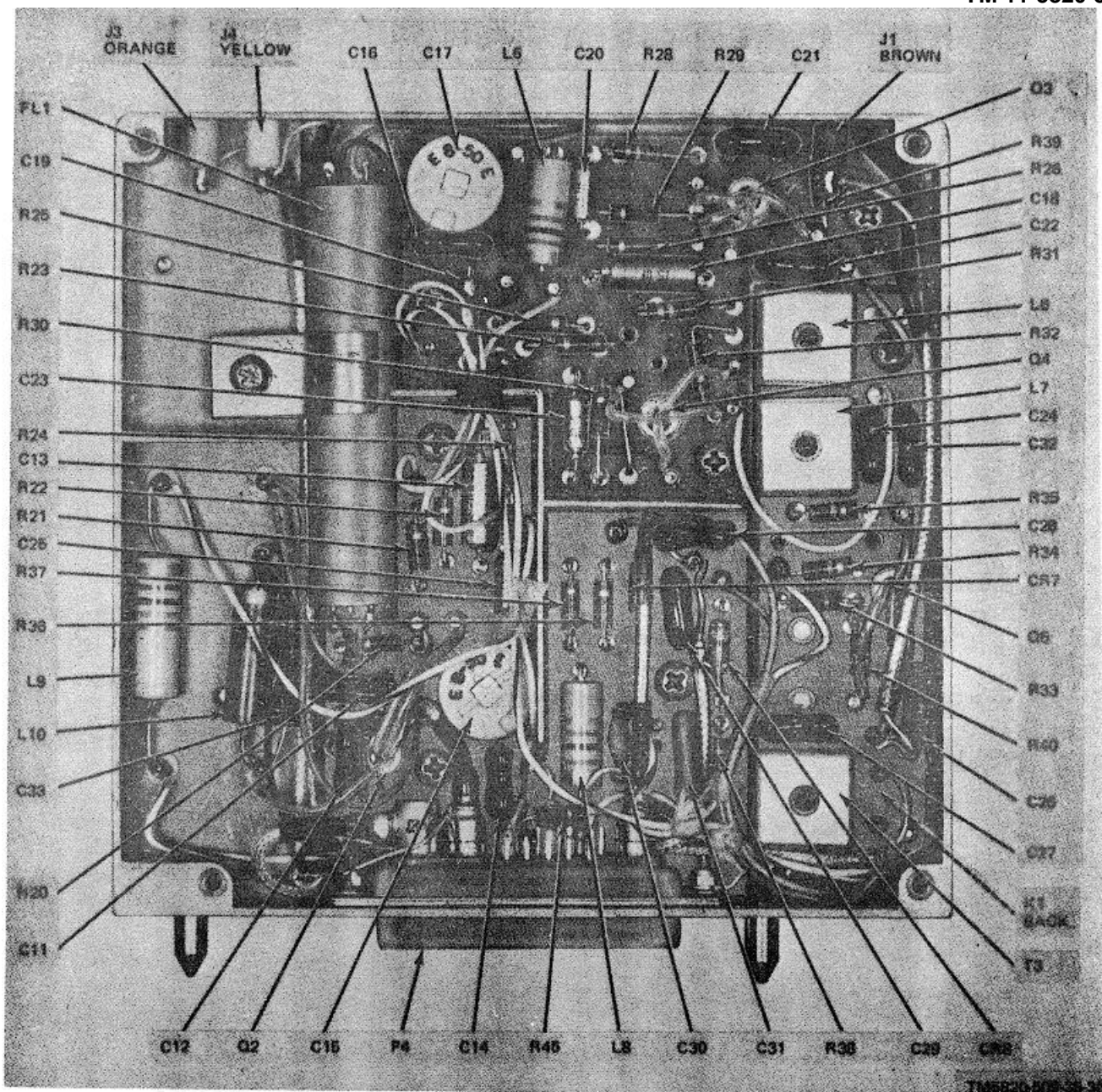

Figure 3-21. Amplifier-Modulator AM-3507/PRC-47 (A8A2), Cover Removed, Subassemblies E3, E4, and E5.

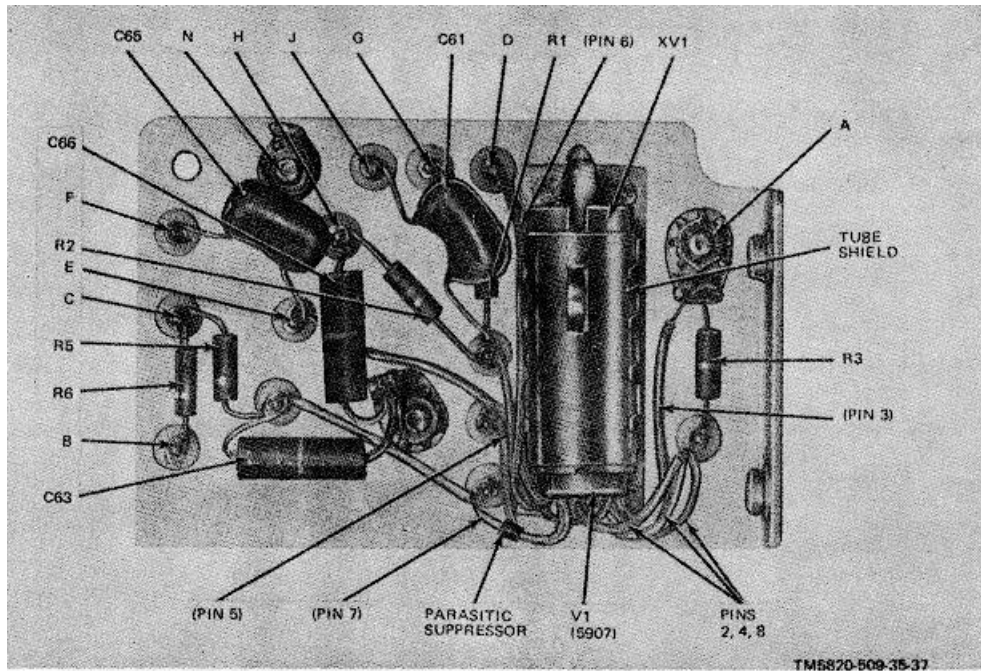

Figure 3-22. Signal Data Translator CV-1377A/PRC-47 (A8A3), Card Assembly TB1.

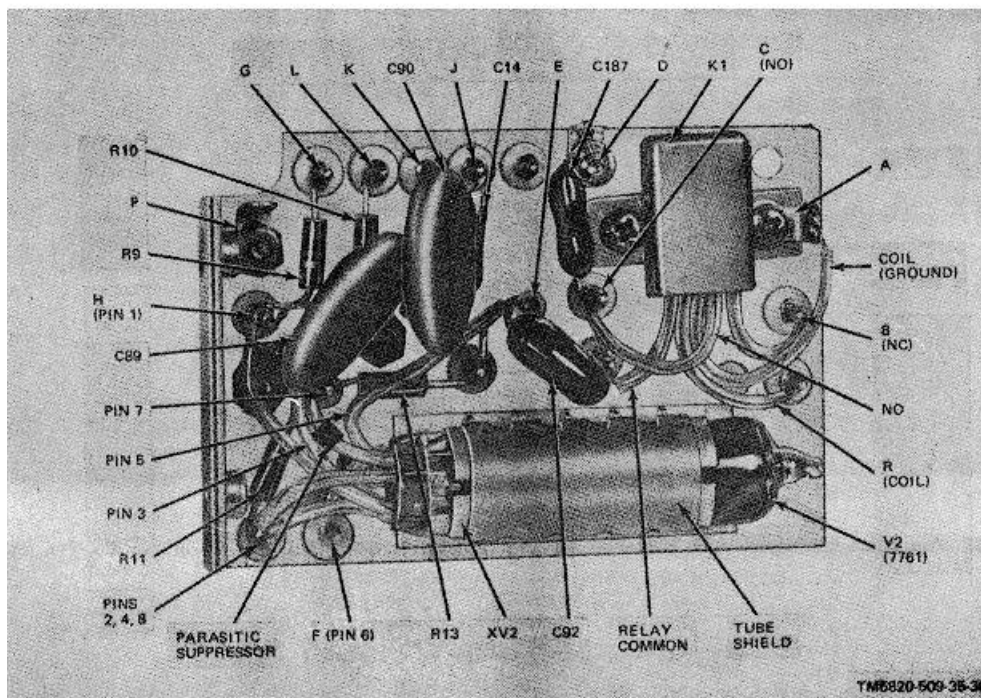

Figure 3-23. Signal Data Translator CV-1377A/PRC-47 (A8A3), Card Assembly TB2.

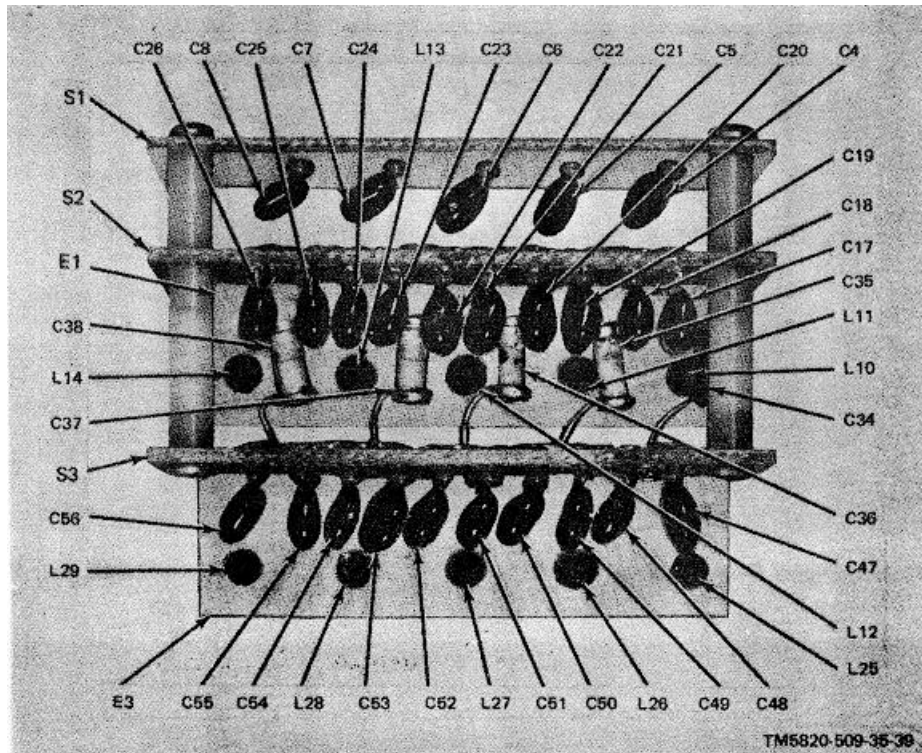

Figure 3-24. Signal Data Translator CV-1377A/PRC-47 (A8A3), Switch Assemblies S1, S2, and S3, Top View, Card Assemblies E1 and E3.

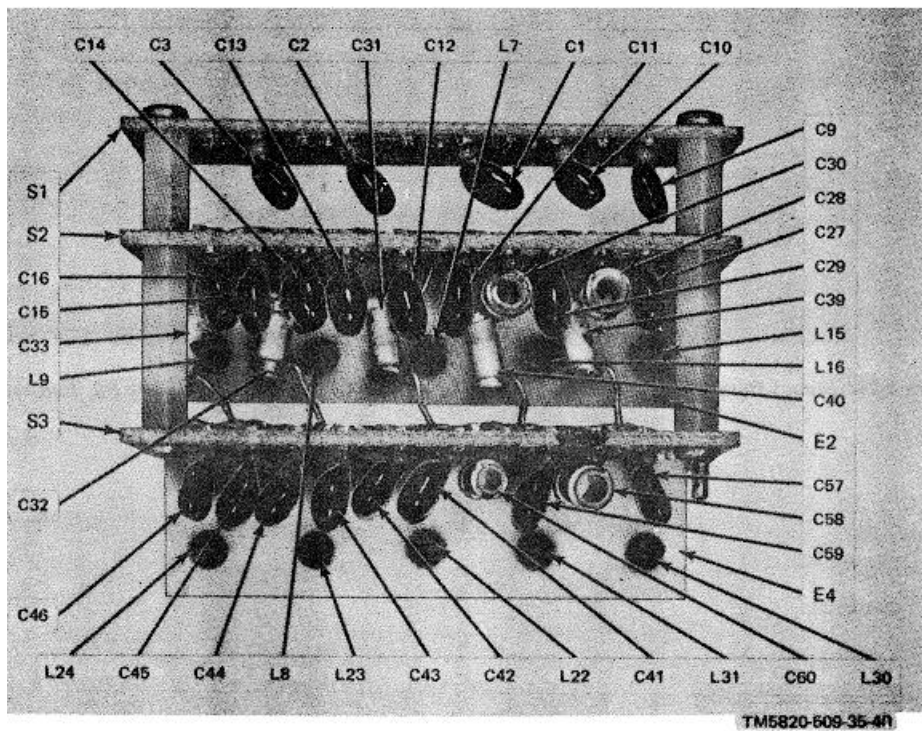

Figure 3-25. Signal Data Translator CV-1377A/PRC-47 (A8A4), Switch Assemblies S1, S2, and S3, Bottom View, Card Assemblies E2 and E4.

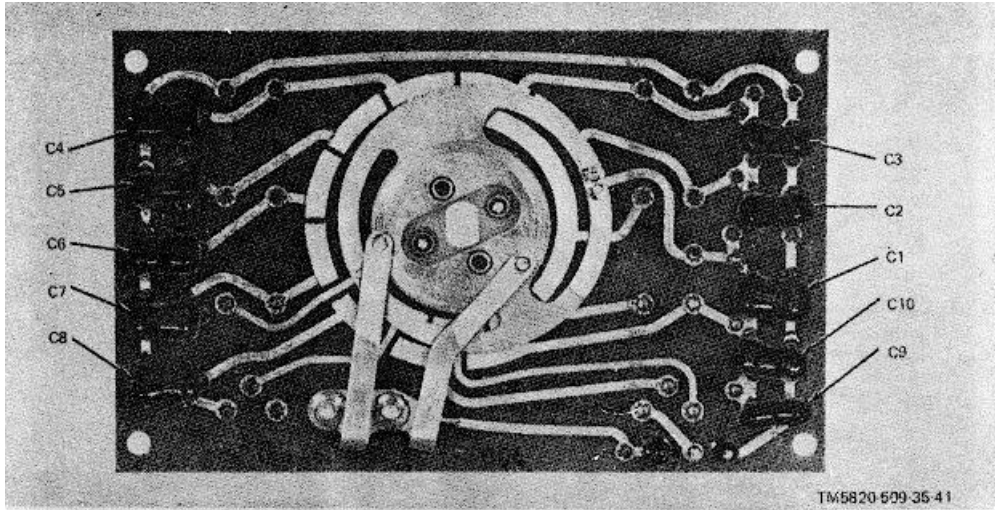

Figure 3-26. Signal Data Translator CV-1377A/PRC-47 (A8A3), Switch Assembly S1, Rear View.

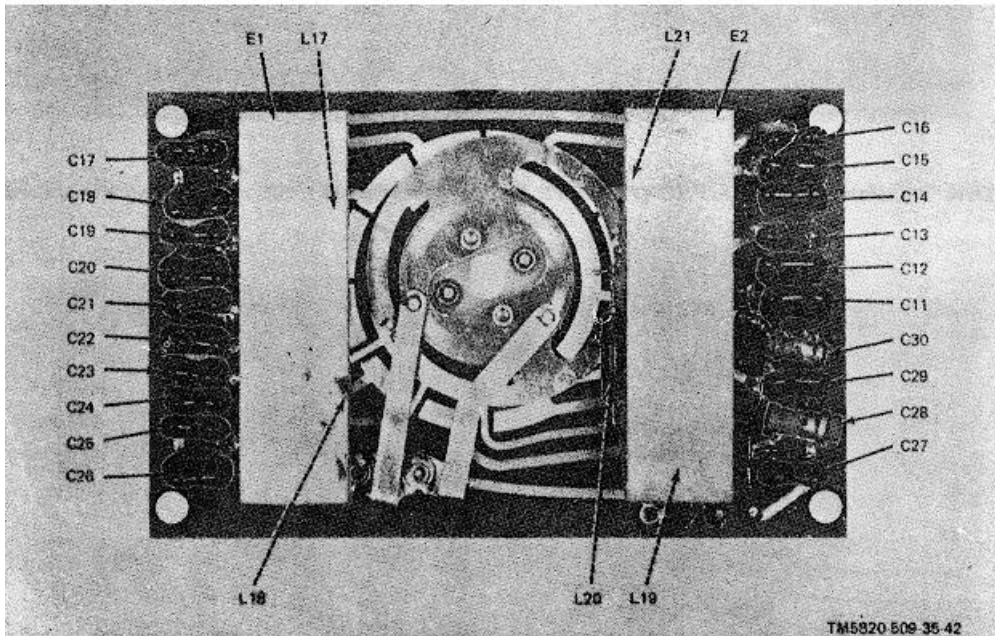

Figure 3-27. Switch Data Translator CV-1377A/PRC-47 (A8A3), Switch Assembly S2, Rear View.

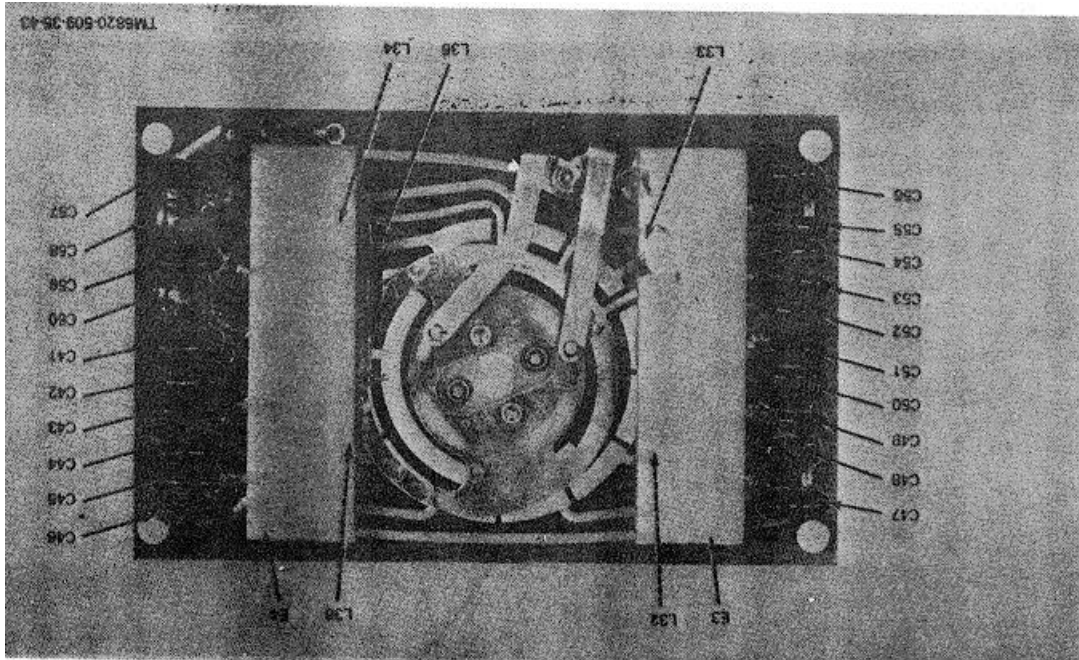

Figure 3-28. Signal Data Translator CV-1377A/PRC-47 (A8A3), Switch Assembly S3, Rear View.

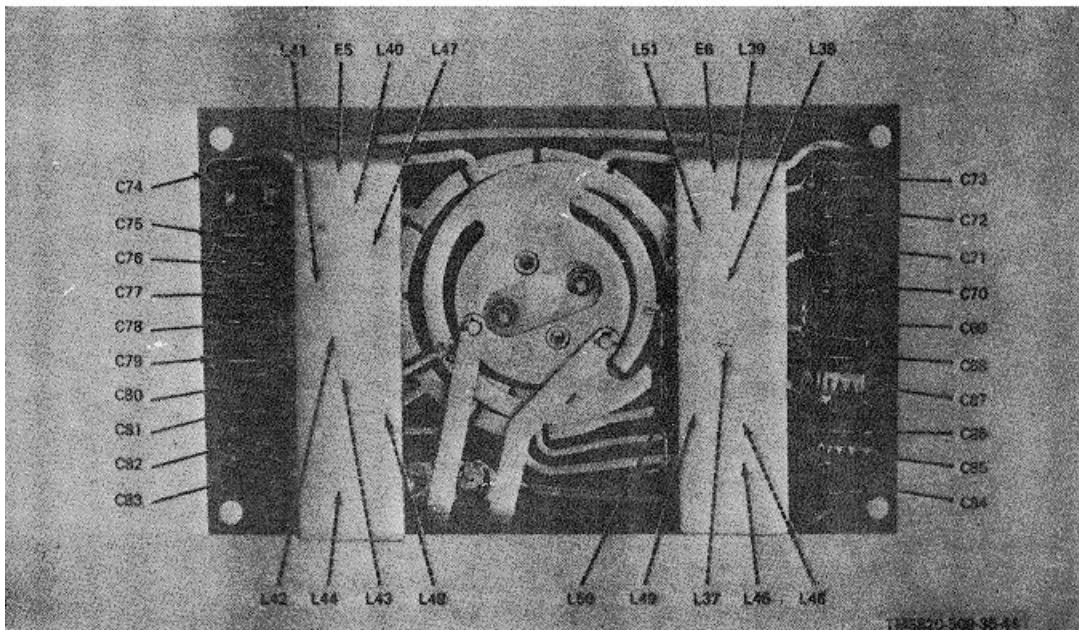

Figure 3-29. Signal Data Translator CV-1377A/PRC-47 (A8A3), Switch Assembly S4, Rear View.

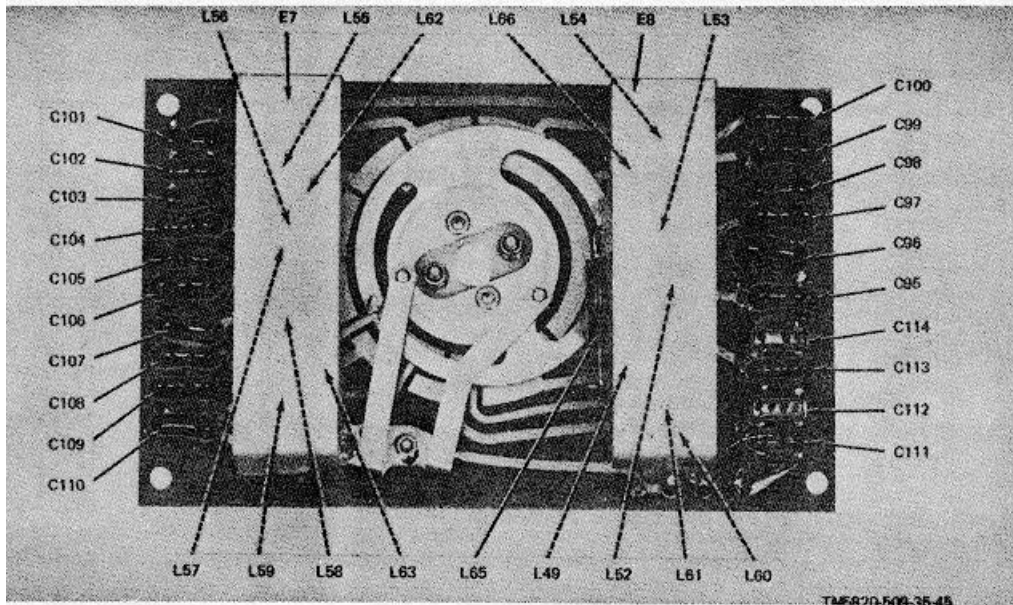

Figure 3-30. Signal Data Translator CV-1377A/PRC-47 (A8A3), Switch Assembly S5, Rear View.

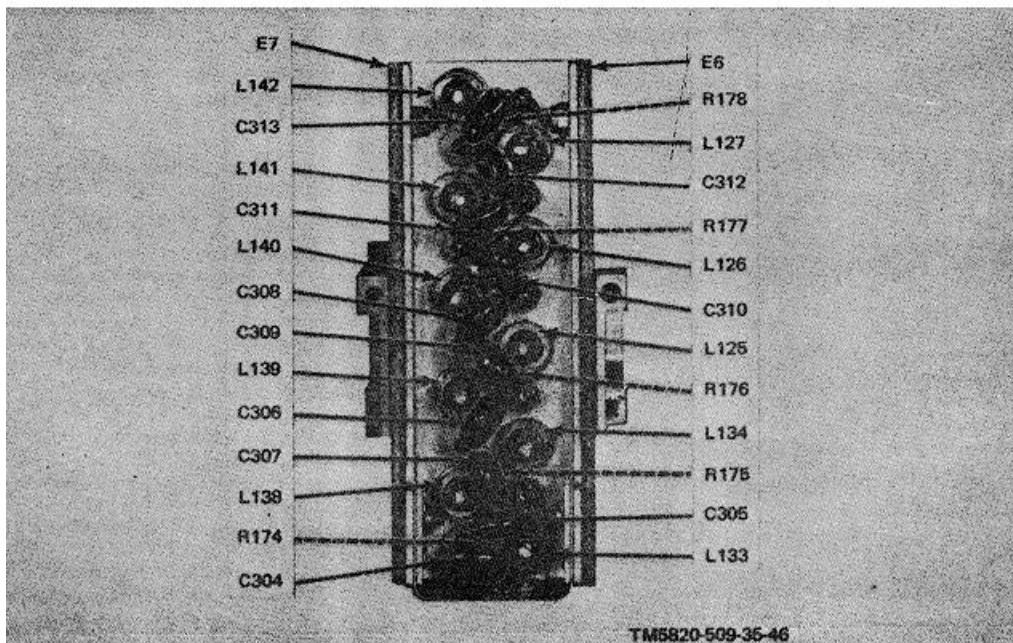

Figure 3-31. Signal Data Translator CV-1377A/PRC-47 (A8A3), VFO Coil subassembly, Top View.

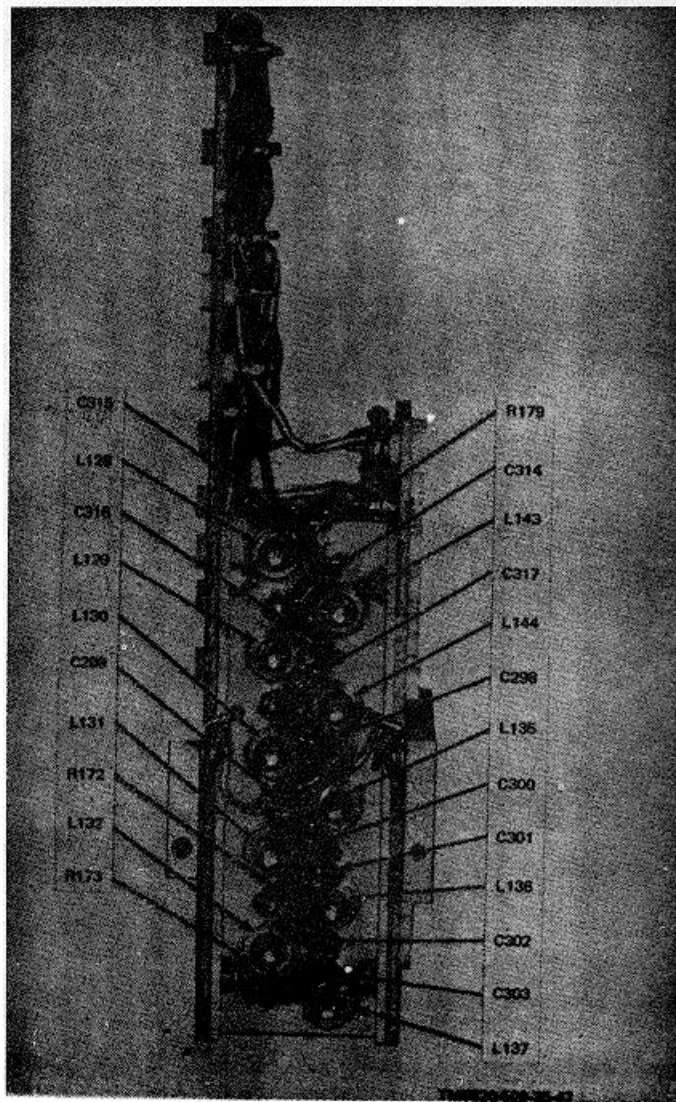

Figure 3-32. Signal Data Translator CV-1377A/PRC-47 (A8A3), VFO, Coil Subassembly, Bottom View.

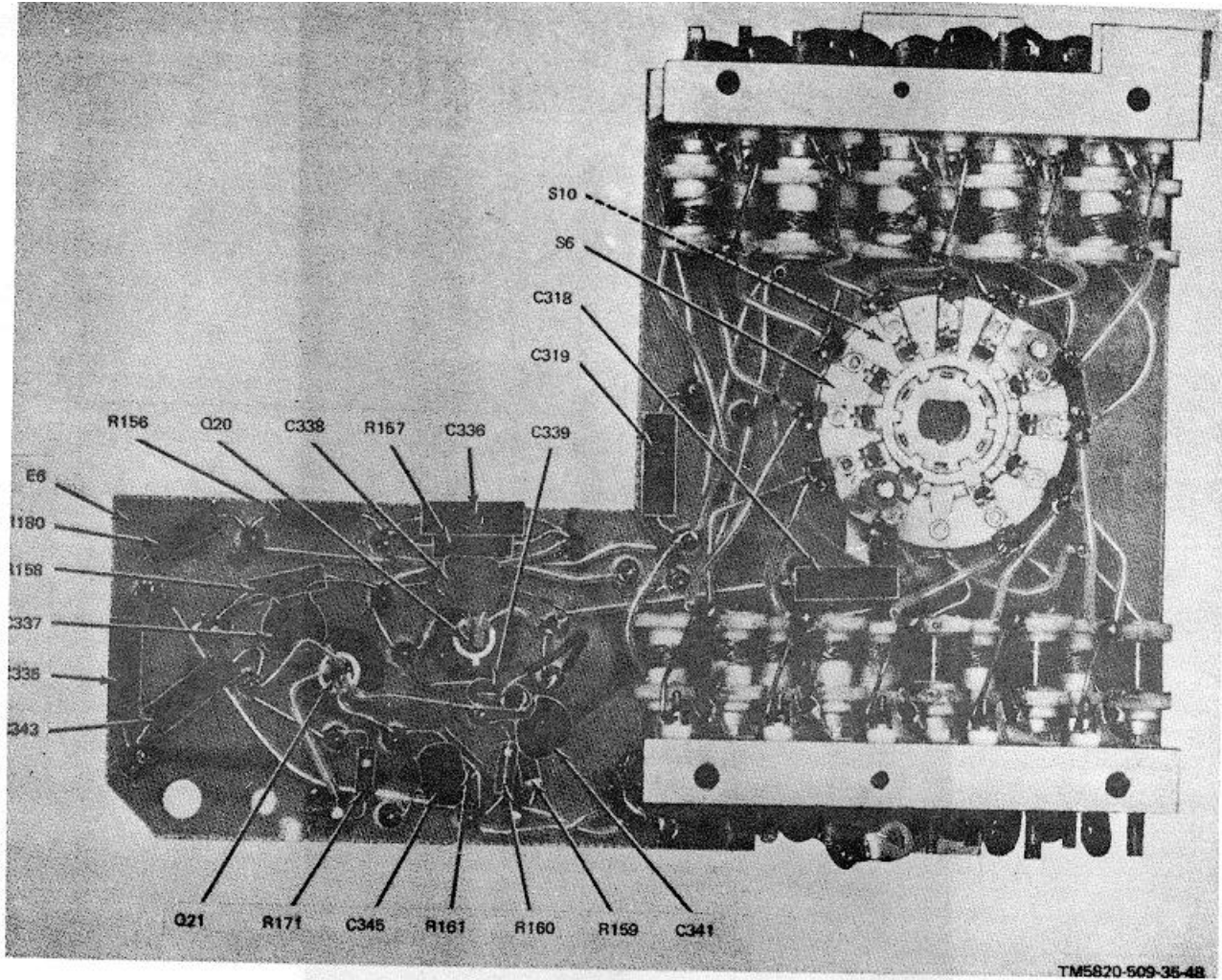

Figure 3-33. Signal Data Translator CV-1377A/PRC-47 (A8A3), Switch Assembly S6, VFO Circuit.

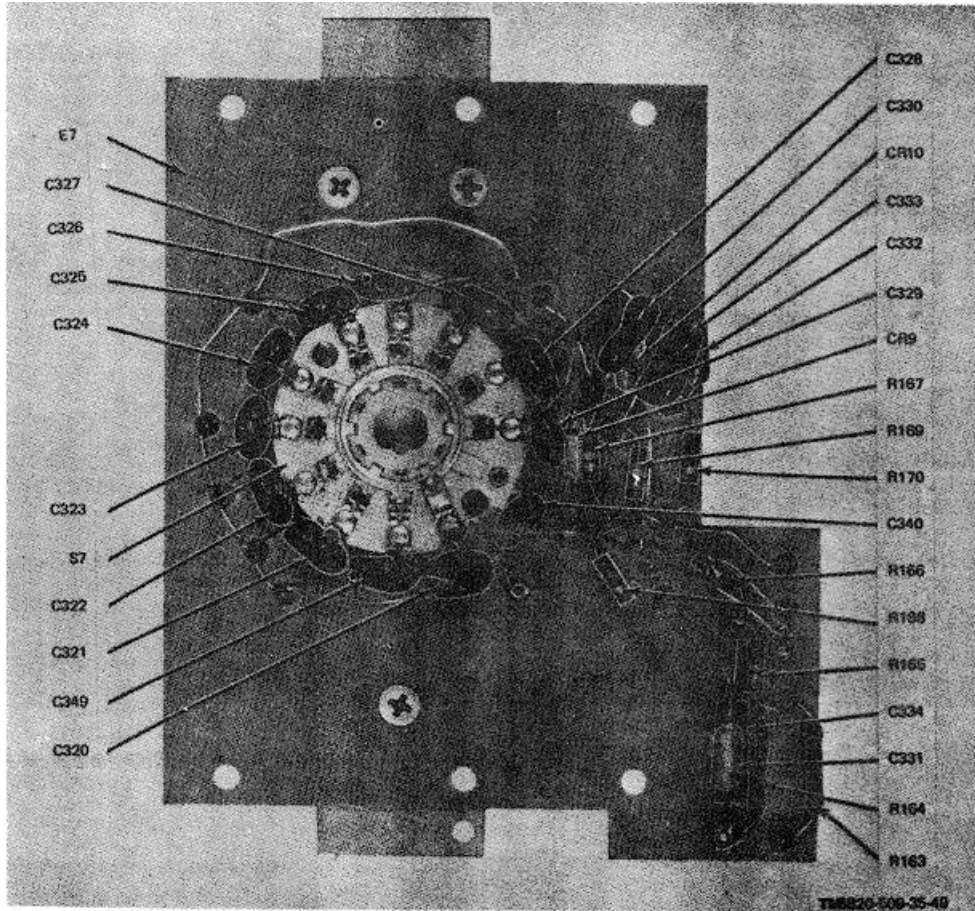

Figure 3-34. Signal Data Translator CV-1377A/PRC-47 (A8A3), Switch Assembly S7, Front View.

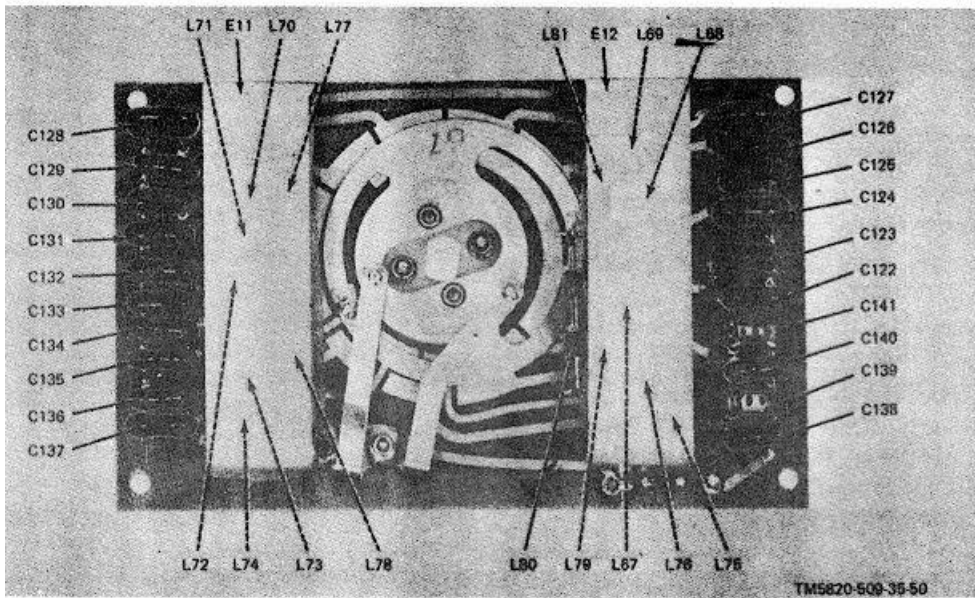

Figure 3-35. Signal Data Translator CV-1377A/PRC-47 (A8A3), Switch Assembly S8, Rear View.

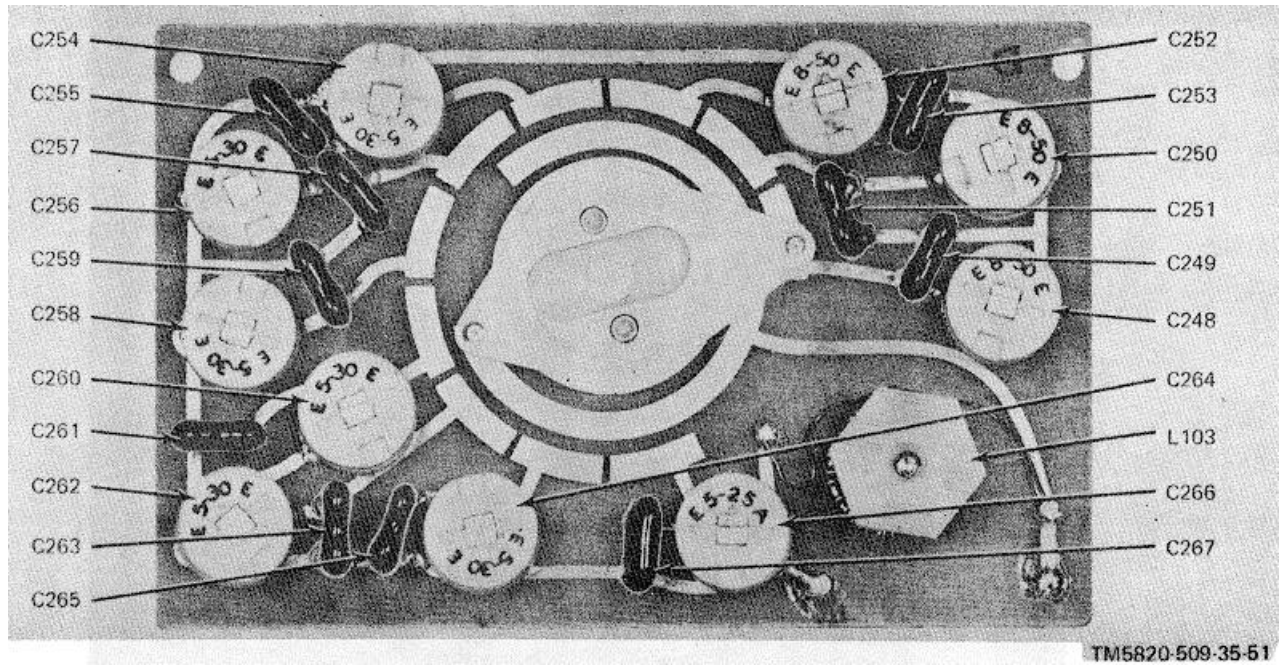

Figure 3-36. Signal Data Translator CV-1377A/PRC-47 (A8A3), Switch Assembly S9, Rear View (Rotor at Index Position no. 1).

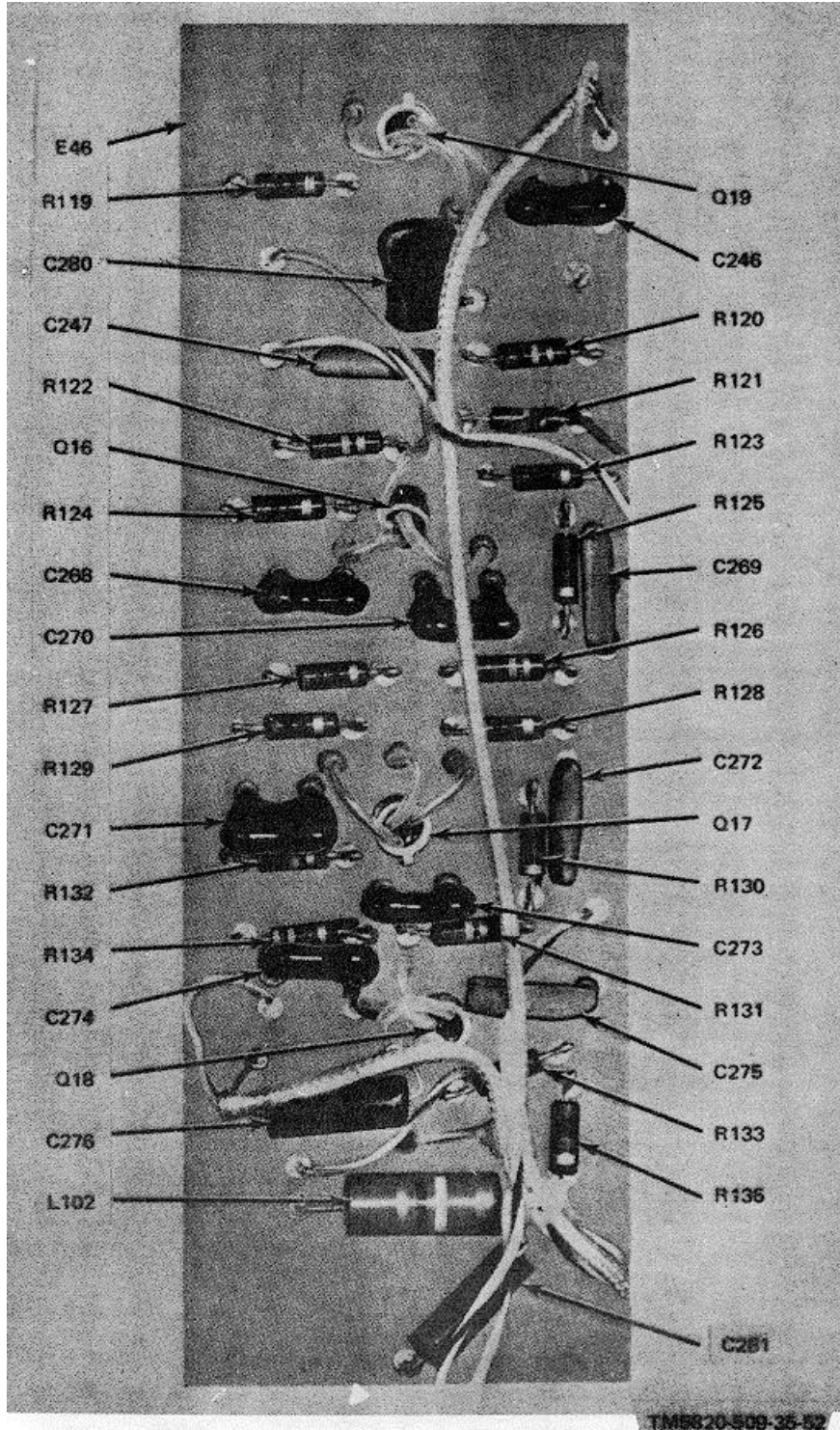

Figure 3-37. Signal Data Translator CV-1377A/PRC-47 (A8A3), Card Assembly E46.

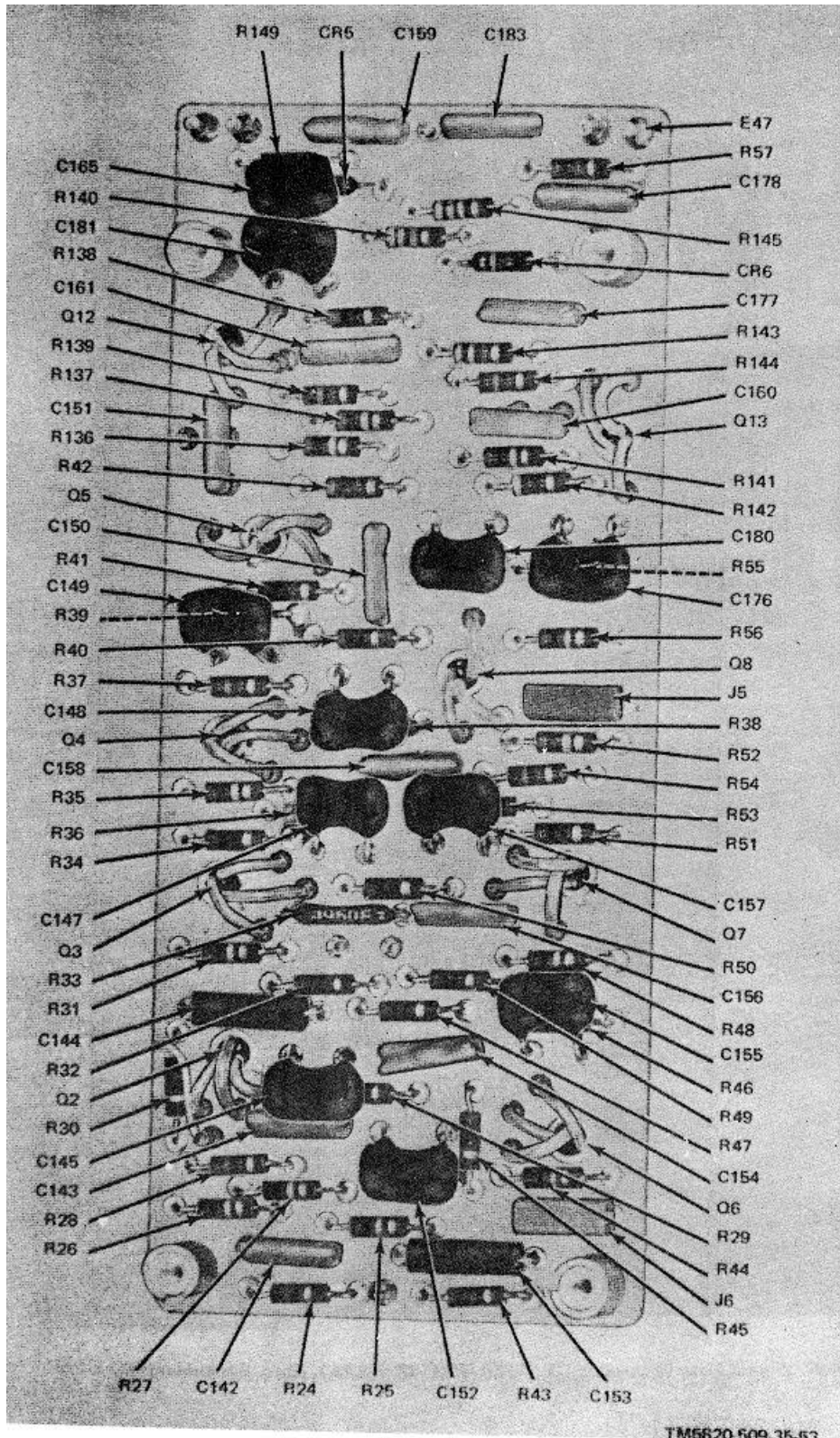

Figure 3-38. Signal Data Translator CV-1377/APRC-47 (A8A3), Card Assembly E47.

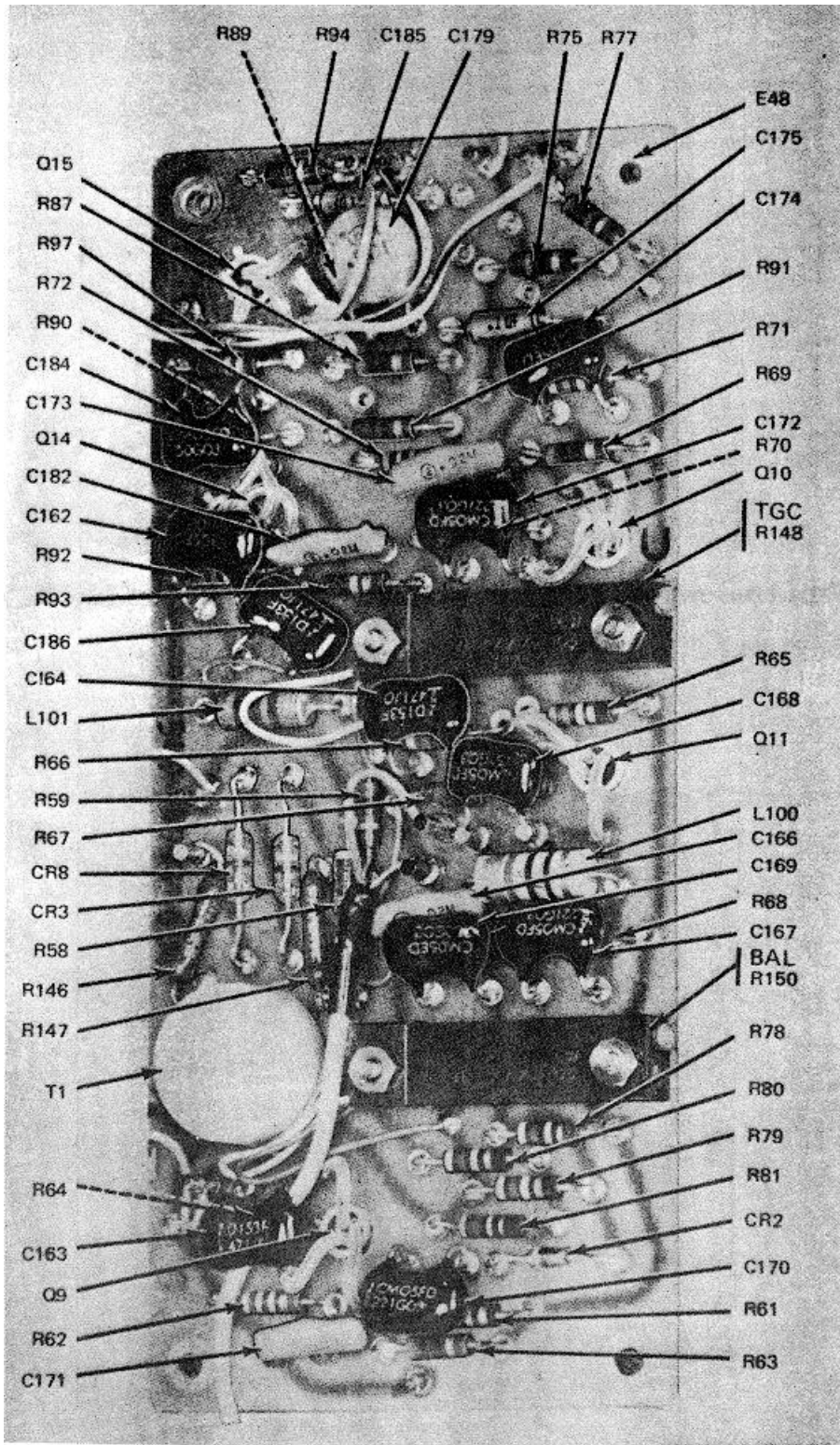
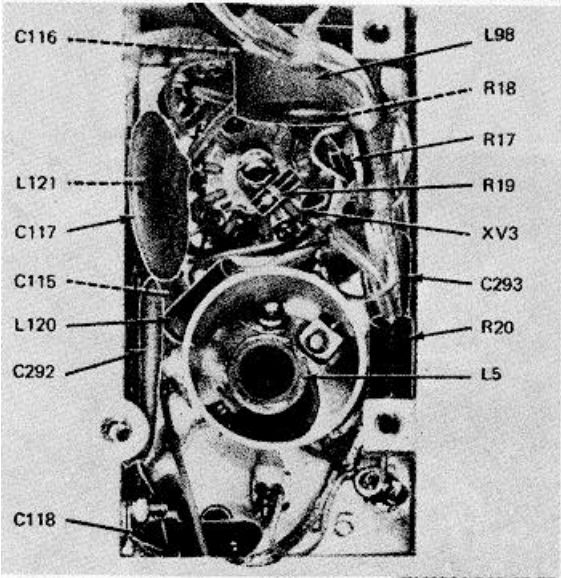

Figure 3-39. Signal Data Translator CV-1377A/PRC-47 (A8A3), Card Assembly E48.



TM5820-509-35-55

Figure 3-40. Signal Data Translator CV-1377A/PRC-47 (A8A3), Driver Tube (V3) Compartment, Bottom View.

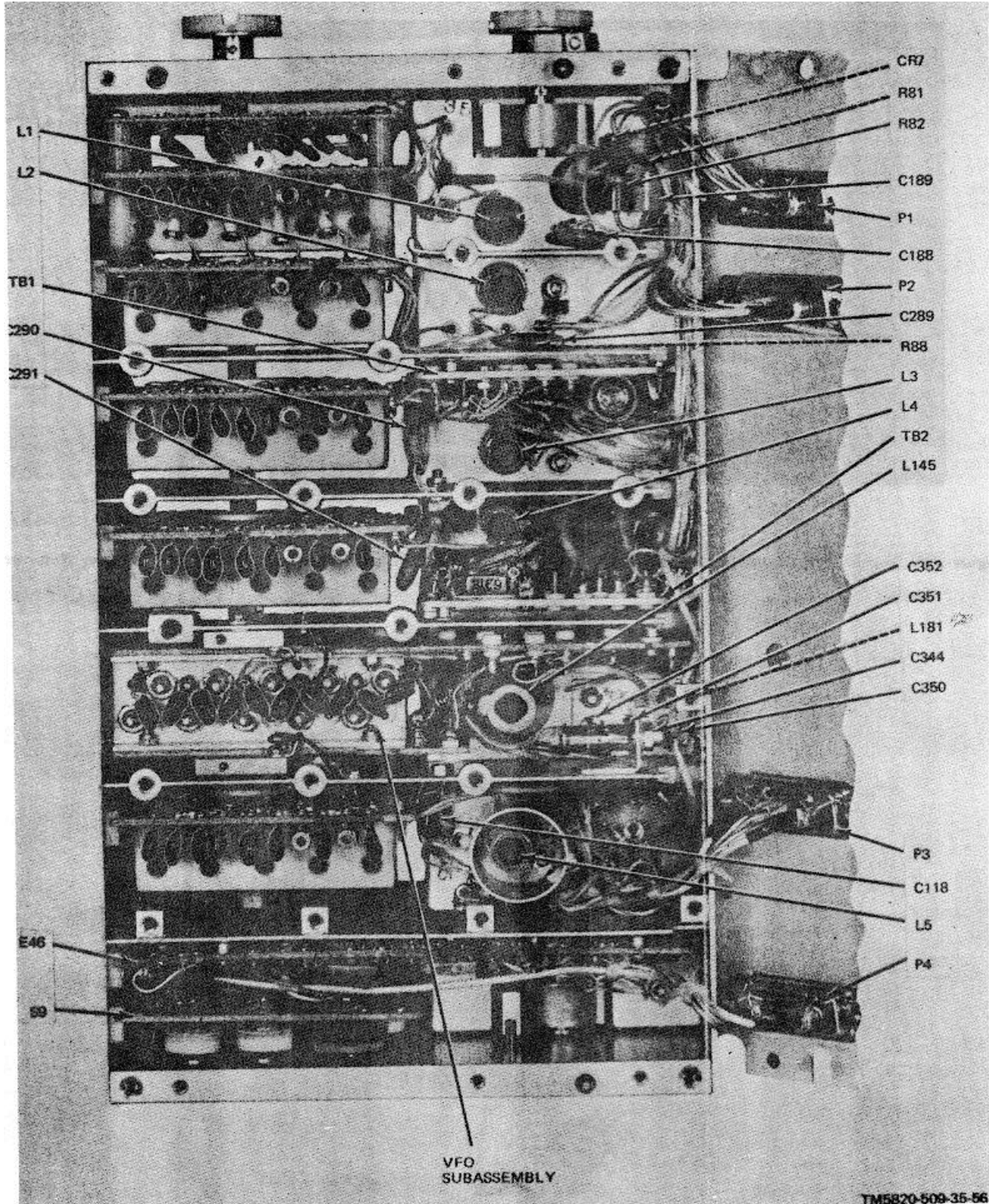
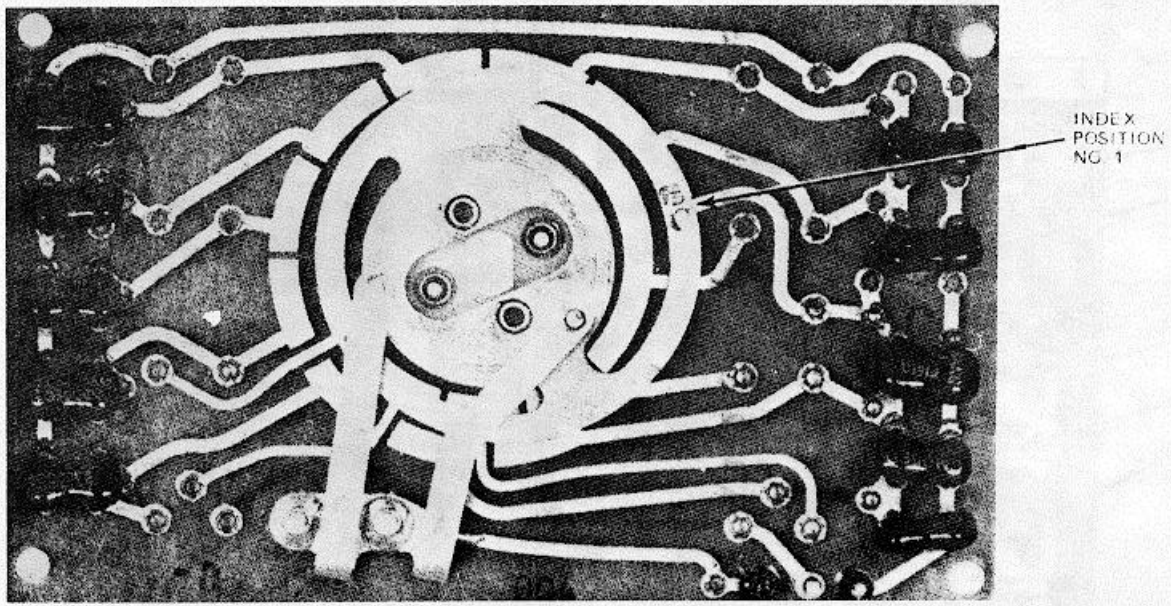
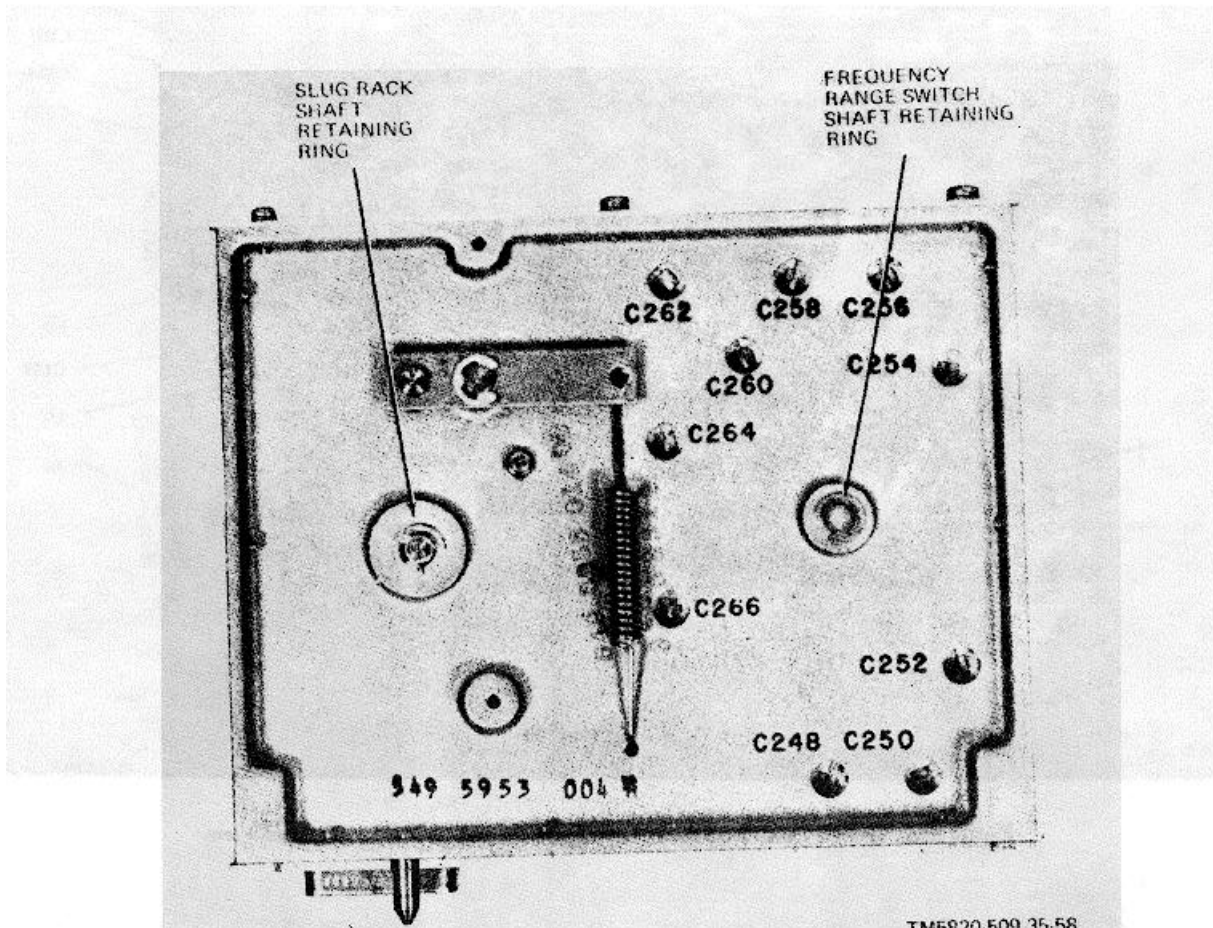

Figure 3-41. Signal Data Translator CV-1377A/PRC-47 (A8A3), Bottom View.



TM5820 509 35 57

Figure 3-42. Signal Data Translator CV-1377A/PRC-47 (A8A3), Typical Switch Card (S1 through S8) Showing Rotor at Index Position no. 1.



TM5820-509 35-58

Figure 3-43. Signal Data Translator CV-1377/PRC-47 (A8A3), Rear View, Frequency Range Switch Shaft Retaining Ring.

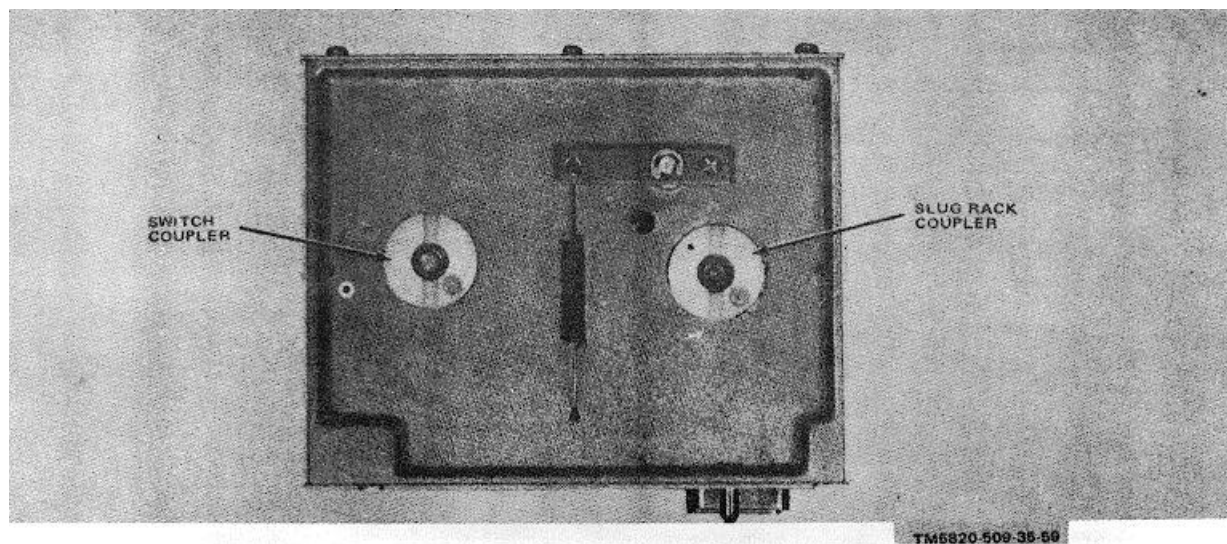

Figure 3-44. Signal Data Translator CV-1377A/PRC-47 (A8A3), Front View, Coupler Position as 2000 kHz Dial Setting.

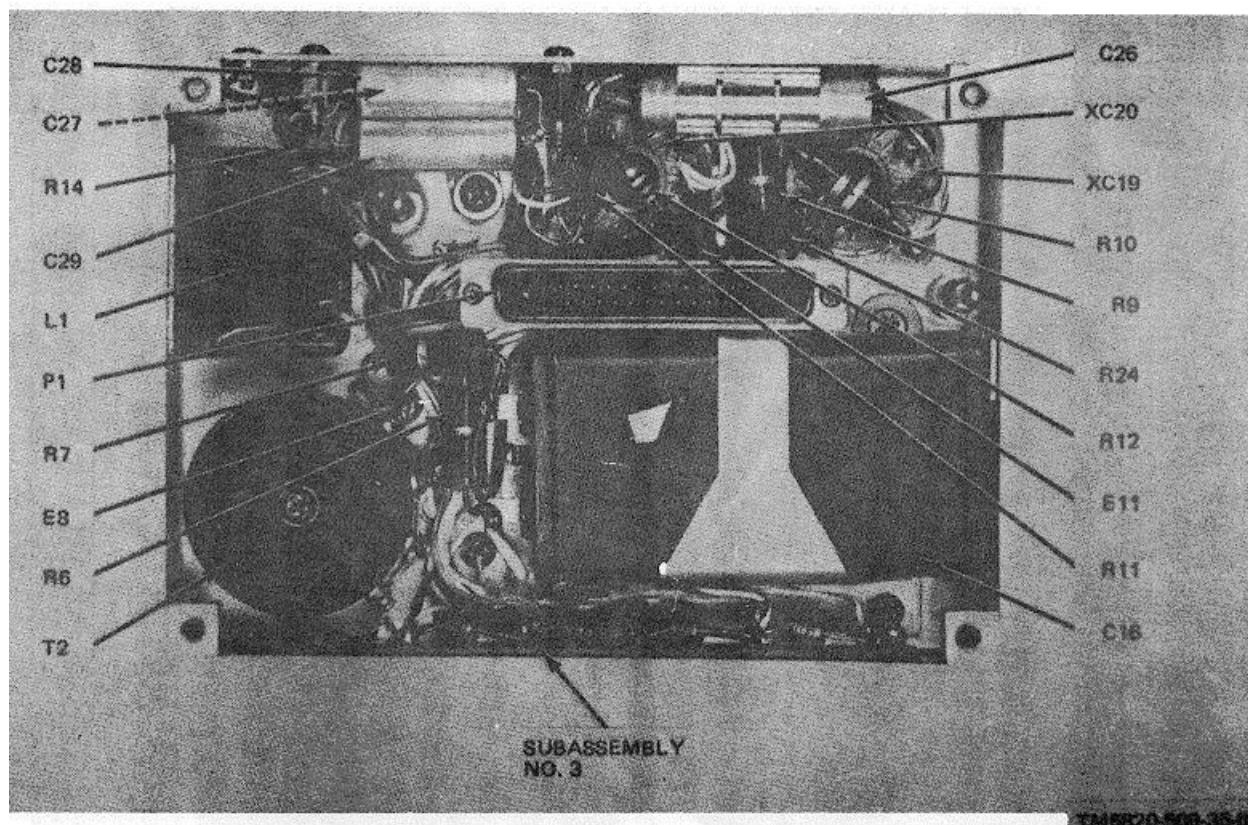

Figure 3-45. Power Supply PP-3518/PRC-47 (A8A5), Bottom View, Chassis.

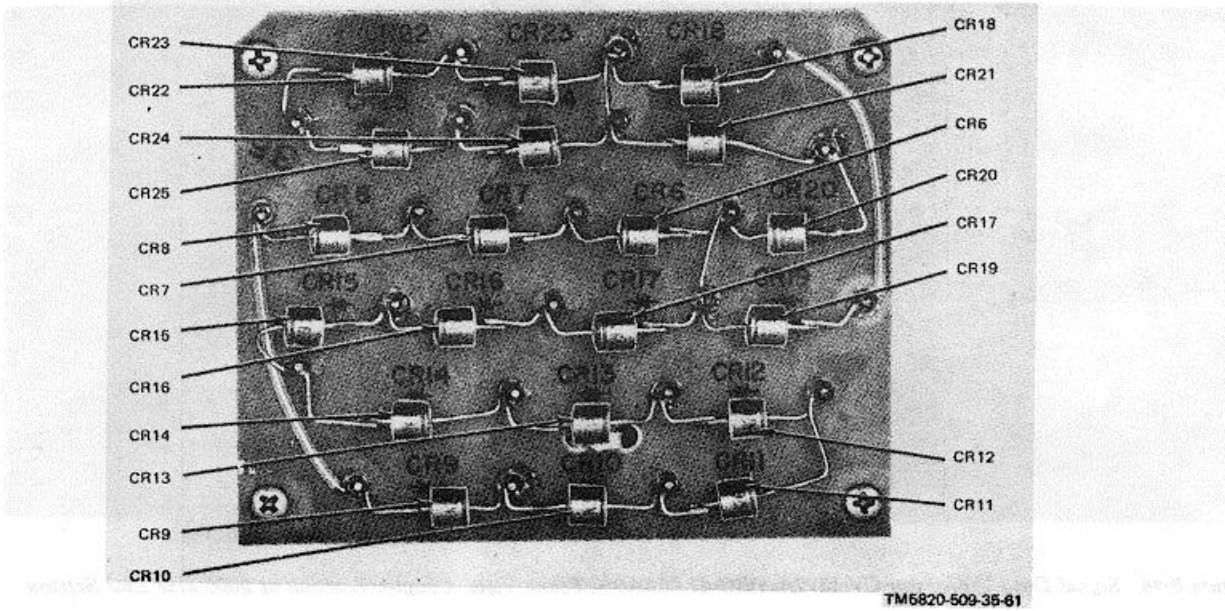

Figure 3-46. Power Supply PP-3581/PRC-47 (A8A5), Subassembly no. 1, Front View

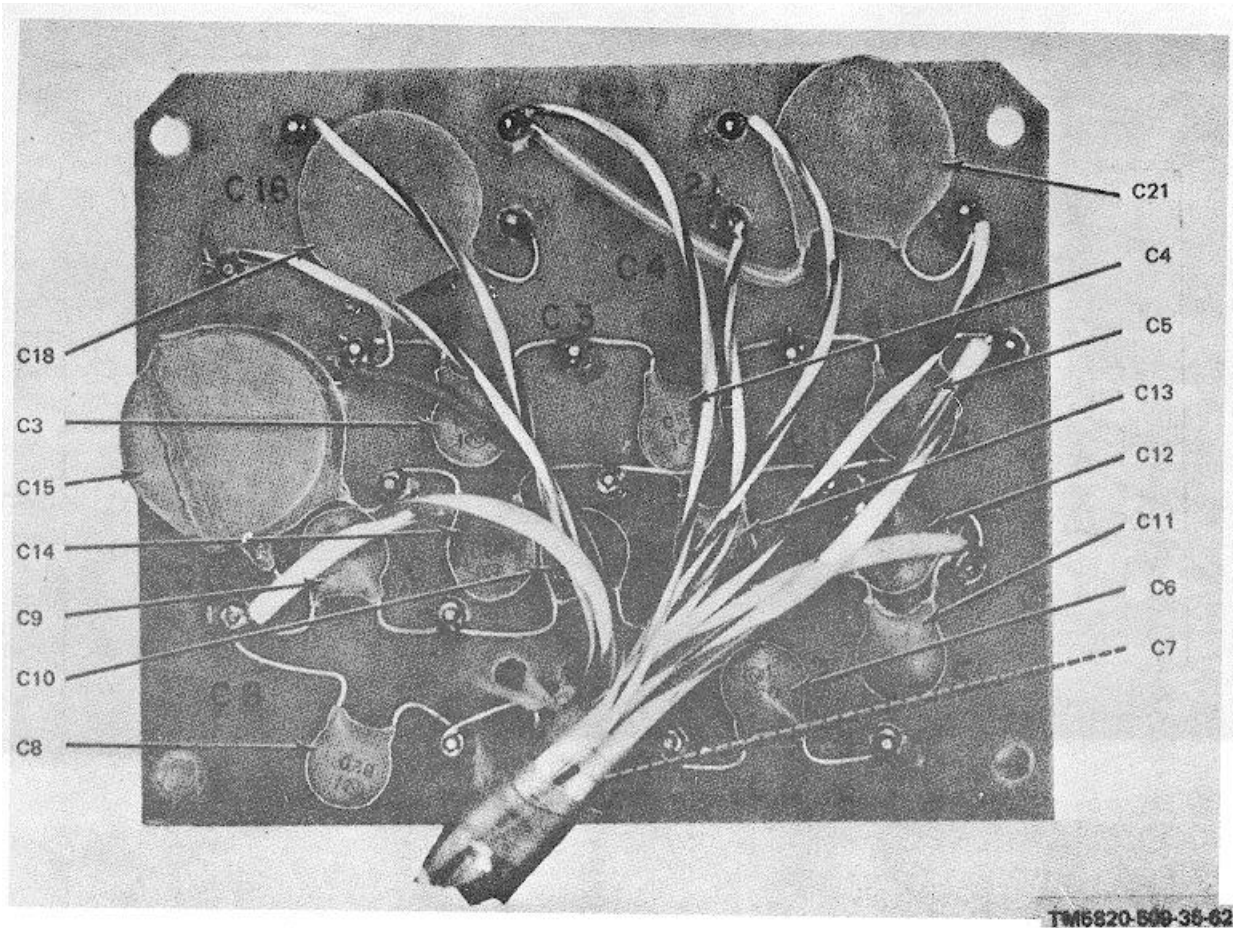

Figure 3-47. Power Supply PP-3581/PRC-47 (A8A5), Subassembly no. 1, Rear View.

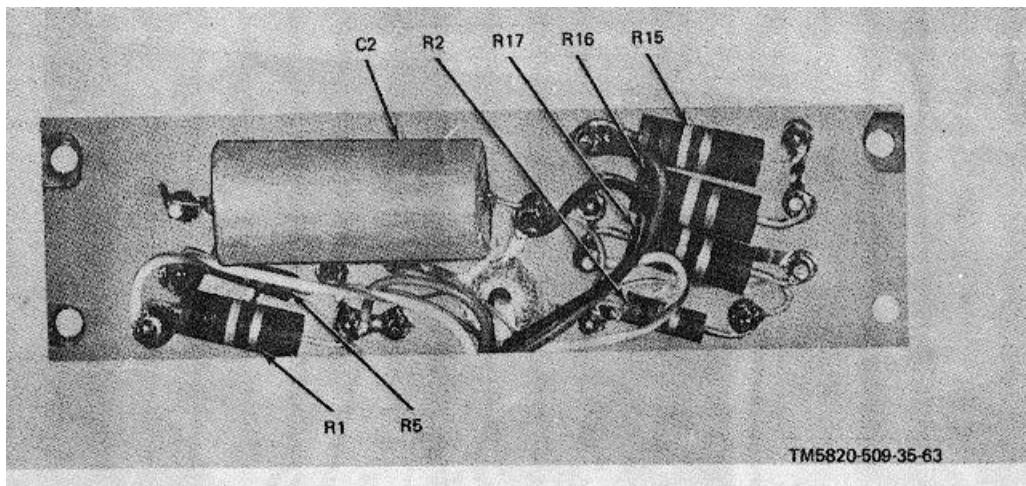

Figure 3-48. Power Supply PP-3518/PRC-47 (A8A5), Subassembly no. 2.

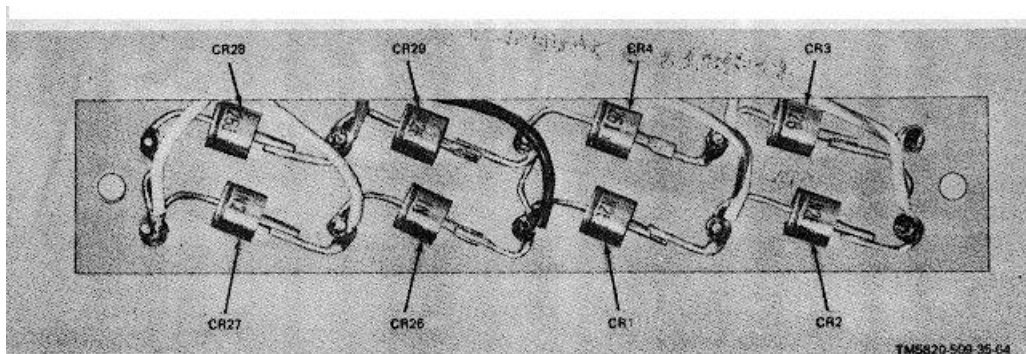
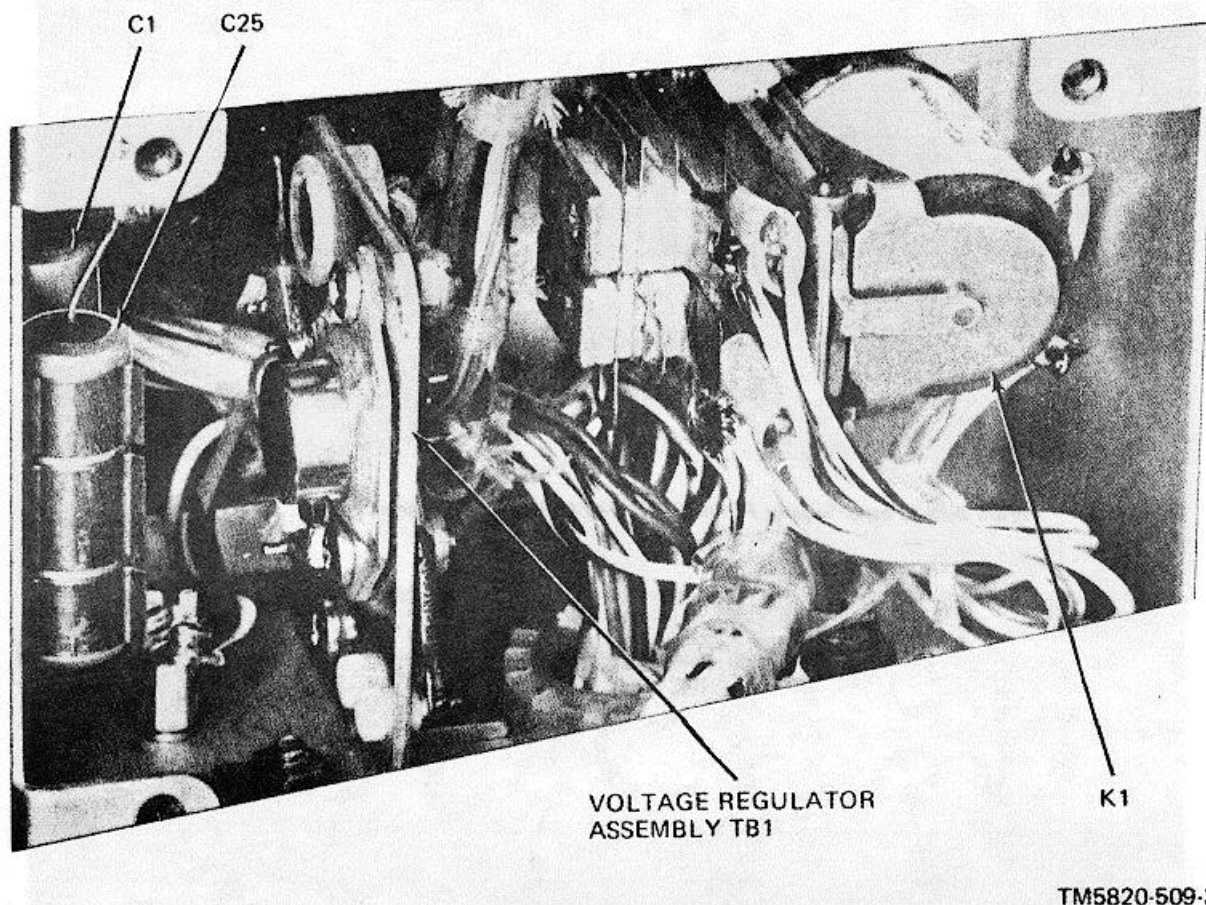

Figure 3-49. Power Supply PP-3518/PRC 47 (A8A5), Subassembly no. 3.



TM5820-509-35-65

Figure 3-50. Power Supply PP-3518/PRC-47 (A8A5), Upper Chassis Assembly.

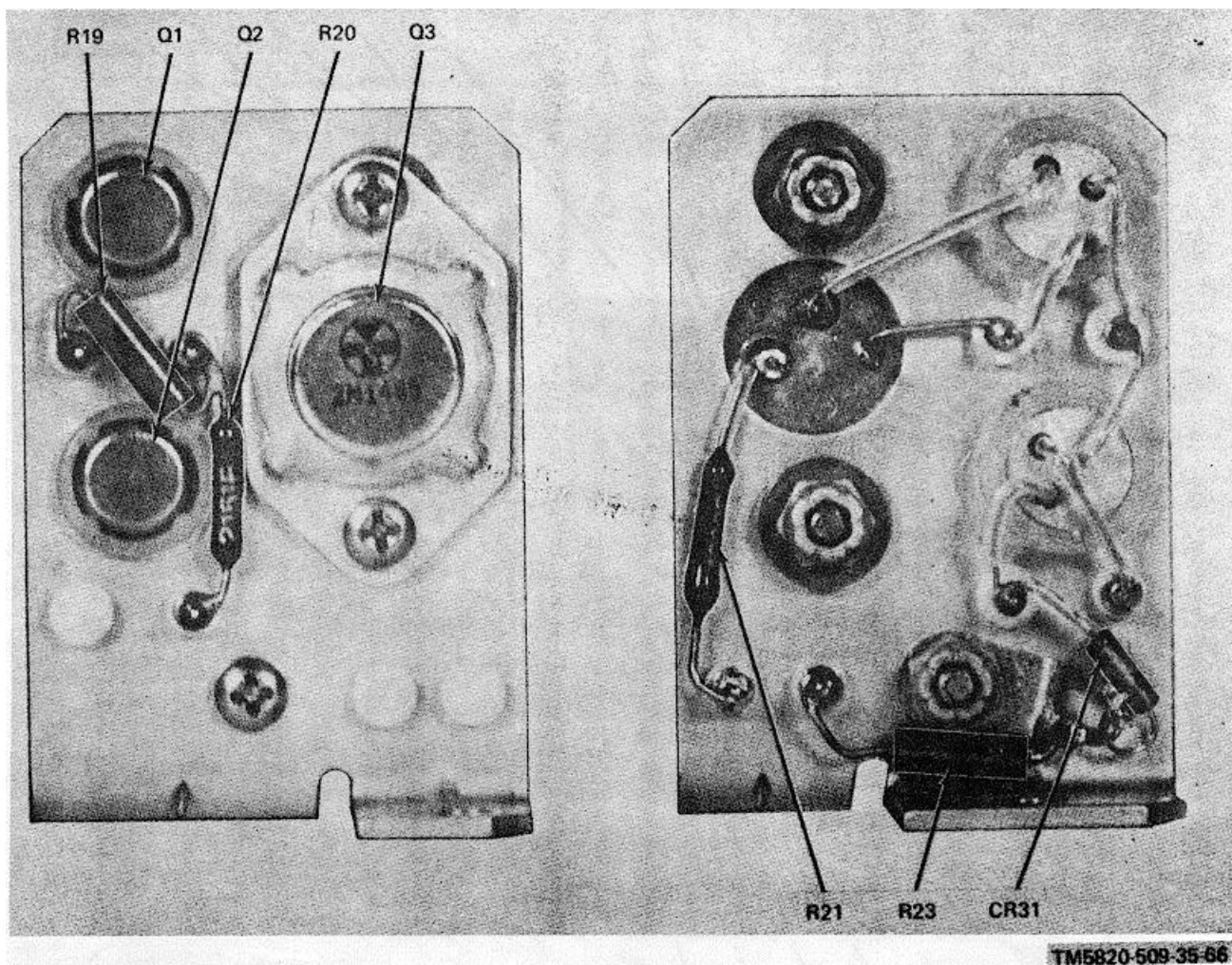

Figure 3-51. Power Supply PP-3518/PRC-47 (A8A5), Voltage Regulator Assembly TB1.

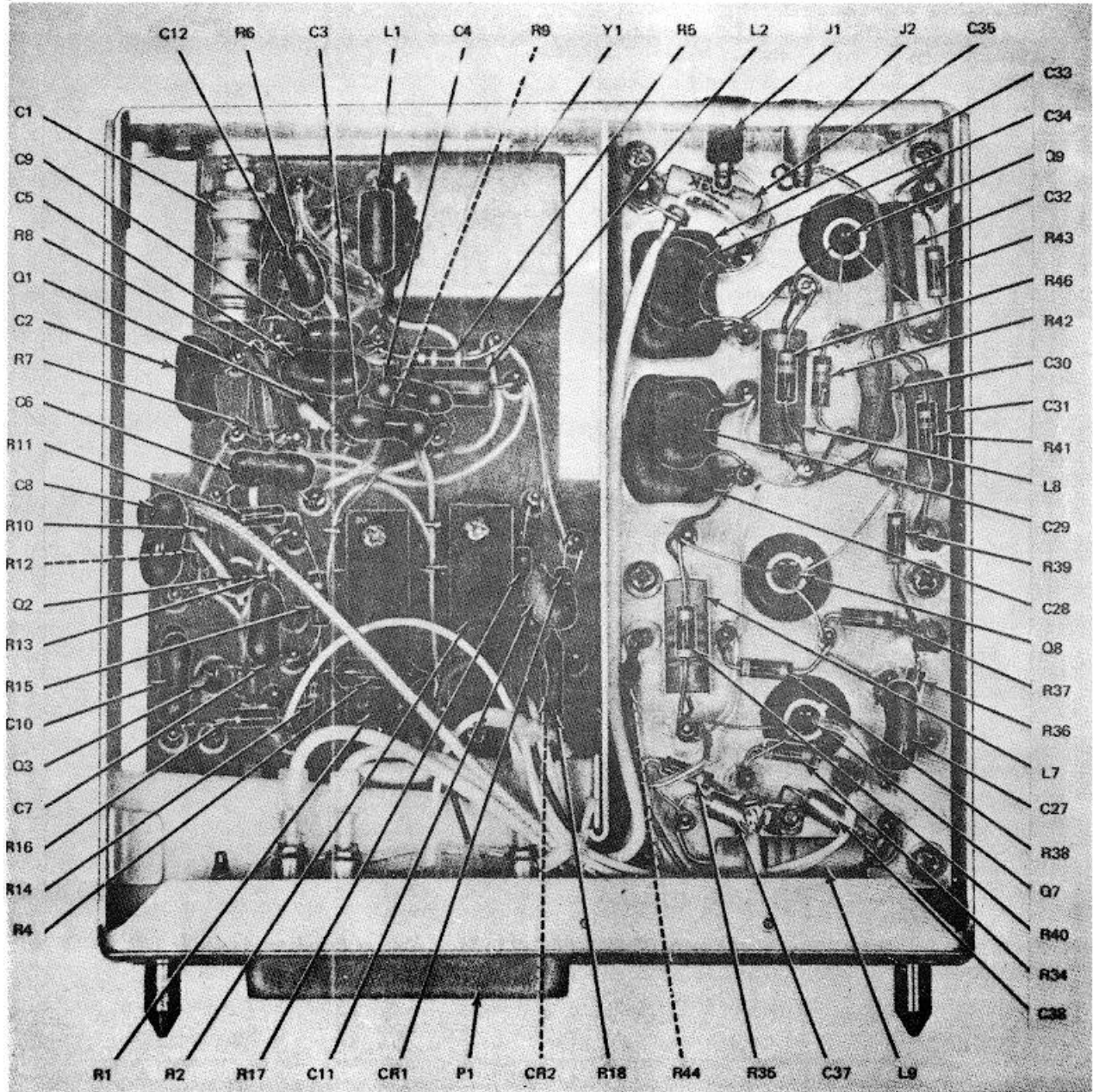

Figure 3-52. Radio Frequency Oscillator O-1032/PRC-47 (A8A6), Side View, Cover Removed, Card Assemblies E1 and E2.

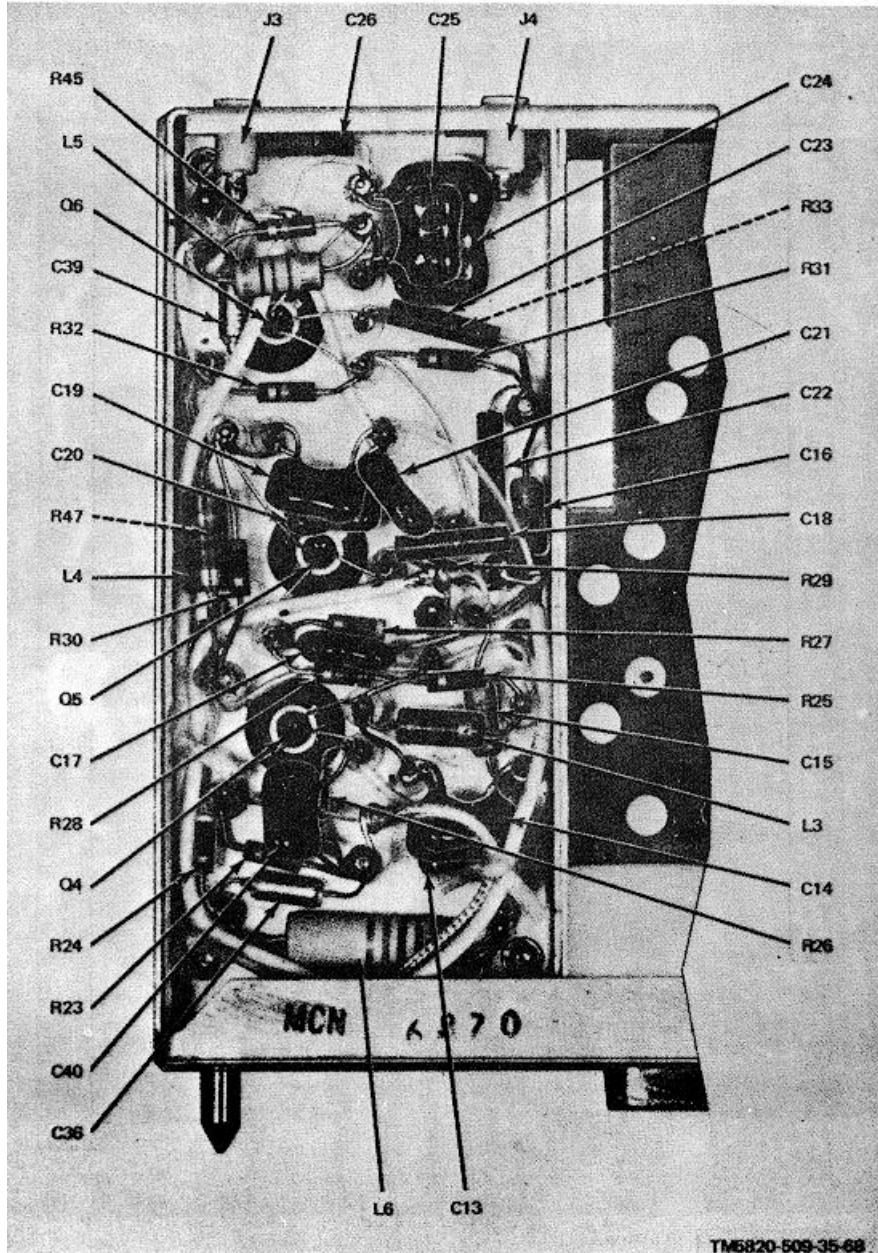

Figure 3-53. Radio Frequency Oscillator O-1032/PRC-47 (A8A6), Side View, Cover Removed, Chassis Assembly.

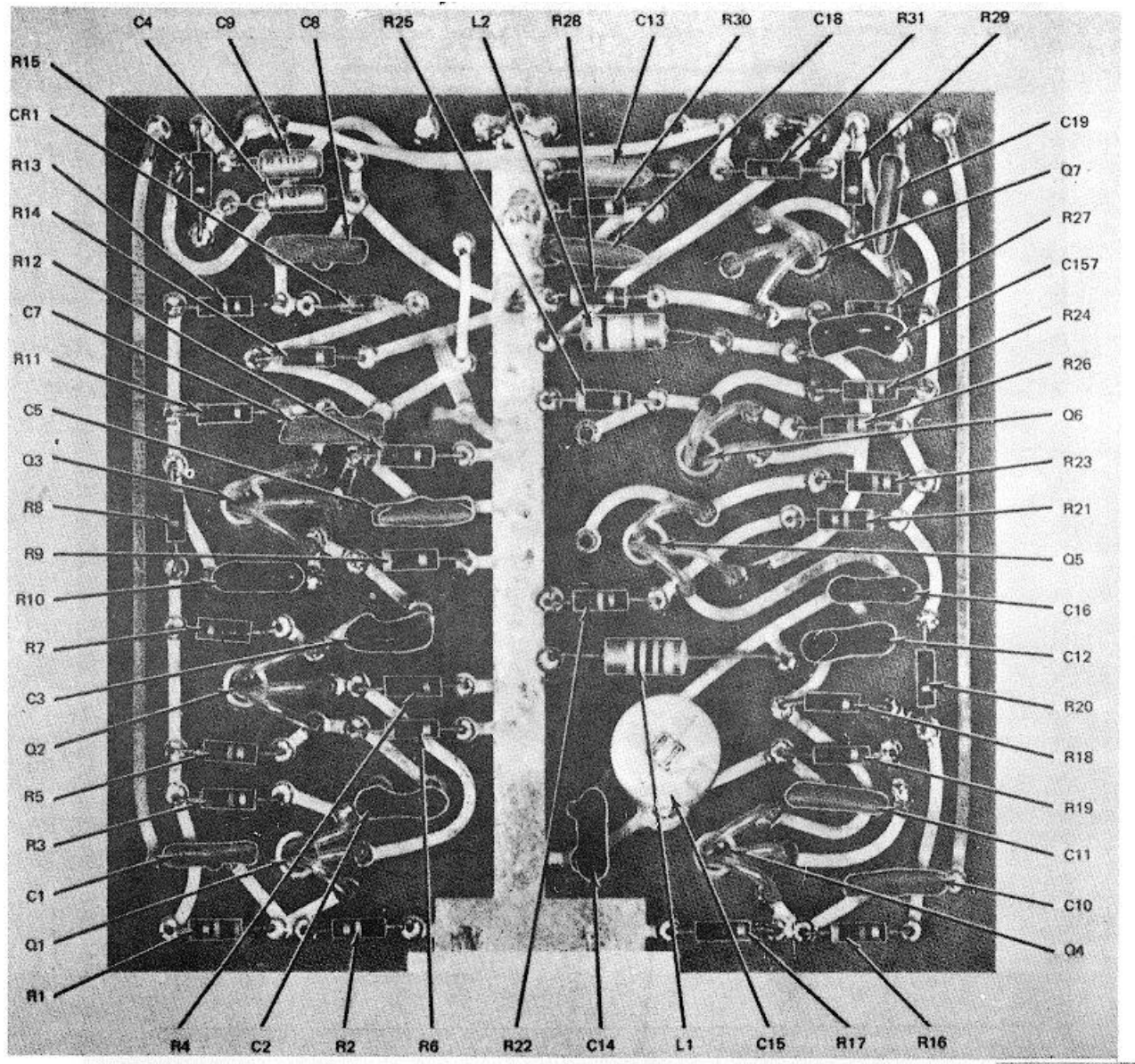

Figure 3-54. Oscillator Control C-4311/PRC-47 (A8A7), Card Assembly E1.

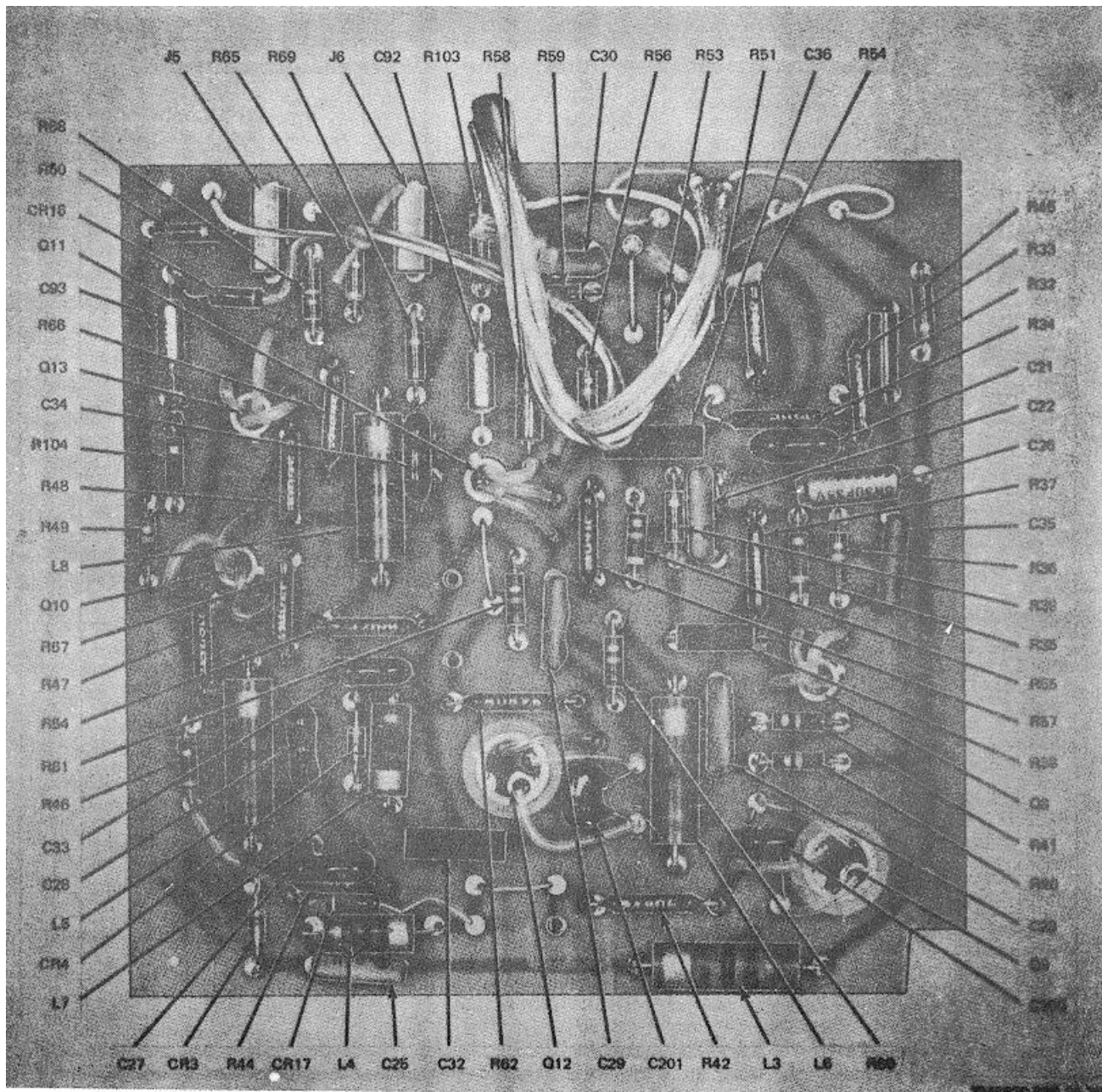

Figure 3-55. Oscillator Control C-4311/PRC-47 (A8A7), Card Assembly E2.

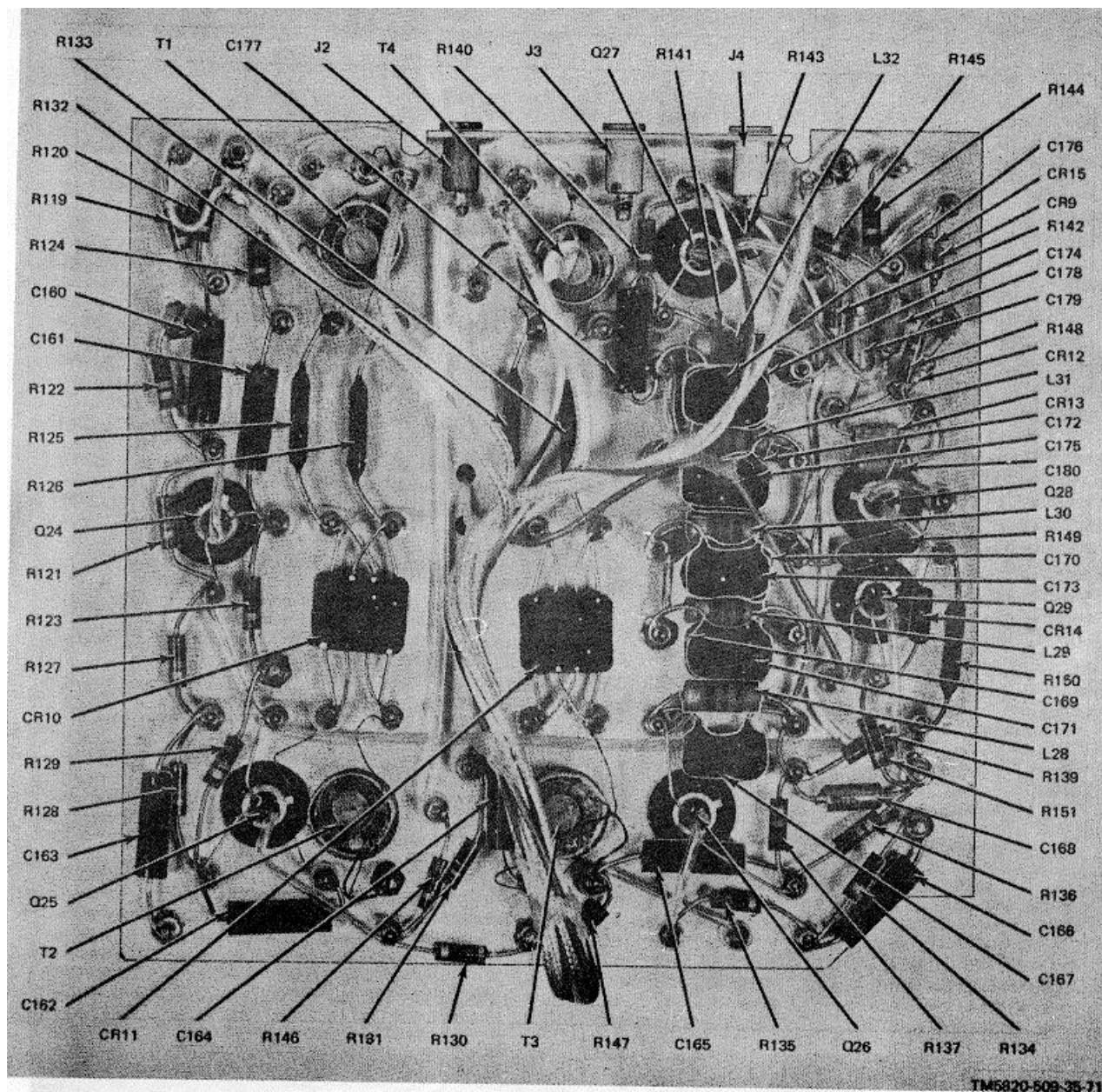

Figure 3-56. Oscillator Control C-4311/PRC-47 (A8A7), Card Assembly TB1.

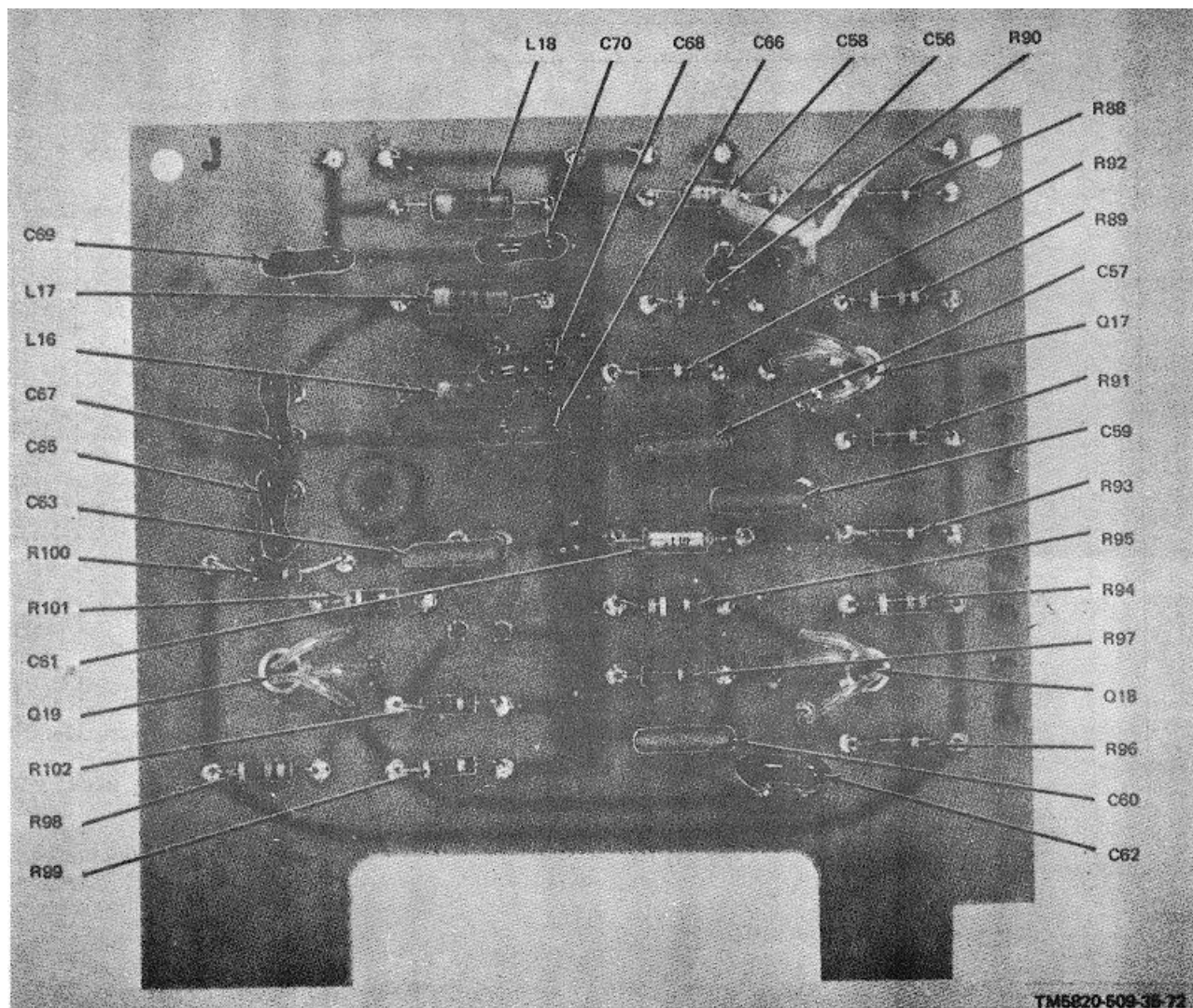

Figure 3-57. Oscillator Control C-4311/PRC 47 (A8A7), Card Assembly E4.

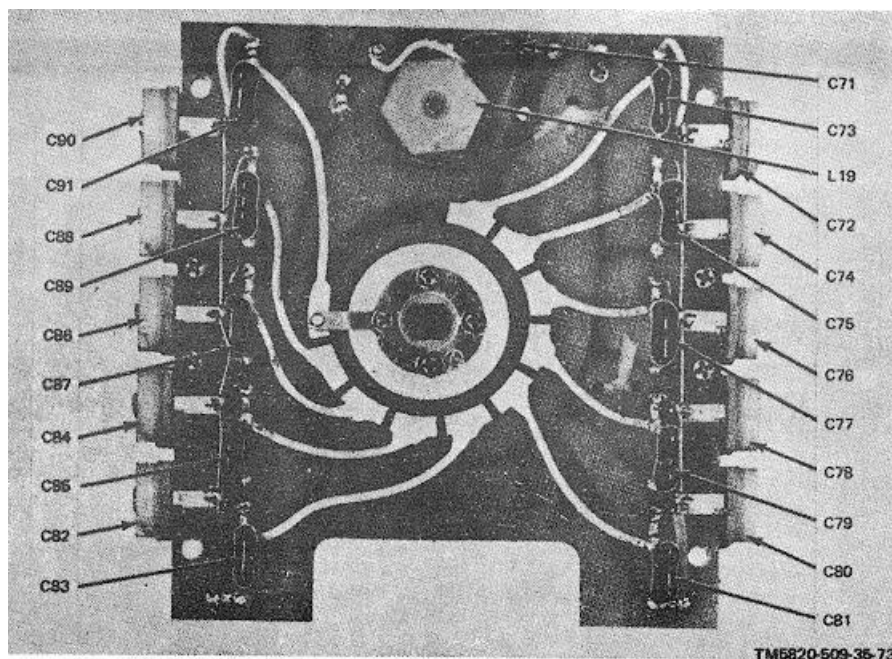

Figure 3-58. Oscillator Control C-4311/PRC-47 (A8A7), Card Assembly E5.

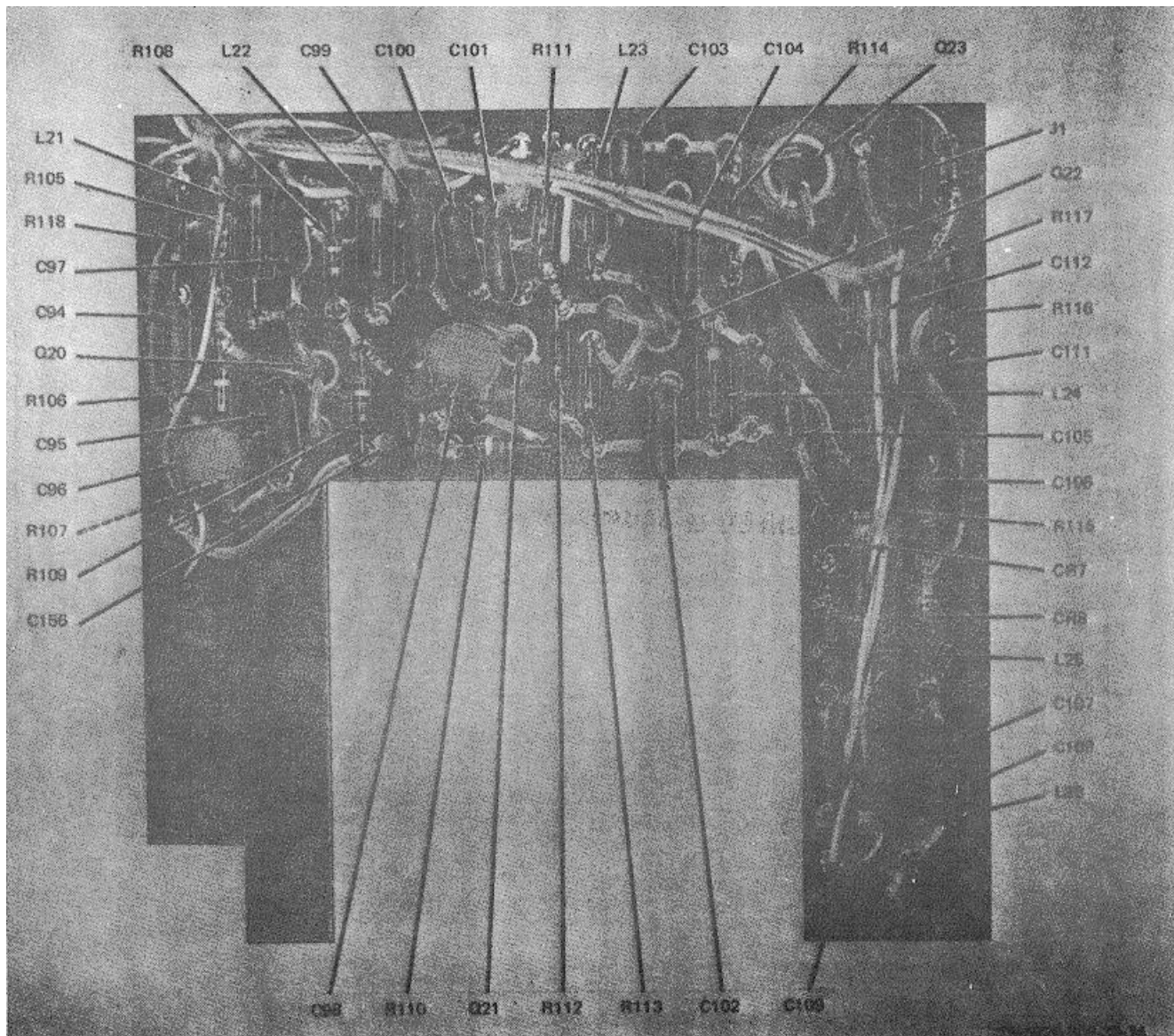

Figure 3-59. Oscillator Control C-4311/PRC-47 (A8A7), Card Assembly E6.

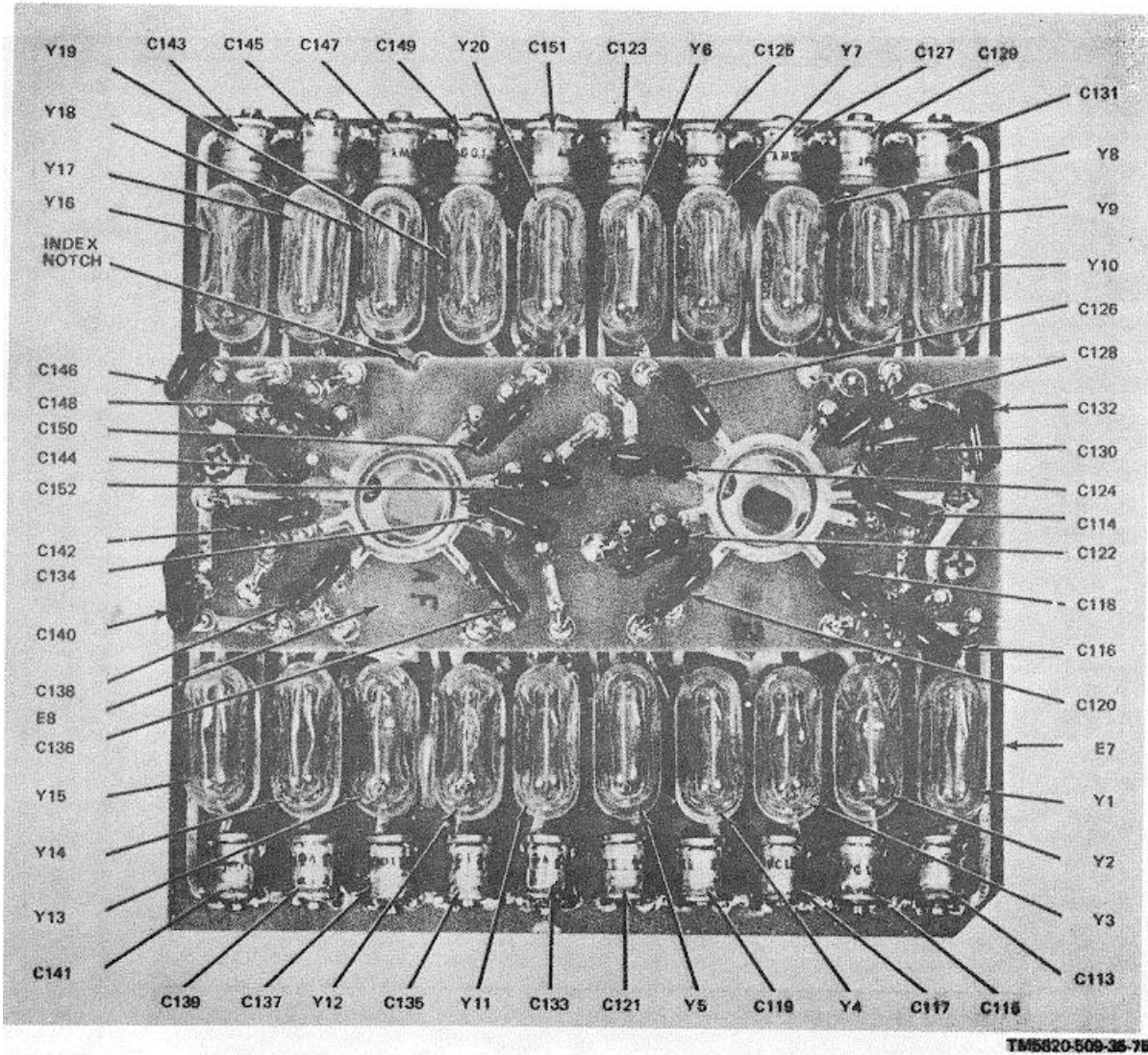

Figure 3-60. Oscillator Control C-4311/PRC-47 (A8A7), Card Assemblies E7 and E8, Front View.

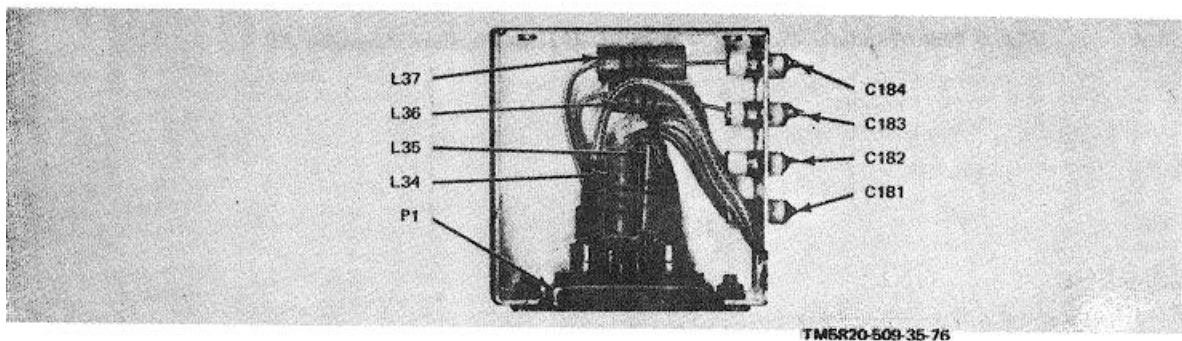

Figure 3-61. Oscillator Control C-4311 PRC-47 (A8A7), Line Filter Assembly At Connector P1, Cover Removed.

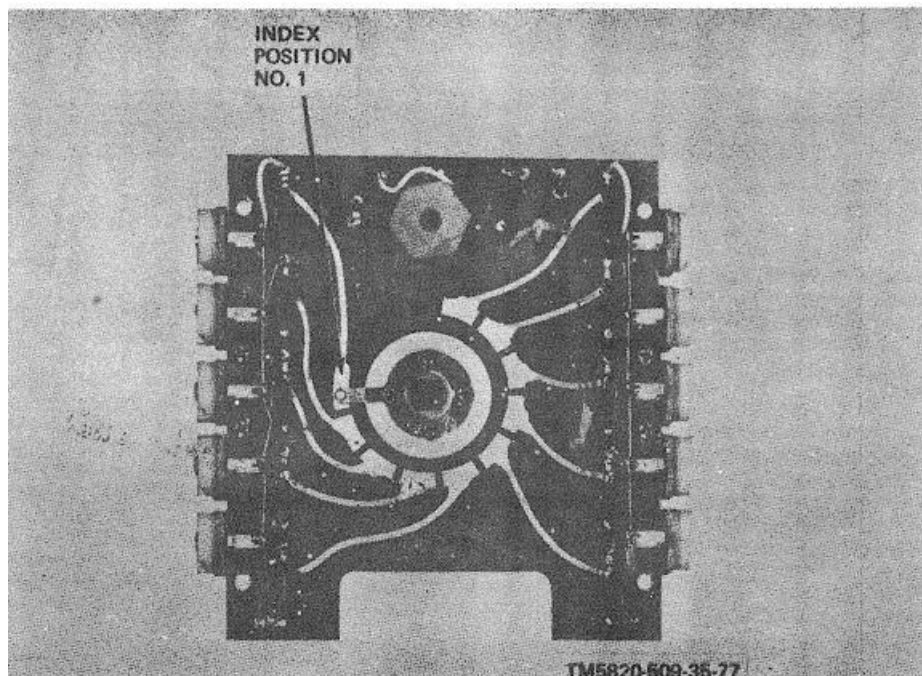
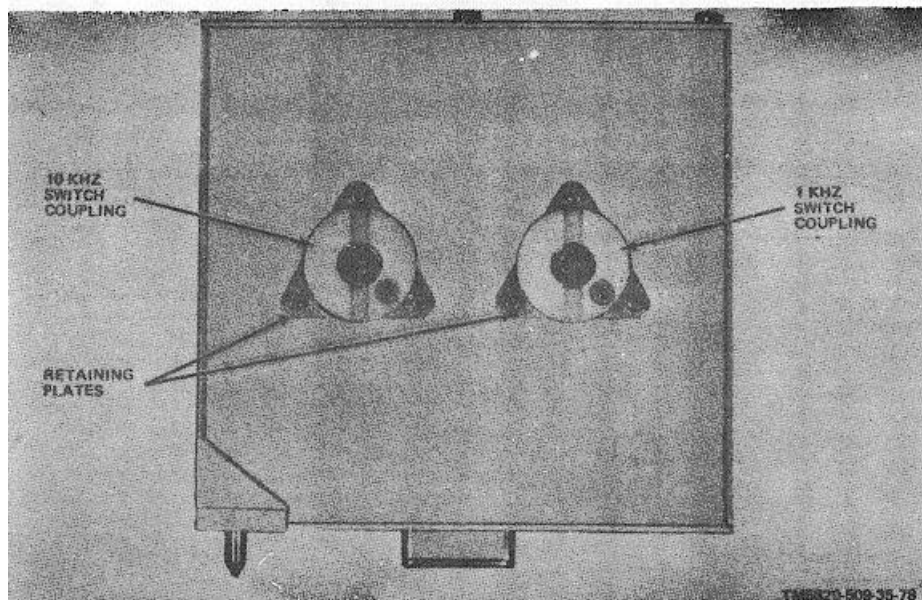

Figure 3-62. Oscillator Control C-4311/PRC-47 (A8A7), Switch Card S5 With Rotor Shown in Index Position no. 1.



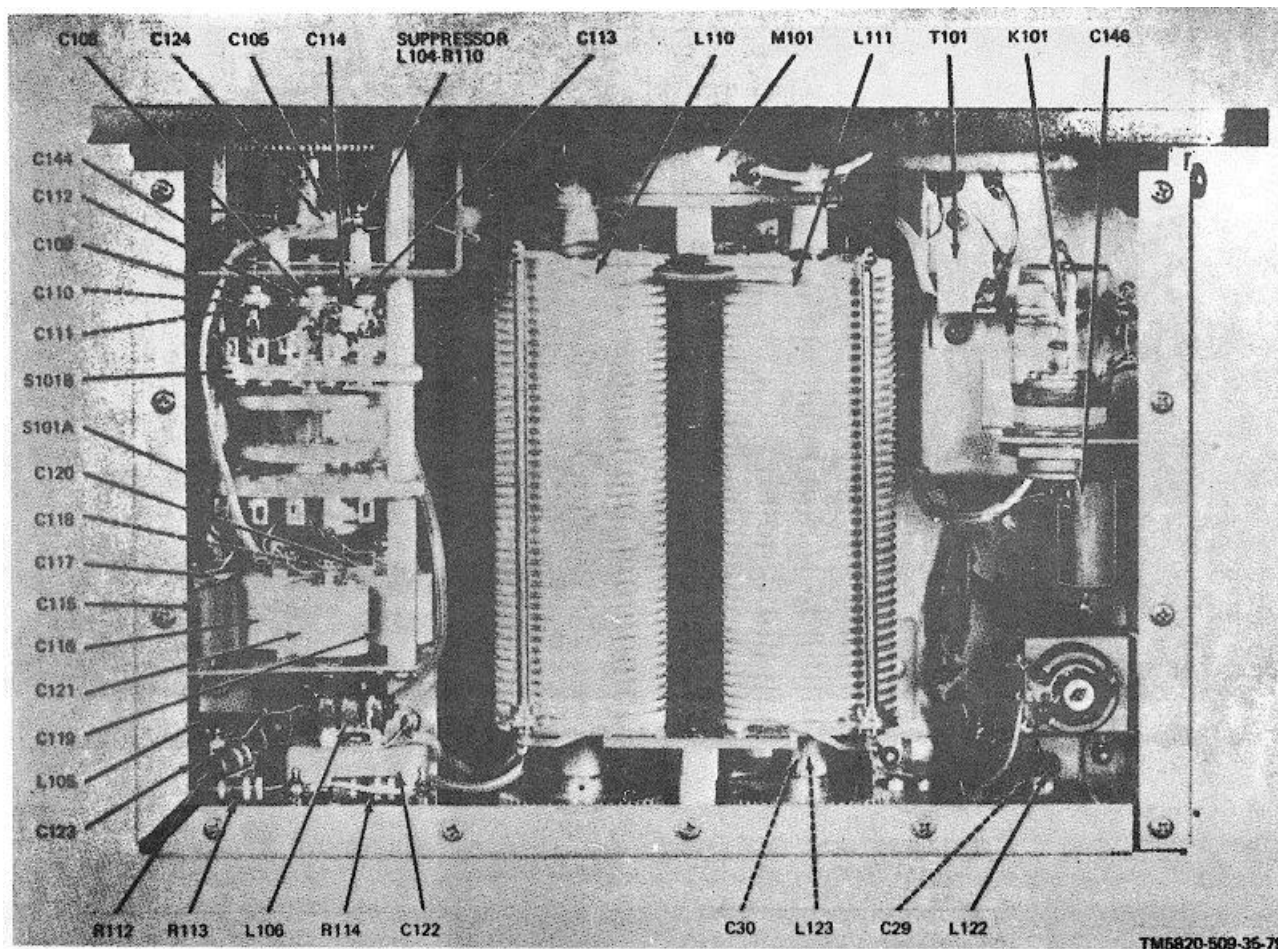

Figure 3-64. Power Amplifier Compartment (A8A4A1), Top View, Cover Removed.

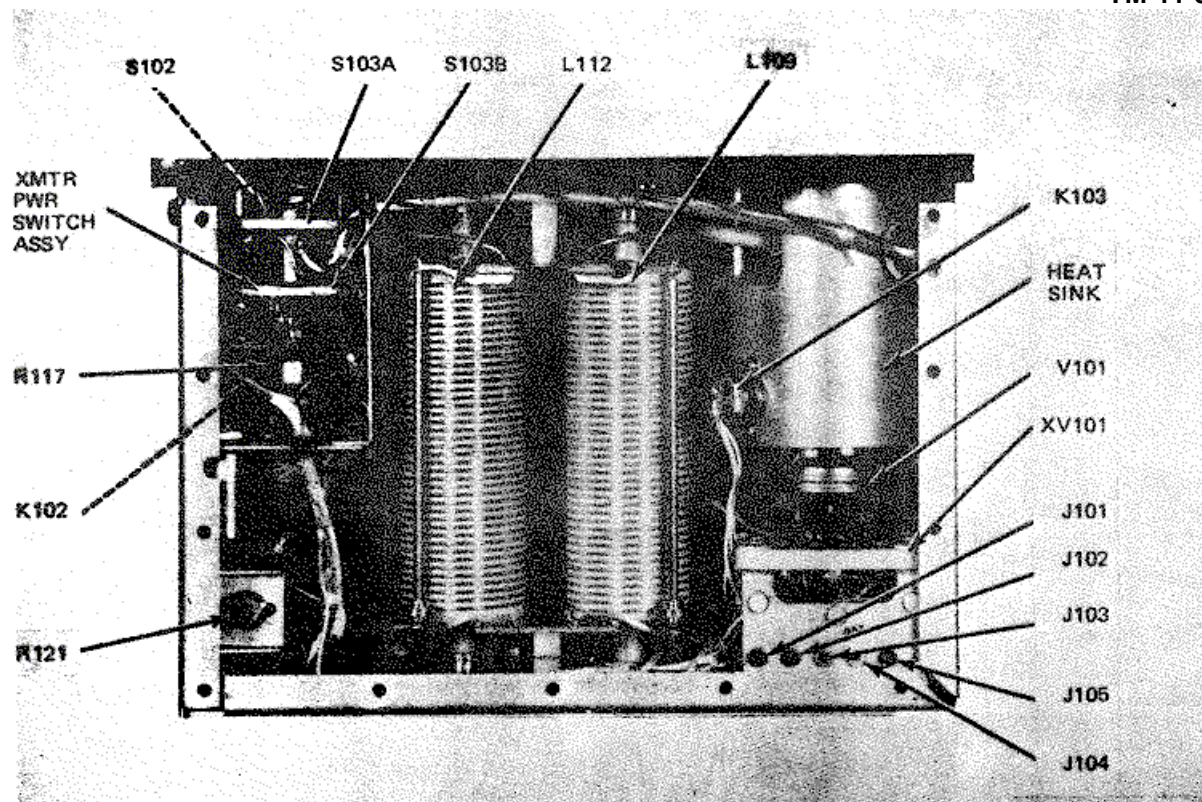

Figure 3-65. Power Amplifier Compartment (A8A4A1) , Bottom View, Cover Removed.

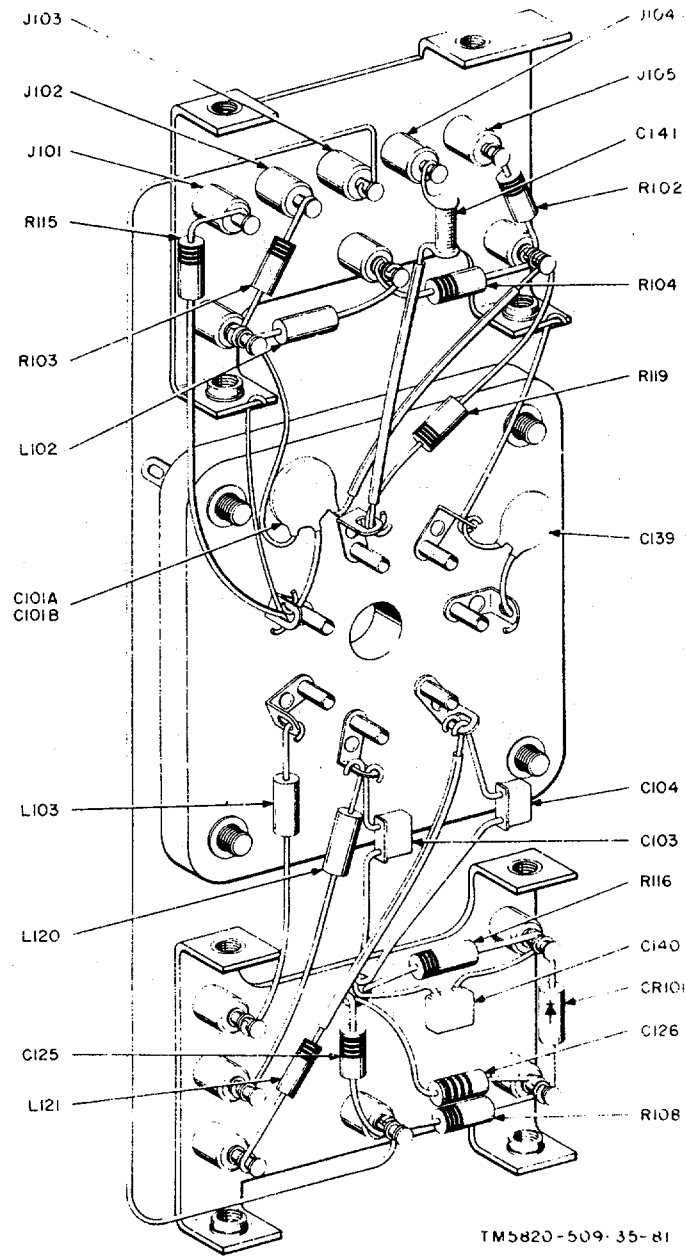

Figure 3-66. Power Amplifier Compartment (A8A4A1) , Power Amplifier Subassembly Parts Location.
3-56

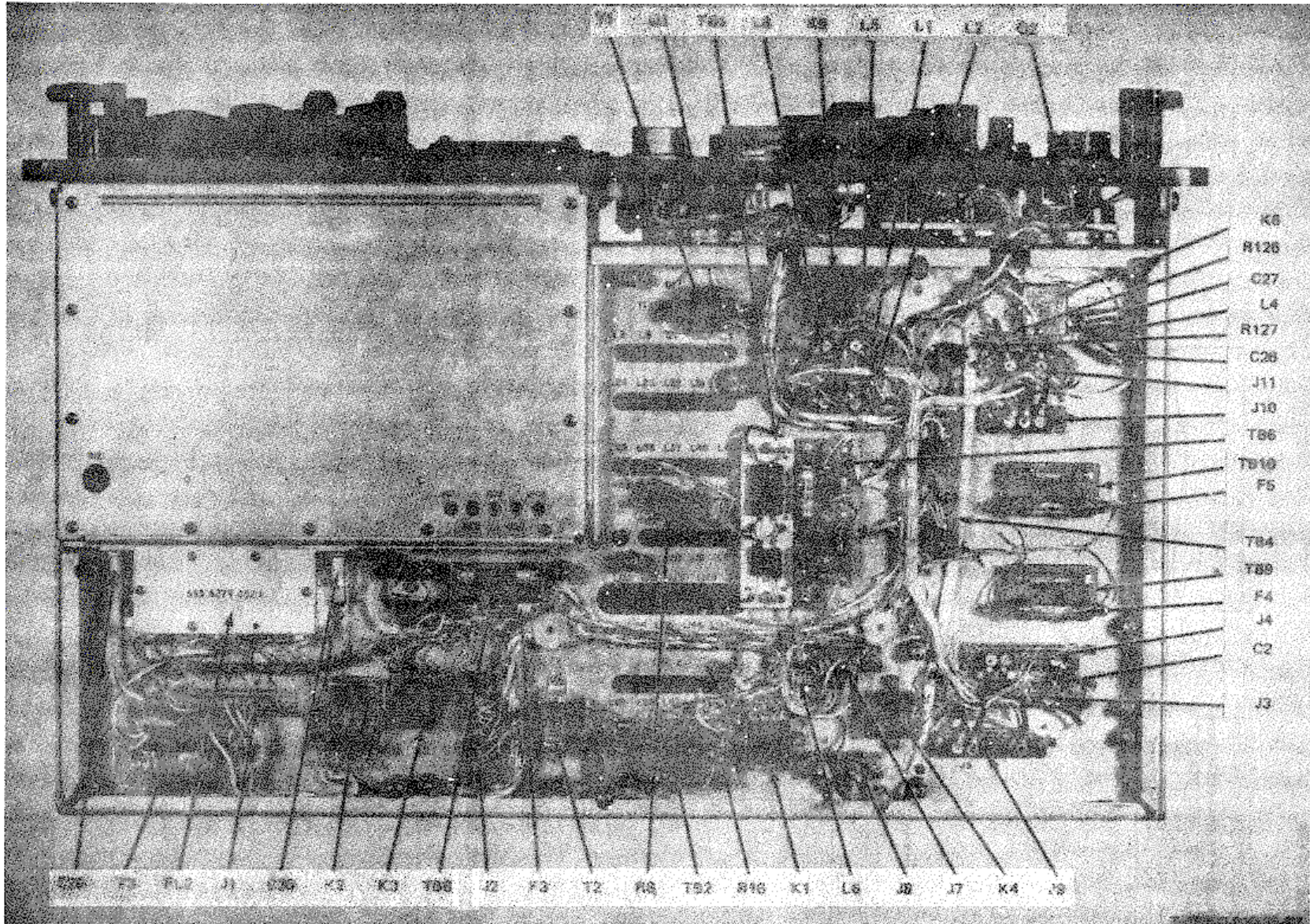

Figure 3-67. Radio Receiver Transmitter, RT 671/PRC-47 (CH-474/PRC) (A8A4), bottom view, cover removed.

DC WINDING RESISTANCES IN OHMS

K1-A TO K1-B	800
L1-1 TO L1-2	180
L2-1 TO L2-2	30
L2-2 TO L2-3	420

NOTE:
ALL TRANSISTOR VOLTAGES ARE MEASURED FROM ELECTRODE TO GROUND IN RECEIVE MODE, Q5 WITH THE TELEGRAPH KEY OPEN AND CLOSED, AND Q6 AND Q7 WITH NO AUDIO INPUT OR WITH 0.1V RMS AUDIO INPUT.

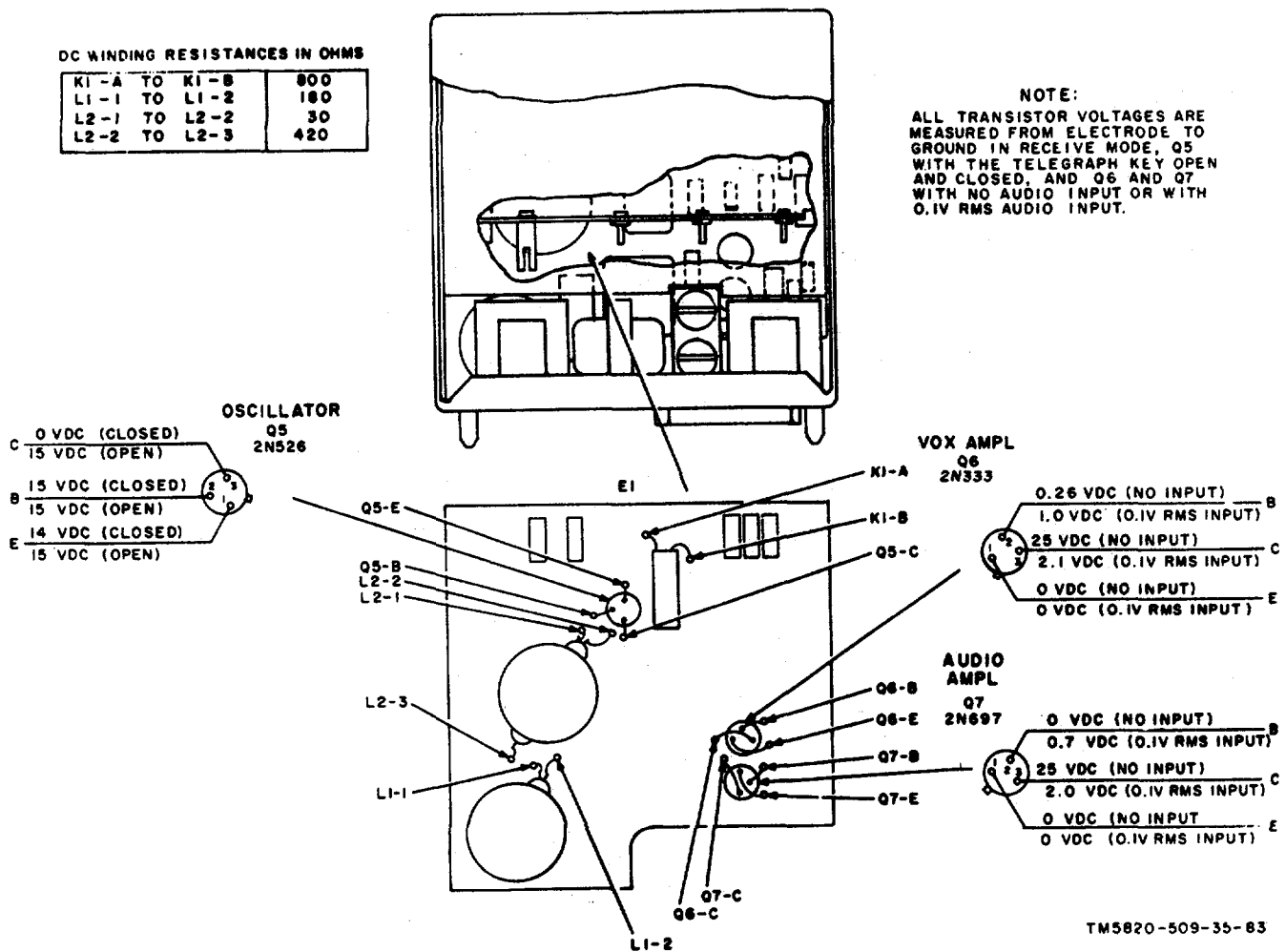

Figure 3-68. Audio Frequency Amplifier AM-3506/PRC-47 (A8A1), Subassembly E1, Voltage and Resistance Diagram.

DC WINDING RESISTANCES IN OHMS

TI-RED TO TI-BLU	400 (R12 CONNECTED)
TI-YEL TO TI-GRN	175

NOTE:
ALL TRANSISTOR VOLTAGES ARE
MEASURED FROM ELECTRODE TO
GROUND IN RECEIVE MODE WITH
NO INPUT SIGNAL.

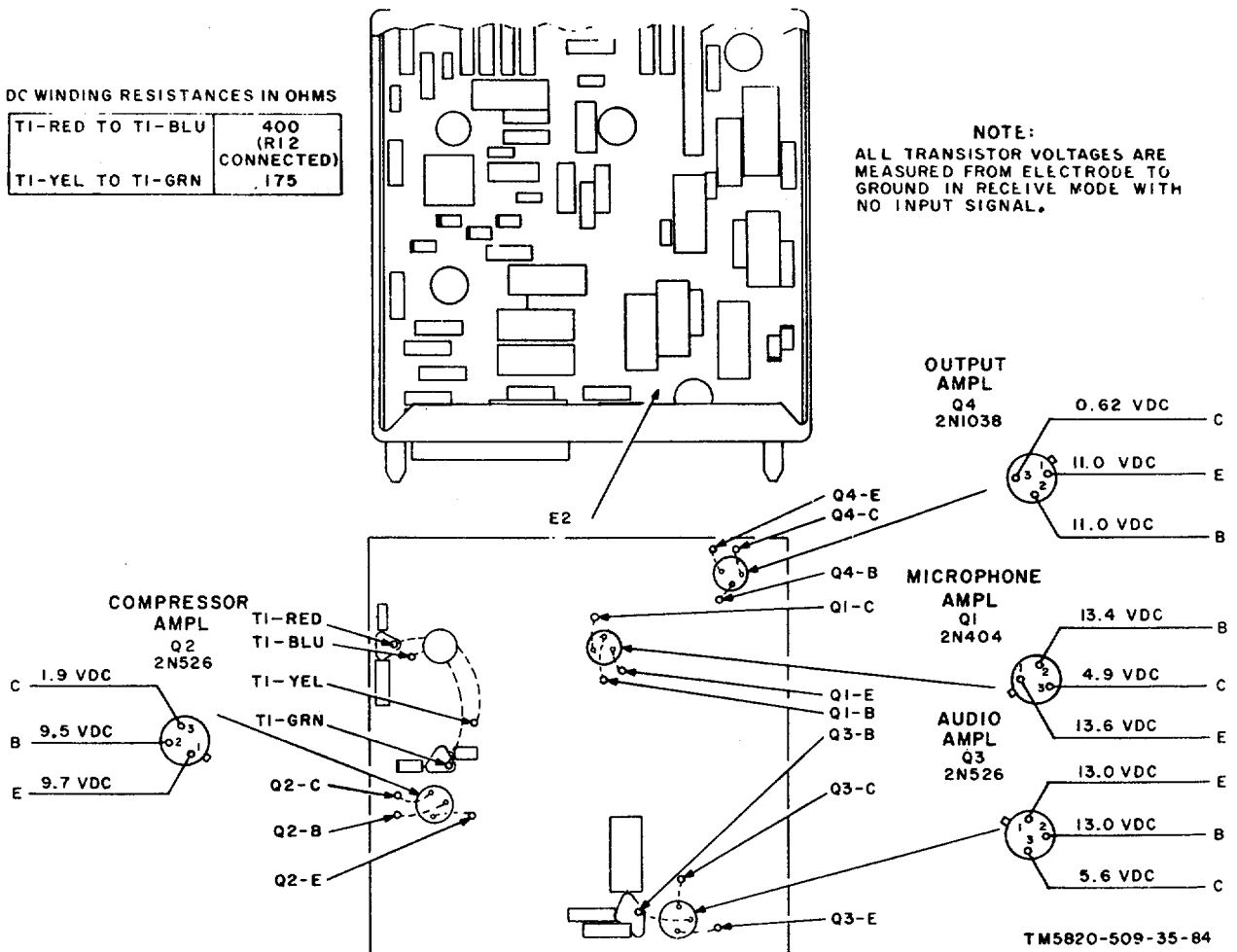

Figure 3-69. Audio Frequency Amplifier AM-3506/PRC-47 (A8A1), Subassembly E2, Voltage and Resistance Diagram.

DC WINDING RESISTANCES IN OHMS

L3-1 TO L3-2	425
--------------	-----

NOTE:

ALL TRANSISTOR VOLTAGES ARE MEASURED FROM ELECTRODE TO GROUND IN THE RECEIVE MODE WITH NO SIGNAL.

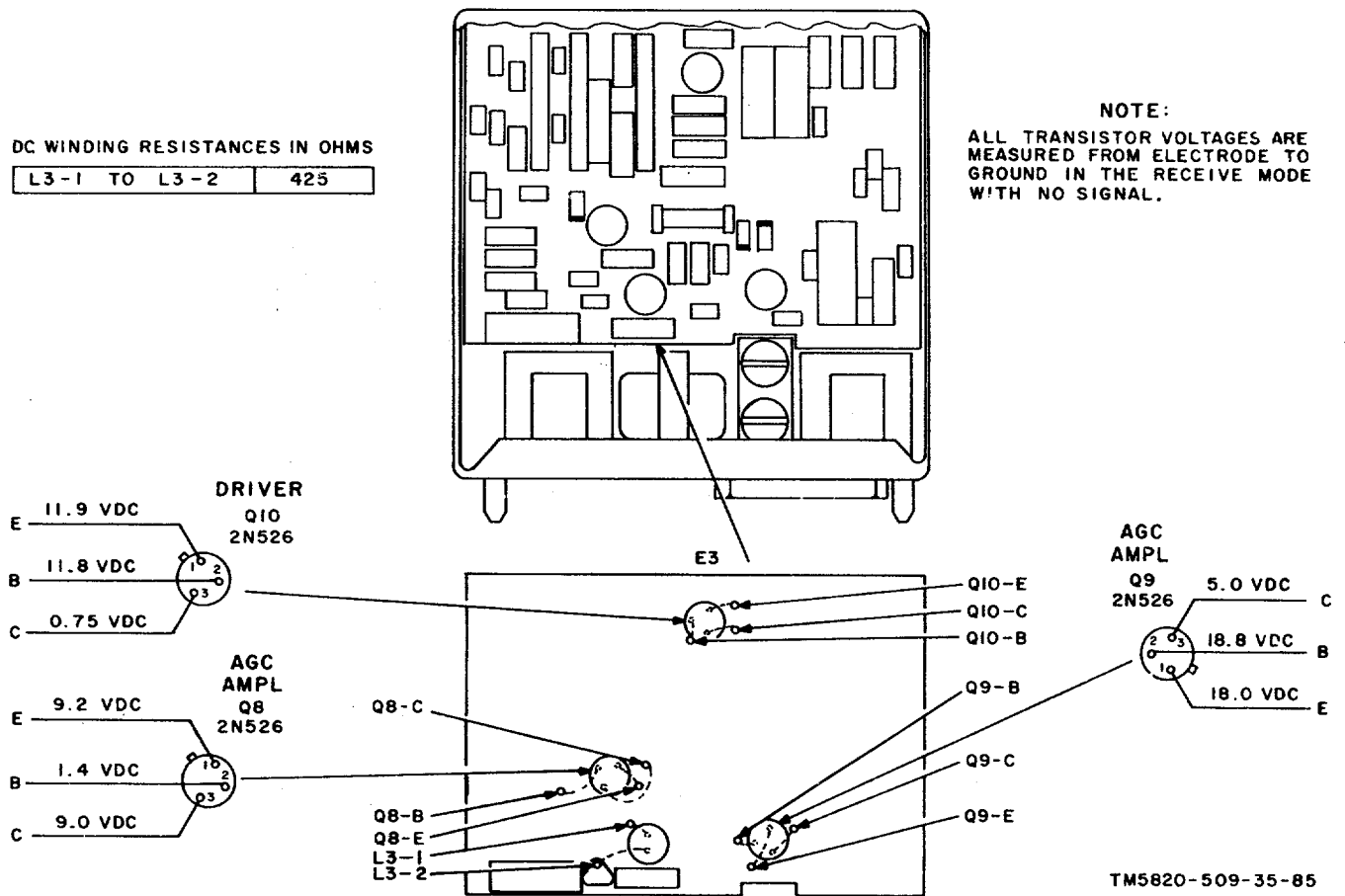
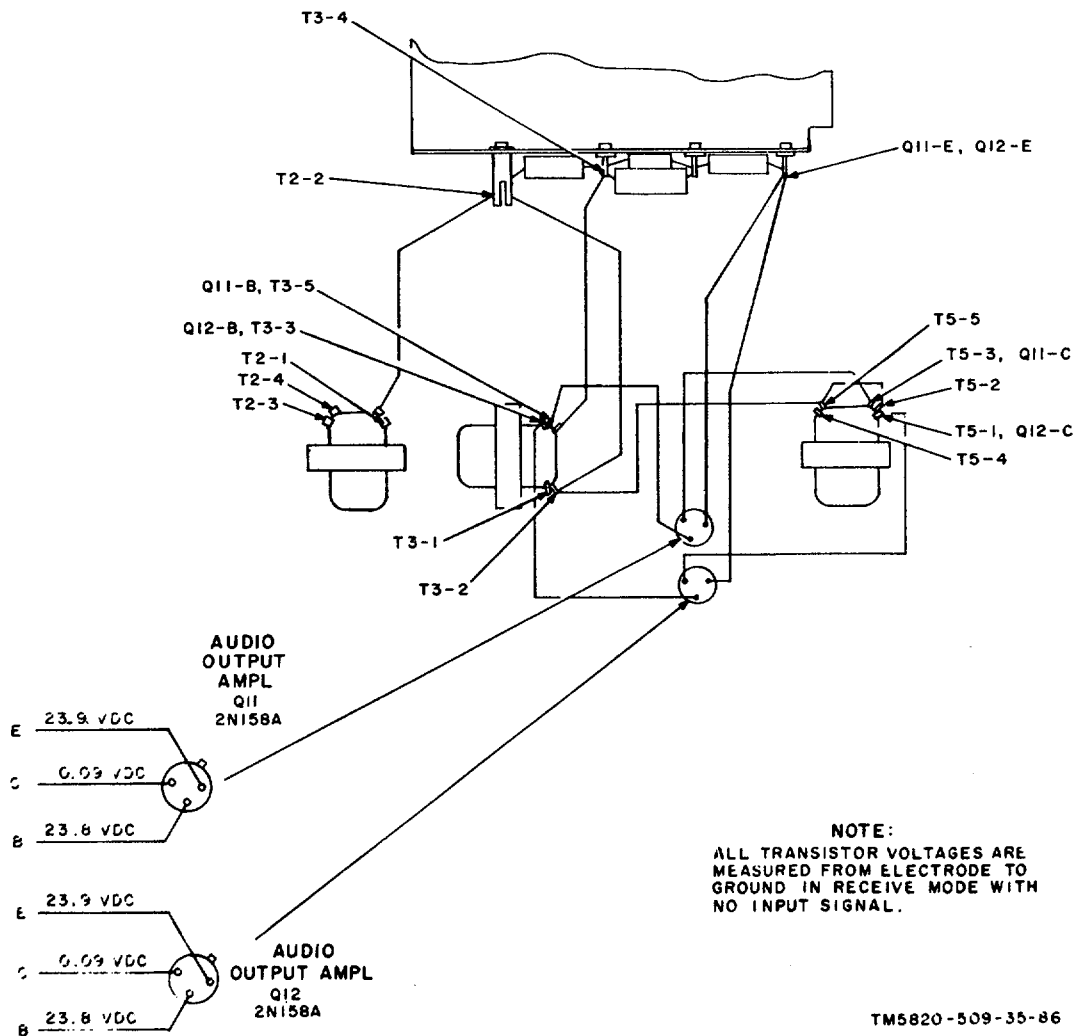
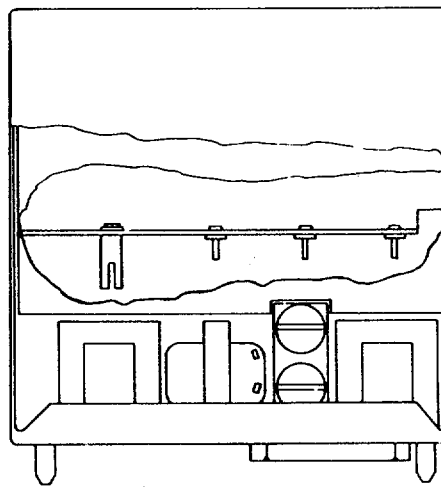

Figure 3-70. Audio Frequency Amplifier AM-3506/PRC-47 (A8A1), Subassembly E3, Voltage and Resistance Diagram.

DC WINDING RESISTANCES IN OHMS

T2-1 TO T2-2	150
T2-3 TO T2-4	15
(INFINITE WITH METER REVERSED)	
T3-1 TO T3-2	325
T3-3 TO T3-4	100
T3-4 TO T3-5	100
T5-1 TO T5-2	80
T5-2 TO T5-3	80
T5-4 TO T5-5	100



TM5820-509-35-86

Figure 3-71. Audio Frequency Amplifier AM-3506/PRC-47 (A8A1), Chassis Assembly, Voltage and Resistance Diagram.

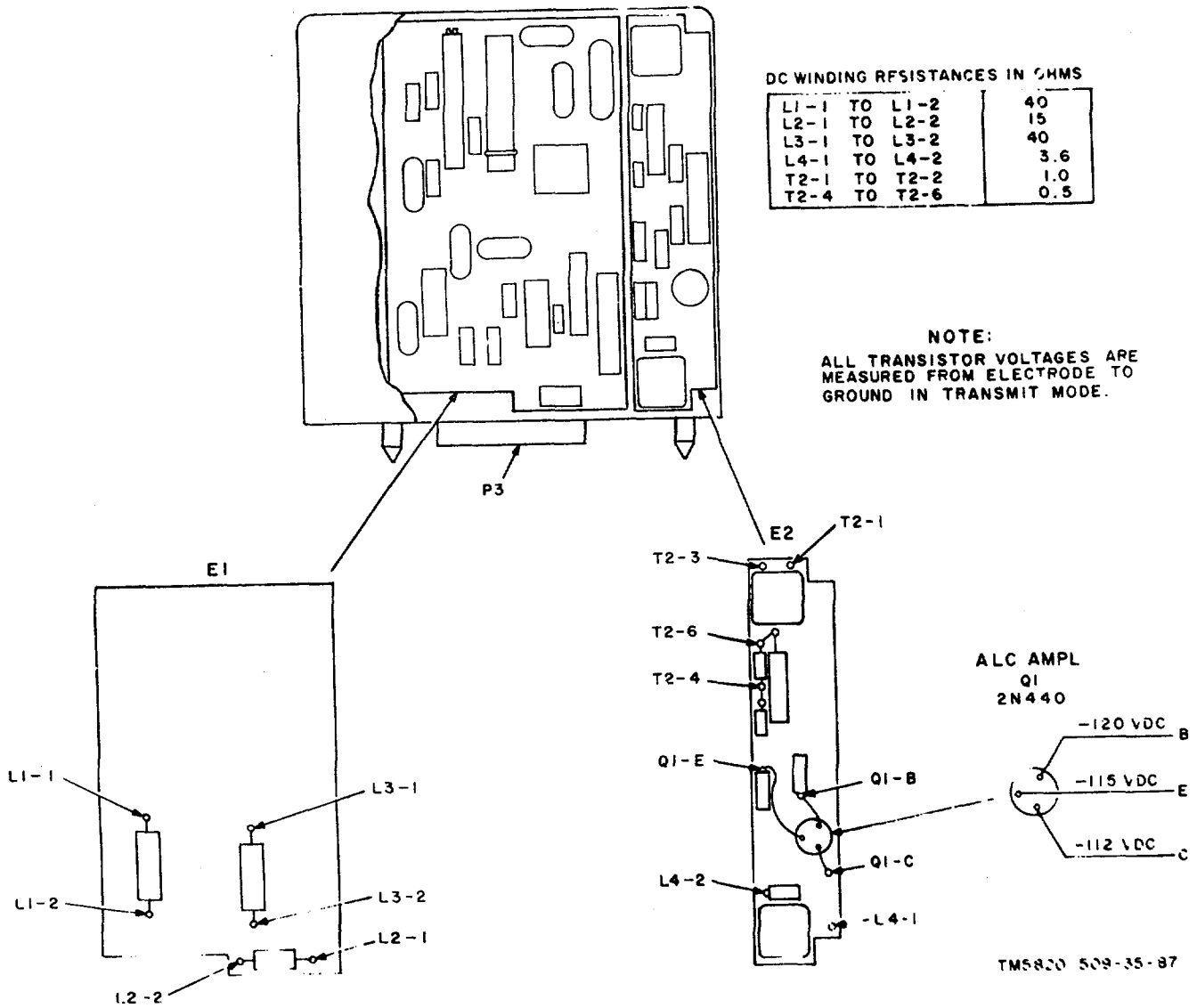

Figure 3-72. Amplifier-Modulator AM-3507/PRC-47(A8A2), Subassemblies E1 and E2, Voltage and Resistance Diagram.

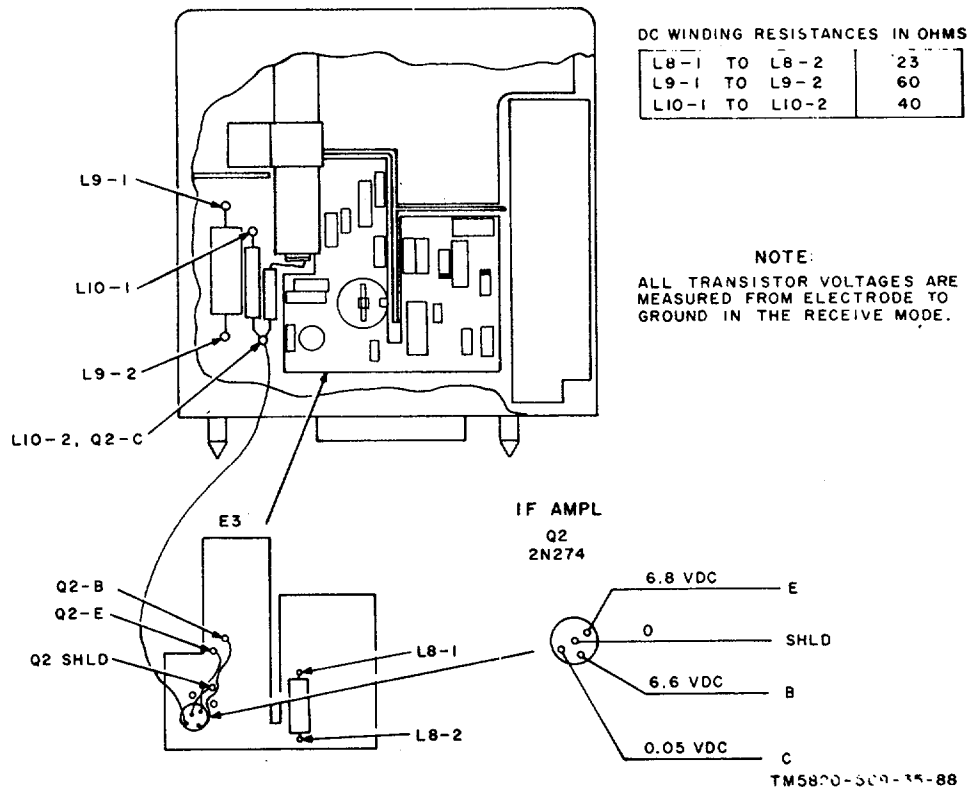

Figure 3-73. Amplifier-Modulator AM-3507/PRC-47 (A8A2), Subassembly E3, Voltage and Resistance Diagram.

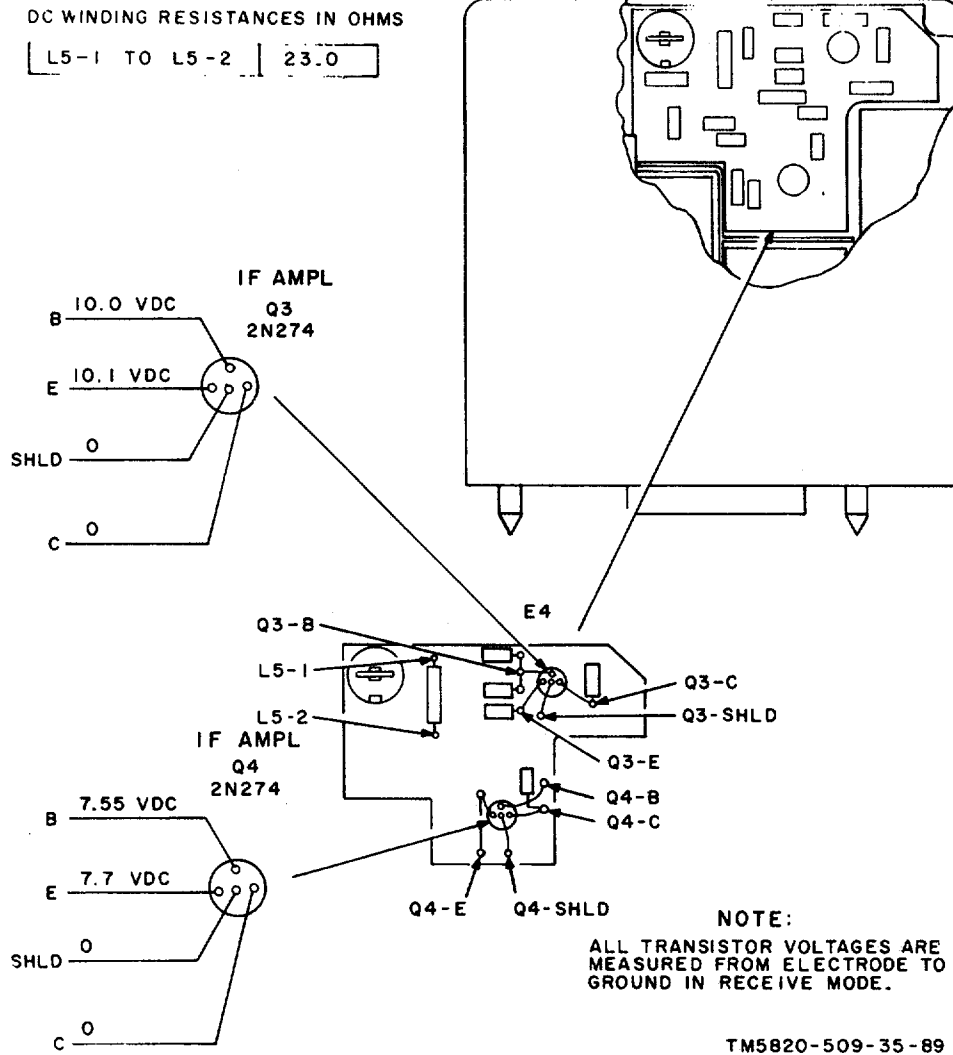

Figure 3-74. Amplifier-Modulator AM-3507/PRC-47 (A8A2), Subassembly E4, Voltage and Resistance Diagram.

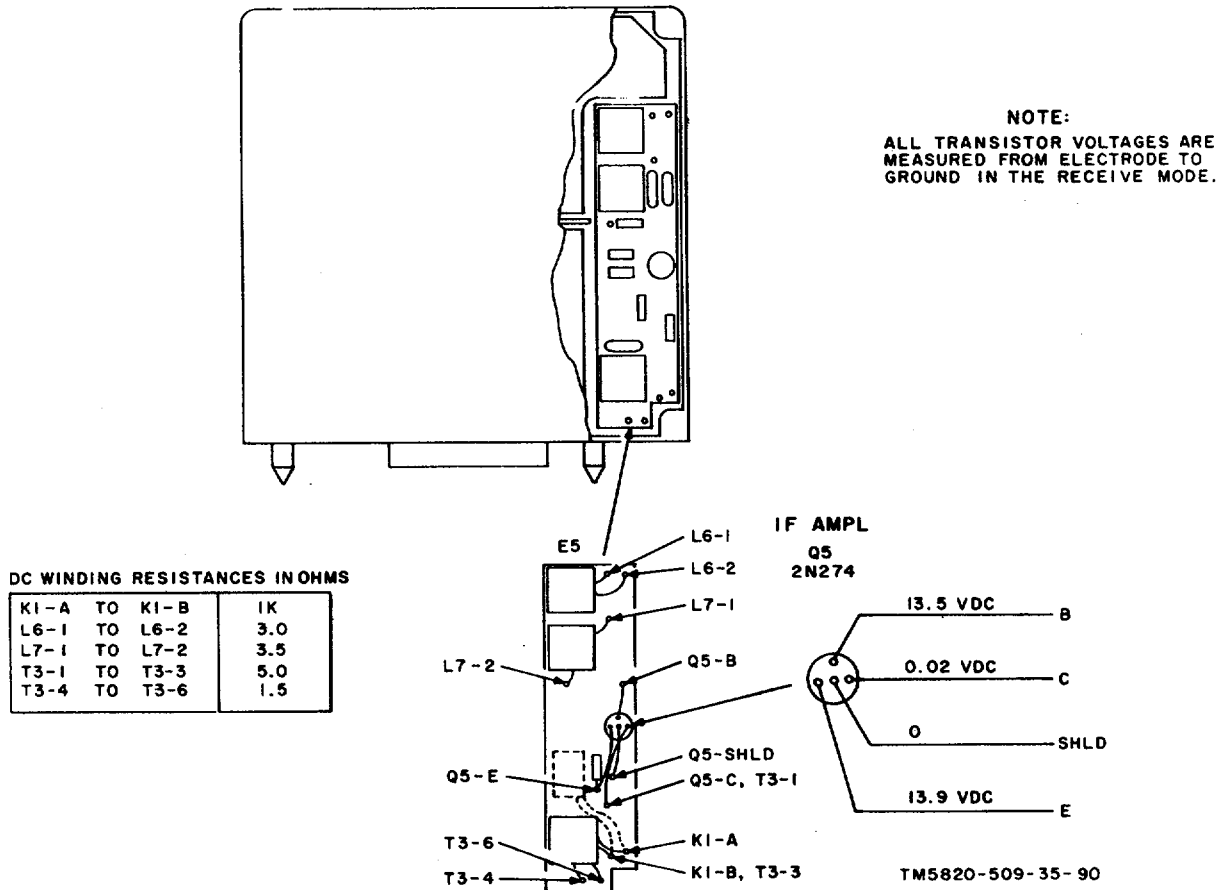

Figure 3-75. Amplifier-Modulator AM-3507/PRC-47 (A8A2), Subassembly E5, Voltage and Resistance Diagram.
3-65

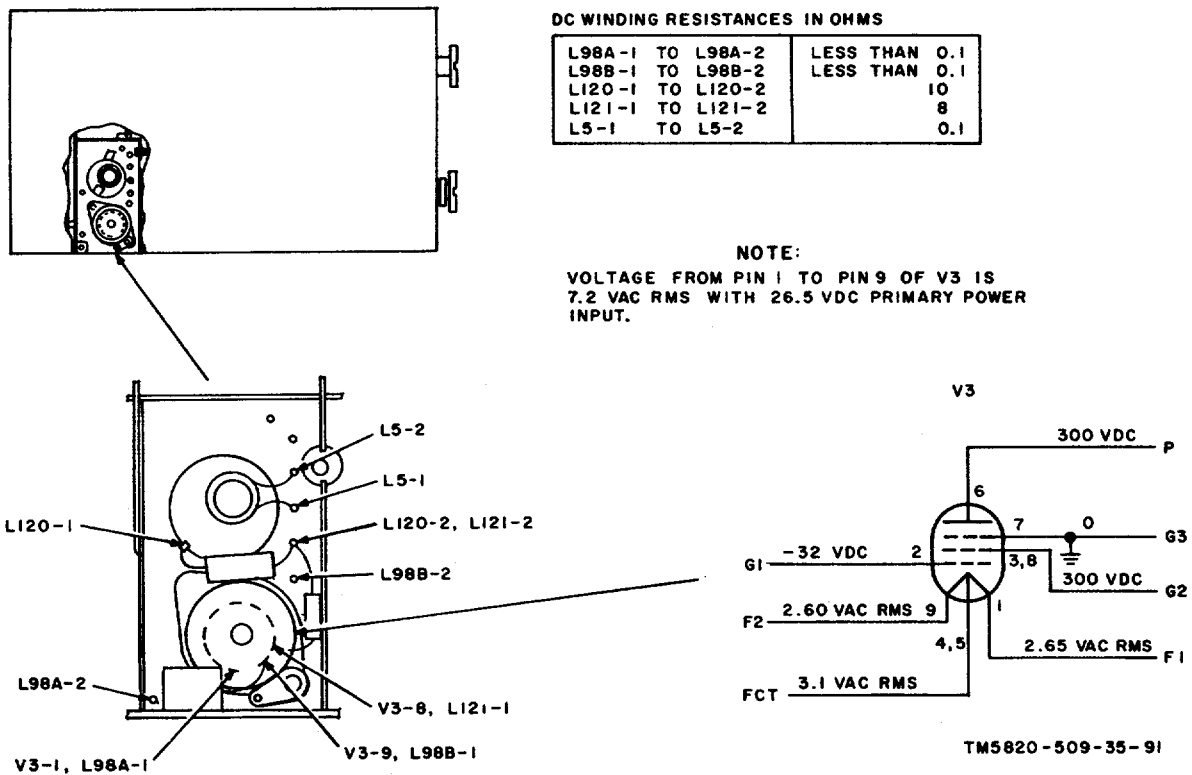

Figure 3-76. Signal Data Translator CV-1377A/PRC-47 (A8A3), Driver Tube (V3) Compartment, Voltage and Resistance Diagram.

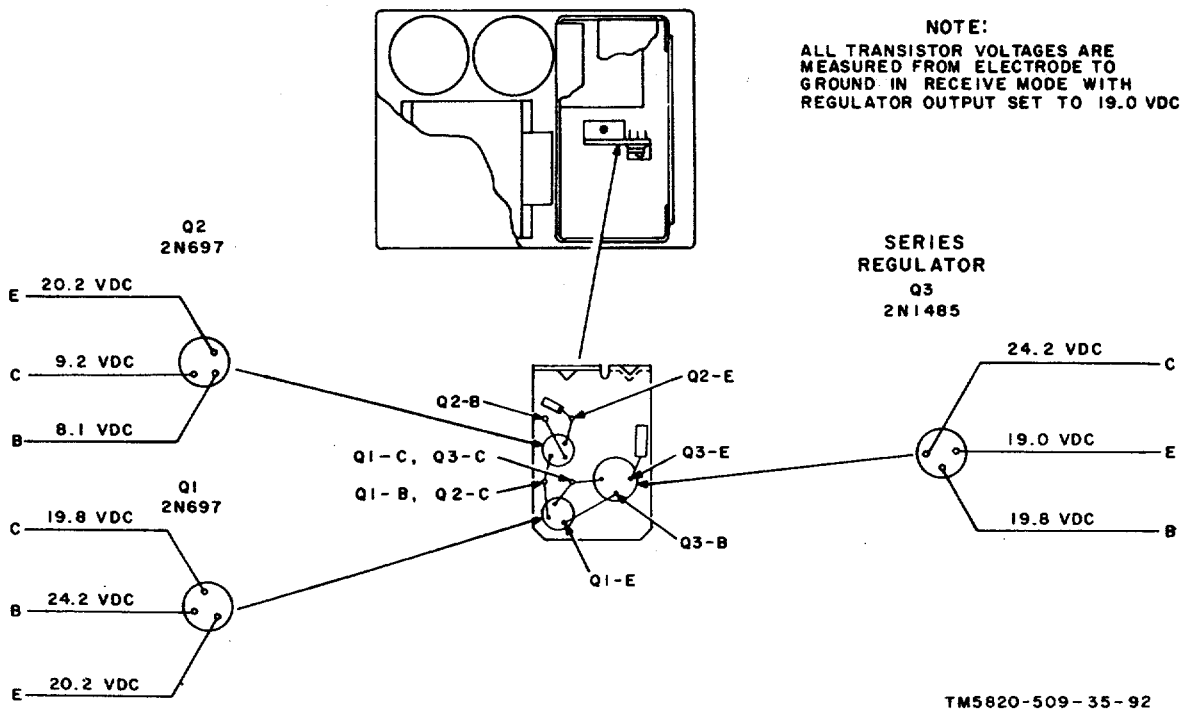

Figure 3-77. Power Supply PP-3518/PRC-47(A8A5), Voltage Regulator Assembly TB1, Voltage and Resistance Diagram.

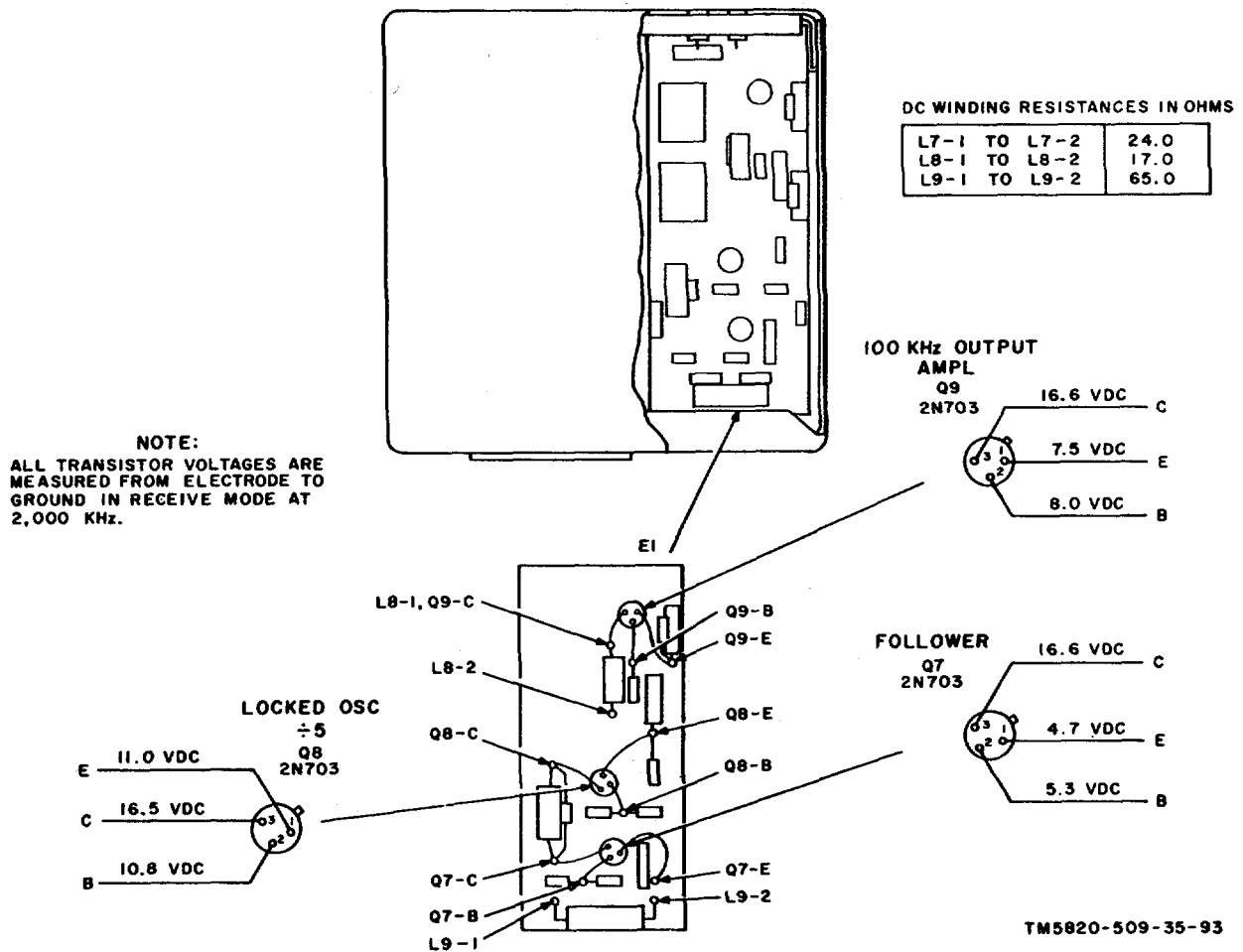

Figure 3-78. Radio Frequency Oscillator O-1032/PRC-47 (A8A6), Subassembly E1, Voltage and Resistance Diagram.

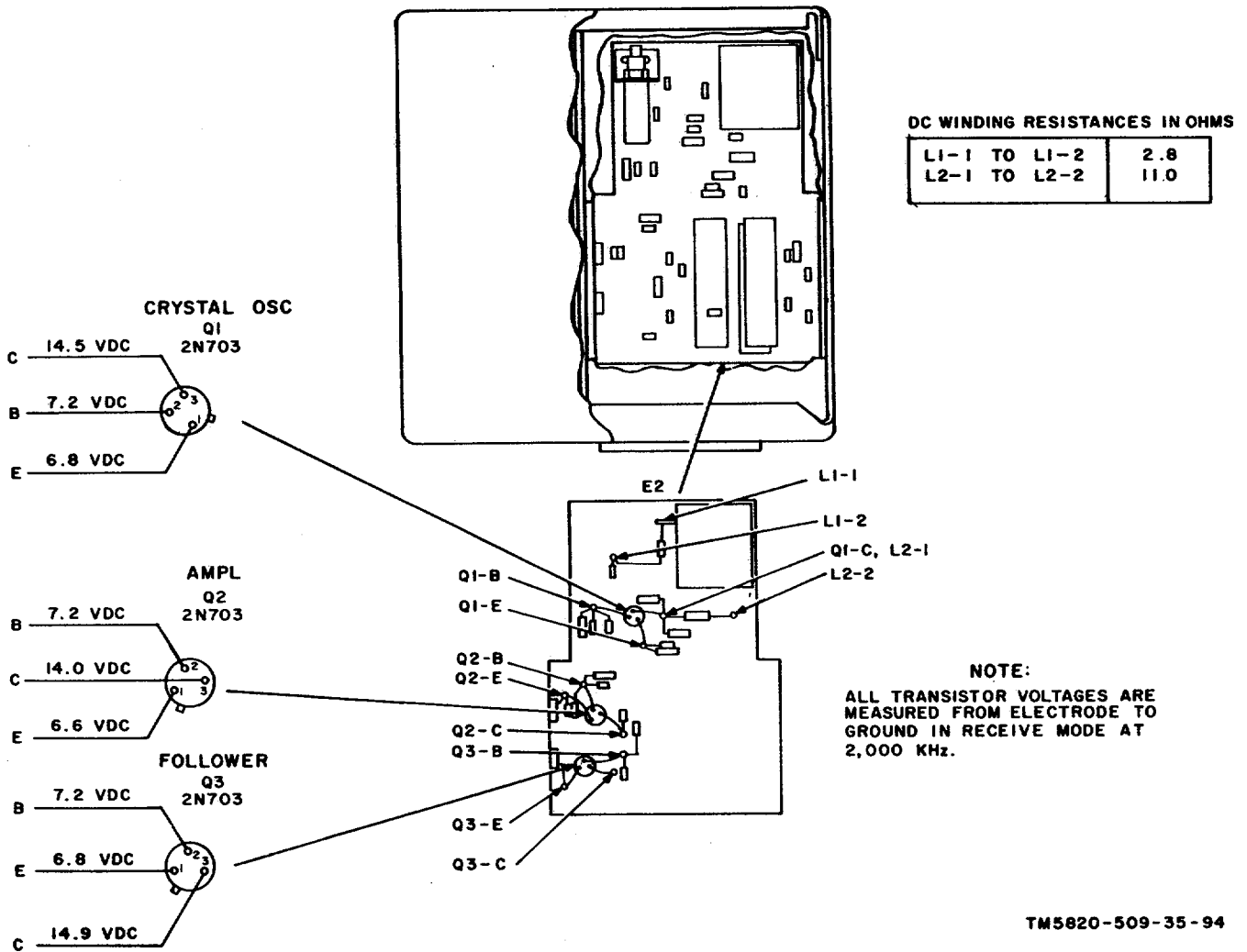

Figure 3-79. Radio Frequency Oscillator O-1032/PRC-47(A8A6), Subassembly E2, Voltage and Resistance Diagram.

DC WINDING RESISTANCES IN OHMS

L3-1 TO L3-2	6.5
L4-1 TO L4-2	16.0
L5-1 TO L5-2	4.0
L6-1 TO L6-2	60.0

NOTE:

ALL TRANSISTOR VOLTAGES ARE MEASURED FROM ELECTRODE TO GROUND IN RECEIVE MODE AT 2,000 KHz.

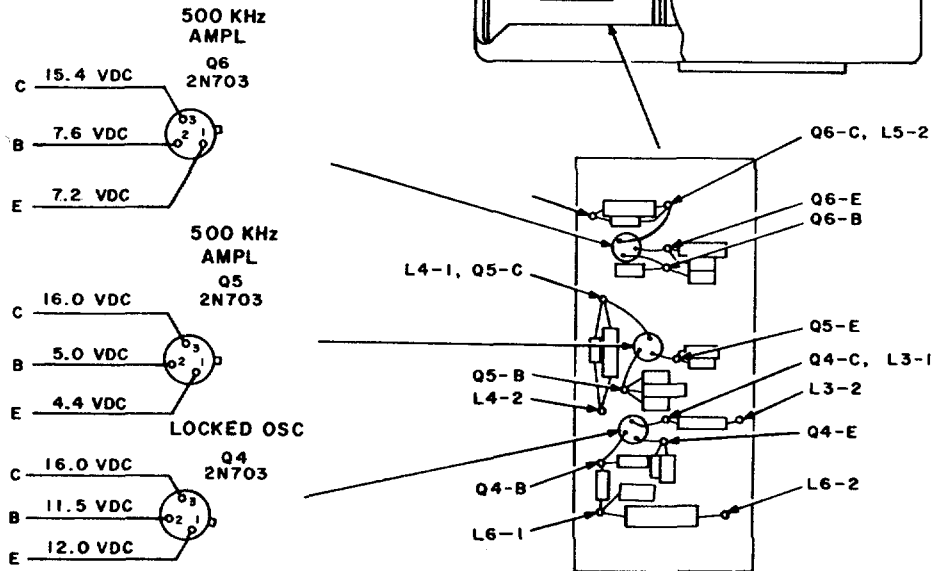

TM5820-509-35-95

Figure 3-80-. Radio Frequency Oscillator O-1032/PRC-47 (A8A6), Chassis Assembly, Voltage and Resistance Diagram.

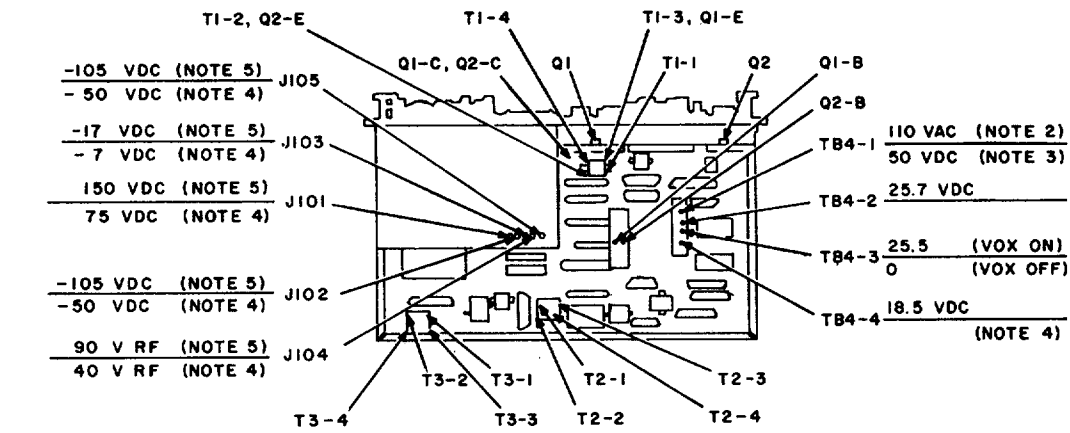

DC WINDING RESISTANCE	
TI-1 TO TI-2	0.8
TI-2 TO TI-3	0.8
TI-3 TO TI-4	0.8
T2-1 TO T2-2	80
T2-3 TO T2-4	2.2
T3-1 TO T3-2	LESS THAN 0.2
T3-3 TO T3-4	0.5

- NOTES:**
1. WITH 87.0 VOLTS RF GRID DRIVE AT 2.0 MHz THE OUTPUT IS 42.0 VOLTS RF (30.7 VOLTS MINIMUM) ACROSS THE RESISTIVE PORTION OF THE ANTENNA SIMULATOR.
 2. WITH 115 VAC PRIMARY POWER SOURCE.
 3. WITH 26.5 VDC PRIMARY POWER SOURCE.
 4. WITH VOLTAGE REGULATOR OUTPUT SET TO 19 VDC.
 5. WITH XMTR PWR SWITCH SET TO HI.
 6. WITH XMTR PWR SWITCH SET TO LO.

TM5820-509-35-96

Figure 3-81. Electrical Equipment Chassis CH-474/PRC-47 (A8), Power Oscillator Assembly, Voltage and Resistance Diagram.

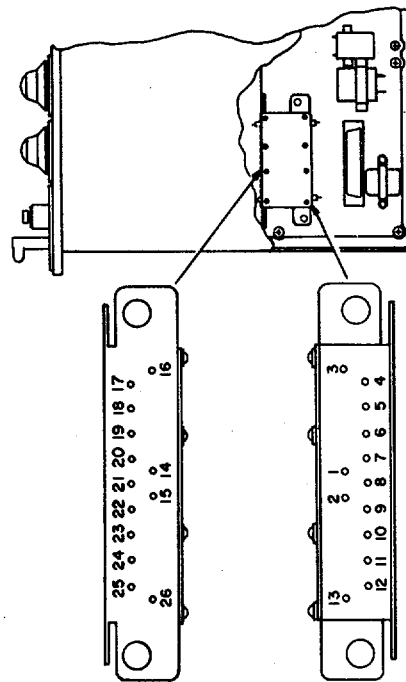

TERM NO.	RESISTANCE IN OHMS	VOLTAGE (NOTE 1)
1-14	0	7 VAC RMS (NOTE 2)
1-14	0	2.9 VAC RMS (NOTE 3)
2-15	0	7 VAC RMS (NOTE 2)
2-15	0	3.0 VAC RMS (NOTE 3)
1-2	-	7.4 VAC RMS (NOTE 2)
1-2	-	6.2 VAC RMS (NOTE 3)
3-16	24	0
4-17	24	-17 VDC
5-18	25	-105 VDC
6-19	25	-105 VDC
7-20	26	-105 VDC
8-21	2.2	19.2 VDC
9-22	20	26 VDC (NOTE 4)
9-22	-	10 VDC (NOTE 5)
9-22	-	0 (NOTE 6)
10-23	24.2	5.2 VDC RMS
11-24	24.5	0.2 VDC (NOTE 7)
11-24	-	0 (NOTE 8)
12-25	26	27 VDC (NOTE 9)
12-25	-	0
13-26	24	2.2 VDC

NOTES:

1. ALL VOLTAGES MEASURED FROM INPUT SIDE TO GROUND; IN TRANSMIT MODE EXCEPT AS NOTED.
2. WITH 26.5 VDC PRIMARY POWER SOURCE.
3. WITH 115 VAC PRIMARY POWER SOURCE.
4. WITH POWER LIGHTS SWITCH TO LIGHTS - HI.
5. WITH POWER LIGHTS SWITCH TO LIGHTS - LO.
6. WITH POWER LIGHTS SWITCH TO LIGHTS - OFF.
7. WITH M ADJ CONTROL AT MAXIMUM CLOCKWISE STOP.
8. WITH M ADJ CONTROL AT MAXIMUM COUNTER CLOCKWISE STOP.
9. RECEIVE MODE.

TM5820-509-35-97

Figure 3-82. Electrical Equipment Chassis CH-474/PRC-47, PA Filter Box FL2 (A8A4) Voltage and Resistance Diagram.

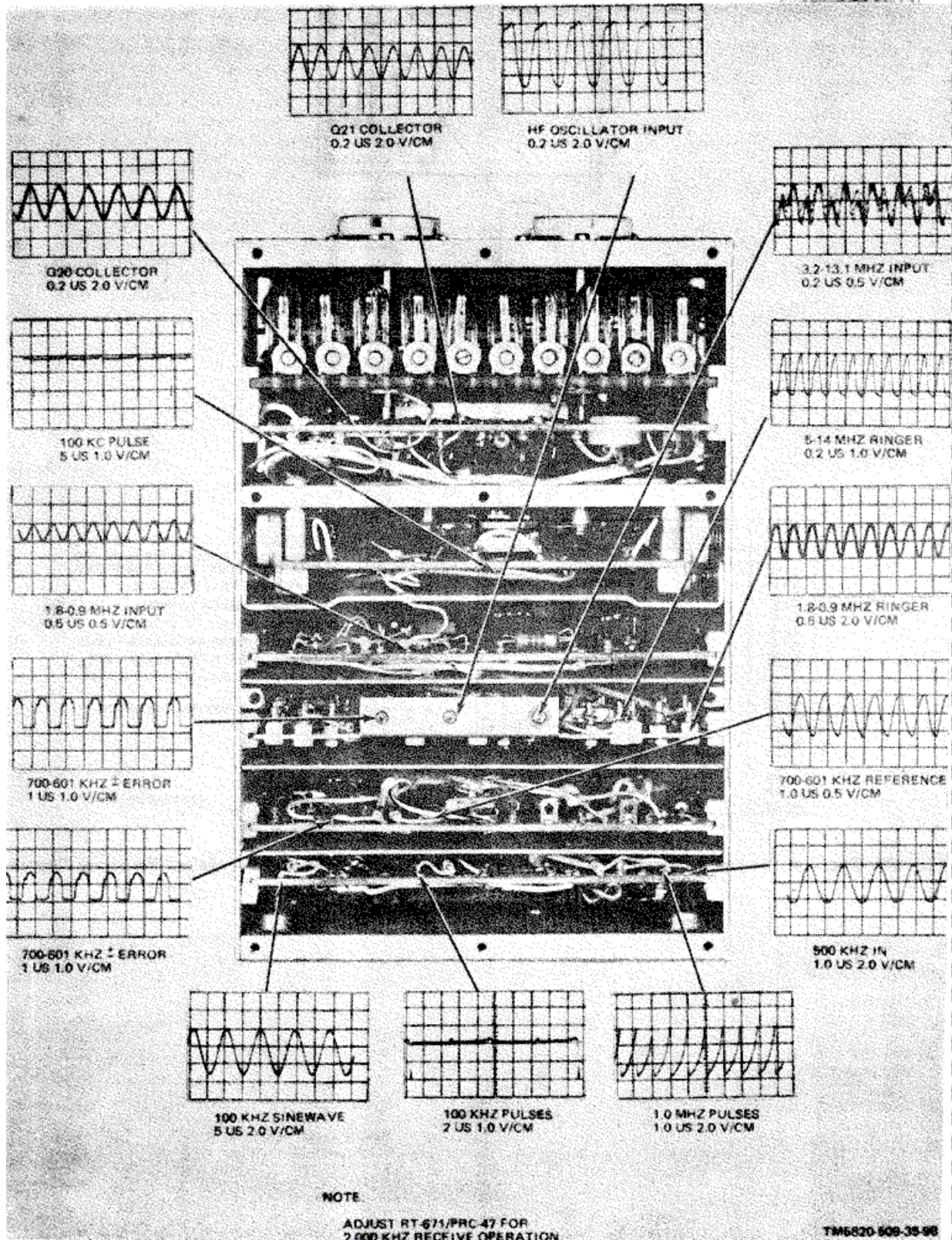

Figure 3-83. Oscillator Control C-4311 PRC-47 (A8A7), Top View, Waveform Diagram.
 3-72

b. Sectionalizing Test Settings.

(1) *General.* The extender cables and components of Cable Assembly Set AN/PRA-4 are used during the bench tests of Radio Receiver-Transmitter RT-671/PRC-47. For these tests it is not necessary to remove and extend the modular subassemblies, but the dust cover must be removed to gain access to the test points at the top of each module and beneath the power amplifier compartment. Remove the dust cover using the procedures listed in paragraph 3-11. The troubleshooting checks for the receiver portion of the equipment differ greatly from those specified for the transmitter circuits, and the test setup conditions likewise differ. Use the appropriate setup and initial procedures described in steps (2) and (3) below.

CAUTION

Do not key the transmitter unless the rf output is terminated in a 50-ohm dummy load, a quarter-wave whip, or a suitable long-wire antenna. Never key the transmitter while Signal Generator SG-103/URM-25F is connected to the ANTENNA terminal of the RT-671 /PRC-47.

(2) *Receiver Test Setup and Initial Settings* (fig. 3-2).

(a) Connect the dummy load (or a 50-ohm noninductive resistor) to the ANTENNA terminal of RT-671/PRC-47 using the antenna test lead from the AN/PRA-4.

(b) Connect the signal generator to the ANTENNA terminal.

(c) Connect the primary power source to be used to the POWER connector on the front of RT-671 /PRC-47.

(d) Connect a 300-ohm audio load to pin L of AUDIO connector on the front panel of RT-671/PRC-47; then attach multitester leads across this resistor.

(e) Set the front panel controls and the test equipment conditions as directed in the chart of paragraph 3-4 c (2).

(3) *Transmitter Test Setup and Initial Settings* (fig. 3-3).

(a) Connect the RT-671/PRC-47 ANTENNA terminal to the antenna simulator of AN /PRA-4.

(b) Connect the antenna simulator to

the dummy load using the 3-foot length of RG-58/U coaxial cable from the AN/PRA-4.

(c) Connect the multitester (with rf probe attached) to the VTVM terminals of the antenna simulator using the 5-foot length of RG-58/U coaxial cable.

(d) Connect the primary power source to be used to the POWER connector on the front of RT-671 /PRC-47.

(e) Adjust the control knobs to provide a reading of 3002 on the KILOCYCLES indicator on the front of RT-671/PRC-47; then place the CW-FSK/VOICE switch to VOICE, the XMTR PWR switch to LO, and the OPR-TUNE switch to OPR.

c. Sectionalizing Trouble. The following procedures sectionalize the malfunction to the power distribution, receiver-transmitter, frequency generation, or relay control circuits of the RT-671/PRC-47. If a specific symptom is indicated by the intermediate preventive maintenance checks and services performed at the organizational level, or by the short circuit tests of paragraph 3 4 a(4). enter the chart in that functional area; otherwise, perform all steps.

CAUTION

Do not perform these checks unless the short circuit tests indicate that further damage to the equipment is unlikely.

(1) *Preliminary Procedures.*

(a) Energize the primary power source (if separately controlled); then rotate the POWER - LIGHTS switch on the front panel of RT-671/PRC-47 to the POWER ON position.

(b) Press the BATTERY TEST switch on the front panel of RT-671/PRC-47 and observe that the XMTR OUTPUT meter reads in the banded area of its scale. {If this indication is not obtained, perform the power distribution circuit checks before proceeding further.}

(2) *Troubleshooting Chart.*

CAUTION

Do not place the CW-FSK/VOICE switch to CW-FSK in any of the following tests unless the transmitter output is properly terminated in a dummy load or a suitable antenna system. Never switch to CW-FSK when the signal generator is connected to the ANTENNA terminal.

Item	Indication	Probable trouble	Procedure
1	Multimeter at A5J7 (fig. 3-4) does not read +24 volts dc.	Popover control relay circuits of R1 or K2, or low voltage circuits of PP-3518/PRC 47 (A51 are defective.	Proceed to popover distribution circuit checks (para 3-5b).
2	Multimeter at A5J8 (fig. 3-4) does not read +20 volts dc regulated.	Low-voltage power circuits or regulator of PP-3518/PRC-47 (A5) are defective.	Proceed to power distribution circuit checks (para 3-5b).
3	Multimeter with rf probe at A3J5 (fig. 3-4) does not read 1.75 volts peak-to-peak.	Signal Data Translator CV-1377A/PRC-47 (A3) defective.	Proceed to frequency generation circuit checks (para 3-5b).
4	Frequency counter at A3J5 does not read 3502 kHz.	Signal Data Translator CV-1377A/PRC-47 (A3) defective.	Proceed to frequency generation circuit checks (para 3-5c).
<p>Place POWER-LIGHTS switch on the front of RT-671/PRC-47 to POWER OFF. Connect test equipment for receiver tests (fig. 3-2). Adjust frequency control knobs for reading of 2225 on KILOCYCLES indicator. Adjust signal generator output level to 2.0 microvolts at 2226 Hz. On RT671/PRC-47, rotate VOLUME control to maximum clockwise stop, then place POWER-LIGHTS switch to POWER ON.</p>			
5	Multimeter with rf probe at A2J3 (fig. 3-4) does not read 100 micro-volts rms.	Signal Data Translator CV-1377A/PRC-47 (A3) defective.	Proceed to receiver circuit checks (para 3-5d).
6	Multimeter with rf probe at A2J4 (fig. 3-4) does not read 1.5 volts rms.	Radio Frequency Oscillator 0-1032/PRC-47 (A6) defective.	Proceed to frequency generation and/or relay circuit checks (para 3-5c and/or 3-5f).
7	Multimeter with rf probe at A1J13 (fig. 3-4) does not read 0.1 volt rms (1000 Hz approx.)	Amplifier-Modulator AM-3507/PRC-47 (A2) defective.	Proceed to receiver circuit checks (para 3-5d).

CAUTION

Before proceeding further, disconnect signal generator and dummy load from ANTENNA terminal. Place POWER-LIGHTS switch on the front of RT-671/PRC-47 to POWER OFF. Connect the test equipment for transmitter tests (fig. 3-3). Set KILOCYCLES indicator on the front of RT-671/PRC-47 to 2000. Return POWER-LIGHTS switch to POWER ON, and tune the power amplifier as follows:

CAUTION

Do not permit the OPR-TUNE switch to remain in TUNE position for more than a few seconds at a time while the output circuit is being adjusted. Circuit damage can result.

(1) Place OPR-TUNE switch to TUNE.

(3) Return the OPR-TUNE switch to OPR.

(2) Immediately adjust POWER AMPLIFIER

Connect audio oscillator to A1J1 (fig. 3-4) and set the output level to 0.1 volt rms at 1, 000 Hz.

TUNE controls for maximum indication on XMTR OUTPUT meter.

Item	Indication	Probable trouble	Procedure
<p>CAUTION</p> <p>Do not permit CW-FSEC/VOICE switch to remain in the CW-FSK position for more than a few at a time; output circuit damage can result.</p>			
8	With CW-FSK/VOICE switch to CW-FSK, multimeter at J101 (fig 3-5) does not read +65 volts dc.	High-voltage power supply circuits of PP-3618/PRC-47 (A5) defective.	Proceed to power distribution circuit checks (para 3-5b).
9	Multitester with rf probe at antenna simulator does not read 13.7 volts rms with CW-FSK/VOICE switch at CW-FSK.	Amplifier-Modulator AM-3507/PRC-7 (A2), or amplifier stage defective.	Proceed to transmitter circuit power checks (para 3-5e).

NOTE

place CW-FSK/VOICE switch to VOICE, rotate XMTR PWR switch to Hi, and retune the output circuit to peak the XMTR OUTPUT meter readings.

Item	Indication	Probable trouble	Procedure
10	With CW-FSK/VOICE switch to CW-FSK, multimeter at J101 (fig. 3-5) - does not read +150 volts dc.	High-voltage power supply circuits of PP-3518/PRC-47 (A5) defective.	Proceed to power distribution circuit checks (para 3-5b).
11	Multimeter with rf probe at antenna simulator - not read 30.7 volts rms with CW-FSK/VOICE switch to CW-FSK.	Power amplifier circuit defective.	Proceed to transmitter circuit checks (para 3-5e).

3-5. Localizing Tests

a. *General.* The localizing tests isolate the equipment malfunction to a specific circuit on the main chassis of RT-671/PRC-47, or to a circuit within a plug-in module of the equipment. These tests are performed after the sectionalizing tests of paragraph 3-4 c, or organizational-level tests, have determined that the trouble symptom exists within a given functional area. A chart is provided for each of the following functional areas of the equipment: power distribution circuits, receiver circuits, transmitter circuits, and frequency generation circuits. The test conditions and the test equipment connections for each group of tests is detailed in its chart. Carefully observe the equipment connections and test conditions to assure that the results obtained are in agreement with the test point value specified.

b. *Power Distribution Circuit Tests.* These tests are divided into two parts: those where 115-volts, 400-Hz ac primary power is used, and those where 26.5-volts dc primary power is used. The remaining circuits (those unaffected by the type of primary power used) are listed separately.

- (1) Primary Power Source 115-volt, 400-Hz.

NOTE

Connect the test equipment for transmitter tests (fig. 3-3) and perform the initial procedures listed in paragraph 34 b (3). Unless otherwise specified, make all voltage measurements between the test point listed and chassis ground.

Item	Indication	Probable trouble	Procedure
NOTE			
Plate the POWER-LIGHTS switch on the front of RT-671 /PRC-47 to POWER ON.			
1	Ac voltage measured between test jacks A5J10 and A5J11 (fig. 3-4) is not 115 volts ac rms. Note. Do not perform this test if 26.5-volts dc primary power source is being used to power the equipment. Proceed to next chart.	<ul style="list-style-type: none"> a. Fuse F2 (POWER 5A AC) is blown or 115-volt primary power circuit is defective. b. +26.5 volts dc is not present at coil of ac power control relay K2 (terminal K2-1). c. POWER-LIGHTS switch on front panel, or associated circuit defective. d. Ac power control relay K2 coil defective. e. Contacts on dc power control relay K1 or circuit from K1 to K2 defective. f. Contacts of ac power control relay K2 are defective. 	<ul style="list-style-type: none"> a. Check and replace fuse F2 (fig. 3-87) or repair primary power circuit and/or cable. b. Check continuity of T2 primary winding from F2 holder to connector P1-L. Replace T2 if open circuit, or if shorted to chassis. Check continuity of diodes CR3 thru CR6. Replace any shorted or open diodes. c. Check continuity of circuit from K2-5 to chassis ground with POWER-LIGHTS switch at POWER ON. Repair circuit or replace switch. d. Replace relay K2 if winding resistance is not 300 ± 30 ohms. e. Check continuity of normally-closed contacts K1-2 to K1-8; replace K1 if open circuit. Check continuity from K1-8 Lo K2-4; repair circuit if open. f. Replace relay K2.
2	Dc voltage measured between A5J9 (fig. 3-4) and chassis ground is not +26.5 volts dc.	<ul style="list-style-type: none"> a. Ac primary power circuit to PP 3518/PRC-47 (A5) is defective. b. Low-voltage transformer A5T2, or its associated circuit in PP-3518/PRC-47 (A5) is defective. 	<ul style="list-style-type: none"> a. Check continuity of primary power circuit between K1-2 and connector J1-13. Repair circuit on main chassis if open circuit. b. Check continuity of A5T2 primary between J1-3 and J1-13. Repair circuit or replace PP-3518/PRC 47.

(2) Primary Power Source 26.5-volt dc.

Item	Indication	Probable trouble	Procedure
NOTE			
Place the POWER-LIGHTS switch on the front of RT-671/PRC-47 to POWER ON.			
1	<p>Dc voltage measured between A5J9 (fig. 3-4) and chassis ground is not +26.5 volts dc.</p> <p>Note. Do not perform this test if 115-volts, 400-Hz primary power source is being used to power the equipment. Use previous chart (1).</p>	<p>a. Fuse F1 (POWER 20A DC) is blown or primary power circuit is defective.</p> <p>b. +6.5 volts dc is not present at the coil of relay K1 (terminals K1-1 to K1-4.)</p> <p>c. Diode CR8 and/or R16 defective.</p> <p>d. POWER-LIGHTS switch on front panel, or associated circuit defective.</p> <p>e. Dc power control relay K1 coil defective.</p> <p>f. Contacts of K1 are defective.</p> <p>g. Dc circuit from K1 to PP-3518/PRC47 is defective.</p>	<p>a. Check and replace fuse F1 (fig. 3-87). Check continuity of input at L4; replace L4 if open. Check capacitors C26 and C27 for shorts; replace if shorted.</p> <p>b. Check continuity from F1 holder to K1-1 and K1-4, and to connector P1-J. Repair if open.</p> <p>c. Check continuity of CR8 and R16 for opens and shorts to ground. Replace defective component.</p> <p>d. Check continuity from K2-5 to chassis ground with POWER-LIGHTS switch at POWER-ON. Repair circuit or replace switch.</p> <p>e. Replace K1 if winding resistance is not $1628 \pm 10\%$ ohms.</p> <p>f. Check dc voltage at K1-7 with POWER-LIGHTS switch to POWER ON. Replace K1 if reading is zero volts.</p> <p>g. Check continuity from K1-7 to connector J1-22; and each point for short to ground. Repair as required.</p>
2	<p>Transmitter bias and high-voltage output is low or zero when 26.5-volt dc primary power input is used, but normal with 115-volt, 400-Hz primary power source.</p>	<p>a. Circuit to high-voltage transformer A5T1 in PP-3518/PRC-47 is defective.</p> <p>b. Contacts of push-to-talk relay A5K1 are defective.</p> <p>c. Circuit between J1 and power oscillator defective.</p> <p>d. Emitter circuit components defective.</p> <p>e. Base circuit components defective.</p> <p>f. Power transistors Q1 and Q2 defective.</p>	<p>a. Remove front panel power plug and check continuity from J1-14 to J1-1; repair primary circuit to A5T1 or replace transformer.</p> <p>b. Check voltage at A5K1-5 with ptt relay operated: (normal +26.5 volts dc). Replace A5K1 if no voltage present.</p> <p>c. Check continuity of power cable jumpers (pins A-B, C-D, and J-K) and circuits from J1-1/J1-2, J1-14/J1-15, and J1-16/J1-17; repair circuit or replace cable. Check continuity from P1-A to Q2 emitter, and from P1-C to Q1 emitter; repair circuit if open.</p> <p>d. Check continuity of C1, CR1, CR2, and R5 for opens and shorts: replace defective component.</p> <p>e. Check continuity of R1 through R4: replace defective component. Check winding of reactor for opens: normal readings are T1-1 to T1-2, 1.0 ohm; T1-2 to T1-3, 60 ohms; T1-3 to T1-4 1.0 ohm; replace T1 if defective.</p> <p>f. Replace with proper type number.</p>

(3) Power Distribution Circuits and Components

Item	Indication	Probable trouble	Procedure
1	XMTR OUTPUT meter M101 does not read in the banded portion of its scale when BATTERY TEST switch is pressed.	<ul style="list-style-type: none"> a. +26.5-volt dc lamp circuit defective. b. Resistor R23 defective. c. BATTERY TEST switch S2 (fig. 3-87) defective. d. PA filter box FL2 (fig. 3-5) defective. 	<ul style="list-style-type: none"> a. Check continuity from K1-7 to POWER-LIGHTS switch S1-6: to antilock relay K6- 1, to inductor L3, and resistor R23. Repair circuit as required. b. Check resistance of R23 (normal 681K ohms). Replace if defective. c. Check continuity from R23 to S3A (NO) to S3A (COM) with switch pressed: replace S3 if defective. d. Check continuity from S3A (COM) to FL2-11. Repair circuit if open. Check resistance between FL2-11 and FL2-24 (normal 29.0 ohms). Repair FL2 if abnormal reading.
Caution:			
Before continuing this procedure, disconnect the lead from the positive (+) terminal of XMTR OUTPUT meter M101. Do not attempt to measure the meter movement resistance.			
		<ul style="list-style-type: none"> e. PA filter box circuit shorted to ground. f. Meter bypass circuit defective. 	<ul style="list-style-type: none"> e. Check for short to ground at FL2-11 and FL2-24. Repair circuit C216, C203, L203, as required. f. Check continuity from FL2-24 to lead removed from + meter terminal. Repair if open. Check C107 for short; replace if necessary.
Note:			
Reconnect the positive (+) meter lead removed above before proceeding to the next procedural step.			
2	Panel lamps in main compartment (DS1 and DS2) (fig. 3-87) fail to light when POWER-LIGHTS switch is rotated to LIGHTS HI.	<ul style="list-style-type: none"> g. XMTR OUTPUT meter defective. a. Panel lamps DS1 and DS2 burned out. b. Lamp circuit defective. 	<ul style="list-style-type: none"> g. Remove and replace M101. a. Replace burned out lamp bulbs. b. Check continuity from S1-10 to each lampholder; check continuity from each lampholder to ground. Repair any defective circuits. c. Replace switch S1.
3	Panel lamps in power amplifier compartment (DS101 and DS102) (fig. 3-87) fail to light when DS1 and DS2 are lighted.	<ul style="list-style-type: none"> c. POWER-LIGHTS switch (lamp circuit) defective. a. Panel lamps DS101 and DS102 are burned out. b. Lamp circuit defective. c. PA filter FL2 (fig. 3-5) defective. d. Lampholder or circuit to FL2 defective. 	<ul style="list-style-type: none"> a. Replace burned out lamp bulbs. b. Check continuity from S1-10 to FL2-9; repair circuit if defective. c. Check resistance from FL2-9 to FL2-22 (normal 29 ohms). Repair circuit C218, C229, C206, and L205 as required. d. Check continuity from FL2-22 to each lampholder, and from each lampholder to ground. Repair any defective circuits or replace lampholder.
4	Panel lamps remain bright or go out when POWER-LIGHTS switch is rotated to LIGHTS LO.	Dimming resistor R6 is defective.	Check resistance of R6 (normal 180 ohms; replace if necessary). Check continuity from S1-9 to S1-6; replace S1 if defective.

Item	Indication	Probable trouble	Procedure
5	Dc voltage measured between A5J7 (fig. 3-4) and chassis ground is not +24 volts dc.	Low-voltage power supply, filter, or voltage regulator defective.	Perform isolation procedures on PP-3518/PRC-47 (see para 3-6).
6	No receive audio output or low and distorted output from headset.	a. +24-volt circuit between J1-19 and J2-9 defective. b. Audio frequency amplifier AM-3506/PRC.47 defective.	a. Check continuity from J1-19 to J2-9: repair open circuit. b. Repair or replace AM-3506/PRC-47 (para 3-6).
7	Dc plate and Wren voltage at 1 st - and 2d- rf amplifiers in signal data translator not present.	a. +24-volt circuit between J1-19 and J5-5 defective. b. Signal Data Translator CV-1377A/PRC-47 (A3) defective.	a. Check continuity from J1-19 to K3-6: from K3-6 to K3-4; from K3-4 to L5: and from L5 to J5-5. Check resistance of L5 (normal 72.0 ohms): repair circuit or replace K3 or L5 if required. b. Repair or replace CV-1377A/PRC-47 (para 3-6).
8	Dc voltage measured between A5J8 (fig. 3-4) and chassis ground is not +20 volts dc regulated.	Low-voltage power supply, filter, or voltage regulator defective.	Perform isolation procedures on PP-3518/PRC-47 (A5) (para 3-6) or replace power supply.
9	20 volts dc is not present at receiver circuits.	a. Fuse F3 (½ A) (fig. 3-5) is burned out. b. 20-volt circuit from power supply A5 to receiver circuits is defective.	a. Check and replace fuse F3. b. Check continuity from F3 to each circuit: (J2-13, J4-3, J5-3, J8-1, J9-1, J11-1, K3-8, K3-2, L1, and J5-1). L1 resistance is 1.2 ohms. Repair circuit or replace K3 or L1 if defective.
10	Dc plate and screen voltage at V3 not present.	a. Fuse F5 (1/10A) (fig. 3-5) is burned out. b. 300-volt circuit between J1-21 and J7-2 or KC3-7 defective.	a. Check F5 and replace fuse. b. Check continuity from J1-21 to F5, from F5 to J7-2 and to R8. (R8 normal 4,750 ohms). Check continuity from R8 to K3-7. Repair circuit or replace R8 if defective.
11	Filaments of rf amplifiers V1 and V2, and driver V3 in signal data translator A3 do not light.	a. Filament circuit of vacuum tube(s) open. b. Filament winding of high-voltage transformer A5T2 defective. c. Filament circuit between J1-5 and T3-1, or J1-4 (or J1-8) and T3-2 and relay K2 is defective. d. Filament transformer T3 defective. e. Signal data translator A3 defective.	a. Check filament circuit in each tube for continuity. Replace defective vacuum tube. b. Voltage test-Measure at A5J3 to A5J4 with 115-volt ac primary power input; normal 6.3 vac rms. (with 26.5 volt dc primary power input, reading from A5J3 to J5-4 is 6.3 vac <i>peak</i> . Replace T2 if winding defective. c. Check continuity from J1-5 to T3-1 and to FL2-1: from J1-4 to K2-2, to K2-8, to T3-2, and FL2-2 for open circuits or short to ground. Repair circuit, or replace relay K2 if defective. Check continuity from J1-8 to K2-3 and repair if required. d. Check resistance of primary (normal 0.75 ohms) and secondary (normal 0.75 ohms). Replace if defective. Check continuity from T3 secondary to J7-3 and J7-4. Repair if open. e. Repair or replace CV-1377A/PRC-47 (para 3-6).

Item	Indication	Probable trouble	Procedure
12	Filaments of power amplifier stage do not Light.	a. Filament circuit vacuum tube open. b. Filament chokes L120 and L121 defective.	a. Check continuity of filament circuit within V101; replace tube (para 3-14) if defective. b. Check continuity of chokes L120 and L121 (normal 0.09 ohms). Replace if defective.
Note. Make the following checks after unsoldering the filament lines from PA filter box FL2-14 and FL2-15. (Tag each wire).			
		c. Filament circuit in FL2 defective.	c. Check continuity from FL2-1 to FL2-14 and from FL2-2 to FL2-15, and test each terminal for shorts to ground. Repair circuit or replace C221, C208, C235, C220, C207, or C234 if defective.
Note: Reconnect the two filament lines to terminals FL2-14 and FL2-15 of the PA filter box.			
		d. Filament bypass capacitors or hum balance resistor or circuit defective.	d. Check continuity of R121 (normal 50 ohms); check continuity of circuit from L120 to XV101-1 and L121 to XV101-7. Repair circuit, or replace R121 if defective.
Note. Disconnect capacitors C103 and C104 from XV101 before proceeding with the following tests. (Tag each lead).			
		e. Filament bypass capacitors shorted to chassis ground.	e. Check C103 and C104 for shorts; replace if defective.
Note. Reconnect capacitors C103 and C104 to the filament pins of tube socket XV101.			
13	Dc bias voltage measured between A3J3 and chassis ground is not -25 volts dc.	a. -32-volt dc bias circuit of PP-3518/PRC-47 incorrectly adjusted or defective. b. Fuse F4 (1/500A) (fig. 3-5) is burnt out. c. Inductor L6 is open or shorted to ground. d. -32-volt bias circuit on main chassis defective. e. -32-volt bias circuit in signal data translator A3 defective.	a. Perform adjustment routine of paragraph 3-27, replace PP-3518/PRC-47, or repair (para 3-6) if defective. b. Check and replace fuse F4, if defective. c. Check continuity of L6 (normal 72.0 ohms); check L6 for shorts to ground. Replace L6 if defective. d. Check continuity from J1-23 to XF4-1, from XF4-2 to L6-1, from L6-2 to J7-1. Repair as required. e. Repair CV-1377A/PRC-47 using procedure of paragraph 3-6.
14	Dc bias voltage measured between J102 (fig. 3-5) and chassis is not -110 volts dc.	a. -110-volt dc bias circuit of PP-3518/PRC-47 incorrectly adjusted or defective. b. XMTR PWR switch S103 not at HI position. c. XMTR PWR switch S103 defective.	a. Perform adjustment routine of paragraph 3-27, replace PP-3518/PRC-47, or repair (para 3-6) if defective. b. Place S103 to XMTR PWR HI. c. Check continuity of S103 (in HI position) from S103-1 to S103-4 or S103-5. Rotate S103 to LO position and check from S103.1 to S103-2. Measure resistance of R107 (normal 100K ohms). Repair circuit or replace S103 or R107 as required.

Item	Indication	Probable trouble	Procedure
		<p>d. -110-volt dc bias circuit in PA filter box FL2 defective.</p> <p>e. -110-volt bias circuit between J1-9 and FL2-7 defective.</p> <p>f. -110-volt bias circuit between S103 and J102 defective.</p> <p>g. J102 circuit defective.</p>	<p>d. Rotate XMTR PWR switch to OFF and check continuity from FL2-7 to FL2-20 (normal 29 ohms); check for shorts to ground. Replace C222, C209, C233, or L201 as required or repair circuit.</p> <p>e. Check continuity from J1-9 to FL2-7; repair as required.</p> <p>f. Check continuity from S103-1 to L102; repair circuit if necessary. Check C101B for shorts; replace if necessary.</p> <p>g. Check continuity from J102 to S103-1 (normal 10K ohms). Replace R103 or J102 as required.</p>
WARNING.			
The 650- and 1600-volt potentials at the power amplifier screen and plate electrodes are extremely dangerous. Avoid contact with these circuits.			
15	Plate and screen voltages to power amplifier stage is low or not present.	<p>a. +650-volt screen circuit defective.</p> <p>b. Capacitor C30 shorted to ground.</p> <p>c. Switch S103 defective.</p> <p>d. Screen grid voltage divider defective.</p> <p>e. Screen grid circuit from S103B-10 to power amplifier socket defective.</p> <p>f. Screen voltage relay K102 filter network defective.</p> <p>g. Plate circuit from S103A-3 to power amplifier plate electrode defective.</p>	<p>a. Check continuity of screen circuit from J1-A1 to C30, from C30 to L123-1, from L123-2 to S103A-5, to S103B-3. Repair circuit if open.</p> <p>b. Check C30 for short to ground; replace if necessary.</p> <p>c. With XMTR PWR switch at LO, check continuity from S103A-3 to S103A-5; from S103B-10 to S103B-11. Rotate XMTR PWR switch to HI and check continuity from S103A-3 to S103A-8 and from S103B-3 to S103B-10. Replace S103 if defective.</p> <p>d. With XMTR PWR switch at HI, or OFF, check resistance between S103B-11 and S103B-3 (normal 50K ohms) and between S103B-11 and chassis ground (normal 100K ohms). Replace R105, R106, and/or R128 if defective.</p> <p>e. Check continuity from S103B-10 to K102-7, from K102-8 to K102-4, and from K102-3 to L103-1. Resistance of L103 is 50 ohms. Check continuity from L103-2 to XV101-2 and XV101-6. Check C139 for short to ground. Repair circuit or replace L103 or C139 if defective.</p> <p>f. Check continuity across C146 and measure resistance of R125 (normal 560 ohms). Replace C146 if shorted and R125 if defective.</p> <p>g. Check continuity from S103A-3 to R112, to L106-1, from L106-2 to L109-1, and from L109-2 to V101 plate cap. Measure resistance of L106 (normal 2.1 ohms) and L109 (normal less than 1 ohm) and check C123 for short to ground. Repair circuit, or replace C123, L106, L104 /R110, or TUNE coil L109.</p>

Item	Indication	Probable trouble	Procedure
		<p><i>h.</i> Shorted capacitor in power amplifier plate circuit.</p> <p><i>i.</i> Plate voltage circuit in main chassis defective.</p>	<p><i>h.</i> Check continuity of L105 (normal 3.2 ohms) and verify that none of the plate tank capacitors is shorted: replace L105, C105, C108 thru C122 if defective.</p> <p><i>i.</i> Check continuity from S103A.8 to L122-1, from L122-2 to C29, and from C29 to J1-A2. Resistance of L122 is 11.6 ohms. Repair circuit or replace defective component.</p>

c. Frequency Generation Circuit Tests. Perform the following procedures in the order listed for isolation of malfunctions to a module within the frequency generation and control circuits.

Item	Indication	Probable trouble	Procedure
1	<p>Place the POWER LIGHTS switch on the front panel of RT -671/PRC 47 to POWER OFF. Connect the test equipment for receiver tests (fig. 3 2). Adjust the frequency control knobs for a reading of 2225 on the KILOCYCLES indicator; adjust the signal generator for 2.0 microvolts output at 2226 kHz. Rotate the VOLUME control on the front of RT-671/PRC-47 to its maximum clockwise stop and then place POWER-LIGHTS switch to POWER ON</p> <p>No signal, or erratic operation at selected frequency.</p>	<p><i>a.</i> Hf oscillator circuit in signal data translator A3 defective.</p> <p><i>b.</i> Hf oscillator circuit on main chassis defective.</p> <p><i>c.</i> 500-kHz standard signal circuit of radio frequency oscillator A6 defective.</p> <p><i>d.</i> 500-kHz standard signal circuit in main chassis defective.</p> <p><i>e.</i> 1-MHz pulse generator circuit in oscillator control A7 defective.</p> <p><i>f.</i> 5- to 14-MHz amplifier circuit in signal data translator A3 is defective.</p>	<p><i>a.</i> Measure waveform at A7J3; normal is 3.5 volts pep at a 0.3-microsecond rate. Measure waveform at test jack A3J5; normal reading 8.0 volts p-p at a 0.3-microsecond rate. Repair hf oscillator circuit (para 3-13c) or replace CV-1377A /PRC-47.</p> <p><i>b.</i> Check continuity from J10-A2 to J5 A2; repair defective circuit.</p> <p><i>c.</i> Check waveform at test jack A6J4. Normal reading is 4.25 volts pep: measure waveform at test jack A6J3. Normal reading is 3.5 volts pep; repair oscillator circuit (para 3-13e) or replace 0-1032/PRC-47 if defective.</p> <p><i>d.</i> Check continuity from J9-A2 to K4-8, from K4-8 to K4-2 and K4-7, and from K4-2 to J4-1. Repair circuit as necessary or replace K4 if defective. Also check continuity from J9-A3 to J10-A3 and repair if open.</p> <p><i>e.</i> Measure waveform at J11-A1 (main chassis). Normal reading 5.5 volts pep. pulses at 1.0-microsecond rate. Repair 1-MHz pulse circuit (para 3-13f) or replace C-4311/PRC-47.</p> <p><i>f.</i> Measure waveform at J11-A2 is (main chassis). Normal reading 3.0 volts p-p at 0.5-microsecond rate. Check continuity from J11-A2 to J8-A2 and from J11-A1 to J8-A1. Repair circuit (para 3-13c) or replace CV-1377A/PRC-47.</p>

Item	Indication	Probable trouble	Procedure
2	<p>KILOCYCLES indicator does not track with signal generator. Note: Signal generator should be 1-kHz higher than KILOCYCLES indicator reading to produce a 1000 Hz audio tone at the receiver output.</p>	<p><i>g.</i> 100 kHz oscillator signal circuit of radio frequency oscillator A6 defective.</p> <p><i>h.</i> 1.8 to 0.9 MHz pulse circuit of oscillator control A7 is defective.</p> <p><i>i.</i> Dc error signals from discriminator circuit of oscillator control A7 defective.</p> <p><i>j.</i> Dc error signal circuit or anti-lock relay K6 defective.</p> <p>Frequency generation circuits not properly aligned.</p>	<p><i>g.</i> Check waveform at A6J1. Normal reading is 4.5 volts pep at a J0 microsecond rate. Repair 100-kHz circuit (para 3-13e) or replace 0 1032/PRC-47.</p> <p><i>h.</i> Check waveform at base of follower Q24 /normal reading 0.6 volts pip at 0.5-microsecond rate.) Check continuity from J9-A1 to J10-A1: repair circuit (para 3-13f) or replace C-4311JPRC 47.</p> <p><i>i.</i> If voltages not near zero after synchronizing, repair discriminator circuit or replace C-4311 /PRC-47.</p> <p><i>j.</i> Check continuity from J6-3 to J11-5 and K6-4: also from J6-2 tp J11-4 and K6-8: verify that relay K6 operates when a ground is applied to J11-3. Repair circuit or replace relay K6 if defective.</p> <p>Check the drive mechanism and align frequency generation circuits.</p>

d. Receiver Circuit Tests. Perform the folio wine malfunctions to a module within the receiver circuits. procedures in the order listed for isolation of

Item	Indication	Probable trouble	Procedure
<p>Place POWER-LIGHTS switch on the front of RT-671/PRC-47 to POWER OFF. If the procedures of step c have not been performed immediately prior to these tests, connect the test equipment for receiver tests (fig. 3-2.) Adjust the KILOCYCLES indicator for a reading of 2225. Adjust the signal generator to 2226 kHz and set its output level to 2.0 microvolts. On RT-671/PRC-47, set VOLUME control to its maximum clockwise stop, then place POWER-LIGHTS switch to POWER ON.</p>			
1	No signal at grid of 1 st rf amplifier A3V1.	<p><i>a.</i> T/r relay K101 or circuit to antenna terminal defective.</p> <p><i>b.</i> Receiver antenna relay K5 or circuit on main chassis defective.</p>	<p><i>a.</i> Check continuity from AN-TENNA terminal to K101 (COM). Repair circuit if open. Check continuity from K101 (NC) to K101 (COM). Replace K101 if circuit is open.</p> <p><i>b.</i> Check continuity from K101 (NC) to K5 (NC): repair if circuit is open. Check continuity from K5 (NC) to K5 (COM): replace K5 if contacts are open. Check continuity from K5 (COM) to J5-A1: repair if defective.</p>
2	No receive input at A2J3 on amplifier-modulator A2.	<p><i>a.</i> Receive circuit of signal data translator A3 defective.</p> <p><i>b.</i> Receive if. circuit on main chassis defective.</p> <p><i>c.</i> Receive if. circuit at amplifier-modulator input defective.</p>	<p><i>a.</i> Repair CV-1377A/PRC-47 (para 3-13c) or replace module.</p> <p><i>b.</i> Check continuity from J6-A2 to J4-A2: repair if defective.</p> <p><i>c.</i> Repair AM-3507/PRC-47 (para 3-13b) or replace module.</p>
3	No receive audio at test point A1J13 on audio frequency amplifier A1.	<p><i>a.</i> If. amplifier circuits, product detector, or af low-pass filter defective.</p> <p><i>b.</i> Receive audio circuit on main chassis defective.</p>	<p><i>a.</i> Repair AM-3506/PRC-47 (para 3-13a) or replace module.</p> <p><i>b.</i> Check continuity from J4-7 to J2-23: repair if defective.</p>

Item	Indication	Probable trouble	Procedure
4	No audio output (or low output) at headset terminals.	<ul style="list-style-type: none"> a. Driver A1Q10 not adjusted properly or defective. b. Audio output amplifier A1Q11-A1Q12 defective. c. Audio output circuit on main chassis defective. 	<ul style="list-style-type: none"> a. Check audio output at A1J14 (normal 11 volts p-p); adjust receiver gain control (para 3-22), repair AM-3506/PRC-47, or replace module. b. Repair AM-3506/PRC-47 (para 3-13a) or replace module. c. Check continuity from J2-24 to VOLUME control; from VOLUME control to P2-L and P3-L. Repair circuit if necessary. Check VOLUME control for continuity throughout its rotation, check C20 and C24 for shorts, and resistance of R24 and R25 (normal 15K ohms). Replace any defective component, repair the circuit as necessary.
5	Excessive distortion on receive (due to front-end or if overloading).	<ul style="list-style-type: none"> a. The -agc circuit of audio frequency amplifier A2 defective. b. The -agc circuit on the main chassis is defective. c. The +agc circuit of audio frequency amplifier A2 defective. d. The +agc circuit on the main chassis is defective. e. The -agc circuit in signal data translator A3, or the +agc circuit in audio frequency amplifier A2 defective. 	<ul style="list-style-type: none"> a. Check -agc level at A1J15 (normal 0 to -0.5 volts dc); adjust agc gain (para 3-23) Repair AM-3506/PRC47 (para 3-13a) or replace module. b. Check continuity from J2-20 to L2-1, from L2-2 to J6-4; repair as required. Measure resistance of L2 (normal 1.2 ohms); replace if defective. c. Check +agc level at A1J16 (normal +5 to +6 volts dc); repair AM-3506/PRC-47 (para 3-13a) or replace module. d. Check continuity from J2-16 to J4-5; repair as necessary. e. Repair CV-1377A/PRC-47 (para 3-13c) or AM-3506/PRC-47 (para 3-13a), or replace the defective module.

e. *Transmitter Circuit Tests.* Perform the following malfunctions to a module within the transmitter circuits. procedures in the order listed for isolation of

Item	Indication	Probable trouble	Procedure
1	No transmit audio, or low audio level, at balanced modulator input (J3-3).	<ul style="list-style-type: none"> a. Audio frequency amplifier A1 not adjusted properly or defective. b. Transmit audio circuit in main chassis defective. 	<p>Place the POWER-LIGHTS switch on the front panel of RT-671/PRC-47 to POWER OFF. Connect the test equipment for transmitter tests (fig 3-3). Adjust the KILOCYCLES indicator to read 2000. Verify that the selector switch on the antenna simulator is at the 2.0 MHz position. Resonate the power amplifier at the operating frequency using the OPR-TUNE switch</p> <p>Caution: Do not leave the OPR-TUNE switch in the TUNE position for more than a few seconds at a time. Damage to the power amplifier plate circuit can result.</p> <p>Connect the audio oscillator to A1J1 (fig. 3 4) and adjust its output level to 0.1 volt rms at 1.000 Hz.</p> <ul style="list-style-type: none"> a. Check audio at A1J7 (normal 0.25 volts rms); adjust microphone amplifier gain control A1R27 (para 3 25), repair AM-3506/PRC-47 (para 3-13a) or replace defective module. b. Check continuity from J3-3 to J2-22. from J2-C to J3-C and J2-25. Check microphone circuit from P2-E to P3-E and J2 2. Repair as required. Check capacitors C22 and C23 for shorts: replace defective components.

Item	Indication	Probable trouble	Procedure
2	No signal at transmit if. input A2J3.	Balanced modulator circuit of amplifier-modulator A2 defective.	Repair AM-3507/PRC-47 (para 3-13b) or replace defective module.
3	No 500-kHz standard oscillator signal at A2J2 of amplifier-modulator A2.	<ul style="list-style-type: none"> a. 500-kHz standard oscillator circuit on main chassis defective. b. 500-kHz relay K4 defective. c. 500-kHz standard oscillator circuit in amplifier-modulator A2 defective. 	<ul style="list-style-type: none"> a. Check continuity from K4-3 to K4-6 and J3-A2; repair as required. Refer to frequency generation tests (para 3-5c). b. Check for signal at K4-3 and K4-6 when relay operated. Replace K4 if contacts remain open when 26.5-volt vox signal is applied to K4-1. c. Check continuity from J3-A2 to A2J2: repair AM-3507/PRC-47 (para 3-13b) or replace defective module.
4	No transmit signal at if. output (A2J1) of amplifier-modulator A2.	If. amplifier stages in amplifier-modulator A2 defective.	Repair AM-3507/PRC-47 (para 3-13b) or replace defective module.
5	No transmit rf signal at 1 st rf amplifier grid (A3J1) of signal data translator A3.	<ul style="list-style-type: none"> a. Transmit relay A2K1 in amplifier-modulator defective. b. If. circuit on main chassis defective. c. Transmit mixer circuit or amplifier A3Q15 in signal data translator defective. 	<ul style="list-style-type: none"> a. Check signal at J4-A3 (main chassis) when A2K1 operated. Check capacitor C2 on main chassis for shorts; repair circuit on main chassis, repair AM-3507/PRC-47 (para 3-13b), or replace defective module. b. Check continuity from J4-A3 to J6-A1; repair if necessary. c. Repair CV-1377A/PRC-47 (para 3-13c), or replace defective module.
6	No transmit rf signal at grid of power amplifier (J104).	<ul style="list-style-type: none"> a. Rf drive circuit on main chassis defective. b. A1c circuit at power amplifier grid defective. c. A1c circuit on main chassis defective. d. A1c circuits in PA filter box FL2 defective. e. A1c circuit in amplifier-modulator A2 defective. 	<ul style="list-style-type: none"> a. Check continuity from J7-A1 to PA socket XV101-4; repair circuit as necessary. b. Check resistance and continuity of L102 (normal 29 ohms), R104 (normal 47K ohms), R119 (normal 27K ohms). and check capacitors C101A and C141 for shorts. Repair circuit or replace defective components. c. Check continuity from L102-2 to FL2-19, from FL2-6 to J3-2, from C101A to FL2-18, and from FL2-5 to J3-1; repair circuits as necessary. d. Check continuity from FL2-5 to FL2-18, and from FL2-6 to FL2-19: check each terminal for short to chassis ground. Repair circuit or replace C210, C211, C223, C224, C231, C232, L208, or L209 as required. e. Repair AM-3507/PRC-47 (para 3-13b) or replace defective module.
7	XMTR OUTPUT meter M101 indicates little or no output power.	<ul style="list-style-type: none"> a. Power amplifier output circuit defective. b. Rf detector circuit defective. 	<ul style="list-style-type: none"> a. Check continuity of L110, L111, and L112 and from L112 to K101 (NO): repair circuit or replace defective component. b. Check continuity of T101, R129 (normal 470 ohms), and M ADJ pot R117 (normal 5K ohms). Verify that CR102, CR103, C106A/C106B and not shorted. Repair defective circuit or replace component.

Item	Indication	Probable trouble	Procedure
Note.			
Place XMTR PWR switch (S103) to OFF before proceeding with the remainder of these tests.			
8	No sidetone, or low sidetone level, on transmit.	<ul style="list-style-type: none"> c. XMTR PWR switch circuit defective. a. Sidetone detector circuit in power amplifier compartment defective. b. Sidetone circuit in PA filter box FL2 defective. c. Sidetone circuit in main chassis defective. d. Sidetone circuit in audio frequency amplifier A1 defective. 	<ul style="list-style-type: none"> c. Check continuity from CR103 cathode to S103B-7, from S103B-7 to S103B-8, from S103B-8 to FL2-26. from FL2-13 to BATTERY TEST switch S3A (NC) and check value of R118 (normal 1K ohms). Check continuity from FL2-26 to FL2-13 and check each terminal for shorts to ground. Repair circuit or replace defective component. a. Check continuity from J103 to FL2-17, check resistance of R116 (normal 2.2K ohms), R108 (normal 100 ohms), and check CR101, C124, C125, C126, and C140 for shorts. Repair circuit or replace defective component. b. Check continuity from FL2-17 to FL2-4 and check each terminal for shorts to ground. Replace L210, C212, C225, or C236 if defective. c. Check continuity from FL2-4 to J2-17. Repair as necessary. d. Repair AM-3506/PRC-47 (para 3-13a) or replace defective module.
Warning:			
Place the POWER-LIGHTS switch to POWER OFF, disconnect the primary power source cable from the front of RT-671/PRC-47, and discharge the plate circuit capacitors and high-voltage filter capacitors in the power supply before proceeding with the following test. Personal injury or death can result from these dangerous voltages.			
9	Excessive non-linearity in power amplifier stage.	<ul style="list-style-type: none"> a. Feedback circuit in power amplifier compartment defective. b. Feedback circuit in signal data translator A3 defective. c. Power amplifier grid bias adjusted incorrectly. 	<ul style="list-style-type: none"> a. Check continuity from C144 to J7-A2; check capacitors C105 and C144 for shorts; repair circuit or replace defective component. b. Repair CV-1377A/PRC-47 (para 3-13c) or replace defective module. c. Perform adjustment routine of paragraph 327.

f. Relay and Mode Control Tests. Perform the following procedures in the order for isolation of malfunctions to components on the main chassis of the receiver-transmitter.

Item	Indication	Probable trouble	Procedure
Connect power to the receiver-transmitter, attach the antenna simulator and the dummy load as for transmitter tests (fig. 3-3) and place the front panel controls as follows: CW-FSK/VOICE switch to VOICE; OPR-TUNE switch to OPR; KILOCYCLES indicator to 2225; XMTR PWR switch to LO.			
1	Equipment does not switch to transmit mode when ptt switch on handset is pressed.	<ul style="list-style-type: none"> a. Hand set ptt switch defective. b. Handset ptt circuit on main chassis defective. 	<ul style="list-style-type: none"> a. Replace handset and tighten audio input connector. b. Check continuity from J1-11 to J2-11, to P2-F, to P3-F, to FL2-12; also from FL2-25 to S102 (COM 1) and from S102 (NO 1) to S102 (NO 2) and to FL2-16. Check continuity from FL2-3 to P2-H, to P3-H, to S3B (COM), to S2 (COM) and from S2 (NO) to P3-F. Repair defective circuit.

Item	Indication	Probable trouble	Procedure
		<p>c. PA filter box circuit defective.</p> <p>d. PA overtemperature cutout and/or override circuit defective.</p> <p>e. Push-to-talk relay A5K1 in power supply A5 defective.</p> <p>f. Vox relay A1K1 in audio frequency amplifier A1 defective.</p> <p>g. Vox circuit in audio frequency amplifier A1 defective.</p> <p>h. Vox circuit or, main chassis defective.</p> <p>i. Defective ground circuit or operating coil in a relay.</p> <p>j. Transmit relay A21C1 in amplifier-modulator A2 defective.</p>	<p>c. Check continuity from FL2-12 to FL2-25 and from FL2-16 to FL2-3: check each terminal for shorts to ground. Repair circuit or replace C28, C202, C213, C215, C226, C227, C237, L202, or L211 (para 3-9).</p> <p>d. Check continuity across R103. If open, permit unit to cool thoroughly 115 to 20 minutes, and retest. Replace K103 if circuit remains open (para 3-9). Check continuity from S3B (COM) to S3B (NO) with BATTERY TEST switch pressed. Replace if circuit remains open. Check continuity from S2 (COM) to S2 (NO) with CW-FSK/VOICE switch to CW-FSK. Replace S2 if circuit remains open (para 3-91).</p> <p>e. Check continuity from J1-11 to J1-22 Normal 300 ohms), replace A5K1 if winding open (para 3-13d).</p> <p>f. Check continuity from A1K1-3 to A1K1-5 (fig. 3-68): repair AM-3506/PRC-47 (para 3-13a) or replace defective module.</p> <p>f. Check continuity from J2-11 to A1K1-3 and from J2-5 to A1K1-5: measure dc volts from J2-7 to ground with ptt switch pressed. Repair AM-3506/PRC-47 (para 3-13a) or replace defective module.</p> <p>h. Check continuity from J1-20 to J2-7, to J4-4, to K3-1, to K4-1, to K5-1, to FL2-8. Also from FL2-21 to R120-1, to t/r relay K101 coil. Repair defective circuit.</p> <p>i. Measure resistance to ground as follows: K3-1 (normal 1628 ohms); K4-1 (normal 1628 ohms); K5-1 (normal 725 ohms); K101 (C) (normal 270 ohms); K102-1 (normal 684 ohm -); check C145 for short to ground. Measure resistance of R120 (normal 470 ohms) and verify that the following pins are grounded: J1-6, J1-7, J1-12, J2-1, J2-2, J2-3, J3-4, J4-2, J6-1, J7-5, J8-2, J9-3, J11-2. Repair defective circuit or replace faulty component.</p> <p>j. Check winding of relay from J4- to J4-2 (normal 1K ohms); repair AM-3507/PRC-47 (para 3-13b) or replace defective module. Check C2 (on main chassis) for short to ground. Verify that R45 (normal 680 ohms) is not open; replace defective component.</p>

Item	Indication	Probable trouble	Procedure
2	Transmitter does not key when CW-FSK/VOICE switch is at CW.FSK and telegraph key is operated.	<ul style="list-style-type: none"> a. Telegraph key or connecting cord is defective. b. Key circuit on main chassis defective. c. Key circuit in FL2 defective. d. Key circuit in audio frequency amplifier A1 defective. 	<ul style="list-style-type: none"> a. Repair or replace J-45 telegraph key and/or connecting cord. b. Check continuity from P2-K to P3-K, to J2-18, to FL2-10. Check capacitors C21 and C25 for shorts to ground. Repair defective circuit or replace shorted capacitors. c. Check continuity from FL2-10 to FL2-23 and from each terminal to ground. Repair circuit or replace C204, C217, or L204 (para 3-9). d. Check oscillator output at A1J9. Check continuity from J2-18 to A1L2-3. Repair AM-3506/PRC-47 (para 3-13a) or replace defective module.
3	Transmitter does not key when OPR-TUNE switch is in TUNE position.	<ul style="list-style-type: none"> a. OPR-TUNE switch S102 defective. b. Overtemperature cutout has operated or is defective. 	<ul style="list-style-type: none"> a. Check continuity from S102 (NO 2) to S102 (COM 2) with switch at TUNE. Replace S102 if circuit remains open (para 3-9). b. Check continuity from S102 (NO 2) to ground. If open, K103 has operated. Permit K103 to cool for 15 to 20 minutes and then recheck. If circuit is still open; replace K103 (para 3-9).
4	Oscillator control A7 loses control of hf oscillator.	<ul style="list-style-type: none"> a. Automatic oscillator capture circuit defective. b. Antilock relay circuit in main chassis defective. 	<ul style="list-style-type: none"> a. Repair C-4311/PRC-47 (para 3-13f) or replace defective module. b. Place ground at J11-3 and observe that +1.0 volts dc appears at J11-4 and J11-5. If not, check J 11-1 for + 20 volts dc: repair circuit as required. Check continuity from J 11-4 to K6-8 and from J11-5 to K6-4. Repair if open. Check resistance of R126 (normal 19.1K ohms) and R127 (normal 1,210 ohms). Replace K6 if contacts remain open or repair resistor divider.

Section III. ISOLATING TROUBLE

3-6. Trouble isolation Within a Module

a. When the cause of trouble has been localized to a stage or specific circuit within a module or subassembly through use of the troubleshooting charts, the following procedures will isolate the malfunction to a defective component.

WARNING

Avoid contact with the high-voltage circuits of Signal Data Translator CV-1377A/PRC-47 (A3), Power Supply PP-3518/PRC-47 (A5), and in the power amplifier compartment. These voltages can cause personal injury or death.

b. Make all voltage measurements at the tube

sockets and transistor terminals of a questionable circuit or stage. Use the flexible extender cables provided as part of Cable Assembly AN/PRA-4 (fig. 3-84) to extend the suspected module from the main chassis to gain access to the internal adjustments and test points. Refer to the voltage and resistance diagrams for the suspected module or subassembly shown in figures 3-68 through 383. Module disassembly and reassembly procedures are detailed in section V.

CAUTION

When making voltage readings on partially disassembled modules, do not permit the individual card assemblies to

come in contact with one another or with the module chassis.

Component damage can result.

c. If abnormal voltage readings are obtained, remove all power from the module being tested and conduct dc resistance measurements throughout the suspected circuit or stage to isolate any open- or short-circuit conditions, or defective parts. Refer to the module schematic diagrams, (fig. 7-8 through 7-14), or to the transformer and coil resistance data shown in paragraph 3-7.

d. Trouble that does not completely disable the equipments, but which results in decreased receiver sensitivity or transmitter power output can be difficult to isolate and may become time-consuming. When such symptoms are evident, and all circuit checks fail to indicate a defective part, check the alignment of the receiver-transmitter (chapter 4) or consult the adjustment routines of section VI.

3-7. Dc Resistance of Coils and Transformer Windings

a. The dc resistance of coil and transformer windings is shown in the following charts.

(1) *Audio Frequency Amplifier AM-3606/PPC-47 (A8A1) (fig. 7-9).*

Ref des	Terminal no.	Resistance (ohms)
A1K1	1 to 2	800 ± 20%
A1L1	1 to 2	180 ± 10%
A1L2	1 to 2	30 ± 10%
A1L2	2 to 3	420 ± 10%
A1L3	1 to 2	420 ± 10%
A1T1	Yellow to green	190 ± 25%
A1T1	Red to blue (R12 connected)	780 ± 25%
A1T2	1 to 2	150 ± 10%
A1T2	3 to 4	15 ± 10%
A1T3	1 to 2	325 ± 10%
A1T3	3 to 4	100 ± 10%
A1T3	4 to 5	100 ± 10%
A1T5	1 to 2	80 ± 10%
A1T5	2 to 3	80 ± 10%
A1T5	4 to 5	100 ± 10%

(2) *Amplifier-Modulator AM-3507/PRC-47 (A8A2)) (fig. 7-10).*

Ref des	Terminal no.	Resistance (ohms)
A2L1	1 to 2	50 ± 10%
A2L2	1 to 2	16.5 ± 10%
A2L3	1 to 2	50 ± 10%
A2L4	1 to 2	4 ± 10%
A2L5	1 to 2	29 ± 10%
A2L6	1 to 2	3 ± 10%
A2L7	1 to 2	3.5 ± 10%
A2L8	1 to 2	29 ± 10%
A2L9	1 to 2	72 ± 10 %
A2L10	1 to 2	50 ± 10 %
A2T2	1 to 3	1 ± 10 %
A2T2	4 to 6	0.5 ± 10 %
A2T3	1 to 3	5 ± 10 %
A2T3	4 to 6	1 5 ± 10 %

(3) *Signal Data Translator CV-1377A/PRC-47/A8A3) (fig. 7-11).*

Ref des	Terminal no.	Resistance (ohms)
A3K1	3 to 4	1,000 ± 10%
A3L1	1 to 2	Less than 1 ohm
to A3L81		
A3L98A	1 to 2	Less than 0.02 ohms
A3L98B	3 to 4	Less than 0.02 ohms
A3L100	1 to 2	11.1 ± 10%
A3L101	1 to 2	7.5 ± 10%
A3L102	1 to 2	2 ± 10%
A3L103	1 to 2	Less than 0.02 ohms
A3L120	1 to 2	11.6 ± 10%
A3L121	1 to 2	10 ± 10%
A3L125	1 to 2	Less than 1 ohm
to A3L134		
A3L135	1 to 2	1.65 ± 10%
A3L136	1 to 2	Less than 1 ohm
to A3L145		
A3T1	A to B	Less than 0.1 ohm

(4) *Power Supply PP-3518/PRC-47 (A8A5) (fig. 7-12).*

Ref des	Terminal no.	Resistance(ohms)
A5K1	1 to 2	300 ± 10%
A5L1	1 to 2	3 ± 10%
A5T1	1 to 2	.2 ± 10%
A5T1	2 to 3	.2 ± 10%
A5T1	3 to 4	.2 ± 10%
A5T1	4 to 5	.3 ± 10%
A5T1	6 to 7	13 ± 10%
A5T1	8 to 9	18.2 ± 10%
A5T1	10 to 11	65 ± 10%
A5T1	12 to 13	.3 ± 10%
A5T1	13 to 14	.2 ± 10%
A5T1	15 to 16	55 ± 10%
A5T2	1 to 2	12.2 ± 10%
A5T2	3 to 4	.7 ± 10%

(5) *Radio Frequency Oscillator 0-1032/PRC-47 (A8A6) (fig. 7-13).*

Ref des	Terminal no	Resistance (ohms)
A6L1	1 to 2	2.6 ± 10%
A6L2	1 to 2	11.6 ± 10%
A6L3	1 to 2	7.5 ± 10%
A6L4	1 to 2	16.5 ± 10%
A6L5	1 to 2	3.9 ± 10%
A6L6	1 to 2	72 ± 10%
A6L7	1 to 2	29 ± 10%
A6L8	1 to 2	21 ± 10%
A6L9	1 to 2	72 ± 10%

(6) *Oscillator Control C-4311/PRC-47 (A8A7) (Fig. 7-14)*

Ref des	Terminal no	Resistance (ohms)
A7L1	1 to 2	4.5 ± 10%
A7L2	1 to 2	2.6 ± 10%
A7L3	1 to 2	50 ± 10%
A7L4	1 to 2	11.6 ± 10%

Ref des	Terminal no.	Resistance ohms
A7L5	1 to 2	50 ± 10%
A7L6	1 to 2	50 ± 10 %
A7L7	1 to 2	11.6 ± 10 %
A7L8	1 to 2	50 ± 10%
A7L16	1 to 2	7.5 ± 10%
A7L17	1 to 2	7.5 ± 10%
A7L18	1 to 2	7.5 ± 10%
A7L19	1 to 2	1.8 ± 10%
A7L21	1 to 2	16.5 ± 10
A7L22	1 to 2	16.5 ± 10
A7L23	1 to 2	7.5 ± 10%
A7L24	1 to 2	7.5 ± 10%
to A7L26		
A7L28	1 to 2	7.5 ± 10%
to A7L32		
A7L34	1 to 2	29 ± 10%
to A7L37		
A7T1	primary	1.6 ± 10%
A7T1	half secondary	1.6 ± 10%
A7T1	half secondary	1.6 ± 10%
A7T2	primary	3.25 ± 10
A7T2	half secondary	1.25 ± 10
A7T2	half secondary	1.25 ± 10
A7T3	primary	1.6 ± 10%
A7T3	half secondary	1.6 ± 10%
A7T3	half secondary	1.6 ± 10%
A7T4	primary	3.25 ± 10
A7T4	half secondary	1.25 ± 10

(7) Electrical Equipment Chassis CH-474/PRC-47 (A8A4) (fig. 7-8).

Ref des	Terminal No.	Resistance (ohms)
L1	1 to 2	1.2 ± 10%
L2	1 to 2	1.2 ± 10%
L3	1 to 2	1.2 ± 10%
L4	1 to 2	Less than 1 ohm.
L5	1 to 2	72 ± 10%
L6	1 to 2	72 ± 10%
T1	1 to 2	1 ± 20%
T1	2 to 3	60 ± 20%
T1	3 to 4	1 ± 20%
T2	1 to 2	80 ± 20%
T2	3 to 4	2.2 ± 10%
T3	1 to 2	.2 ± 10%
T3	3 to 4	.5 ± 10%

(8) Power Amplifier Compartment (A8A1) (fig. 7-8).

Ref des	Terminal no	Resistance ohms
L102	1 to 2	29 ± 10%
L103	1 to 2	50 ± 10%
L104	1 to 2	Less than 1 ohm
L105	1 to 2	3.2 ± 10%
L106	1 to 2	2.1 ± 10%
L109	1 to 2	Less than 1 ohm.
to L112		
L120	1 to 2	.09 + 10%
L121	1 to 2	.09 + 10%
L122	1 to 2	11.6 + 10%
L123	1 to 2	11.6 + 10%

(9) Power Amplifier Filter Box FL2 (A8A4A1) (fig. 7-8)

Ref des	Terminal no	Resistance ohms
L201	FL2-13 to FL2-26	29 ± 10%
L202	FL2-12 to FL2-25	29 ± 10%
L203	FL2-11 to FL2-24	29 ± 10%
L204	FL2-10 to FL2-23	29 ± 10%
L205	FL2-9 to FL2-22	29 ± 10%
L206	FL2-8 to FL2-21	2 ± 10%
L207	FL2-7 to FL2-20	29 ± 10%
L208	FL2-6 to FL2-19	29 ± 10%
L209	FL2-5 to FL2-18	29 ± 10%
L210	FL2-4 to FL2-17	29 ± 10%
L211	FL2-3 to FL2-16	29 ± 10%

b. Generally the forward resistance of the semiconductor diode is less than 100 ohms, while the reverse resistance will be greater than 10,000 ohms. Resistance measurements are not always a true indication of diode and transistor circuit performance, and serious damage can result by making these measurements with an ordinary ohmmeter.

CAUTION

Do not make diode resistance measurements with multimeter TS-352A/U or with any other instrument whose source voltage exceeds 1.5 volts dc. The semiconductor can be irreparably damaged by such voltages.



Figure 3-84. Cable Assembly Set AN/PRA-4, Equipment Supplied.

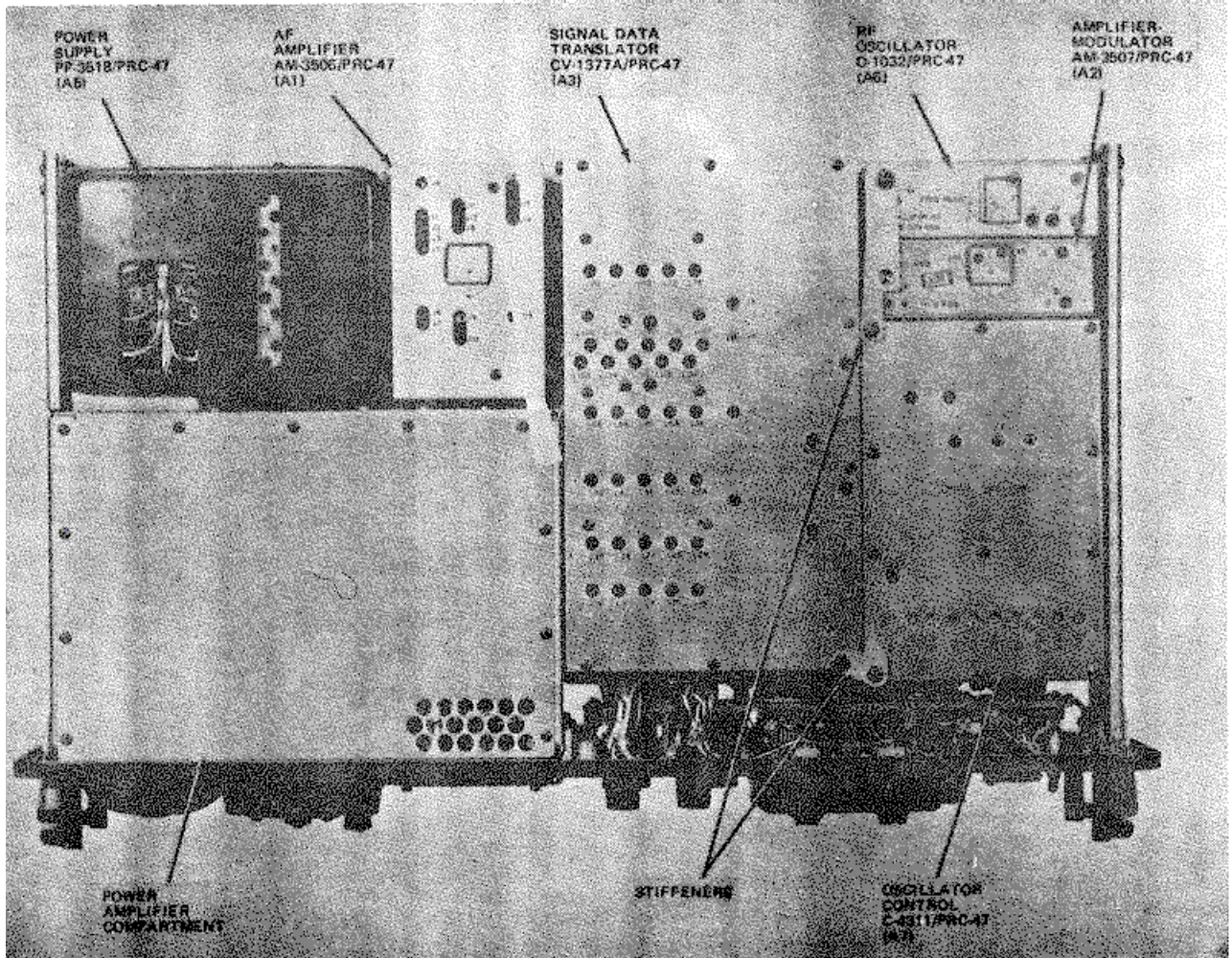

Figure 3-85. Radio Receiver-Transmitter RT-671/PRC-47, (A8) Top View, Location of Modules and Stiffeners.

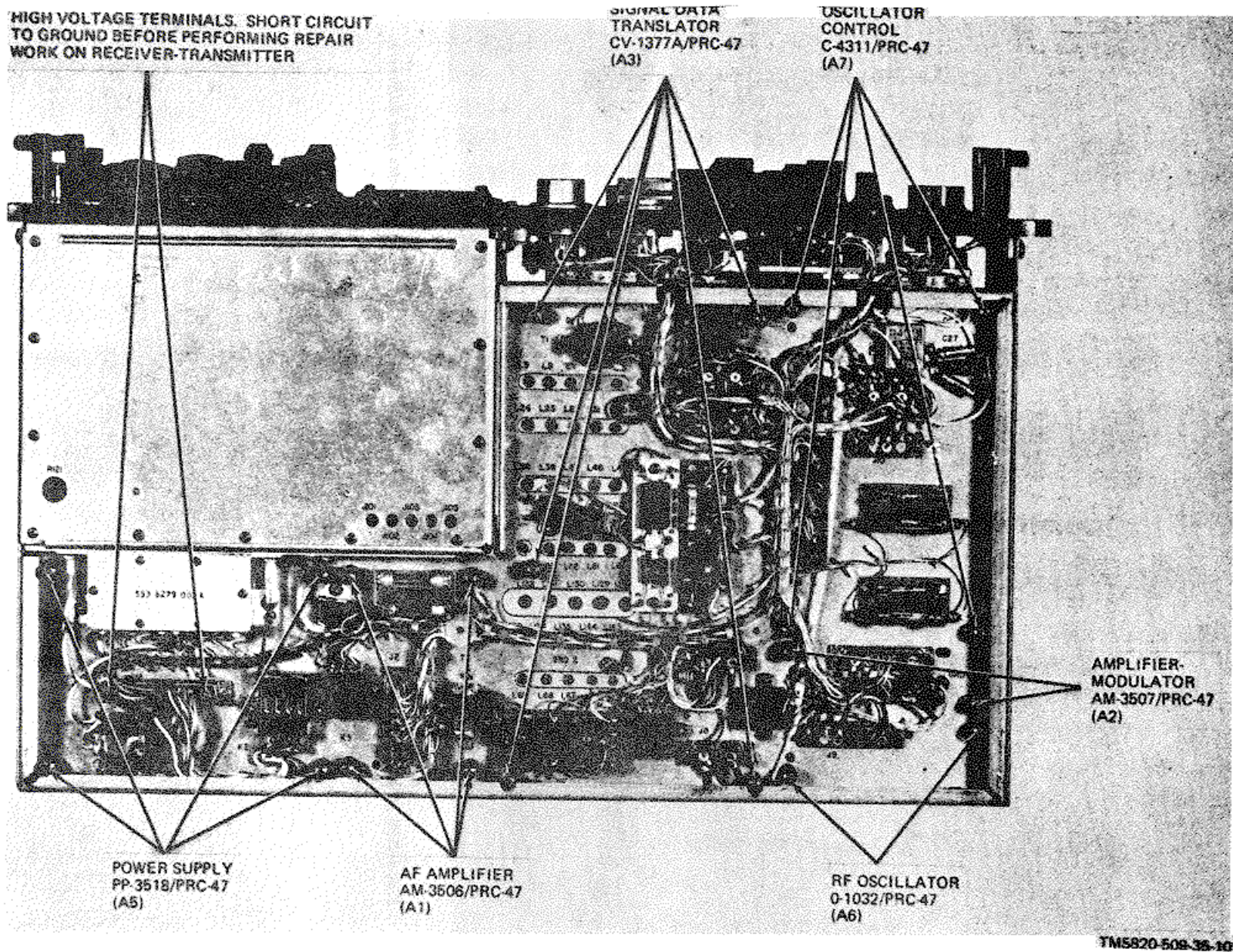

Figure 3-86. Radio Receiver-Transmitter RT0-671/PRC-47 (A8), Bottom View, Location of Module Retaining Screws.

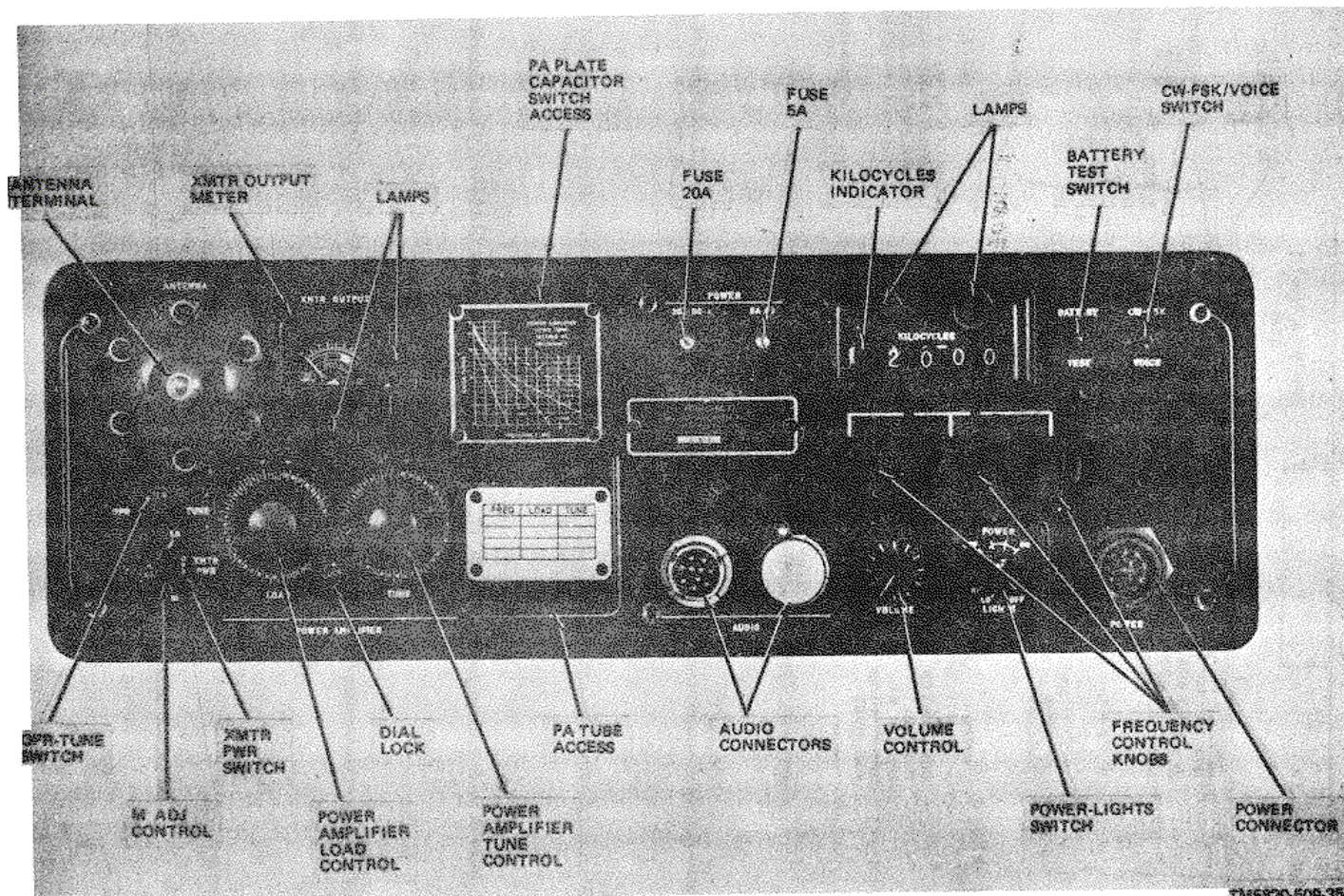

Figure 3-87. Radio Receiver-Transmitter RT-671/PRC-47 (A8), Front Panel View, Location of Access Opening and Panel Components.

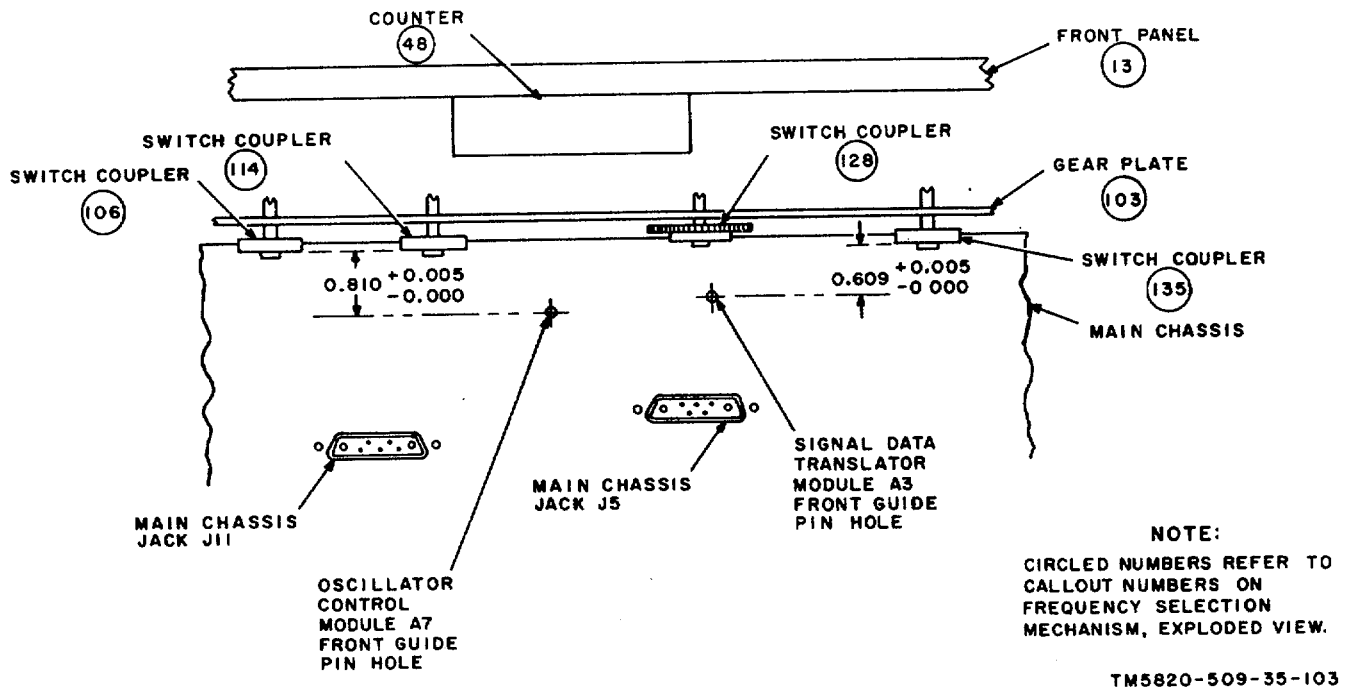

Figure 3-88. Frequency Selector Control, Switch Coupler Alignment Diagram

Figure 3-89. Radio Receiver-Transmitter RT-671/PRC-47, Power Amplifier Compartment (A8A4A)), Load-Tune Coil Assembly, Exploded View.
(Located in back of manual.)

Figure 3-90. Radio Receiver-Transmitter RT-671/PRC-47, Frequency Selection Mechanism (A8A4A1) , Exploded View.
(Located in back of manual.)

Figure 3-91. Radio Receiver-Transmitter RT-671/PRC-47, Power Amplifier Compartment (A8A4A1) , Plate Capacitor Switch, Exploded View.
Located in back of manual.)

Figure 3-92. Radio Receiver-Transmitter RT-671/PRC-47, Power Amplifier Compartment (A8A4A1) , XMTR PWR Switch (S103) , Exploded View.
(Located in back of manual.)

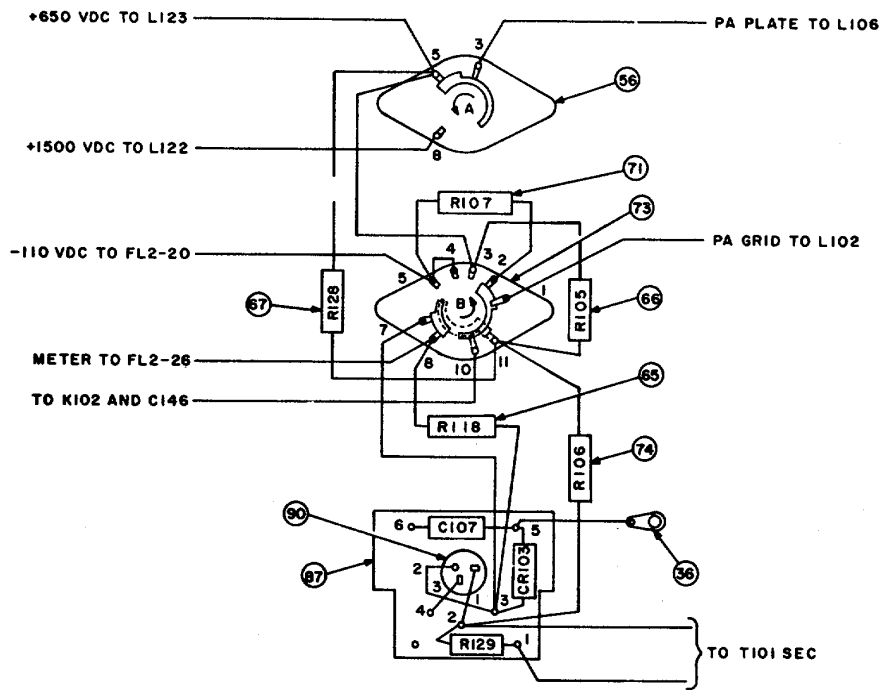

NOTES:

1. SWITCH SHOWN IN XMTR PWR LOW POSITION.
2. SWITCH VIEWED FROM REAR, WITH DRIVE END AT TOP.
3. CIRCLED NUMBERS ARE CALLOUTS ON XMTR PWR SWITCH EXPLODED VIEW.

TM 5820-509-35-108

Figure 3-93. Radio Receiver-Transmitter RT-671/PRC-47, Power Amplifier Compartment, XMTR PWR Switch (S103) (A8A4A1), Connection Diagram.

Section IV. REPAIR

3-8. General Parts Replacement Techniques

a. Most component parts of Radio Set AN/PRC-47 are readily accessible by removing the malfunctioning module, then its card assembly, and finally the defective component. Those mechanical and electrical repairs that require extensive disassembly of the equipment are best performed in well-lighted, uncluttered, and reasonably clean surrounds.

b. The following general precautions apply in performing repair procedures on the AN/PRC-47.

(1) When soldering or unsoldering precision resistors, transistors, or other semiconductor devices, solder quickly to reduce the heat conduction to as low as amount as possible. When space limitations permit, use a heat sink between the solder joint and the component being soldered.

(2) A pencil-type, 25-watt soldering iron is recommended for removal and replacement of semiconductor devices (transistors, diodes, zeners, varicaps, etc.). When alternating current is used to heat the soldering iron, an isolation transformer is recommended to reduce the possibility of electrical transients being induced into the circuit, or a polarity difference from existing between the soldering iron and the component being soldered.

CAUTION

Always check the soldering iron for short-circuits to the tip before using it. Do not use a soldering gun because damaging voltages can be induced into the component.

(3) When replacing a component, particularly those in the tuned circuits and frequency

generation sections of the equipment, always adjust the replacement component lead length, component placement, and proximity to adjacent devices as nearly as possible to the original installation. This minimizes the final alignment adjustments for the stage.

(4) High power semiconductor devices are often mounted on heat sinks. Whenever a device is replaced, always replace the insulating washer(s) if they have been used in the original installation.

CAUTION

Before installing insulating washers, treat them with silicone fluid or compound to enhance the heat conductivity through the washer. Check the continuity between the semiconductor case and the heat sink before making other electrical connections to the replacement device.

(5) When replacing ceramic or glass components, use a heat sink and avoid excessive pressure when gripping the component or its leads during soldering and attachment.

(6) Subminiature tubes are wired directly into the subassemblies: apply heat to these electrode leads carefully to avoid damage to the tube envelope

(7) Avoid overheating the capacitor body when replacing ceramic feed-through capacitors in a chassis. The plating can be destroyed by excessive heat.

(8) When tightening the setscrews in a collar-type clamp, the setscrews must be tightened against the center of the mechanical part.

(9) Special care must be exercised when soldering the terminal posts of some variable capacitors. Excessive heat can loosen the stator plates of some assemblies.

3-9. General Removal and Replacement Procedures

a. These general procedures are in addition to the specific routines listed in section V and are intended to act as guidelines to assist the maintenance technician in the removal and replacement of components in assemblies of Radio Receiver-Transmitter RT-671 /PRC-47.

b. Whenever component parts are removed for repairs, adjustments, or internal measurements:

(1) Remove all power from the equipment, and ground the high-voltage circuits at chassis connectors J1-A1 and J1-A2.

(2) Before removing Signal Data Translator CV-1377A/PRC-47 (A8A3) or Oscillator Control C-4311/PRC-47 (A8A7) adjust the front panel frequency control knobs to provide a reading of 2000 on the KILOCYCLES indicator. This places the shaft couplers of these modules in the proper position to facilitate module removal from the main chassis.

(3) When servicing the driver tube (A3V3) and the power amplifier tube (V101), remove the tube and its heat sink as a unit from the subassembly. Carefully observe the orientation of these tubes in their heat sink before separating them; installation of the replacement tube is easier if the heat sink is properly oriented outside the subassembly.

(4) Disassemble only those items and component subassemblies that are required to perform the desired maintenance. Any defective part that cannot be repaired should be replaced.

(5) Soldering must be in accordance with Military Specification MIL-S-6872. Use only rosin-core solder. A wire solder containing 60-percent tin and 40-percent lead, having a diameter of 1/16-inch and meeting the general requirements of this specification is available in one-pound quantities under Federal Stock Number 3439-753-1874.

(6) Clean all parts after soldering to remove residual rosin. Denatured alcohol (FSN 6810-222-2373) is recommended for this purpose.

(7) Replacement wiring should be the same length and gage as the wire it replaces and should be dressed to conform to the routing of the original conductor.

(8) Remove a defective part from a printed circuit card by clipping its leads as close to the terminal hole as possible.

(9) Clear the terminal hole of a printed circuit card by applying only enough heat to cause the solder to flow; then clear the solder and clipped component lead out of the terminal hole with a small pick.

(10) Insert the lead wire(s) of the replacement component into the terminal holes of the printed circuit card and adjust their individual lengths and dress to locate the replacement component in the same position as the original one (use parts location photographs to verify the location of this replacement part). Solder the leads using a heat sink; then clip off the excess lead wire.

c. Printed circuit card repair is not recommended unless the repair is minor. The following procedures are recommended when such repair is desired.

(1) Eliminate the progress of a crack in the circuit card by drilling a stop hole (no. 65 drill) at the end of the crack.

(2) If a Crack extends under or through the

printed circuit, a suitable conventional wire may be soldered to the circuit to bridge the area of a crack. Standoff terminals or eyelets may be added to facilitate connection of component leads provided the circuit is not altered.

(3) If an area of the printed circuit has lifted from the board without cracking, and for a length of not more than one inch, the printed circuit can be fastened back to the board as follows:

(a) Clean the raised area of the circuit with technical acetone, FSN 6810-184-4795 (one gallon).

(b) Prepare a bonding material by mixing equal quantities of epoxy sealing compound (FSN 8030-589-8477, 1/2 pt.) and hardener (FSN 8030543-2587, 1/2 pt.). Mix only enough to do the immediate Job since it cannot be retained for later use.

(c) Press the circuit net and apply the bonding agent so that it extends about 1/16-inch beyond the raised circuit in all directions.

(d) Permit the bonding agent to air dry for at least 24 hours before using the card or doing further work on the circuit.

Section V. ASSEMBLY AND DISASSEMBLY

3-10. General

The tools required for removal of modules are included in Tool Kit, Radar and Radio Repair, TK87/U. Module retaining screws are shown in figure 3-86. Before removing Signal Data Translator CV-1377A/PRC-47 (A3) or Oscillator Control C-4311/PRC-47 (A7), set the KILOCYCLES indicator on the front panel of RT-671/PRC-47 to 2000. This is necessary to align the drive shaft couplings of these modules in a vertical position so that the modules can be easily removed from the chassis without coupling damage.

WARNING

Before removing any equipment cover or module from Radio Receiver-Transmitter RT-671 /PRC-47, disconnect all power from the unit.

3-11. Removal and Replacement of Receiver-Transmitter Case

a. Removal.

(1) Loosen the six screws that secure Panel Cover CW-647/PRC-47 to the RT-671/PRC-47; remove the cover.

(2) Invert the RT-671/PRC-47 so that it rests face down on the handles attached to the front panel.

(3) Loosen and remove the six screws on the bottom of the case that secure the case to Electrical Equipment Chassis CH-474/PRC-47.

(4) Carefully lift the case from the receiver-transmitter.

b. Replacement.

(1) Invert the Radio Receiver-Transmitter RT-671/PRC-47 so that it rests on the handles attached to the front panel.

(2) Clean the interior of the case to remove any accumulated dust or dirt.

(3) Carefully lower the case over the electronic equipment chassis until the six screw holes in the bottom of it are properly aligned to permit insertion of the screws. Install the six screws and tighten securely.

(4) Invert the unit to its normal operating position and install Panel Cover CW-647/PRC-47; tighten the six attaching screws.

3-12. Removal and Replacement of Plug-in Modules

WARNING

High voltages are present in the circuits associated with Signal Data Translator CV-1377A/PRC-47, Power Supply PP-3618/PRC-47, and the power amplifier compartment. These voltages are dangerous and can cause personal injury or death. Ground the two high-voltage terminals on the main chassis (J1-A1 and J1-A2) to discharge the capacitors in the high-voltage circuits before beginning maintenance within the chassis or inside any module.

a. *General.* Before loosening the module retaining screws (fig. 3-86), remove the upper module stiffeners (fig. 3-85). To remove the module from the main chassis, loosen the captive hardware and carefully lift the module from the chassis connector. The following detailed procedures apply to all plug-in modules of Radio Receiver-Transmitter RT-671/PRC-47.

b. Removal.

(1) Invert RT-671/PRC-47 to expose the main chassis components and wiring.

(2) Loosen the four captive screws Five for Signal Data Translator CV-1377A/PRC-47, and two each for Amplifier-Modulator AM-3507/PRC-47 and Radio Frequency Oscillator O-

1032/PRC-47) at the locations shown in figure 386.

(3) Return the receiver-transmitter to its upright position.

(4) If the module being removed is Signal Data Translator CV-1377A/PRC-47 (A3) or Oscillator Control C-4311/PRC-47 (A7), adjust the KILOCYCLES indicator to 2000 before attempting to remove the module from the main chassis.

(5) Carefully pull the module straight out of its mating chassis connector using the handle on top of the module if available.

c. Replacement.

(1) Align the module guide pins with the guide holes in the main chassis.

CAUTION

Before attempting to install Signal Data Translator CV-1377A/PRC-47 at location A8A3 or Oscillator Control C-4311/PRC47 at location A8A7 on the main chassis, set the KILOCYCLES indicator to 2000, then adjust the module shaft coupling to the orientation shown in figure 3-44 (CV-1377A/PRC-47) or figure 3-63 (C-4311/PRC-47) to prevent damage to the module or its drive shaft during replacement.

(2) Press the module firmly into its chassis connector.

(3) Tighten the module retaining screws (fig. 3-86) to secure the module to the chassis.

(4) If no further modules are to be serviced and maintenance procedures are complete, replace the module stiffeners (fig. 3-85) and return the receiver-transmitter to its case using the procedures detailed in paragraph 3-11b.

3-13. Module Assembly and Disassembly Procedures

a. Audio Frequency Amplifier AM-3506/PRC47 (A8A1). (fig. 3-6, 3-16 through 3-19)

(1) Disassembly Procedures.

(a) Loosen and remove the two 4-40 x 5/16 pan head screws and their associated washers that secure the cover to the module chassis; carefully remove the cover by lifting it from the module.

(b) To remove card assembly E3 (containing the driver and agc amplifier stages), loosen and remove the four 2-56 x 1/4 flat head screws (two per side) that secure this card assembly to the sides of the module chassis; carefully fold the card assembly forward out of the chassis.

(c) To remove card assembly E2 (containing the microphone and audio amplifier stages), loosen and remove the six 2-56 x 1/4 flat head screws (three per side) that secure this card assembly to the sides of the modules chassis carefully fold this card forward (away from E1).

(d) To remove card assembly E1 (containing the cw oscillator and vox circuits), first perform step (c) to remove card assembly E2; then loosen and remove the six remaining 2-56 x 1/4 net head screws (three per side) that secure this card assembly to the sides of the module chassis. Carefully fold this card forward to expose the components mounted to the face of it. (R83 is connected to the back of this card, opposite R85).

(e) The component parts attached directly to the module chassis may be individually removed as required for repair or replacement.

NOTE

If interconnecting wires between the card assemblies or between a card and the module connector, or between individual components on the chassis are removed to affect repairs, tag each wire carefully so that it may be reconnected to its proper terminal location.

(2) *Repair Procedures.* Replace any defective component or repair the circuit using the procedures outlined in section IV. Component parts shown on the module schematic diagram (fig. 7-9) are located on figures 3-16 through 3-19.

CAUTION

When using a soldering iron to remove or to replace a component part, use only enough heat to cause the solder to flow. Excess heat can damage the component and may also damage the printed circuit. (3) Reassembly Procedures.

(a) Replace and solder any wires removed from the module connector or between the card assemblies during disassembly and repair procedures.

(b) Install the circuit cards in their respective locations (fig. 3-6) beginning with card assembly E1, if it has been removed.

CAUTION

When installing card assemblies E 1 and E2 in the chassis dress the module cabling to prevent stressing the cards. Card or component damage can result if these card assemblies are forced into place.

(c) Secure the card assemblies in place with the 2-56 x 1/4 flat head screws (eight per side).

(d) Replace the module cover and secure it in place with two 4-40 x 5/16 pan head screws and associated flat washers inserted through the holes in the top of the cover.

NOTE

When replacing the module cover, observe the notch orientation in the bottom edges of the cover; verify that the cover is fully seated before attempting to install the retaining screws and washers.

b. *Amplifier-Modulator AM-3507/PRC-47 (A8A2)*. (fig. 3-7 3-8, 3-20 and 3-21)

(1) *Disassembly Procedures*.

(a) Remove the four 4-40 x 3/16 flat head screws that secure each side cover to the module chassis.

NOTE

If interconnecting wires between card assemblies or between a card and the module connector must be removed to affect repairs tag each wire carefully so that it may be reconnected to its proper terminal location.

(b) To remove card assembly E1 disconnect the two shielded wires (from test point J2 and P3-A2) from the terminal adjacent to capacitors C7 and C8 (fig. 3-7). Next remove the four remaining wires that interconnect P3 (terminals 1 through 4) with terminals on the card. Remove the five wires that interconnect card assembly E1 with card assembly E2 (two wires are adjacent to transformer T2). Finally remove the four 4-40 x 3/16 pan head screws that secure the card assembly to the module chassis.

(c) To remove card assembly E2 disconnect the seven wires (2 near transformer T2) that interconnect this card assembly with the remaining circuits of the module. Loosen and remove the two 4-40 x 3/16 pan head screws that secure the card assembly to the module chassis.

(d) Card assemblies E3 E4 and E5 are accessible from the opposite side of the module chassis. Disassemble and tag the circuit components if they are removed.

(2) *Repair Procedures*. Replace any defective component or repair the circuit using the procedures outlined in section IV. Component parts shown on the module schematic diagram Fig 7-10, are located on figures 3-20 and 3 21.

CAUTION

When using a soldering iron to remove or to replace a component, part use only enough heat to cause: the solder to flow. Excess heat can damage the component and may also damage the printed circuit.

(3) *Reassembly Procedures*.

(a) Replace and solder any wires removed from the module connector or between the card assemblies during disassembly or repair procedures.

(b) Install the card assemblies in their respective locations (fig. 3-7 and 3-8) and secure them in place with the 4-40 x 3/16 pan head screws.

(c) Replace the module side covers and secure them with the 4-40 x 3/16 flat head screws (four per side) to the module chassis.

NOTE

Be sure to place the proper cover on each side of the module so that its silkscreen agrees with the assembly it covers.

c. *Signal Data Translator CV-1377A/PRC-47 (A8A3)*. (fig. 3-9 3-10 3-22 through 3-44)

(1) *Disassembly Procedures*.

(a) Remove the 4-40 x 1/4 screws that secure the top and/or bottom covers to the module chassis.

(b) To remove card assemblies E47 and E48 remove the four 4-40 x 1/4 flat head screws from the right side of the module chassis and lift the card assemblies upward and out of the unit through the top of the chassis.

(c) To remove card assemblies TB 1 and TB2 remove the two 4-40 x 1/4 flat head screws from the right side of the chassis and lift the card assembly out through the bottom of the chassis.

(d) To remove card assembly E46, remove the two 2-56 x 3/16 screws from the divider and lift the card assembly out through the bottom of the chassis.

(e) To remove any switch card assembly first verify that the frequency range switch shaft coupling is in the position shown in figure 3-44; then perform steps (f) through (h).

(f) Remove the C-shaped retaining ring from the rear of the frequency range switch shaft (fig. 3-43).

(g) Withdraw the shaft from the module through the coupler end of the unit.

(h) Slide out the desired switch card(s).

NOTE

If the vfo subassembly with switch cards S6 and S7 is to be removed loosen and remove the two 4-40 x 3/16 screws at the right side of the module before lifting the vfo subassembly out. The assembly consisting of switch cards S1 S2 and S3 (as well as the vfo subassembly) are fastened together and must be removed as a unit. Further disassembly may be required before repair to an individual component or card can be affected. If interconnecting wires or component leads interconnect these individual cards carefully tag each lead before removing it to assure that it can be reconnected to the

proper location on the card during reassembly procedures.

(2) *Repair Procedures.* Replace any defective component or repair the circuit using the procedures outlined in section IV. Component parts shown on the module schematic diagram (fig. 7-12) are located on figures 3-22 through 3-43).

CAUTION

When using a soldering iron to remove or to replace a component part, use only enough heat to cause the solder to flow. Excess heat can damage the component and may also damage the printed circuit.

(a) Vacuum tubes V1 and V2 (part of card assemblies TB1 and TB2 respectively) are connected directly to terminals on the card. To remove these tubes, unsolder each electrode lead carefully from the terminal and then remove the tube from its shield. (Install a new tube and solder each electrode lead to its proper terminal location as shown in figures 3-22 and 3-23).

(b) To replace driver tube V3 (fig. 3-9), remove the four screws that secure the heat sink to the right side of the module chassis. Remove the heat sink and the tube from socket XV3. (Install the new tube in the tube socket and replace the heat sink and its corrugated contactor over the replacement tube before again installing the four retaining screws.

(3) *Reassembly Procedures.*

(a) Replace and solder any wires removed from the module connector or between card assemblies during the disassembly and repair procedures.

CAUTION

Before replacing the switch cards in the module, make sure that each switch rotor is placed in position no. 1 (fig. 3-42). Equipment damage can result if the band switches are not properly oriented before insertion in the module.

(b) Reassemble switch group SI-S2-S3 (fig. 3-24, 3-25) and vfo-S6-S7 (fig. 3-31, 3-32) if they were disassembled.

(c) Install card assemblies TB1, TB2, E46, E47, E48 and the vfo subassembly in their proper locations in the module chassis using the appropriate hardware.

(d) Install the switch cards and switch card groups in their respective slots if they have been removed.

NOTE

The keyway in switch card assemblies S6-S7 and S10 must be oriented toward the bottom of the

module chassis before inserting these cards in their respective slots.

(e) With all switches installed, carefully replace the frequency range switch shaft with the groove in the coupling end of it oriented as shown in figure 3-44.

CAUTION

When inserting the frequency range switch shaft be careful that the rotor position of the switches is not disturbed. Do not use excess force when threading this shaft through the switch rotors; switch parts can be damaged unless extreme care is used.

(f) Replace the C-shaped retaining ring in the groove at the rear end of the frequency range switch shaft.

(g) Replace the top and bottom covers on the module and secure them with the 4-40 screws removed in step c(1)(a).

(h) Before installing the module in the main chassis of the receiver-transmitter, observe the CAUTION in step 3-12c.

d. *Power Supply PP-3518/PRC-47 (A8A5)* (fig. 3-11, 3-45 through 3-51).

(1) *Disassembly Procedures.*

(a) Loosen and remove the two 4-40 x 5/16 pan head screws and the one 4-40 x 5/16 flat head screw that secure the plastic cover of the module to the chassis: remove the cover.

WARNING

Before further disassembly, short-circuit connector pins PI-A1 and P1-A2 to ground to discharge the high-voltage filter capacitors. Personal injury or death can result from these voltages.

(b) To remove subassembly no. 1 (fig. 3-46, 3-47), loosen and remove the four 4-40 x 1/4 pan head screws and carefully fold the subassembly down and out of the way.

(c) To remove subassembly no. 2 (fig. 3-48), loosen and remove the four 4-40 x 3/8 pan head screws and carefully fold the subassembly up out of the way.

(d) To remove subassembly no. 3 (fig. 3-49), loosen and remove the two 4-40 x 5/16 net head screws, their flat washers and stop nuts: carefully lift the subassembly out of the chassis.

(e) To remove voltage regulator subassembly TB1 (fig. 3-51), loosen and remove the 4-40 x 1/16 pan head screw that secures the bracket and the terminal post to the chassis; then loosen the 6-32 x 1/2 pan head screw that secures T2 and the other voltage regulator bracket to the module chassis. There is a flat washer under the.

head of this 6-32 screw, and a nut washer, lock washer, and hex nut above the chassis at the bracket end).

NOTE

If interconnecting wires between subassemblies, or between components and the module connector must be removed to affect repairs, tag each wire carefully so that it may be reconnected to its prop. terminal location.

(c) Major piece parts that are mounted directly to the chassis may be removed by first disconnecting the component lead and then removing the mounting hardware that secures the component to the module chassis.

(2) *Repair Procedures.* Replace any defective component or repair the circuit using the procedures outlined in section IV. Component parts shown on the module schematic (fig. 7-12) are located in figures 3-45 through 3-51.

CAUTION

When using a soldering iron to remove or replace a component part, use only enough heat to cause the solder to flow. Excess heat can damage the component and may also damage the printed circuit card.

(3) *Reassembly Procedures.*

(a) Replace and solder any wires removed from the module connector or between subassemblies during the disassembly or repair procedures.

(b) Install the subassemblies in their respective locations and secure each in place with the appropriate hardware. If voltage regulator subassembly TB1 has been removed, install this assembly before attaching subassemblies no. 1 and no. 2 to the module chassis.

(c) Replace the plastic cover over the module and secure it with the hardware removed earlier.

e. *Radio Frequency Oscillator 0-1032/P:RC-47 (A8A6).* (fig. 3-12, 3-13, 3-52 and 3-53)

(1) *Disassembly Procedures.*

(a) Loosen and remove the two 4-40 x 5/16 pan head screws in the top of the module cover, then pull the cover from the chassis of the module.

(b) To remove the card assemblies (fig. 3-12 and 3-13), loosen and remove the six 2-56 x 3/16 pan head screws that secure them to the module chassis; carefully lift each card assembly out of the module.

NOTE

The 500-kHz circuits are mounted directly to the module chassis. Defective individual components of this circuit may be removed and replaced as required. If interconnecting wires between the module connector and the

subassemblies or between individual assemblies are removed to affect repairs, tag each wire carefully so that it may be reconnected to its proper terminal location.

(2) *Repair Procedures.* Replace any defective component or repair the circuit using the procedures outlined in section IV. Component parts shown on the module schematic diagram (fig. 7-3) are located in figures 3-52 and 3-53.

CAUTION

Do not attempt to repair card assembly E2. This subassembly and the encapsulated crystal circuit must be carefully removed and returned to the depot for repair and adjustment. Failure to do so may result in off-frequency operation or malfunction of the equipment. When using a soldering iron to remove or replace a component part, use only enough heat to cause solder to flow. Excess heat can damage the component and may also damage the printed circuit.

(a) Remove card assembly E2 as follows:

1. Unsolder and tag the wires that connect to card assembly E1 and to resistor R44 on the chassis; disconnect the shielded wire on the back of card assembly E2.

2. Carefully press card assembly E2 out of its location through the side of the module.

NOTE

Press the top of the card over the lip of the chassis toward the rear of the unit, then work the card upward until the bottom of the card can be removed over the rim at the bottom of the module chassis.

(3) *Reassembly Procedures.*

(a) If card assembly E2 has been removed, carefully install the replacement unit in the same location. Refer to figure 3-52 for proper orientation of this card assembly.

NOTE

Before installing card assembly E2, be sure that the sponge rubber covering is installed over the top of the card and encloses the oscillator subassembly and its tank circuit components.

(b) Solder any wires removed from the module connector or between card assemblies during disassembly or repair procedures.

(c) Install the card assemblies in their assigned positions (fig. 3-12).

(d) Secure card assembly E1 to the module chassis with the six 2-56 x 3/16 pan head screws.

(e) Replace the module cover and verify that it is seated properly before securing it in place with the two 4-40 x 5/16 pan head screws and their associated flat washers.

f. *Oscillator Control C-4311/PRC-47 (A8A7)*. (fig. 3-14, 3-15, 3-54 through 3-63)

(1) *Disassembly Procedures.*

(a) Remove the module covers by loosening and removing the 4-40 screws that secure the top and/or bottom covers to the module chassis.

NOTE

Several circuit card assemblies of this module are interconnected with lead wires. Where necessary, unsolder the interconnecting wire and tag it carefully so that it may be correctly reconnected to the appropriate terminal during reassembly procedures.

(b) Remove the 4-40 x 3/16 flat head screw on the right side of the chassis near the bottom that secures the nylon cable clamp to the chassis. Carefully slide card assembly E1 out through the bottom of the module; then slide out card assembly E2 and TB1 in that order.

(c) To remove card assembly E4, first unsolder the wire that connects this card to card assembly E5 (fig. 3-14). Then remove card assembly E4 through the bottom of the module.

(d) To remove card assembly E5, it is first necessary to remove switch card assemblies E6, E7 and E8. With these cards removed (as a unit), card assembly E5 can be readily withdrawn from the module chassis using the procedures detailed in steps (e) through (i).

(e) Verify that the switch couplers are aligned as shown in figure 3-63 with the grooves in the coupling half vertical and the index spots in the positions shown.

NOTE

The coupler associated with switch S2 must be positioned at its maximum counterclockwise stop (10 turns) in addition to having the groove in the coupling half oriented vertically.

(f) Remove the two switch shafts by first loosening and removing the six 2-56 x 1/4 pan head screws (3 per plate) from the triangular-shaped switch retaining plates behind the shaft couplers (fig. 3-63). Carefully withdraw these two shafts by grasping the coupler and sliding them out through the front of the module.

CAUTION

Do not disturb the position of the switch rotors when withdrawing

these shafts. If the shaft sticks in a switch rotor, a slight rocking motion will free it so that it can be further withdrawn.

(g) Carefully lift the interconnected switch card assemblies (E6, E7, and E8) out of the module chassis as a unit through the bottom of the module chassis.

NOTE

If the interconnecting wire between card assemblies E4 and E5 has not been disconnected, unsolder this wire, withdraw it through the hold in the partition, and tag it carefully for reconnection later.

(h) Loosen and remove the four 4-40 x 1/4. flat head screws (2 per. side) that secure the partition (between E4 and E5) to the sides of the-module chassis; withdraw the partition through the bottom of the module chassis.

(i) Loosen and remove the four 4-40 x 7/8 pan head screws, their associated washers, and the four 1/2-inch spacers used to attach card assembly E5 to the bearing plate; carefully back the card off the stub shaft of the gear assembly and withdraw the card through the bottom of the module chassis.

(j) Individual card assemblies (E6, E7, and E8) may be serviced by disconnecting the interconnecting wires and disassembling the cards from one another.

NOTE

Disassemble these groups of cards only to the extent necessary to affect the required maintenance procedure.

(2) *Repair Procedures.* Replace any defective component or repair the circuit using the procedures outlined in section IV. Component parts shown in the module schematic diagram (fig. 7-14) are located in figures 3-54 through 3-63.

CAUTION

When using a soldering iron to remove or replace a component part, use only enough heat to cause solder to flow. Excess heat can damage the component and may also damage the printed circuit.

(3) *Reassembly Procedure.*

(a) Replace and solder any wires that were removed from the module connector or from individual card assemblies during disassembly or repair procedures.

(b) Verify that the switch rotors on card assemblies E5, E7 and E8 are in position no. 1 (fig. 3-62).

(c) Replace and solder the wires that interconnect card assemblies E6, E7, and E8, if this unit assembly was disassembled for maintenance or repair.

NOTE

Install all card assemblies through the bottom of the module chassis with the card notches toward the bottom of the module and the corner notches to the right hand side.

(d) Verify that the gear assembly (that drives the switch on card assembly E5) is also in the no. 1 position (against its maximum counterclockwise stop when viewed from the front of the module). If not, rotate the Geneva drive shaft that extends to the rear of the gear assembly until the stop is reached.

(e) Install card assembly E5 through the bottom of the module chassis and carefully slide the D-hold of the switch rotor on to the stub shaft that extends to the rear of the gear assembly.

(f) Carefully insert the four 4-40 x 7/8 pan head screws (with associated lock washer and flat washer in place) through the bearing plate and then install the 1/2-inch spacers before securing the corners of the card assembly.

(g) Install the unit assembly composed of switch cards E6, E7, and E8 as a unit, through the bottom of the module chassis into their respective slots (fig. 3-15).

(h) Orient the shaft couplers to agree with figure 3-63 and carefully insert these shafts into the switch rotors of card assemblies E7 and E8. (The gear shaft that drives card assembly E5 through the switch assembly has the drive end deeply slotted, the opposite shaft is not slotted on the end.)

CAUTION

Do not disturb the position of the switch rotors of card assemblies E7 and E8 when installing the drive shafts, improper switch operation and equipment damage can result.

(i) Install the triangular-shaped switch shaft retaining plates under each shaft coupling and secure each in place with three 2-56 x 1/4 pan head screws and associated lock washers (fig. 3-63).

(j) Insert card assemblies E4, TB1, and E2 in that order before installing card assembly E1 in its slot.

(k) Install the nylon cable clamp using the 4-40 x 3/16 flat head screw.

(l) Insert the metal partition between card assemblies E4 and E5 and secure it in place with the four 4-40 x 1/4 flat head screws (two per sides).

(m) Thread the interconnecting wire from E4 through the hold in the metal partition and attach and solder it to the proper terminal on card assembly E5 (fig. 3-14).

(n) Install the top cover with the 4-40 pan head screws; invert the chassis and install the bottom cover with the 4-40 x 1/4 flat head screws.

NOTE

Observe that the grounding fingers attached to the bottom cover properly engage the slotted portion of card assembly E1.

3-14. Power Amplifier (A8A4A1) Tube Removal and Replacement

(fig. 3-65 and 3-87)

WARNING

High voltages are present on circuit components associated with the power amplifier stage. These voltages are dangerous and can be fatal. Before beginning tube replacement, ground the two high-voltage terminals (J1-A1 and J1-A2) on the main chassis to discharge the filter capacitors in this equipment.

a. Removal.

(1) Loosen the four 8-32 x 1/2 flat head screws and remove the access cover (fig. 3-87) from the front of RT-671 /PRC-47. Do not damage the gasket when removing the access cover.

(2) Loosen and remove the 4-40 x 1/4 pan head screws that secure the bottom cover to the power amplifier compartment; remove this cover.

(3) Loosen and remove the two 4-40 x 1/8 pan head screws that secure overtemperature cutout K103 to the power amplifier tube heat sink (fig. 3-65); remove K103.

(4) Remove the plate cap from V101 and push its attached lead into the power amplifier compartment through the clearance hole in the side of the heat sink.

(5) Grasp the tube at its base and disengage it from its socket. Withdraw the tube and the heat sink together through the access hole in the front panel of the receiver-transmitter.

(6) Place a soft pencil mark on the heatsink opposite the oversize pin on the base of the power amplifier tube. Gently pull the heat sink from around the tube.

b. Replacement.

(1) Insert a new power amplifier tube in the heat sink using care to observe the orientation of the oversize pin on the tube base.

(2) Insert the tube and its heat sink through the front panel access hole and press the tube firmly in to its socket.

NOTE

Carefully rotate the heatsink around the axis of the power amplifier tube until its mounting holes match the holes in the front panel of the receiver-transmitter.

(3) Thread the plate cap and its lead through the clearance hole in the heat sink and carefully attach it to the plate electrode.

(4) Position the overtemperature cutout on the heat sink and carefully secure it in place with the two 4-40 x 1/8 pan head screws.

(5) Orient the access hole cover and its gasket on the opening in the front panel of the RT-671/PRC-47 and secure them in place with the four 8-32 x 1/2 flat head screws.

NOTE

This cover should be positioned so that the attached chart can be easily read.

(6) Replace the bottom cover on the power amplifier compartment and secure it in place with the 4-40 x 1/4 pan head screws.

3-15. Power Amplifier Load and Tune Mechanism (fig-3-89)

CAUTION

Disassemble the load-tune mechanism only to the extent necessary to affect repairs. Use extreme care to avoid damage or misalignment of roller spring assemblies 139), (45), (60), 174), (86), and 188).

a. Disassembly Procedures.

(1) Loosen and remove the 4-40 x 1/4 screws (11 per cover) that secure the top and bottom covers to the power amplifier compartment; remove both covers.

(2) Remove E-ring (17) from its groove in the shaft of LOCK knob (15) and unscrew the knob from stud (18). Open dial stop (14).

(3) Loosen setscrews (2) and (20) and remove POWER AMPLIFIER LOAD control knob (1) and POWER AMPLIFIER TUNE control knob (21) from their respective shafts.

(4) Remove screws 14), (5), (23), and (24); then remove pointers (6) and (25). Withdraw primary scales (3) and (22) from collars (7) and (26).

(5) Loosen and remove collars (7) and (26); then remove secondary scales (8) and (27).

(6) If panel bushings (9) and (28) are defective, remove them from the front panel of RT-671/PRC-47 as follows:

(a) Loosen and remove hex nuts (68) and (99).

(b) Withdraw panel bushings (9) and (28) from the front panel. Use care so that gaskets (10) and (29) and nylon sleeve bearings (69) and (95) are not lost or damaged.

NOTE

Be sure that washers (67) and (100) remain on the shafts of inductors (64) and (101) respectively.

(7) Unsolder and tag the two insulated bus wires that connect to lower front contact spring assembly (74).

(8) Carefully remove roller contacts (41), (56), (82), and (91) and their associated rods (42), (51), (79), and (92) by removing 0-80 x 1/8 round head screws (38), (44), (49), (57), (76), (85), (90) and (94) and their associated washers.

(9) Remove E-ring (98) and spur gear (96) from stub shaft (97).

(10) Perform the procedures of paragraph 3-19 a and carefully remove the front panel of the receiver-transmitter so that sleeve bearings (35), (48), (69), and (95) remain on their respective shafts.

(11) If dial stop (14), support plate (12), lower front mounting block (73) or lower front contact spring assembly (74) are defective, remove them as follows:

(a) Remove lower front contact spring assembly (74) from lower front mounting block (73) by removing 6-32 x 1/4 net head screws (77) and (78).

(b) Remove the dial stop assembly and lower front mounting block (73) from the panel of the receiver-transmitter by removing 6-32 x 7/16 flat head screw (13) and stud (18).

NOTE

If either dial stop (14) or support plate (12) is defective, replace this assembly as a unit.

(12) If upper front contact spring assembly (45) or upper front mounting block (46) is defective, proceed as follows:

(a) Remove the four 4-40 x 1/2 pan head screws that secure XMTR OUTPUT meter to the front panel of the receiver-transmitter. Carefully withdraw the meter so that its gasket is not damaged. Do not unsolder the meter leads.

(b) Remove 6-32 x 5/16 flat head screws (31) and (32) that secure upper front mounting block (46) and upper front contact spring assembly (45) to meter shield (33).

(c) Carefully remove upper front contact spring assembly (45) from upper front mounting block (46) by removing 6-32 x 1/4 flat head screws (52) and (53).

(d) Remove meter shield (33) from the

back of XMTR OUTPUT meter compartment by removing 4-40 x 1/4 flat head screws (34) and (47).

CAUTION

Use extreme care when removing inductors (36), (64), (70) and (101) to prevent damage to side contact spring assemblies (60) and (86).

(13) Carefully withdraw POWER AMPLIFIER LOAD inductor (64) from gear plate (117) being careful not to damage sleeve bearing (84) or to lose washer (67).

(14) Remove POWER AMPLIFIER TUNE inductor (101) as follows:

(a) Loosen screw (102) in shaft collar (103) until the collar moves freely on the inductor shaft.

(b) Hold the shaft collar as inductor (101) is withdrawn from sleeve bearing (106).

(15) Remove 6-32 x 1/4 flat head screw (115), washer (116) and associated shims and carefully withdraw inductor (36) from gear plate (117) so that sleeve bearing (37) is not damaged.

(16) Remove 6-32 x 1/4 flat head screw (110), washer (111) and associated shims and carefully withdraw inductor (70) from gear plate (117) so that sleeve bearing (59) is not damaged.

(17) Remove side contact spring assemblies (60) and (86) by carefully removing 6-32 x 5/16 flat head screws (112) and (109) respectively.

(18) Loosen and remove 6-32 x 5/16 flat head screws (113) and (114) and carefully withdraw upper roller spring assembly (39) and upper rear mounting block (40).

(19) Remove upper rear mounting block (40) from upper roller spring assembly (39) by removing 6-32 x 1/4 flat head screws (54) and (55).

(20) Remove E-ring (63) and gear and stop assembly (62) from stub shaft (61).

(21) Remove lower roller spring assembly from mounting block (87) by loosening and removing 6-32 x 1/4 flat head screws (80) and (81).

(22) Remove gear plate (117) by loosening and removing the six 6-32 x 1/4 pan head screws that secure the gear plate to the rear wall of the power amplifier compartment.

(23) Remove lower rear mounting block (87) from gear plate (117) by removing 6-32 x 5/16 flat head screws (107) and (108).

b. Repair Procedures.

(1) Examine all items of the disassembled power amplifier load and tune mechanism for damage and excessive wear. Replace those items that are defective.

NOTE

Items most subject to wear and breakage include coil windings, gear teeth, inductor rollers, roller rods, sleeve bearings, inductor shafts and nylon mounting blocks.

(2) Lubricate the rollers of the power amplifier load and tune inductors only if they squeak. Place one or two drops of Beacon #325 lubricant on each roller rod, then wipe the entire rod with a clean soft cloth. Sufficient oil film will remain on the rod to adequately lubricate the roller.

CAUTION

Do not over-lubricate. Malfunction of roller contacts, arcing, and damage to adjacent components in the power amplifier compartment can occur.

c. *Reassembly Procedures.* Reassembly procedures are detailed in three specific areas: the components mounted directly to the rear of the power amplifier compartment (gear plate, rear contact spring assemblies, side contact spring assemblies, etc.), the components associated with the four inductors (sleeve bearings, shaft collars, gears, etc.), and finally the reassembly of the front panel to the power amplifier load and tune mechanism. Depending upon whether total disassembly was necessary, some steps of the following procedures may be omitted.

(1) Attach lower rear mounting block (87) to gear plate (117) with 6-32 x 5/16 flat head screws (107) and (108) and tighten them securely.

(2) Attach gear plate (117) to the rear wall of the power amplifier compartment with the six 6-32 x 1/4 pan head screws; tighten them securely.

(3) Install gear and stop assembly (62) on stub shaft (61) and secure it in place with E-ring (63).

(4) Install lower rear roller spring assembly (88) on mounting block (87) with 6-32 x 1/4 flat head screws (80) and (81).

(5) Install upper roller spring assembly (39) on mounting block (40) with 6-32 x 1/4 flat head screws (54) and (55).

(6) Install the spacer-contact spring assembly (step 5) to gear plate (117) by securing upper mounting block (40) with 6-32 x 5/16 flat head screws (113) and (114).

(7) Install side contact spring assemblies (60) and (86) to gear plate (117) and secure them in place with 6-32 x 5/16 flat head screws (112) and (109) respectively.

(8) Install sleeve bearings (37), (59), (84), and (106) in gear plate (117).

(9) Carefully insert the shaft of inductor (36)

into sleeve bearing (37) and mesh the gear with idler gear (62) and side contact spring assembly (60). Install 6-32 x 1/4 flat head screw (1115), washer (116), and sufficient shims to provide 0.010 to 0.013 inch clearance between the gear face and the sleeve bearing (37).

(10) Rotate inductor (36) counterclockwise (from the front panel end of inductor shaft) until the gear stops are oriented as shown in detail A of figure 3-89.

(11) Carefully install inductor (64) in sleeve bearing (84) and mesh the shaft gear with idler gear (62) and the lower contact of side contact spring assembly (60).

NOTE

Align the scribe marks on idler gear (62) and the gear of inductor (64) as shown in detail A of figure 3-89.

(12) Carefully install inductor (70) in sleeve bearing (59) and mesh the shaft gear with idler gear (62) and side contact spring assembly (86). Align the scribe mark on the gear of inductor (70) with the scribe mark on idler gear (62) as shown in detail A of figure 3-89. Install 6-32 x 1/4 flat head screw (110), washer (111), and sufficient shims to provide 0.010 to 0.013 inch clearance between the gear face and sleeve bearing (59).

(13) Install shaft collar (103) on the rear extension of inductor (101); do not tighten. Carefully install the inductor in sleeve bearing (106) so that the lower contact of side contact spring assembly (86) is properly seated and the shaft collar is against sleeve bearing (106).

(14) Install shaft collar (72) and washer (67) on the front extension of inductor (64); do not tighten. Install washer (100) on the front shaft extension of inductor (101).

(15) Install vernier drive panel bushings (9) and (28), with gaskets (10) and (29), into the front panel (30) and secure in place with hex nuts (68) and (99) respectively.

(16) Install sleeve bushings (69) and (95) in vernier dial panel bushings (9) and (28) respectively through the back of the panel.

(17) Install sleeve bearings (35) and (48) in meter shield (33); then attach the meter shield plate to the back of XMTR OUTPUT meter compartment with 4-40 x 1/4 flat head screws (34) and (47).

(18) Attach mounting block (46) to meter shield (33) with 6-32 x 6t16 flat head screws (31) and (32); then replace the XMTR OUTPUT meter and its gasket on the front of the receiver-transmitter and secure it in place with four 4-40 x 1/2 pan head screws.

(19) Attach lower front mounting block (73) and the dial LOCK assembly to the front panel with 6-32 x 1/2 flat head screw (13) and stud (181).

(20) Perform the remaining procedures of paragraph 3-19c and then carefully install the front panel so that the shafts of inductors (64) and (101) extend through sleeve bearings (69) and (95) respectively, and shafts of inductors (36) and (70) are inserted in sleeve bearings (35) and (48) respectively.

(21) After securing the front panel in place on the main chassis, adjust shaft collars (72) and (103) so that the clearance between the shaft collar face and its associated sleeve bearing is 0.010 to 0.013 inch. Tighten them securely.

(22) Install idler gear (96) on stub shaft (97) and secure it in place with E-ring (98).

(23) Rotate POWER AMPLIFIER TUNE control shaft until the stop on inductor (101) is against the stop on idler gear (96) as shown in detail B of figure 3-89. If idler gear (96) cannot rotate one complete revolution away from its stop, remove E-ring (98) and remesh idler gear (96) one tooth away from the stop.

(24) Attach contact spring assembly (45) to upper front mounting block (46) with 6-32 x 1/4 flat head screws (52) and (53); then attach contact spring assembly (74) to lower front mounting block (73) with 6-32 x 1/4 flat head screws (77) and (78). Use extreme care not to strip the threads in the mounting blocks by tightening these screws too tightly.

(25) Solder the two insulated bus wires that connect to the lower front contact spring assembly (74) and apply a liberal amount of epoxy insulating cement to each contact after the solder has cooled.

(26) Install roller contacts (41), (56), (82), and (91) on rods (42), (51), (79), and (92) respectively and secure them in place with 0-80 x 1/8 round head screws (38), (44), (49), (57), (76), (85), (90) and (94) and their associated washers.

NOTE

With POWER AMPLIFIER TUNE and POWER AMPLIFIER LOAD inductors against their stops, place the roller contact of each inductor on the rear turn of its associated coil.

(27) Install secondary vernier scales (8) and (27) and secure in place with collars (7) and (26) respectively.

(28) Install scales (3) and (22) on collars (7) and (26) and then attach pointers (6) and (25) to the secondary scales with 1-72 x 1/8 round head screws (4), (5), (23), and (24).

(29) Install knobs (1) and (21) on their respective inductor shafts. Hold the inductors

against their stops and rotate scales (3) and (22) using knobs (1) and (21) respectively so that the index marks are at 0; then tighten setscrews (2) and (20).

NOTE

Repeat step (29) until both controls are set at 0 when the inductors are against their respective stops.

(30) Insert LOCK knob (15), with washer (16) attached, into the hole in dial stop (14) and screw the knob into place on stud (18). Then install E-ring (17) in the groove of the LOCK knob shaft.

3-16. Frequency Selection Mechanism
(fig. 3-90)

a. Disassembly Procedures.

NOTE

Disassemble the frequency selection mechanism only to the extent necessary to accomplish repair or maintenance. Before beginning, set the KILOCYCLES indicator on the front of the receiver-transmitter to 2000.

(1) Remove Signal Data Translator CV-1377A/PRC-47 (A3) and Oscillator Control C. 4311/PRC-47 (A7) from their locations in the RT. 671/PRC-47 using the procedures of paragraph 3-126

(2) Loosen setscrews 12), (4), and (6), two per knob, and remove frequency control knobs (1),(3), and (5) from their shafts.

(3) Loosen and remove 6-32 x 3/8 pan head screws (102), (108),(119),(134), and (137) and washers (101), (107), (118), (132),1133), and (136) that attach the gear plate (103) to sleeve nuts (25),(39),(42), (75), and (100).

NOTE

Before proceeding, dress the cable away from the back of the gear plate as far as possible so that the gear plate can be withdrawn sufficiently to disengage the center frequency-control shaft (78).

(4) Carefully withdraw gear plate (103) from the shoulders of sleeve nuts no. 2 (42) and (100) to provide access to all gears and gearshaft assemblies.

NOTE

When withdrawing the gear plate, do not lose flat washer (27); it may adhere to sleeve bearing (26). Place this washer on spur gearshaft (28) for future installation.

(5) Remove idler gears (18), (29), (37), and (43) only if the gear or its stub shaft 114),(15), (17), or (135) is defective. Remove E-ring (19) (30), (38), or (144) to remove the defective idle; gear.

NOTE

Stub shaft (35), in addition to being pressed into the front panel of the receiver-transmitter, is secured in place by 6-32x 5/16 flat head screw (10) that is accessible by removing the front panel unit nameplate.

(6) Bevel gear assemblies (24) and (65) are removable by withdrawing either shaft out of the rear of the panel until it is removed from panel bearing (23) or (66). Do not remove retaining rings (89) or (64) unless these bearings are defective.

CAUTION

Do not attempt to disassemble gear-shaft assemblies that are pinned together. If either the gear or the shaft is defective, replace the entire assembly as a unit.

(7) Loosen and remove 6-32 x 1/2 flat head screws (7),(18), (9), (11), and (12) to remove sleeve nuts (25), (39), (42), (175) and (100).

NOTE

Sleeve nuts (42) and (100) have shoulders provided to index the mounting holes in gear plate (103) for alignment.

(8) Remove panel bearings (23), (66), and (79) only if they are defective. Whenever any one of these panel bearings is replaced, replace gasket (221 (67), and/or (80) with it.

(9) The spur gear-pinion assembly consisting of gear (72), shaft collar (70), bearing (68), and gearshaft (127) is removed by pressing the pinion end of the shaft through the gear plate. Further disassembly of this spur gear-pinion assembly is performed as follows:

(a) Remove washer (73) from the end of the shaft.

(b) Loosen setscrews (71) in shaft collar (70) and withdraw spur gear (72) from the shaft.

(c) Remove shaft collar (70) from the shaft and release C-ring (69).

(d) Remove panel bearing (68) from the pinion shaft.

NOTE

If either the pinion or its gearshaft (127) is defective, replace the pinion-gearshaft assembly as a unit.

(10) Remove the center frequency-control gearshaft assembly (78) as follows:

(a) Release pawl spring (111) from eye

(b) Remove E-ring (124) from stub shaft (122) and rotate gear and stop assembly (123) until it can be removed from the stub shaft.

(c) Remove setscrew (126) from gear and

stop assembly (125) and withdraw the gear assembly from shaft (78).

(d) Withdraw gearshaft assembly (78) toward the front side of gear plate (103)

NOTE

C-ring (77) and bearing (76) need not be removed from the gearshaft assembly unless one of them is defective.

(11) Remove frequency indicator assembly 148 from gear plate (103) by removing 4-40 x 5/16 pan head screws (116), (121), and (130) with washers (115), (120), and (129).

NOTE

Do not attempt disassembly of frequency indicator assembly (48). Except for bevel gear (47), this assembly must be replaced as a unit.

(12) Remove gearshaft-coupler assembly (128) as follows:

(a) Remove C-rings (32) and (33) from their grooves.

(b) Withdraw gearshaft-coupler assembly (128) from bearing (34).

(13) Remove coupling half no. 2 (114) from gear plate (103) as follows:

(a) Loosen setscrews (86) in shaft collar (83) and withdraw pinion (28) from the shaft of coupling half 1114).

(b) Remove shaft collar (83) from the shaft; remove washer (82); then remove coupling half (114) from sleeve bearing (81).

(14) Remove coupling half no. 1 (106) and coupling half no. 3 (135) from gear plate (103) as follows:

(a) Release pawl springs (97) and (56) from eye screws (87) and (57) respectively.

(b) Remove coupling half no. 1 (106) by loosening setscrews (96), two per collar, and withdraw spur gear (21), shaft collars (92) and (93), and spur gear detent (91) from the shaft.

(c) Remove coupling half no. 3 (135) by loosening setscrews (621), two per collar, and withdraw spur gear 141), shaft collars (60) and (61), and spur gear detent (59) from the shaft.

(d) Withdraw coupling halves (106) and (135) from the associated sleeve bearing, (90) or (158), by pulling toward the rear of the unit.

(15) Pawls (54), (98), and (110) are removed from gear plate (103) as follows:

(a) Release pawl springs (56), (97), and (111) from their respective eye screws (57), (87), and (117).

(b) Remove snap rings (53), (95), and 1113) from posts (52), (94), and (112); then remove pawls 154). (98), and (110) from the posts.

(c) Posts (52), (94), and (121 are removed from gear plate (103) by removing hex nuts (138), (105), and (85) together with washers (138), (104), and 184).

(d) Pawl springs (56), (97), and (111) are removed from the associated pawl by removing spring pins (55), (99) and (109) respectively.

b. Repair Procedures.

(1) Examine all parts of the disassembled frequency selection mechanism for damage or excessive wear. Particular attention should be directed to the condition of gear teeth, bearings, sleeve bearings, and springs. Replace any part that appears defective.

(2) Do not lubricate any gears or bearings. These parts are permanently lubricated and over-lubrication can damage the part or cause malfunction of other adjacent components.

(3) Whenever the panel bearings (23), (66), or (79) are replaced, replace gaskets (22), (67), and/or (80) also. This will assure the splash-proof condition of the equipment.

c. Reassembly Procedures.

Reassembly procedures are detailed in three parts: the components mounted directly to the front panel (idler gears, stub shafts, etc.), the components associate with the gear plate (frequency indicator assembly, detents, pawls, springs, etc.), and the reassembly of the gear plate to the front panel. Depending upon whether total disassembly of the geartrain was required, some steps of the following procedure may be omitted.

(1) Whenever panel bearings (23), (66), or 179) are replaced, insert gaskets (22), (67) and/or (80) into the bearing housing and press them flat before inserting the bearing.

(2) Replace idler gear stub shafts (14), (15), (17), and (35) only if they are defective. Press the replacement shaft into place on the front panel; secure stub shaft (35) with 6-32 x 5/16 flat head screw (10).

CAUTION

Never press stub shafts or panel bearings into the front panel without first removing all panel-mounted components that could be damaged by this procedure. Protect the finish of the front panel while installing these shafts: retouch wherever necessary.

(3) Install idler gears (18). (29), (37). and (431 on their stub shafts and secure with E-rings (19), (30), (38) and (44) respectively.

(4) Install sleeve nuts (25), (39), (42), (75), and (100) at their proper locations and secure them in place with 6-32 x 1/2 flat head screws (7), (8), (9), (11), and (12).

NOTE

Sleeve nuts (42) and (100) have shoulders on them; be sure that they are installed in the proper location to provide proper alignment for the gear plate.

(5) Replace E-ring (89) in the groove near the end of bevel gear assembly (24); then insert the opposite end of this gear assembly into bearing (23) from the rear until the gear face rests against the bearing race and meshes with idler gear (18).

(6) install C-ring (64) in the groove near the rear end of the bevel gear assembly (65); then install bearing 163) against this C-ring. Insert the bevel gear assembly into bearing 166) from the rear, but do not mesh this gear with gear and stop assembly (37).

NOTE

Rotate gear and stop assembly 137) counterclockwise until stop (36) rests against the top of roll pin (16). Return the gear clockwise two gear teeth away from the stop and hold in this position while performing the next step.

(7) Rotate bevel gear assembly 165) until one flat on the knob end of the shaft is to the right (as viewed from the front of the panel) and the other is toward the bottom. Then mesh the spur gear of bevel gear assembly 165) with gear and stop assembly 137).

(8) Pawls (54), 198). and (110) are installed in their respective locations on the gear plate as follows:

(a) Install posts (52), (94), and (112) on gear plate (103) and secure in place with hex nuts (139), (105), and (85) together with washers (138), (104), and (84) respectively.

(b) Install pawls (54), (981), and (110) on their respective posts and secure in place with snap rings (53), (95), and (113).

(c) Pawl springs (56), (97), and (111) are secured to the pawls with spring pins (55), (99), and (109) respectively.

(9) Coupling half no. 1 (106) and coupling half no. 3 (135) are attached to the gear plate as follows:

(a) Insert sleeve bearings (58) and 190) into the gear plate (103) from the front side.

(b) Insert the shaft of coupling half no. 1 (106) through sleeve bearing (90); then install spur gear detent (91) and shaft collar (92); secure in place by tightening setscrews 196)

(c) Install shaft collar (93) on the shaft of coupling half no. 1 (106) and install spur gear no. 2 (21). Tighten setscrews (96) to secure the shaft collar /93) to the shaft.

(d) Insert the shaft of coupling half no. 3 (135) through sleeve bearing (58); then install spur gear detent 159) and shaft collar (60); secure in place by tightening setscrews 162).

(e) Install shaft collar (61) on the shaft of coupling half no. 3 (135) and then install spur gear (41). Tighten setscrews (62) to secure the shaft collar in place.

(f) Hook the free end of pawl springs (56) and /97) in eye screws (57) and (87).

(10) Insert gearshaft-coupler assembly (128) through gear plate (103) from the rear; then install bearing (34) on the shaft of this assembly. Secure the bearing in place with C-ring (33) and then install C-ring (32) in the remaining groove near the end of the shaft.

(11) Assemble spur gear-pinion assembly as follows:

(a) Install bearing (68) on pinion shaft (127) and secure in place with C-ring (69).

(b) Install shaft collar (70) on the shaft of spur gear 1127); then install spur gear no. 4 (72) on the shaft but under the collar. Tighten setscrews (71) to secure the spur gear to the pinion shaft.

(12) Install the spur gear-pinion assembly (step 11) in gear plate (103) from the front side being careful to mesh pinion (127) with gearshaft-coupler assembly 1128).

(13) Replace the center frequency-control shaft assembly as follows:

(a) Install C-ring (77) on gearshaft assembly (78); then install bearing (76) against the C-ring.

(b) Insert gearshaft assembly (78) into the gear plate (103) so that bearing (76) seats properly.

(c) Install gear and stop assembly (125) on the outboard end of gearshaft assembly (78) with the detent nearest the gear plate. Align the setscrew hole in gear and stop assembly (125) with the countersink in the shaft and tighten setscrew (126) securely.

(d) Rotate the center frequency-control shaft clockwise (as viewed from the front of the panel) until gear and stop assembly (123) can be installed on stub shaft (122). Secure it in place with E-ring (124).

(e) Rotate the center frequency-control shaft counterclockwise until gear and stop assemblies (123) and (125) are at their stops.

(f) Install the free end of pawl spring (111) into eye screw (117). As the pawl indexes the spur gear detent of gear and stop assembly (125), the stops of gear and stop assemblies (123) and (125) will part slightly.

NOTE

Proper assembly is achieved when only 1/4 detent position is possible as the center frequency-control shaft is rotated counterclockwise; several turns of this shaft are possible in the clockwise direction.

(14) Assemble gearshaft-coupling half no. 2 as follows:

(a) Install sleeve bearing (81) in gear plate (1031 and insert the shaft of coupling half no. 2 (114) into this bearing.

(b) Install washer 182) on the shaft; then install shaft collar (831. Install spur gearshaft (28) and the shaft and secure the assembly by tightening setscrews (86).

(15) If bevel gear (47) has been removed from the kilohertz drive shaft of frequency indicator assembly (48), install this gear and secure it in place with setscrews 146).

(16) Install frequency indicator assembly 148) on the gear plate so that the pins in the frequency indicator assembly index the holes in the gear plate. Secure in place with screws (116), (121), and (130) with washers (115), (120), and (129). (17) Install sleeve bearings (20), (26), and (40), and ball bearings (31) and (74) into the rear of the front panel.

(18) Install the gear plate, with shafts, to the back of the panel as follows:

(a) Position coupling half no. 1 (106) and coupling half no. 3 (135) so that the bosses on each coupling face are vertically oriented within 0.5 angular degree.

NOTE

Loosen shaft collars (60) and/or (92) to obtain adjustment of the vertical orientation of these coupling halves. Tighten the setscrews securely when they are properly adjusted.

(b) Rotate bevel-spur gear assembly no. 1 (65) until idler (37) is against its stop.

(c) Rotate frequency indicator assembly (48) until the digit wheels read 2000. Maintain this reading during the remainder of this procedure.

CAUTION

Exercise extreme care when installing the gear plate assembly. Gear teeth or nylon gears can be damaged if they are improperly meshed during assembly.

(d) Carefully insert center gearshaft assembly (78) into panel bearing (79).

(e) Maintain the bosses on the face of coupling half no. 2 (114) and on gearshaft-coupler

assembly (128) vertically oriented, and carefully insert the front end of these shafts into their respective sleeve bearings.

NOTE

After spur gearshaft (28) meshes with idler gear 129), but before the pinion shaft extension engages sleeve bearing 126), install flat washer (27) on the end of the gearshaft.

(f) Continue to insert the gearshafts into their sleeve bearings and rock the three front panel shafts and individual idler gears until all gears mesh and gear plate (103) is firmly seated on the shoulders of sleeve nuts (42) and (100).

(g) Check the KILOCYCLES indicator for proper wheel alignment at reading 2000. If any digit is misaligned, adjust bevel gear (47) or idler gears of the gear train.

(h) Secure the gear plate to the sleeve nuts with 6-32 x 3/8 pan head screws (102), (108), (119), and (137) with washers (101), (107), (118), and (136).

NOTE

Cable clamp (131) is secured with gear plate (103) to sleeve nut (39) with 6-32 x 3/8 pan head screw (134) and washers (321) and (133). During installation, dress the cable close to the gear plate to prevent interference with the coupling of Signal Data Translator CV-1377A/PRC-47.

(19) Assure that the faces of coupling halves. (106), (114) and (135) are within the dimensional tolerances shown in figure 3-88. If adjustment is required, loosen the setscrews in shaft collars (92) and (93), (83), or 160) and (61) to permit the couplings to slide in or out on the axis. Tighten all setscrews securely when proper alignment is obtained.

NOTE

The setscrews in the shaft collars are accessible from the underside of the RT-671/PRC-47 with modest rotation of the kilohertz and megahertz frequency-control shafts. Exercise care to maintain the boss orientation of the coupling halves. during this adjustment. Always recheck to assure that they are vertically oriented within 0.5 angular degree when the KILOCYCLES indicator is adjusted to 2000.

(20) Align the power amplifier plate capacitor switch to agree with the instruction in paragraph 3-17 c(11).

3-17. Power Amplifier (A8A4A1) Plate Capacitor Switch Assembly (fig. 3-91)

a. *Disassembly Procedures.* Disassemble the power amplifier plate capacitor switch assembly only to the extent necessary to accomplish the needed repair.

(1) Remove the top and bottom covers from the power amplifier compartment by removing the 4-40 x 1/4 screws that secure these covers in place.

(2) Remove the front panel covers to which the POWER AMPLIFIER LOAD-TUNE chart is attached by removing the four 6-32 x 3/8 flat head screws that secure it in place.

CAUTION

Exercise extreme care not to damage the rubber gasket that is used with the POWER AMPLIFIER LOAD-TUNE chart cover.

(3) Rotate the megahertz frequency-control shaft from the front panel to gain access to the setscrews of shaft collar (10). Loosen setscrews (9).

(4) Carefully withdraw fiber switch shaft (12) from the switch assembly through the access opening in the front panel, and remove shaft collar (10), spur gear (8), and washer (7) as it is withdrawn. If sleeve bearing (6) is loose in its housing, remove this part to prevent loss.

(5) Unsolder the insulated bus wire attached to capacitor (82); tag this bus wire.

NOTE

This lead connects the rotor of switch wafer (19) with the large transmitting-type capacitor (C122) mounted on the rear wall of the power amplifier compartment.

(6) Unsolder the shielded lead at the junction of capacitors (76) and (77). Loosen screw (30) and remove the shield and solder lug (29A) Install screw (30) and washer (29) and tag the shield.

(7) Unsolder the insulated bus wire attached to the TUNE inductor spring contact assembly. This connection is directly behind the POWER AMPLIFIER TUNE control knob and is accessible from the bottom of the power amplifier compartment; tag this wire.

(8) Remove the power amplifier tube access cover from the front of RT-671/PRC-47 by removing the four 8-32 x 1/2 flat head screws. Carefully remove the plate cap from this tube.

(9) Remove the two 6-32 x 1/2 flat head screws (1) and (3) that secure the plate capacitor switch assembly to the front panel.

(10) Loosen and remove hex nuts (107) and (108) with washers (106) and (109); withdraw two 4-40 x

5/16 flat head screws (104) and (106) and release bracket (86) from the side of power amplifier compartment (111).

(11) Carefully remove the switch assembly through the top of the power amplifier compartment.

(12) Disassemble the rear switch wafer-bracket assembly as follows:

(a) Unsolder insulated bus wire attached to solder lug (69).

(b) Remove 6-32 x 3/8 pan head screws (87) and (103) with washers (86) and (102) that secure bracket (85) to sleeve nuts (46) and (72).

(c) Remove sleeve nuts (46) and (72) and fiber washers (45) and (71) from studs (13) and (16); withdraw rear switch wafer (26) and bracket assembly (85) as a unit.

(d) To remove the capacitors from bracket (85), carefully remove solder lugs (43), (49), (53), (57), (61), (65) and/or (69) from capacitors (44), (50), (54), (58), (62), (66), and/or (70); then remove 6-32 x 1/4 pan head screws (89), (91), (93), (95), (97), (99), and/or (101) with associated washers.

(13) Disassemble the front switch wafer-capacitor plate assembly as follows:

(a) Withdraw sleeve nuts (5) and (11) from the heat deflector end of the switch assembly without removing studs (13) and (16).

NOTE

Exercise extremes in removing the studs to assure that sleeve spacers (14), (17), (21), and (24) and fiber washers (15), (18), (20), (22), (23), and (25) are not lost.

(b) To remove the capacitors from plate (73) carefully unsolder the capacitor pigtail before removing the attaching hardware. The 3-48 x 3/16 pan head screws (28), (30), (32), (34), (36), (38), and (40) with washers (27), (29), (31), (33), (35), (37), and (39) secure capacitors (78) through (84) to capacitor plate (73).

b. Repair Procedures.

(1) Examine all parts of the disassembled power amplifier plate capacitor switch assembly for damage or excessive wear. Particular attention should be directed to the panel sleeve bearing, drive gear teeth, switch contact fingers, and ceramic switch parts. Replace any component or part that is defective.

(2) Do not lubricate any gear, sleeve bearing, or switch contact in this assembly. Damage to other plate circuit components or circuit malfunction can occur if lubricants are used.

(3) Examine the rubber gasket used in conjunction with the access cover; replace this gasket if it is grossly deformed or broken.

c. *Reassembly Procedures.* Reassembly of the power amplifier plate capacitor switch assembly is detailed in two parts: the switch components and associated parts; and the installation of the assembled switch into its position in the power amplifier compartment. Depending on the amount of disassembly that was performed, and the component parts that were replaced, some steps of the following procedure may be omitted.

(1) Reassemble the front switch wafer-capacitor plate as follows:

(a) Attach capacitors (78) through (84) to plate (73) with screws (28), (30), (32), (34), (36), (38), and (40) using washers (27), (29), (31), (33), (35), (37), and (39). Solder capacitor pigtailed to the appropriate terminal of wafer (19).

(b) Tighten studs (13) and (16) in sleeve nuts (5) and (11).

(c) Insert studs (13) and (16) through plate (73), heat deflector (12), spacers (14) and (17), fiber washers (15) and (118), switch wafer (19), fiber washers (20) and (23), spacers (21) and (24), fiber washers (22) and (25), switch wafer (26), and fiber washers (45) and (71) into sleeve nuts (46) and (72); tighten the sleeve nuts snugly before attaching bracket (85). Secure the bracket in place with 6-32 x 3/8 pan head screws (87) and (103) using washers (86) and (102).

(2) Solder the insulated bus wire that passes through heat deflector (12) to solder lug (69).

(3) Carefully install the switch assembly through the top of the power amplifier compartment and secure it in place with two 6-32 x 1/2 flat head screws (1) and (3).

(4) Connect the shielded wire to the junction of capacitors (76) and (77) on plate (73), then secure the shield attached to soldering lug 29A under screw (30) and washer (29) and tighten.

(5) Install 4-40 x 5/16 flat head screws (104) and (105) through the side of power amplifier compartment (111) and secure bracket (85) with hex nuts (107) and (108) and lock washers (106) and (109).

(6) Solder the insulated bus wire attached to suppressor 1741 to the lower front contact spring assembly (fig. 3-89, item 74).

NOTE

Apply a liberal amount of epoxy insulating cement to this solder joint after it has cooled. This will lessen corona effects.

(7) Carefully attach the plate cap to the electrode of the power amplifier tube.

(8) Solder the insulated bus wire connected to the large transmitting capacitor (C122) on the rear wall of the power amplifier compartment to the center post of capacitor (82).

(9) Dress the two insulated bus wires and the power amplifier tube plate lead away from the load and tune inductors and from other metallic objects in the power amplifier compartment.

(10) Insert sleeve bearing (6) into the shaft hole from the rear of panel (4). Carefully install fiber switch shaft (2) through the panel and sleeve bearing (6); then assemble washer (7), spur gear (8), and shaft collar (9) on this shaft before inserting it in the rotors of switch wafers (19) and (26).

CAUTION

Rock the fiber shaft gently as it is inserted into the switch wafers to index the switch properly without damage.

(11) The shorting contacts of the switch rotors are oriented as shown in figure 3-91 when the KILOCYCLES indicator on the front of RT-671/PRC-47 reads 2000. Align these rotors properly before tightening setscrews (9) in shaft collar (10).

NOTE

The front face of spur gear (8) must be flush with the front face of the mating idler gear in the gear train before the shaft collar is secured in place.

(12) If no further effort is required in the power amplifier compartment, replace the top and bottom cover and secure them with the 4-40 screws.

3-18. Power Amplifier (A8A4A1) XMTR PWR Switch (fig. 3-92, 3-93)

a. *Disassembly Procedures.* Disassemble the power amplifier XMTR PWR switch assembly only to the extent necessary to accomplish repair.

(1) Remove the front panel of the receiver-transmitter using the procedures detailed in paragraph 3 19a.

(2) Loosen rubber grommets (26) and (42) from relay bracket (24); unsolder and tag the leads attached to switch wafers (56) and (73), and to resistor-switch subassembly (87): carefully withdraw the XMTR PWR switch.

(3) Disassemble the XMTR PWR switch as follows:

(a) Loosen and remove hex nuts (89) and (92), and net washers (88), and (91). Unsolder and tag resistors (65) and (74) from resistor-switch subassembly (187) and carefully remove the subassembly from screws (47) and (48).

(b) Remove flat washers (79) and (86) and

withdraw M ADJ shaft (72) from the switch shaft of detent (49).

(c) Unsolder and tag the wires at M ADJ potentiometer (90); then loosen and remove hex nut (8;) and lock washer (81).

(d) Remove nuts (77), (78), (84), and (85), net washers (76) and (83), fiber washers (50), (52), (53), (55), (62), (64), (68), (70), (75), and (82) with spacers (51), (54), (63), and (69). Carefully withdraw switch wafers (56) and (73) from screws (47), and (48).

(4) Remove relay bracket (24) from the power amplifier compartment as follows:

(a) Unsolder and tag the two wires connected to the outboard terminal of capacitor (40).

(b) Loosen and remove screws 193) and (94) and their associated hardware; then remove the relay bracket through the bottom of the chassis.

(c) The shielded receive antenna lead from relay (17) must be carefully unsoldered from the relay terminal and withdrawn through grommet (29) before cutting the lacing cord that secures it to the cable harness.

CAUTION

Use extreme care when working near relay (17). Excessive heat or rough handling can break the glass envelope of this relay.

(5) Remove rf transformer (12) as follows:

(a) Unsolder the insulated bus wire from the lower terminal of relay (17). Carefully straighten this wire and withdraw it from the small hole near the top of transformer (12).

(b) Carefully unsolder the rf detector leads (small wires) from the terminals near the bottom of the transformer.

(c) Remove attaching screws (14) and (15) with flat washers (13) and (16) that secure the transformer to relay bracket (24).

(6) Remove relay (17) by carefully unsoldering the wires from the base of the unit. Loosen hex nut (31) and remove lock washer (30).

NOTE

If the relay is defective, unsolder the antenna bus (short heavy wire) to which the solder lug is attached; save this bus wire for installation on the replacement relay.

(7) Defective piece parts attached to relay bracket (24), including capacitor (28), resistors (19) and (33), terminals (20), (32), and (41), and/or relay (59), may be unsoldered from their respective circuits, their

leads tagged, and then the attaching hardware (if any) removed.

b. Repair Procedures.

(1) Examine all parts of the disassembled XMTR PWR switch for damage or excessive wear. Particular attention should be given to switch shafts, ceramic switch parts, and contact fingers, potentiometer operation and hardware appearance. Replace any parts that show signs of damage, excess wear, or corrosion.

(2) Do not lubricate the switch contacts or detent. Damage to switch parts and adjacent circuits can result from lubrication of this assembly .

c. Reassembly Procedures. Depending on the amount of disassembly required and the parts that have been removed, some steps of the following procedure may be omitted.

(1) Replace, attach, and solder the piece parts to their respective circuits on the inside of relay bracket (24):

(a) Relay (59) is secured to the relay bracket with 4-40 x 1/4 pan head screws (18) and (34), lock washers (58) and (60) and hex nuts (57) and (61).

(b) Terminals (20), (32), and 141) are secured to their respective positions inside the relay bracket with 4-40 x 1/4 pan head screws (39), (25), and (35) respectively.

(c) Feed-thru capacitor (40) is secured to the rear wall of the relay bracket with hex nut (22) and lock washer (23); capacitor (28) is placed in clip (27) before soldering.

(2) Install relay bracket (24) in the power amplifier compartment and secure it to the side wall with 4-40 x 5/16 pan head screw (93), flat washer (94) lock washer (97) and nut (99).

(3) Insert the shielded wire (receive antenna) through grommet (29) and secure the shield (with lug 98 attached) with 4-40 x 5/16 pan head screw (94), flat washer (96), lock washer (100), and hex nut (101).

(4) Insert relay (17) in the large hole in relay bracket (24); orient the relay with the armature terminal to the right. Install lock washer (30) and secure in place with hex nut (31). Install and solder the leads on the base of the relay.

(5) Install transformer (12) to the top of relay bracket (24) and secure with 4-40 x 5/16 pan head screws (14) and (15) using flat washers (13) and (16). Attach the two rf detector leads (small wires) to the terminals near the bottom of the transformer; then pass the insulated bus wire through the small hole near the top of the transformer. Attach this bus lead to the normally open (lower) contact of relay (17) and carefully solder it. Dress this lead away from the envelope of relay (17) and then dress it downward on the opposite side of the transformer toward the front of the lower roller inductor.

(6) Install and solder the receive antenna lead (center of the shielded conductor) to the normally closed contact (left side) of relay (17). Attach the short insulated bus wire between the ANTENNA connector (bowl insulator) and the remaining contact of relay (17) if it has been removed.

(7) Reassemble the XMTR PWR switch (S103) as follows:

(a) Insert 4-40 x 2 1/4 round head screws (47) and (48) into detent (49); then install fiber washers (53) and (55), and spacers (51) and (54) on these screws.

(b) Install front switch wafer (56), fiber washers (62) and (68), spacers (63) and (69), fiber washers (64) and (70) and then install rear switch wafer (73).

(c) Install fiber washers (75) and (82), flat washers (76) and (83), and hex nuts (77) and (84). Tighten securely.

(d) Insert potentiometer shaft (72) into the shaft of detent (49).

(e) Install hex nuts (78) and (85), and flat washers (79) and (86) on the ends of screws (47) and (48); thread them onto these screws for a distance of about 5/8-inch.

(f) Insert potentiometer (90) into the hole near the center of resistor-switch subassembly (87); secure it in place with lock washer (81) and hex nut (80). Attach and solder the potentiometer leads.

(g) Install resistor-switch subassembly (87) on the ends of screws (47) and (48) until the slot in the potentiometer rotor mates with the boss on the end of the potentiometer shaft (72).

NOTE

Rotate the potentiometer shaft until the boss engages the slot in the rotor shaft of the potentiometer.

(h) Install flat washers (88) and (91) and hex nuts (89) and (92) on the ends of screws (47) and (48).

NOTE

Adjust hex nuts (78), (85), (89), and (92) until resistor-switch subassembly 187 is perpendicular to the axis of the SMTR PWR switch, and the rotor of potentiometer (90) turns freely as shaft (72) is rotated.

(i) Tighten the nuts against the outboard surface of resistor-switch subassembly (87).

(j) Connect the resistors and interconnecting leads between switch wafers and the

resistor-switch subassembly in accordance with the details shown on the connection diagram (fig. 3-93).

(8) Attach the leads of OPR-TUNE switch (44).

(9) Insert the SMTR PWR switch (S103) into the relay bracket and connect the tagged wires.

(10) Dress the cable harnesses neatly in grommets (26) and (42) and lace the harnesses, if required.

(11) Install the front panel of the receiver-transmitter using the procedures detailed in paragraph 3-19c.

3-19. Main Chassis and Front Panel Removal and Reassembly

(fig. 3-5, 3-87, 3-89 through 3-93)

a. Disassembly Procedures. No special procedures are required to remove piece parts from the main chassis of the receiver-transmitter. The leads of each defective electrical component must first be unsoldered and tagged, and then the mounting hardware removed. Remove the front panel and its associated parts from the main chassis using the following procedures.

(1) Perform the procedures for removal of the power amplifier load and tune mechanism detailed in steps (1) through (9) of paragraph 315a.

(2) Loosen and remove the two circular retaining nuts and hex nut that secure the AUDIO and POWER receptacles to the front panel.

(3) On the front of the receiver-transmitter, place the XMTR PWR switch to LO; the OPR-TUNE switch to OPR; the CW-FSK/VOICE switch to VOICE; the POWER-LIGHTS switch to POWER OFF; and rotate the M ADJ control to it' clockwise stop.

(4) Loosen the setscrews and remove the knobs from M ADJ, SMTR POOR, VOLUME and POWER-LIGHTS controls.

(5) Loosen and remove the hex nuts (and boots) that secure the OPR-TUNE, BATTERY TEST, and CW-FSK/VOICE switches to the front panel.

(6) Unsolder and tag the wires attached to POWER 20A DC and POWER 5A AC fuses, the four panel lamps, and SMTR OUTPUT meter.

(7) Remove the four 8-32 x 1/2 net head screws that secure the power amplifier tube access cover to the front panel; carefully remove the cover and its gasket.

(8) Remove the power amplifier tube using the procedures detailed in paragraph 3-14a.

(9) Loosen the pan head screw and carefully remove the bus wire and solder lug from the back of the ANTENNA connector (bowl insulator).

(10) Loosen and remove the four 6-32 x 3/8 flat head screws that attach the POWER AMPLIFIER LOAD-TUNE chart cover to the front panel of the receiver-transmitter.

(11) Refer to figure 3-91. Loosen setscrews (9) and withdraw fiber shaft (2), shaft collar (10), spur gear (8), and washer (7) from the plate capacitor switch assembly. Remove panel bushing (6) and then loosen and remove 6-32 x 1/2 flat head screws (1) and (3) that secure the switch assembly to the front panel.

(12) Loosen and remove the three 6-32 x 3/8 flat head screws that secure the relay bracket around the SMTR PWR switch assembly on the front panel of the receiver-transmitter.

(13) Loosen and remove the nine 8-32 x 1/2 pan head screws and the associated washers and nuts that secure the main chassis to bosses on the rear of the front panel (three screws at each end and three in the center).

(14) Cut the nylon lacing cord that secures the cable harness to the center boss at the extreme right end of the front panel.

(15) Carefully remove the front panel from the chassis assembly releasing individual components as the panel is slowly withdrawn.

(16) Remove any other panel-mounted components that are required to repair the front panel. (Disassembly of the frequency selection mechanism is detailed in paragraph 3-16.)

(17) Remove lower front contact spring assembly and upper front contact spring assembly using the detailed procedure listed in steps (11) and (12) of paragraph 3-15a.

b. Repair Procedures. Replace any defective panel-mounted component or individual piece part removed to affect repairs. Individual parts located in the main chassis should be replaced only if they are defective. Component parts are shown on the main chassis schematic diagram (fig. 7-8) and are located in figures 3-64 through 367.

CAUTION

When using a soldering iron to remove or replace component parts, use only enough heat to cause solder to flow. Excess heat can damage the component and may also damage its associated terminal or mounting board.

c. Reassembly Procedures.

(1) Install individual panel-mounted components that have been removed for repair. (See paragraph 3-16c for detailed assembly procedures of the frequency selection mechanism.)

(2) Perform all internal repair and reassembly procedures required by paragraphs 3-15 through 3-18

prior to attachment of the front panel to the main chassis or RT-671/PRC-47.

(3) Assemble the front panel to the main chassis as follows:

(a) Refer to figure 3-92. Bring the front panel close to the front of the main chassis and install OPR-TUNE switch (44) in its appropriate location using washers (45) and (46), and nut (3).

NOTE

Be sure that the key of washer (46) is properly seated in the pilot hole in the front panel before hex nut (3) is tightened.

(b) Carefully insert the shafts of XMTR POOR, POWER AMPLIFIER LOAD, and POWER AMPLIFIER TUNE controls, the shafts of the two upper load inductors, the AUDIO connector, VOLUME control, POWER-LIGHTS switch and POWER connector into their mounting holes; do not secure in place until instructed to do so.

NOTE

Before continuing this procedure, assure that the nylon bushings associated with the shafts of POWER AMPLIFIER LOAD and POWER AMPLIFIER TUNE controls are properly seated in the panel bushings.

(c) Install at least two of the 8-32 x 1/2 pan head screws in opposite ends of the main chassis side panels so that the front panel components can be secured in place easily; do not attach washers and nuts to these screws.

(d) Refer to figure 3-92. Install washer (8) and hex nut (6) on the shaft of X MTR PWR switch (S103) and tighten securely. Then install and tighten the 6-32 x 1/2 flat head screws (7), (9), and (10) that secure switch bracket (24) to the front panel.

(e) Install and tighten the circular nuts and hex nut that secure the AUDIO and POWER receptacles to the panel.

(f) Install the washer and hex nut that secures the VOLUME control and POWER-LIGHTS switch to the front panel; tighten them securely.

(g) Install the remaining 8-32 x 1/2 pan head screws in the side panels of the main chassis; secure all nine screws (3 at each end and 3 in the center) using the appropriate washers and nuts.

(4) Install the knobs on XMTR POOR, M A DJ, VOLU M E, and POW ER-L I G H TS controls. Orient each knob properly before tightening the setscrews.

(5) Connect the bus wire from the t/r relay to the ANTENNA connector (bowl insulator).

(6) Install the power amplifier tube using the procedure detailed in paragraph 3-14c.

(7) Replace the cover and rf gasket over the power amplifier tube access hole; secure in place with four 8-32 x 1/2 flat head screws.

(8) Solder the wires to POWER 20A DC and POWER 5A AC fuses, to the four panel lamp-, and to XMTR OUTPUT meter.

(9) Install BATTERY TEST pushbutton and CW-FSK/VOICE switch and secure each in place with the hex nut (boot).

(10) Refer to figure 3-91. Install 6-32 x 1/2 flat head screws (1) and (3) into spacers (5) and (11) of the power amplifier plate capacitor switch and tighten them securely; then install fiber shaft (2), panel bushing (6), washer (7), spur gear (8), and shaft collar (9) into the switch assembly.

NOTE

Rotate the frequency control knobs on the front panel of the receiver-transmitter to obtain a KILOCYCLES indicator reading of 2000; then orient the rotors of switch wafers (19) and (26) as shown in figure 391 before tightening the setscrews in the shaft collar.

(11) Install the access cover and gasket over the power amplifier plate capacitor access hole and secure it in place with the four 6-32 x 3/8 flat head screws. Do not damage the gasket used with this cover during installation.

(12) Perform steps (21) through (30) of the power amplifier load and tune mechanism procedures detailed in paragraph 3-15c.

(13) If all repairs are complete, install the top and bottom covers on the power amplifier compartment using the 4-40 screws (11 per cover).

Section VI. ALIGNMENT AND ADJUSTMENTS

3-20. Test Equipment and Special TOOTH Required for Alignment and Adjustments

a. The following test equipment and special tools are required for alignment and adjustments of Radio Set AN/PRC-47. Each type of test equipment is discussed below to point out its characteristics and use.

<i>Item</i>	<i>Technical manual</i>
Multimeter ME-26A/U	TM 11-6625-200-15
Oscilloscope AN/USM-50	TM 11-5129
Signal Generator SG-103/URM-25F	
Frequency Counter AN/URM-79/U	TM 11-6625-935-12
Audio Oscillator TS-382/U	
Dummy Load DA-75/U	
Cable Assembly Set AN/PRA-4	
Output Meter TS-585/1)	

b. *Multimeter ME-26A/U.* A vacuum-tube voltmeter used for general-purpose measurements.

c. *Oscilloscope AN/USM-50.* A visual display used for low-level measurements and audio waveform studies.

d. *Signal Generator SG-103/URM-25F.* A 10-kHz to 50-MHz signal generator used to provide intermediate frequency test signals for receiver evaluation tests.

e. *Frequency Counter AN/URM-79/U.* A frequency counting device used to establish the exact operating frequency of the signal generator.

f. *Audio Oscillator TS-382/U.* An audio oscillator with a range of 20-to 200,000-Hz and a maximum output of 100 milliwatts. Used as a signal source for audio inputs for transmitter tests.

g. *Dummy Load DA-75/U.* A 50-ohm rf load capable of dissipating 500 watts of rf power without external cooling. Used to terminate the transmitter output during transmitter tests.

h. *Output Meter TS-585/U.* A calibrated output indicating device with adjustable load. Used during measurements of audio output during receiver tests.

i. *Cable Assembly Set AN/PRA-4.* An assortment of extender cables for modules of the Radio Receiver-Transmitter RT-671/PRC-47, special test cables, and a special whip antenna simulator. Used whenever a module must be operated while removed from the main chassis of the receiver-transmitter, and during evaluation tests. The whip antenna simulator provides a miniaturized antenna system for bench testing the transmitter.

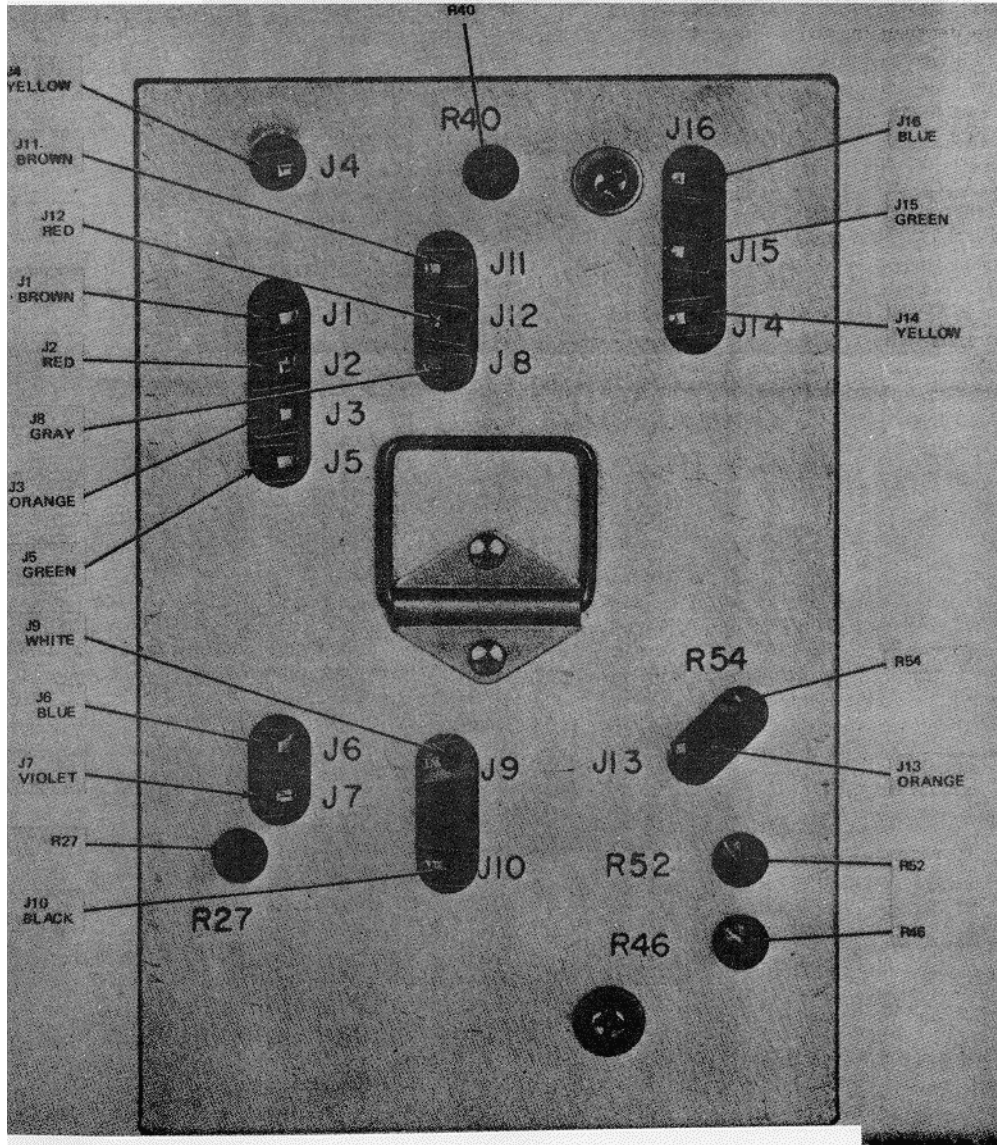

Figure 3-94. Audio Frequency Amplifier AM-3506/PRC-47 (A8A1), Top View, Location of Test Points and Adjustments.

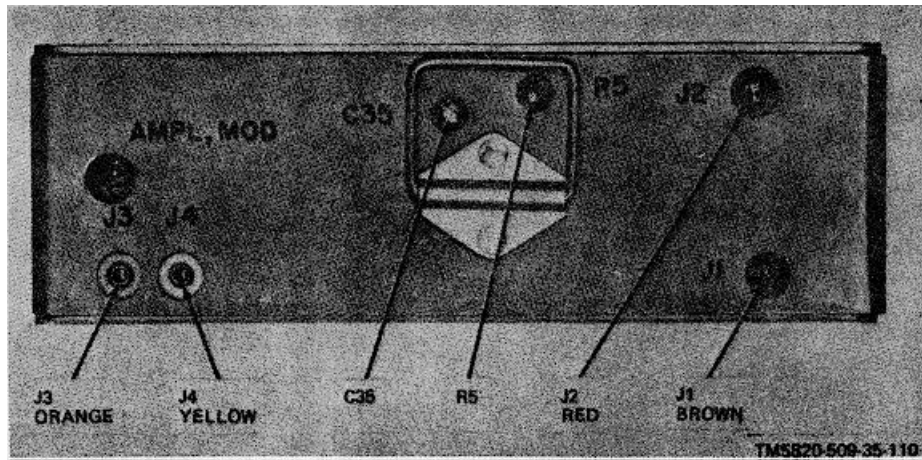

Figure 3-95. Amplifier-Modulator AM-3507/PRC-47 (A8A2), Top View, Location of Test Points and Adjustments.

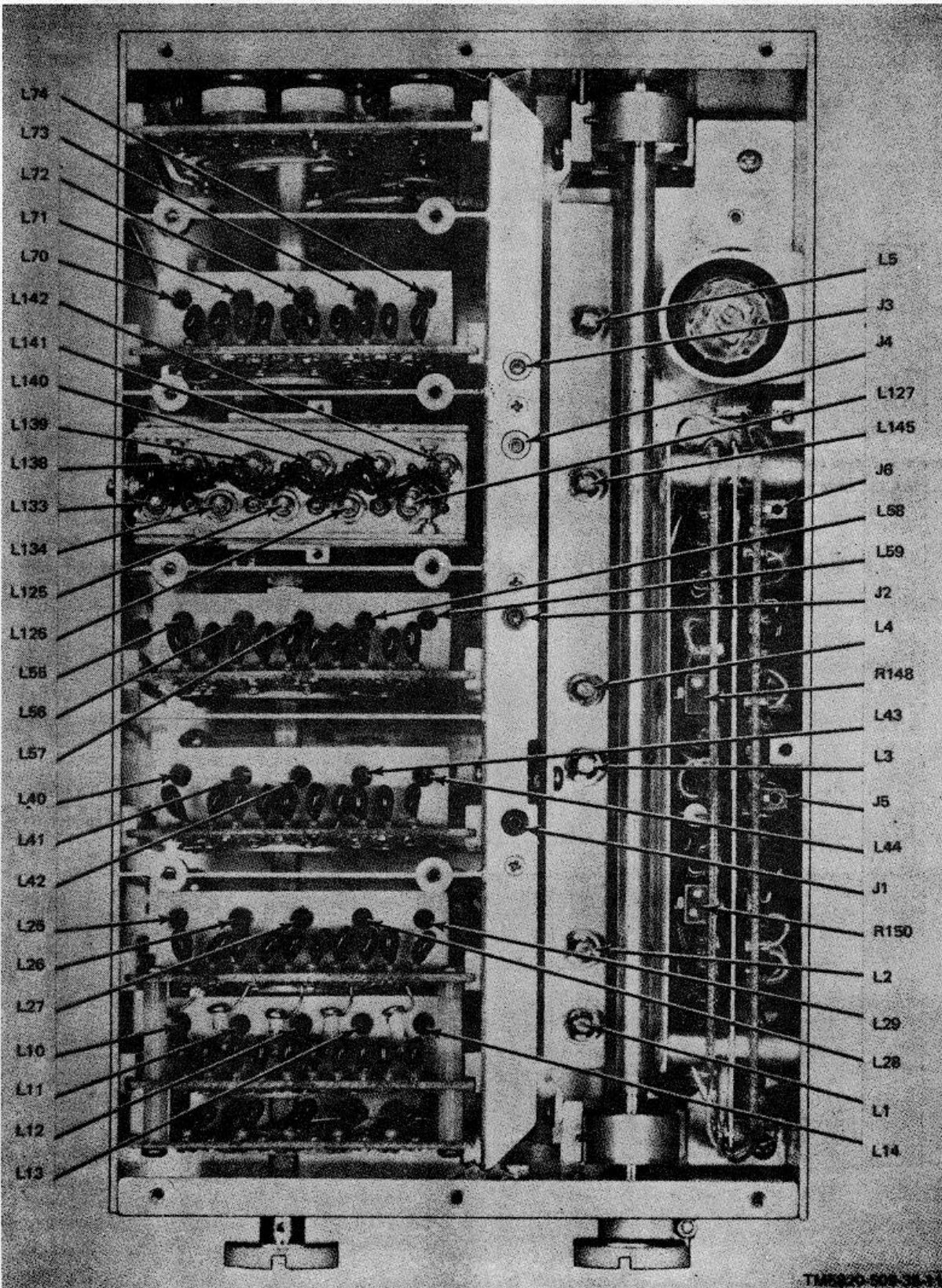

Figure 3-96. Signal Data Translator CV-1377A-PRC-47(A8A3), Top View, Location of Test Points and Adjustments.

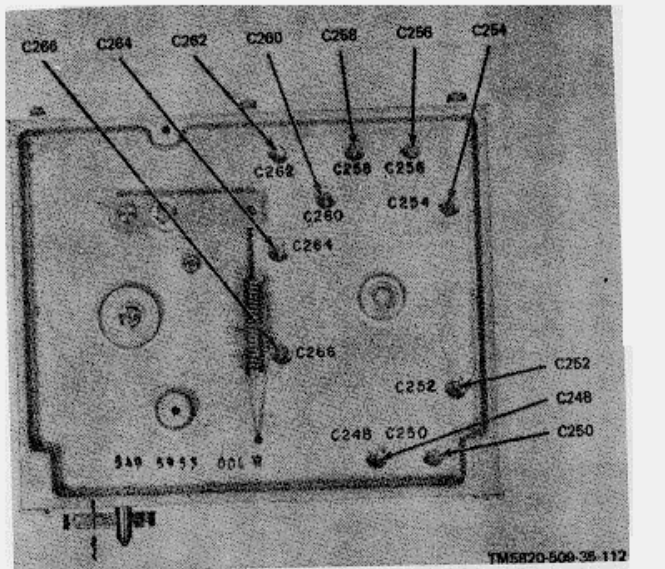

Figure 3-97. Signal Data Translator CV-1377A/PRC-47 (A8A3), Rear View, Location of Adjustments.

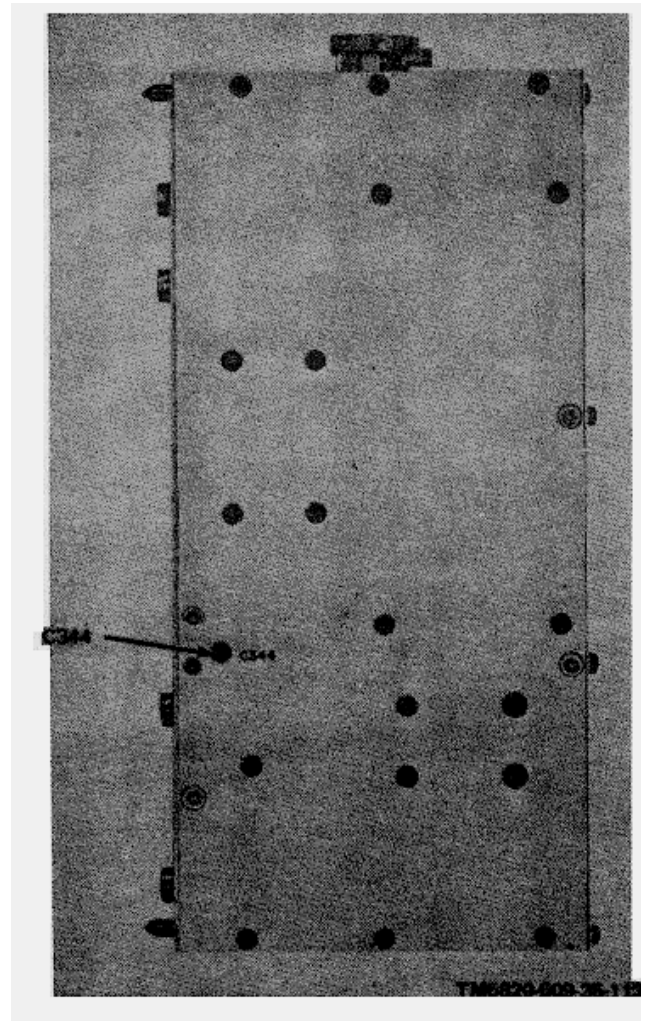

Figure 3-98. Signal Data Translator CV-1377A/PRC-47 (A8A3), Right Side View, Location of Adjustment C344.

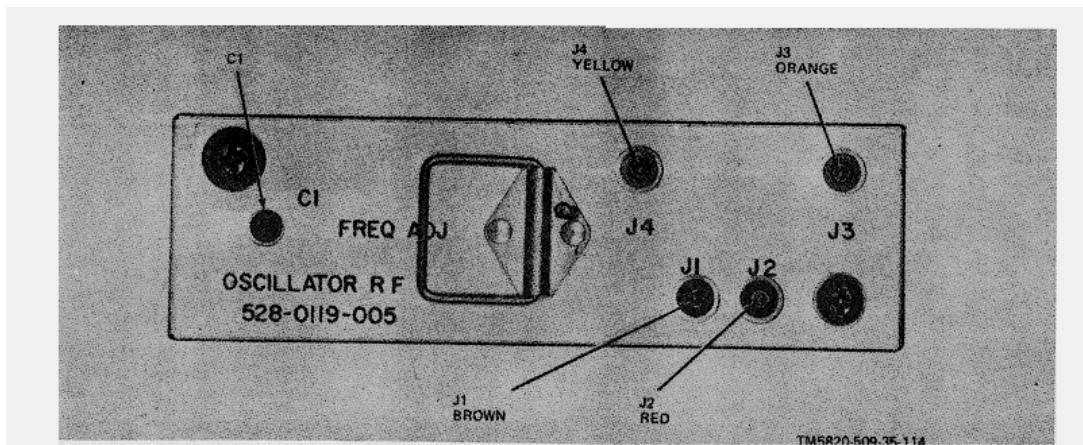

Figure 3-99. Radio Frequency Oscillator O-1032/PRC-47 (A8A6), Top View, Location of Test Points and Adjustments.

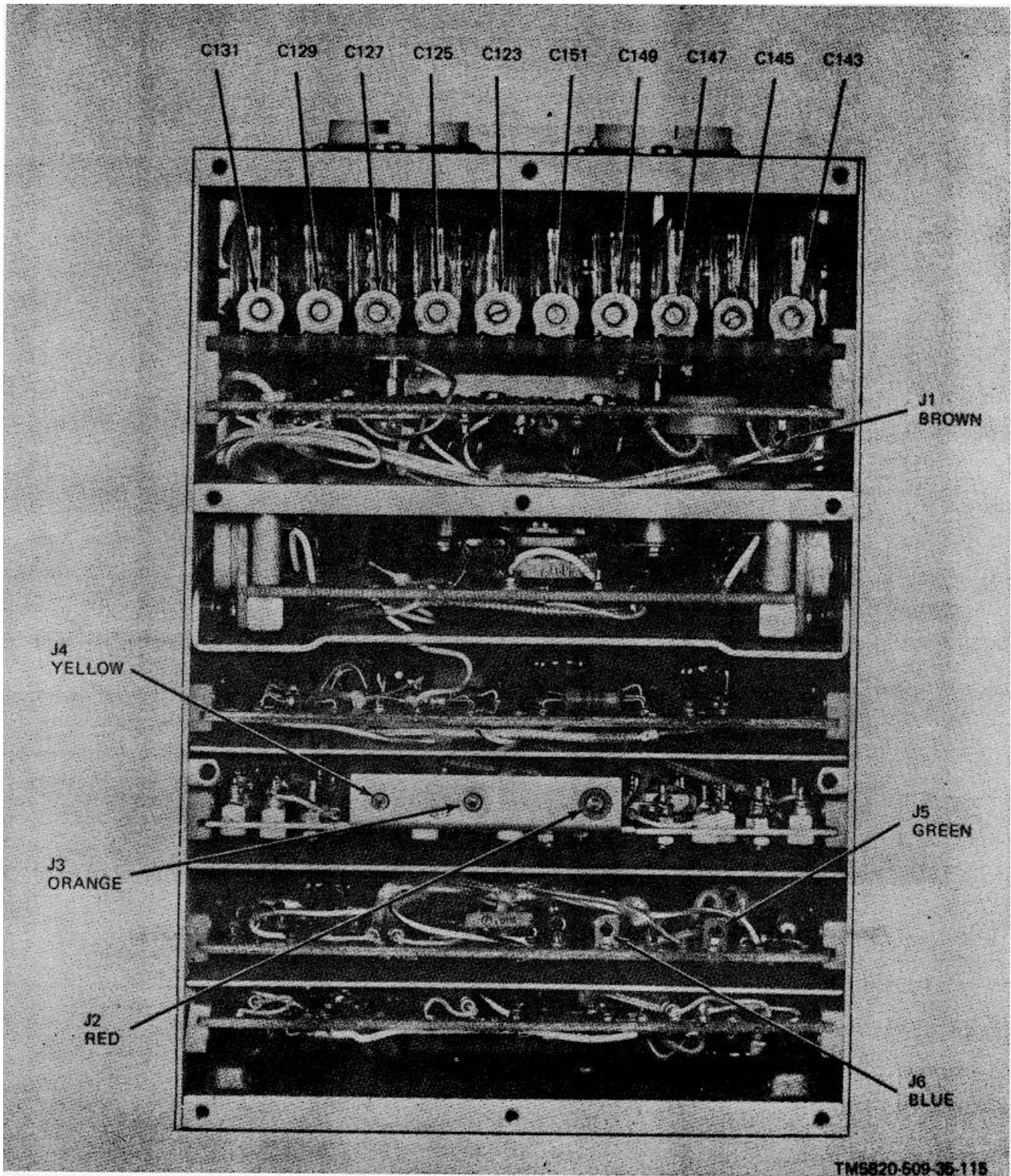

Figure 3-100. Oscillator Control C-4311-PRC-47 (A8A7), Top View, Location of Test Points and Adjustments.

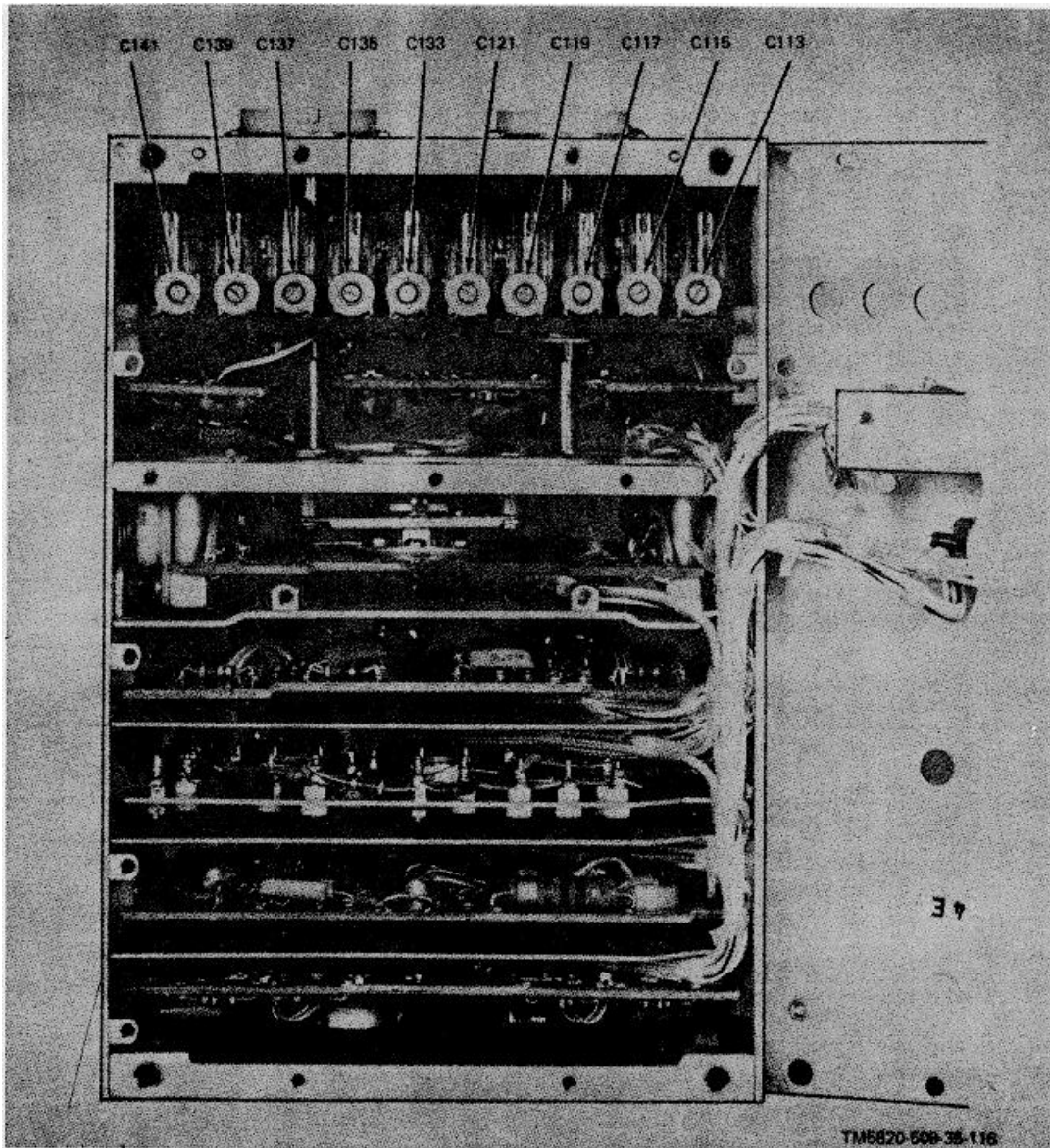

Figure 3-101. Oscillator Control C-4311/PRC-47 (A8A7), Bottom View, Location of Adjustments.

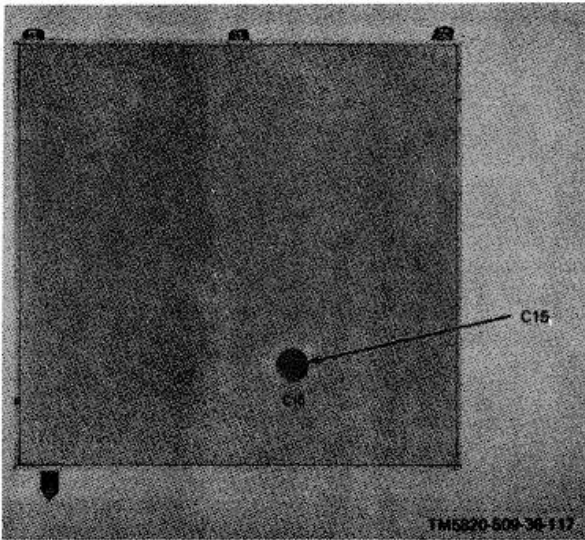

Figure 3-102. Oscillator Control C4311/PRC-47(A8A7), Rear View, Location of Capacitor C15.

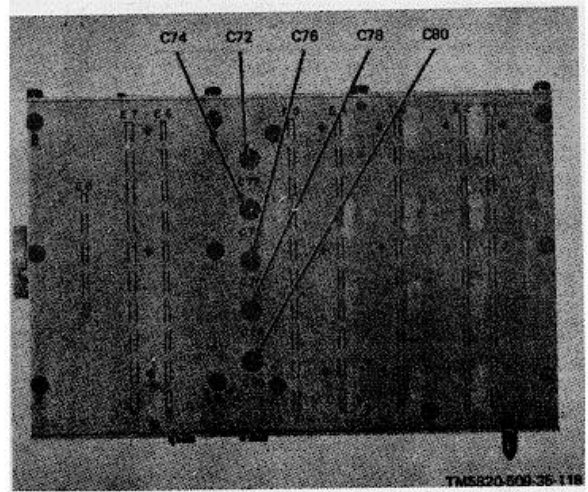

Figure 3-103. Oscillator Control C4311/PRC-47 (A8A7), Right Side, Location of Adjustments.

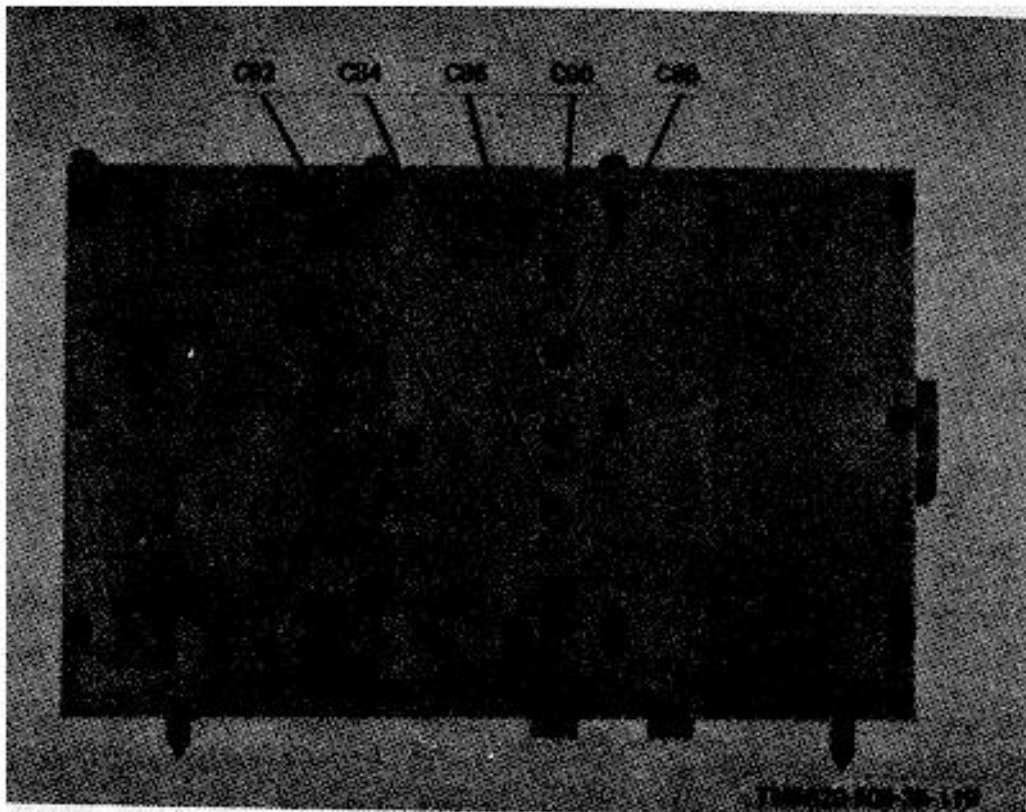

Figure 3-104. Oscillator Control C-4311/PRC-47 (A8A7), Left Side, Location of Adjustments

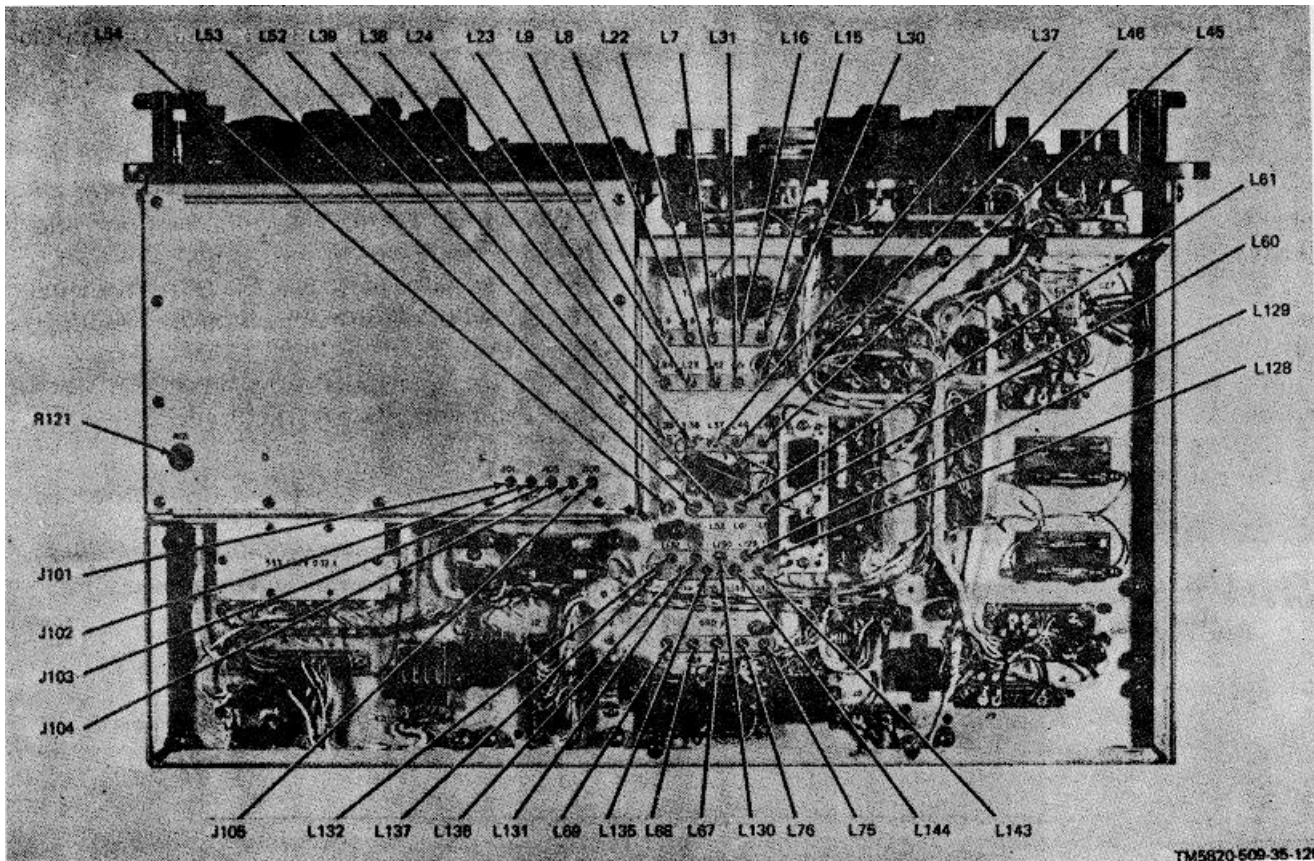

Figure 3-105. Radio Receiver-Transmitter RT-671/PRC-47 ((A8)), Bottom View, Location of Test Points and Adjustments.

3-21. Mechanical Alignment of CV-1377A/PRC-47 STUB Rack Coupler

NOTE

Perform this check only when one or more of the following conditions exist: The RT-671 /PRC-47 frequency selection mechanism has been disassembled for repair; when the CV-1377A/PRC-47 plug-in module has been replaced.

a. *Test Procedures.* Measure the clearance between halves of the slug rack coupler (fig. 3-96) with a feeler gage. Clearance must be 0.002- to 0.020-inches. If not, adjust in accordance with step b.

b. *Adjustment Procedures.*

(1) Remove the RT-671/PRC-47 from its case using the procedures detailed in paragraph 3-11.

(2) Connect the primary power source to the POWER connector on the front panel of RT-671 //PRC-47.

(3) Connect the dc test probe of Multimeter ME-26A/U alternately to test jacks A7J5 and A7J6 of Oscillator Control C-311/PRC 47 (fig. 3-100).

(4) Set the front panel controls of TR-671/PRC-47 as follows:

- (a) POWER-LIGHTS switch to POWER ON.
- (b) KILOCYCLES indicator to 2000.
- (c) CW-FSK/VOICE switch to VOICE.
- (d) OPR-TUNE switch to OPR.

(5) Loosen the setscrew that clamps the shaft collar to the slug rack coupling half and slide the coupling half along the axis of the drive shaft until specification clearance is obtained.

NOTE

Recheck the voltmeter readings during steps (5) and /6) to assure that the slugrack shaft is not rotated during this adjustment.

- (6) Retighten the shaft collar setscrew tightly.
- (7) Place POWER-LIGHTS switch to POWER OFF and disconnect the multimeter.
- (8) Return the RT 671/PRC-47 to its case using the procedures of paragraph 3-11 if no further adjustments are required.

3-22. Receiver Output Adjustments (fig. 3-94, 3-106)

a. Preliminary Procedures.

(1) Remove the RT-671/PRC-47 from its case using the procedures of paragraph 3-11.

(2) Connect the primary power source to the POWER connector on the front panel of RT-671/PRC-47.

(3) Connect the output meter, signal generator and frequency counter to the receiver-transmitter as shown in figure 3-106.

(4) Set the output meter IMPEDANCE switch to 300 ohms, and adjust the meter multiplier for 5000 milliwatts full scale.

(5) Adjust the signal generator to 2226 kHz and set the output level to 1000 microvolts.

(6) On the front panel of RT-671/PRC-47, set the controls as follows:

- (a) KILOCYCLES indicator to 2225.
- (b) CW-FSK/VOICE: switch to VOICE.
- (c) OPR-TUNE switch to OPR.
- (d) VOLUME control to maximum clockwise stop.
- (e) POWER-LIGHTS switch to POWER ON.

b. Adjustment Procedures.

(1) Observe the output meter and adjust A1R54 (fig. 3-94) to obtain a reading of 1000 milliwatts (18 volts in 300 ohms).

(2) Return the POWER-LIGHTS switch to POWER OFF and disconnect the test equipment.

(3) Return the RT-671/PRC-47 to its case using the procedures listed in paragraph 3-11 if no further adjustments are required.

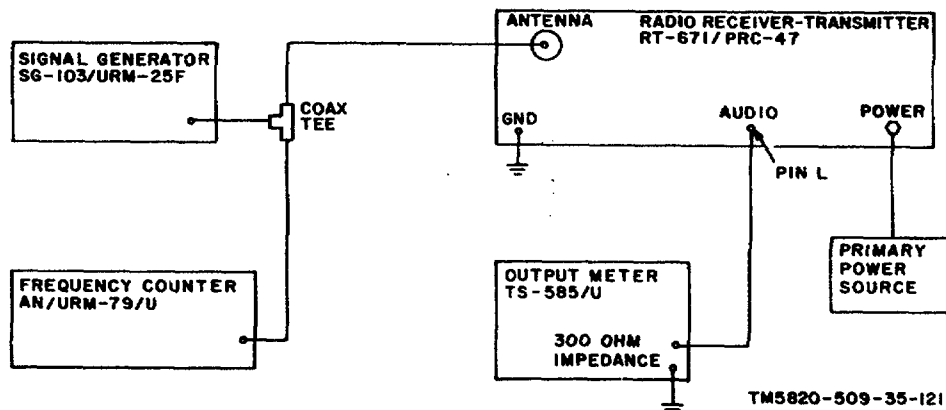

Figure 3-106. Receiver Audio Output Adjustments, Test Equipment Setup.

3-23. Receiver AGC Circuit Adjustments

(fig. 3-94, 3-107)

a. Preliminary Procedures.

(1) Remove the RT-671/PRC-47 from its case using the procedures listed in paragraph 3-11.

(2) Connect the primary power source to the POWER connector on the front panel of RT-671/PRC-47.

(3) Connect the dc probe of Multimeter ME-26A/V to test jack A1J15 (fig. 3-94).

(4) Connect the signal generator and frequency counter to the ANTENNA terminal of the receiver-transmitter as shown in figure 3-107.

(5) Adjust the signal generator to 2226 kHz and set the output level to 1 microvolt.

(6) On the front panel of RT-671/PRC-47, set the controls as follows:

- (a) KILOCYCLES indicator to 2225.
- (b) CW FSK/VOICE switch to VOICE.

- (c) OPR-TUNE switch to OPR.
- (d) POWER-LIGHTS switch to POWER-ON.

b. Adjustment Procedure.

(1) Observe the multimeter and adjust A1R52 (fig. 3-94) until a further counterclockwise adjustment has no effect on the meter reading, but a clockwise adjustment increases the meter reading.

(2) If step b (1) is unsuccessful, adjust A1R52 to its clockwise stop and then vary the output of the signal generator between 0.1 and 1.6 microvolts. The agc threshold must occur between 0.6 and 1.2 microvolts.

(3) Return POWER-LIGHTS switch to POWER OFF and disconnect the test equipment.

(4) Return the RT-671/PRC-47 to its case using the procedures of paragraph 3-11 if no further adjustments are required.

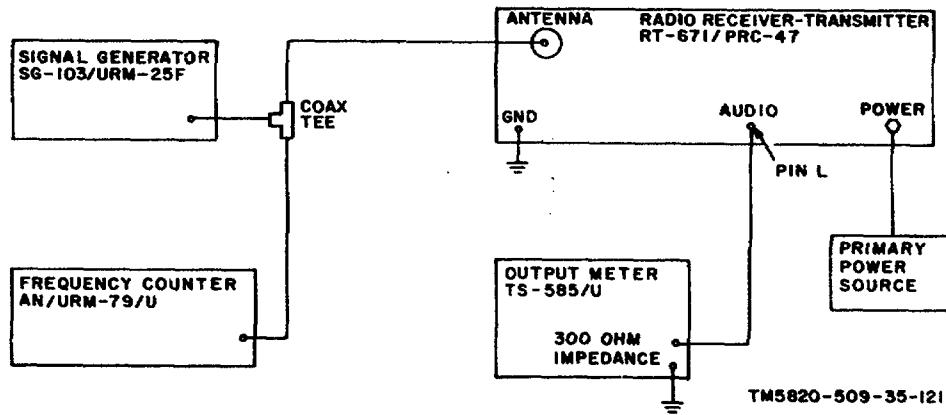

Figure 3-107. Receiver AGC Circuit Adjustment, Test Equipment Setup.

3-24. Transmitter Sidetone Adjustment

(fig. 3-94, 3-108)

a. Preliminary Procedures.

(1) Remove the RT-671/PRC-47 from its case using the procedures of paragraph 3-11.

(2) Connect the primary power source to the POWER connector on the front panel of RT-671 /PRC-47.

(3) Connect the output meter and dummy load to the receiver-transmitter as shown in figure 3-108.

(4) Set the output meter IMPEDANCE switch to 300 ohms, and adjust the meter multiplier for 500 milliwatts full scale.

(5) On the front panel of RT-671/PRC-47, set the controls as follows:

- (a) KILOCYCLES indicator to 2000.
- (b) CW-FSK/VOICE switch to VOICE.
- (c) OPR-TUNE switch to OPR.
- (d) XMTR PWR switch to LO.
- (e) VOLUME control to maximum clock-wise stop.
- (f) POWER-LIGHTS switch to POWER ON.

CAUTION

Do not permit the OPR-TUNE switch to remain in the TUNE position for more than a few seconds at a time while the POWER AMPLIFIER TUNE and POWER AMPLIFIER LOAD

controls are being adjusted. Circuit damage can occur.

(6) Set the POWER AMPLIFIER LOAD and POWER AMPLIFIER TUNE controls to the turns counter values shown on the LOAD-TUNE chart; then place the OPR-TUNE switch to TUNE and quickly peak the load and tune controls for maximum deflection of the XMTR OUTPUT meter.

NOTE

Adjust M ADJ control as required to maintain the XMTR OUTPUT meter pointer on a useful portion of the scale.

(7) Return the OPR-TUNE switch to OPR and set XMTR PWR switch to HI.

(8) Again place the OPR-TUNE switch to TUNE and peak the POWER AMPLIFIER LOAD and POWER AMPLIFIER TUNE controls as necessary for maximum XMTR OUTPUT meter deflection.

b. Adjustment Procedures.

(1) Observe the output meter and adjust A1R46 (fig. 3-94) to obtain a reading of 100 milliwatts (5.5 volts in 300 ohms).

(2) Return the XMTR PWR switch to OFF, the POWER-LIGHTS switch to POWER OFF, and disconnect the test equipment.

(3) Return the RT-671/PRC-47 to its case using the procedures of paragraph 3-11 if no further adjustments are required.

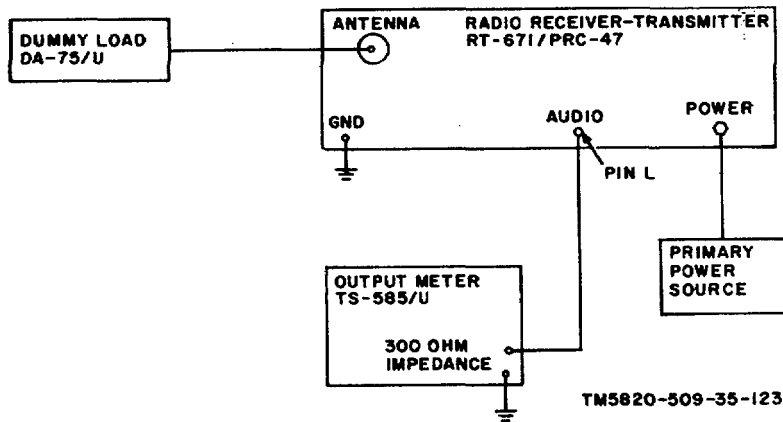

Figure 3-108. Transmitter Sidetone Adjustment, Test Equipment Setup.

3-25. Microphone Amplifier Gain Adjustment

(fig. 3-94, 3-105, 3-109)

a. Preliminary Procedures.

(1) Remove the RT-671/PRC-47 from its case using the procedures of paragraph 3-11.

(2) Connect the primary power source to the POWER connector on the front panel of RT- 671 /PRC - 47.

(3) Connect the audio oscillator, oscilloscope, multimeter, and blocking capacitor to the receiver-transmitter as shown in figure 3-109.

(4) Set the audio oscillator to 1700 Hz and adjust the output level at pin C of the AUDIO connector to 0.1 volt rms.

(5) On the front panel of RT-671/PRC-47, set the controls as follows:

- (a) KILOCYCLES indicator to any

- (b) CW-FSK/VOICE switch to CW.
- (c) OPR-TUNE switch to OPR.
- (d) XMTR PWR switch to OFF.
- (e) POWER-LIGHTS switch to POWER

ON.

b. Adjustment Procedures.

(1) Connect the oscilloscope to chassis connector J2-22 (fig. 3-105) and adjust A1R27 (fig. 3-94) to obtain an oscilloscope amplitude of 3.5 volts peak-to-peak.

(2) Return the POWER-LIGHTS switch to POWER OFF and disconnect the test equipment.

(3) Return the RT-671 /PRC-47 to its case using the procedures of paragraph 3-11 if no further adjustments are required.

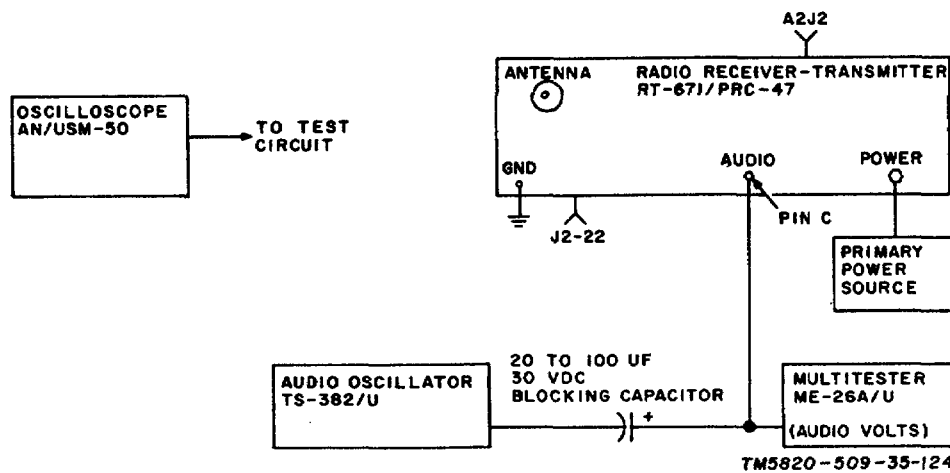

Figure 3-109. Microphone Amplifier and VOX Gain Adjustments, Test Equipment Setup.

3-26. Transmitter VOX Gain Adjustment

(fig. 3-94, 3-95)

NOTE

Perform this adjustment routine only on Radio Set AN /PRO-47 that has

been internally connected for VOX operation (para 2-1b).

a. *Preliminary Procedures.*

(1) Perform the microphone amplifier gain adjustment procedures detailed in paragraph 3-25 a (1) through 3-25 b (1).

(2) Reduce the audio oscillator output to 0.01 + 0.002 volts rms as indicated on the multimeter.

b. *Adjustment Procedures.*

(1) Connect the oscilloscope to test jack A2J2 (fig. 3 95).

(2) Adjust A1R40 (fig. 3-94) until a 500-kHz signal appears on the oscilloscope trace. (this indicates the operation of vox relay A1K1.)

(3) Return the POWER-LIGHTS switch to POWER OFF and disconnect the test equipment.

(4) Return the RT-671/PRC-47 to its case using the procedures of paragraph 3-11 if no further adjustments are required.

3-27. Power Amplifier Grid Drive Alignment and Bias Adjustments

(fig. 3-96, 3-105, 3-110)

NOTE

Perform this alignment routine only after it has been determined that an equipment malfunction is caused by improper alignment (tracking) of Signal Data Translator CV-1377A/PRC-47 (A8A3).

a. *Preliminary Procedures.*

(1) Remove the RT-671/PRC-47 from its case using the procedures of paragraph 3-11.

(2) Connect the primary power source to the POWER connector of RT-671/PRC-47.

(3) Connect the rf probe of the multimeter to test jack J104 (fig. 3-105) of the power amplifier.

(4) Connect the antenna simulator of AN/PRA-4 and the dummy load to the receiver-transmitter as shown in figure 3-110. Set the selector switch on the antenna simulator to the 2.0 MHz position.

(5) On the front panel of RT-671/PRC-47, set the controls as follows:

- (a) KILOCYCLES indicator to 2000
- (b) CW-FSK/VOICE switch to VOICE.
- (c) OPR-TUNE switch to OPR.
- (d) XMTR PWR switch to LO.
- (e) POWER-LIGHTS switch to POWER

ON.

CAUTION

Do not permit the OPR-TUNE switch to remain in the TUNE position for more than a few seconds at a time while the POWER AMPLIFIER LOAD

and the POWER AMPLIFIER TUNE controls are being adjusted. Circuit damage can occur.

(6) Set the POWER AMPLIFIER LOAD and POWER AMPLIFIER TUNE controls to the turns-counter values indicated on the LOAD-TUNE chart; then place the OPR-TUNE switch to TUNE and quickly peak the load and tune controls for maximum deflection of the pointer on the XMTR OUTPUT meter.

NOTE

Adjust M ADJ control as required to maintain the XMTR OUTPUT meter pointer on the useful portion of the meter scale.

(7) Return the OPR-TUNE switch to OPR and set the XMTR PWR switch to HI.

(8) Again place the OPR-TUNE switch to TUNE and peak the POWER AMPLIFIER LOAD and POWER AMPLIFIER TUNE controls as necessary for maximum XMTR OUTPUT meter deflection.

b. *Alignment Procedures.*

(1) Adjust A3L67 (fig. 3-105) for maximum rf grid drive as indicated on the multimeter connected to test point J104.

(2) On the front panel of RT-671/PRC-47, place the OPR-TUNE switch to OPR, set the KILOCYCLES indicator to 3000, and place the XMTR PWR switch to LO. On the antenna simulator rotate the selector switch to 3.0 MHz position; then repeat steps (6) through (8) of the preliminary procedures above.

(3) Adjust A3L68 (fig. 3-105) for maximum rf grid drive as indicated by the multimeter connected to test point J104.

(4) Repeat step b (2) except set KILOCYCLES indicator to 4000 and set the rotary switch on the antenna simulator to the 4.0 MHz position.

(5) Adjust A3L69 (fig. 3-105) for maximum rf grid drive as indicated by the multimeter connected to test point J104.

(6) Repeat step b (2) except set KILOCYCLES indicator to 5000 and set the rotary switch on the antenna simulator to the 5.0 M H z position.

(7) Adjust A3L70 (fig. 3-96) for maximum rf grid drive as indicated by the multimeter connected to test point J104.

(8) Repeat step b (2) except set KILOCYCLES indicator to 6000 and set the rotary switch on the antenna simulator to the 6.0 MHz position.

(9) Adjust A3L71 (fig. 3-96) for maximum rf grid drive as indicated by the multimeter connected to test pint J104.

(10) Repeat step b (2) except set

KILOCYCLES indicator to 7000 and set the rotary switch on the antenna simulator to the 7.0 MHz position.

(11) Adjust A3L72 (fig. 3-96) for maximum rf grid drive as indicated by the multimeter connected to test point J104.

(12) Repeat step b (2) except set KILOCYCLES indicator to 8000 and set the rotary switch on the antenna simulator to the 8.0 MHz position.

(13) Adjust A3L73 (fig. 3-96) for maximum rf grid drive as indicated by the multimeter connected to test point J104.

(14) Repeat step b (2) except set KILOCYCLES indicator to 9000 and set the rotary switch on the antenna simulator to the 9.0 MHz position.

(15) Adjust A3L74 (fig. 3-96) for maximum rf grid drive as indicated by the multimeter connected to test point J104.

(16) Repeat step b (2) except set KILOCYCLES indicator to 10000 and set the rotary switch on the antenna simulator to the 10.0 MHz position.

(17) Adjust A3L76 (fig. 3-105) for maximum rf grid drive as indicated by the multimeter connected to test point J104.

(18) Repeat step b (2) except set KILOCYCLES indicator to 11000 and set the rotary

switch on the antenna simulator to the 11.0 MHz position.

(19) Adjust A3L76 (fig. 3-105) for maximum rf grid drive as indicated by the multimeter connected to test point J104.

c. Power Amplifier Bias Adjustments.

NOTE

Perform these adjustments only after completing the alignment procedures of step b above.

(1) Connect the dc probe of the multimeter to the following test jacks on Power Supply PP. 3518/PRC-47 (A8A5).

(a) At ABJ1 the correct reading is -32 ±1 volt; if not, adjust A5R4 as required.

(b) At A5J2 the correct reading is -110 ±13.3 volts; if not, adjust A5R3 as required.

(c) At A5J8 the correct reading is +19 ±0.6 volts; if not, adjust A5R22 as required.

(2) Return the XMTR PWR switch to OFF, the POWER-LIGHTS switch to POWER OFF, disconnect the test equipment, and return the RT-671/PRC-47 to its case using the procedures of paragraph 3-11 if no further adjustments are required.

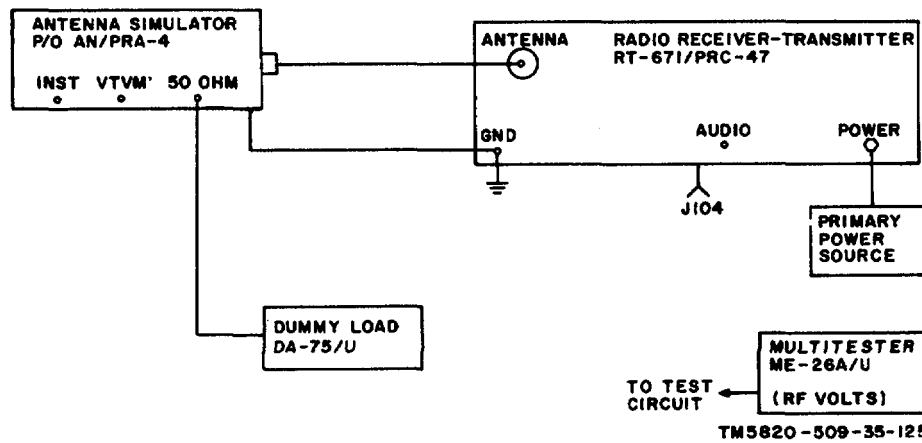

Figure 3-110. Power Amplifier Grid Drive Adjustment, Test Equipment Setup.

3-28. Temperature Compensated Oscillator Frequency Adjustment (fig. 3-111)

NOTE

Perform this adjustment only if Radio Frequency Oscillator 0-1032/PRC-47 (A8A6) has been repaired or replaced, or if this module is suspected of generating an incorrect output frequency.

a. Preliminary Procedures.

(1) Remove the RT-671/PRC-47 from its case using the procedures of paragraph 3-11.

(2) Connect the primary power source to the POWER connector of RT-671/PRC-47.

(3) Connect the frequency counter to test jack A6J4 (fig. 3-99) of Radio Frequency Oscillator 0-1032/PRC-47.

(4) On the front panel of RT-671/PRC-47, set the controls as follows:

- (a) KILOCYCLES indicator to 2000.
- (b) CW-FSK/VOICE switch to VOICE.
- (c) OPR-TUNE switch to OPR.
- (d) XMTR PWR switch to OFF.
- (e) POWER-LIGHTS switch to POWER

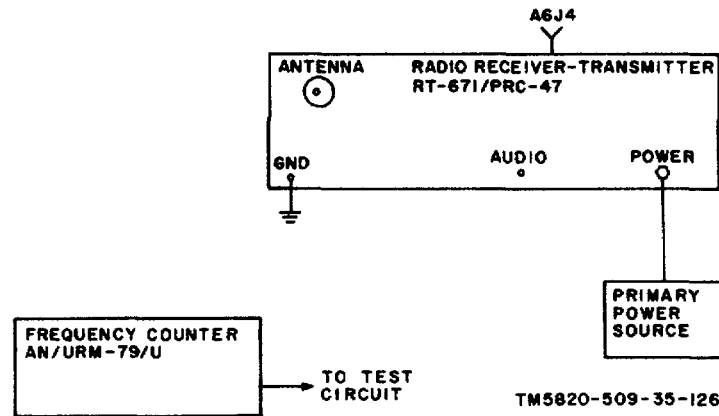

Figure 3-111. Temperature Compensated Oscillator Rotor Frequency Adjustment Test Equipment Setup.

b. Alignment Procedures.

(1) Measure the output frequency using the frequency counter connected to A6J4.

(2) If the output frequency does not read exactly 5000,000.0 Hz, adjust A6C1 (fig. 3-99) ON.

until the frequency counter reads correctly.

(3) Return the POWER-LIGHTS switch to POWER OFF and disconnect the test equipment.

(4) Return the RT-671/PRC-47 to its case using the procedures of paragraph 3-11 if no further adjustments are required.

3-29. Balanced Modulator Adjustments

(fig. 3-112)

a. Preliminary Procedures.

(1) Remove the RT-671/PRC-47 from its case using the procedures listed in paragraph 3-11.

(2) Connect the primary power source to the POWER connector on the front panel of RT 671 /PRC-47.

(3) Connect the dummy load to the receiver transmitter; extend Amplifier-Modulator AM 3507/PRC-47 (A8A2) from the main chassis of RT 671/PRC-47 using extender cable no. 4 from Cable Assembly Set AN /PRA-4; then remove the module side cover to expose the adjustment screw in the top of transformer T2.

(4) Set the front panel controls of RT-671/PRC-47 as follows:

- (a) KILOCYCLES indicator to 2000.
- (b) CW-FSK/VOICE switch to VOICE.
- (c) OPR-TUNE switch to OPR.
- (d) XMTR PWR switch to LO.
- (e) POWER-LIGHTS switch to POWER

CAUTION

Do not permit the OPR-TUNE switch to remain in the TUNE position for more than a few seconds at a time while the POWER AMPLIFIER TUNE and POWER AMPLIFIER LOAD controls are being adjusted. Circuit damage can occur.

(5) Set the POWER AMPLIFIER TUNE and POWER AMPLIFIER LOAD controls to the turns-counter values shown on the LOAD-TUNE chart.

(6) Place the OPR-TUNE switch to TUNE; quickly peak the POWER AMPLIFIER TUNE and POWER AMPLIFIER LOAD controls for maximum deflection on the XMTR OUTPUT meter. Immediately return the PPR-TUNE switch to OPR.

NOTE

Adjust M ADJ control as required to maintain the XMTR OUTPUT meter pointer on a useful portion of the scale.

(7) Place the XMTR PWR switch to HI and repeat step (6).

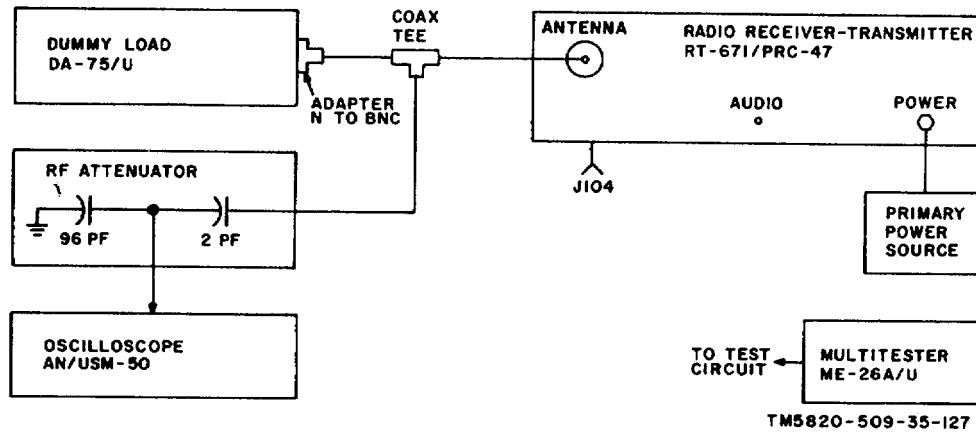

Figure 3-112. Balanced Modulator Adjustments, Test Equipment Setup

b. Adjustment Procedures.

- (1) Connect the rf probe of the multimeter to J104 (fig. 3-105).
- (2) Place the OPR-TUNE switch to TUNE and adjust the slug on the top of transformer A2T2 (fig. 3-20) for maximum indication on the multimeter.
- (3) Return the OPR-TUNE switch to OPR; place the CW-FSK/VOICE switch to CW-FSK.

- (4) Observe the transmitter carrier output on the oscilloscope and adjust A2R5 and A2C35 (fig. 3-95) alternately until the minimum carrier output is obtained.
- (5) Return the POWER-LIGHTS switch to POWER OFF and disconnect the test equipment.
- (6) Return the RT-671/PRC-47 to its case using the procedures of paragraph 3-11 if no further adjustments are required.

**CHAPTER 4
GENERAL SUPPORT MAINTENANCE**

4-1. General

a. The tests presented in this chapter verify the proper operation of Radio Set AN/PRC-47 after repair procedures have been completed.

b. The instructions that precede each performance chart establish the test conditions and present specific information for a given test. Perform each test in the sequence shown being careful to complete all actions required by the procedure. The test results must agree

with each respective performance standard to assure proper operation of the radio set.

4-2. Test Equipment Required

All test equipment and materials required to perform the procedures shown in this chapter are listed in the following chart. No special tools or materials are required for these tests.

<i>Test equipment</i>	<i>FSN</i>	<i>Technical manual</i>
Multimeter ME-26A/U	6625-542-6407	TM 11-6625-200-15
Oscilloscope AN/USM-50		TM 11 -5 129
Signal Generator SG-103/URM-25F		
Frequency Counter AN/URM-79/U		
Audio Oscillator TS-382/U	6625-246-8729	TM 11-6625-935-12
Dummy Load DA-75/U		
Cable Assembly Set AN/PRA-4	5995-973-3686	
Output Meter TS-585/U		TM 11 -5017
Radar and Radio Repair Tool Kit TK-87/U		
Radar and Radio Repair Supplementary Tool Kit TK-88/U		
Spectrum Analyzer TS-723A/U	6625-668-9418	TM 11 -5097

4-3. Test Facilities

A primary power source of 115 volts, 400 Hz, single-phase alternating current at approximately 3.0 amperes, and a 26.5-volt direct current source at approximately 11 amperes is required for these tests.

4-4. Modification Work Orders

The performance standards listed in the tests (pare 4-5 through 4-19) assume that all applicable modification work orders have been performed.

4-5. Physical Tests and Inspection

Perform each of the following steps to assure compliance with the maintenance standard.

NOTE

Remove Radio Receiver-Transmitter RT-671/PRC 47 from its case using the procedures detailed in paragraph 3-11.

Step	Test equipment settings	Radio control settings	Test procedures	Performance standards
1	n/a	n/a	a. Inspect all gears and mechanical assemblies for loose or missing hardware. b. Inspect all connectors, sockets, receptacles, fuse holders, and lamp sockets for looseness or damage.	a. Screws, setscrew, bolts, and nuts must be tight, no missing parts. b. All items secured tightly to panel with no evidence of damage.
2	n/a	n/a	a. Rotate whole megahertz frequency control knob one step at a time from 2000 to 11000 on KILOCYCLES indicator.	a. Bandswitch gears in signal data translator (A3), oscillator control (A7), and in Bandswitch assembly, rotate freely one step at a time as knob is turned.
3	n/a	n/a	b. Rotate 100-kHz frequency control knob one step at a time from X000 to X900 on KILOCYCLES indicator. a. Inspect case and chassis for damage, missing parts, the condition of the finish, and panel lettering. Modules must be removed to complete this inspection.	b. Slug rack in signal data translator (A3) withdraws smoothly as knob advances one step at a time. a. No damage or missing parts visible; external surfaces originally painted show no bare metal. Panel lettering legible.

NOTE

Paint should be touched up in lieu of refinishing whenever practical. Screw heads, binding posts, receptacles, and plated parts are not painted and must not be polished with abrasives.

			b. Inspect all wiring in the area of repairs for cracks, chips, or other breaks in the moisture-proofing varnish.	b. All repaired or disturbed electrical wiring and components are secured and moisture-proofed.
--	--	--	---	---

4-6. Receiver Sensitivity Tests

(fig. 4-1)

NOTE

This test must be performed in a screen-room similar to Electro-Magnetic Shielding Enclosure MX-1766/G or equal.

a. Test Equipment and Material.

- (1) Signal Generator SG-103/URM-25F.
- (2) Frequency Counter AN/URM-79/U.
- (3) Spectrum Analyzer TS-723A/U.
- (4) Audio load, 300-ohm, 1-watt composition resistor.
- (5) Coaxial tee, UG-274B/U.

(6) Primary power source: 115-volt, 400-Hz, single-phase, 3 amps. 26.5-volt, dc, 11 amperes approx.

b. Test Conditions and Equipment Connections.

(1) Connect the test equipment to Radio Receiver-Transmitter RT-671/PRC-47 as shown in figure 4-1.

(2) Connect the 115-volt primary power source to the receiver-transmitter.

(3) Turn on the test equipment and place the POWER-LIGHTS switch of RT-671/PRC-47 to POWER ON. Permit the equipment to stabilize for at least 6 minutes before beginning the procedures shown in the chart below.

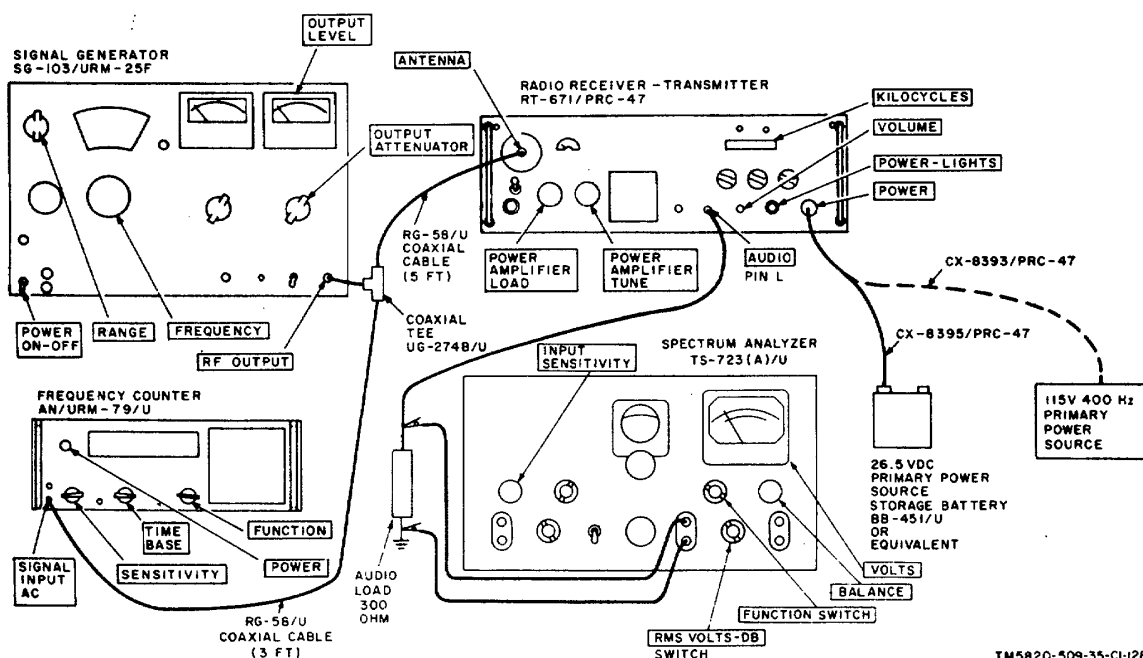

Figure 4-1. Receiver Sensitivity, AVC Selectivity, IF. Rejection, Image Rejection, and Volume Control Tests, Equipment Setup.

c. Procedure After each adjustment of the frequency control knobs on the front panel of the receiver-transmitter, readjust the signal generator

output frequency to the newly selected transmitter operating frequency, plus 1 kHz, and reset the output level to the required value.

Step	Test equipment settings	Radio control settings	Test procedures	Performance standards
1	Adjust signal generator to 2226 kHz; kHz; set output level to 20 microvolts.	Adjust frequency control knobs to 2225 on KILOCYCLES indicator CW-FSK/VOICE to VOICE; OPR-TUNE to To maximum clockwise stop.	<ol style="list-style-type: none"> a. Read audio output voltage across 300-ohm audio load. b. Disconnect signal generator from ANTENNA terminal Across 300-ohm audio load. 	<ol style="list-style-type: none"> a. Minimum acceptable voltage of 1.9 volts rms. of 3.9 volts rms b. Maximum acceptable voltage 1.25 volts rms. 1.25 volts rms.

Step	Test equipment settings	Radio control settings	Test procedures	Performance standards
2	Same as step 1 at each of the following frequencies: 3226, 3776, 4226, 4776, 5226, 5776, 6226, 6776, 7226, 8226, 8776, 9226, 9776, 10226, 10776, 11226. 11776 kHz; maintain 2.0 microvolts output.	Same as step 1 at the following KILOCYCLES indicator readings: 3225, 3775, 4225, 4775, 5225, 5775, 6225, 6775, 7225, 7775, 8225, 8775, 9225, 9775, 10225, 10775, 11225, and 1175.	<p>a. Repeat procedure of step 1a at each operating frequency.</p> <p>b. Repeat procedure of step 1b at each operating frequency.</p>	<p>a. Same as step 1a at each operating frequency.</p> <p>b. Same as step 1b at each operating frequency.</p>
3	Same as step 1.	Same as step 1 except use 26.5 volt dc primary power source.	<p>a. Repeat procedure of step 1a using 26.5-volt dc primary power source.</p> <p>b. Repeat procedure of step 1b using 26.5-volt dc primary power source.</p>	<p>a. Same as step 1a.</p> <p>b. Same as step 1b</p>
4.	Same as step 2.	Same as step 2 except use 26.5 volt dc primary power source.	<p>a. Repeat procedure of step 1a at each operating frequency using 26.5-volt dc primary power source.</p> <p>b. Repeat procedure of step 1b at each operating frequency using 26.5-volt dc primary power source.</p>	<p>a. Same as step 1a at each operating frequency.</p> <p>b. Same as step 1b at each operating frequency.</p>

4-7. Receiver AVC Characteristic Test

(fig; 4-1)

a. Test Equipment and Material.

- (1) Signal Generator SG-103/URM-25F
- (2) Frequency Counter AN/URM-79/U
- (3) Spectrum Analyzer TS 723A/U.
- (4) Audio load, 300-ohm, 1-watt composition resistor.

(5) Primary power source: 115-volt, 400 Hz, single-phase, 3 amps. 26.5-volt, dc, 11 amperes approx.

b. Test Conditions and Equipment Connections.

(1) Connect the test equipment to Radio Receiver-Transmitter RT-671/PRC47 as shown in figure 4-1.

(2) Connect the primary power source to the receiver-transmitter.

(3) Turn on the test equipment and place the POWER-LIGHTS switch of RT-671/PRC 47 to POWER ON. Permit the equipment to stabilize for at least 5 minutes before beginning the procedures shown in the chart below.

c. Procedure. After each adjustment of the frequency control knobs on the front panel of the receiver-transmitter, readjust the signal generator output frequency to the newly selected transmitter operating frequency plus 1kHz, and reset the output level to the required value.

Step	Test equipment settings	Radio control settings	Test procedures	Performance standards
1	Adjust signal generator to 2226 kHz; set output level to 5.0 microvolts.	Adjust frequency control knobs to 2225 on KILOCYCLES indicator; CW-FSK/VOICE to VOICE; OPR-TUNE to OPR; VOLUME control to maximum clockwise stop.	Read audio output voltage across 300-ohm audio load.	Record output voltage for reference below.
2	Increase signal generator output to 0.1 volts.	Same as step 1.	Read audio output voltage across 300-ohm audio load.	Reading in this step must not exceed 3.16 times the reading in step 1.
3	Same as step 1 except set output to 4226 kHz.	Same as step 1 except set frequency control knobs for 4225 on KILOCYCLES indicator.	Repeat procedures of step 1 at 4225 kHz.	Record output voltage for reference below.
4	Same as step 2.	Same as step 3.	Read audio output voltage across 300 ohm audio load.	Reading in this step must not exceed 3.16 times the reading in step 3.
5	Same as step 1 except set output at 6226 kHz.	Same as step 1 except set frequency control knobs for 6225 on KILOCYCLES in-	Repeat procedure of step 1 at 6225 kHz.	Record output voltage for reference below.

Step	Test equipment settings	Radio control settings	Test procedures	Performance standards
6	Same as step 2.	Same as step 5.	Read audio output voltage across 300-ohm audio load.	Reading in this step must not exceed 3.16 times the reading in step 5.
7	Same as step 1 except set output to 8226 kHz.	Same as step 1 except set frequency control knobs for 8225 on KILOCYCLES indicator.	Repeat procedure of step 1 at 8225 kHz.	Record output voltage for reference below.
8	Same as step 2.	Same as step 7.	Read audio output voltage across 300-ohm audio load.	Reading in this step must not exceed 3.16 times the reading in step 7.
9	Same as step 1 except set output to 10226 kHz.	Same as step 1 except set frequency control knobs to 10225 on KILOCYCLES indicator.	Repeat procedure of step 1 at 10225 kHz.	Record output voltage for reference below.
10	Same as step 2.	Same as step 9.	Read audio output voltage across 300-ohm audio load.	Reading in this step must not exceed 3.16 times the reading in step 9

4-8. Receiver Selectivity Tests

(fig. 4-1)

a. Test Equipment and Material

- (1) Signal Generator SG-103/URM-25F
- (2) Frequency Counter AN/URM-79/U.
- (3) Spectrum Analyzer TS-723A/U.
- (4) Audio load, 300-ohm, 1-watt composition

resistor.

(5) Primary power source: 115-volt, 400-Hz, single-phase, 3 amps. 26.5-volt, dc, 11 amperes approx.

b. Test Conditions and Equipment Connections.

(1) Connect the test equipment to Radio Receiver-Transmitter RT-671/PRC-47 as shown in figure 4-1.

(2) Connect the primary power source to the receiver-transmitter.

(3) Turn on the test equipment and place the POWER-LIGHTS switch of RT-671/PRC-47 to POWER ON. Permit the equipment to stabilize for at least 5 minutes before beginning the procedures shown in the chart below.

c. Procedure.

Step	Test equipment settings	Radio control settings	Test procedures	Performance standards
1	Adjust signal generator to 2226.7k 2226.7 kHz; set output level to 2.0 microvolts.	Adjust frequency control knobs to 2225 on KILOCYCLES indicator; CW-FSK/VOICE to VOICE; OPR-TUNE to OPR; VOLUME to maximum clockwise stop.	Read audio output voltage across 300 ohm audio load.	Record output voltage for reference below.
2	Increase output of signal generator to 2,000 microvolts and reduce output frequency until voltage across 300-ohm audio load reads same as step 1.	Same as step 1.	Verify that audio output voltage across 300-ohm audio load is same as in step 1. Record signal generator frequency.	Frequency is not less than 2223.7 kHz.
3	Do not adjust signal generator output level but increase output frequency above 2225 kHz until output across 300-ohm audio load reads same as step 1.	Same as step 1.	Verify that audio output voltage across 300-ohm audio load is same as step 1. Record signal Generator frequency	Frequency is not more than 2229.7 kHz.
4	Same as step 1.	Same as step 1.	Repeat procedure of step 1.	Record output voltage across 300-ohm audio load for reference below.
5	Adjust signal generator output frequency below 2226.7 kHz until the voltage across The 300-ohm audio load is 6db below the value shown In step 4.	Same as step 1.	Verify that audio output voltage across 300-ohm audio load is 6db below reading of step 4. Record signal generator frequency.	Frequency is not more than 2225.300 kHz.

Step	Test equipment settings	Radio control settings	Test procedures	Performance standards
6	Adjust signal generator output frequency above 2226.7 kHz until the voltage across the 300-ohm audio load is 6db below the value shown in step 4.	Same as step 1.	Verify that audio output voltage across 300-ohm audio load is 6db below reading of step 4. Record signal generator frequency	Frequency is not less than 2228.000kHz.

4-9. Receiver If. Rejection Test
(fig. 4-1)

a. Test Equipment and Materials.

- (1) Signal Generator SG-103/URM-25F
- (2) Frequency Counter AN/URM-79/U
- (3) Spectrum Analyzer TM-723A/U.
- (4) load, 300 ohm, 1-watt composition resistor.

(5) Primary power source: 115-volt, 500 Hz, single-phase, 3 amps. 26.5-volt, dc, 11 amperes approx.

b. Test Conditions and Equipment Connections.

(1) Connect the test equipment to Radio Receiver-Transmitter RT-671/PRC-47 as shown in figure 4-1.

(3) Connect the primary power source to the receiver-transmitter.

(3) Turn on the test equipment and place the POWER-LIGHTS switch of RT-671/PRC-47 to POWER ON. Permit the equipment to stabilize for at least 5 minutes before beginning the procedures shown in the chart below.

c. Procedure.

Step	Test equipment settings	Radio control settings	Test procedures	Performance standards
1	Adjust signal generator to 2226 kHz; set output level to 2.0 microvolts.	Adjust frequency control knobs to 2225 on KILOCYCLES indicator; CW-FSK/VOICE to VOICE; OPR-TUNE to OPR; VOLUME control to maximum clockwise.	Read audio output voltage across 300-ohm audio load.	Record output voltage for reference below.
2	Adjust signal generator to 499 kHz; increase output level to obtain same output voltage across 300-ohm audio load As in step 1.	Same as step 1.	Verify that audio output voltage across 300-ohm audio load is same as step 1. Record signal generator output level.	Level not less than 20,000 microvolts.
3	Adjust signal generator to 11776 kHz; set output level to 2. Microvolts.	Same as step 1 except set frequency control knobs for 11775 on KILOCYCLES indicator.	Read audio output voltage	Record output voltage for
4	Same as step 2.	Same as step 3.	Verify that audio output voltage across 300-ohm audio load is same as step 3. Record signal generator output level.	Level not less than 20,000 microvolts.

Change 2 4-5

4-10. Receiver Image Rejection Test

(fig. 4-1)

a. Test Equipment and Material.

- (1) Signal Generator SG-103/URM-25F.
- (2) Frequency Counter AN/URM-79/U.
- (3) Spectrum Analyzer T@723A/U.
- (4) Audio load, 300-ohm, 1-watt composition resistor.

resistor.

(5) Primary power source: 115-volt, 400-Hz, single-phase, at 3 amp. 26.5-volt, dc, 11 amperes approx.

b. Test Conditions and Equipment Connections.

(1) Connect the test equipment to Radio Receiver-Transmitter RT-671/PRC-47 as shown in figure 4-1.

(2) Connect the primary power source to the receiver-transmitter.

(3) Turn on the test equipment and place the POWER-LIGHTS switch of RT-671/PRC 47 to POWER ON. Permit the equipment to stabilize at least 5 minutes before beginning the procedures shown in the chart below.

c. Procedure.

Step	Test equipment settings	Radio control settings	Test procedures	Performance standards
1	<p>a. Adjust signal generator to 2226 kHz; set output level to 5.0 microvolts.</p> <p>b. Adjust signal generator to 3224 kHz, raise output level until voltage across 300-ohm audio load is same as in step 1a.</p>	<p>Adjust frequency control knobs to 2225 on KILOCYCLES indicator; CW-FSK/VOICE to VOICE; OPR-TUNE to OPR; VOLUME control to maximum clock wise.</p>	<p>a. Read audio output voltage across 300-ohm audio load.</p> <p>b. Verify that audio output voltage across 300-ohm audio is same as step 1a Record signal generator output level.</p>	<p>a. Record output voltage for reference below.</p> <p>b. Signal generator output level not less than 50,000 microvolts.</p>
2.	<p>a. Adjust signal generator to 1 1776 kHz; set output level to 5.0 microvolts.</p> <p>b. Adjust signal generator to 12774 kHz; raise output level until voltage across 300-ohm audio load is same as in step 2a</p>	<p>Same as step 1 except set frequency control knobs to 1 1775 on KILOCYCLES indicator.</p>	<p>a. Read audio output voltage across 300-ohm audio load.</p> <p>b. Verify that audio output voltage across 300-ohm audio load is same as step 2a Record signal generator output level</p>	<p>a. Record output voltage for reference below.</p> <p>b. Signal generator output level not less than 1580 microvolts.</p>

4-11. Receiver Volume Control Test

(fig 4-1)

a. Test Equipment and Material.

- (1) Signal Generator SG-103/URM-25F
- (2) Frequency Counter AN/URM-79/U.
- (3) Spectrum Analyzer TS-723A/U.
- (4) Audio load, 300 ohm, 1 watt composition resistor.

(5) Primary power source: 115-volt, 400 Hz, single-phase, 3 amps. 26.5-volt, dc, 11 amperes approx.

b. Test Conditions and Equipment Connections.

(1) Connect the test equipment to Radio Receiver-Transmitter RT-671/PRC-47 as shown in figure 4-1.

(2) Connect the primary power source to the receiver-transmitter.

(3) Turn on the test equipment and place the POWER-LIGHTS switch on RT-671/PRC-47 to POWER ON. Permit the equipment to stabilize at least 5 minutes before beginning the procedures shown in chart below.

Step	Test equipment settings	Radio control settings	Test procedures	Performance standards
1	Adjust signal generator to 2226 kHz; set output level to 1000 microvolts.	Adjust frequency control knobs to 2225 on KILOCYCLES indicator; CW-FSK/VOICE to VOICE; OPR-TUNE to OPR.	Rotate VOLUME control to maximum clockwise stop.	Record audio output voltage across 300-ohm audio load.
2	Same as step 1.	Same as step 1.	Rotate VOLUME control to maximum counterclockwise stop.	Record audio output voltage across 300-audio load. Must be not more Than 1/100 of value recorded in step 1.

4-12. Receiver Audio Output Distortion Test

(fig. 4-2)

a. Test Equipment and Material.

- (1) Signal Generator SG-103/URM-25F.
- (2) Frequency Counter AN/URM-79/U.
- (3) Distortion Analyzer TS-723/U.
- (4) Audio load, 300 ohm 1-watt composition resistor.

(5) Primary power source: 115-volt, 400 Hz, single-phase, 3 amps. 26.5-volt, dc, 11 amperes approx.

b. Test Conditions and Equipment Connections.

(1) Connect the test equipment to Radio Receiver-Transmitter RT-671/PRC-47 as shown in figure 4-2.

(2) Connect the primary power source to the receiver-transmitter.

(3) Turn on the test equipment and place the POWER-LIGHTS switch on RT-671/PRC-47 to POWER ON. Permit the equipment to stabilize at least 5 minutes before beginning the procedures shown in the chart below.

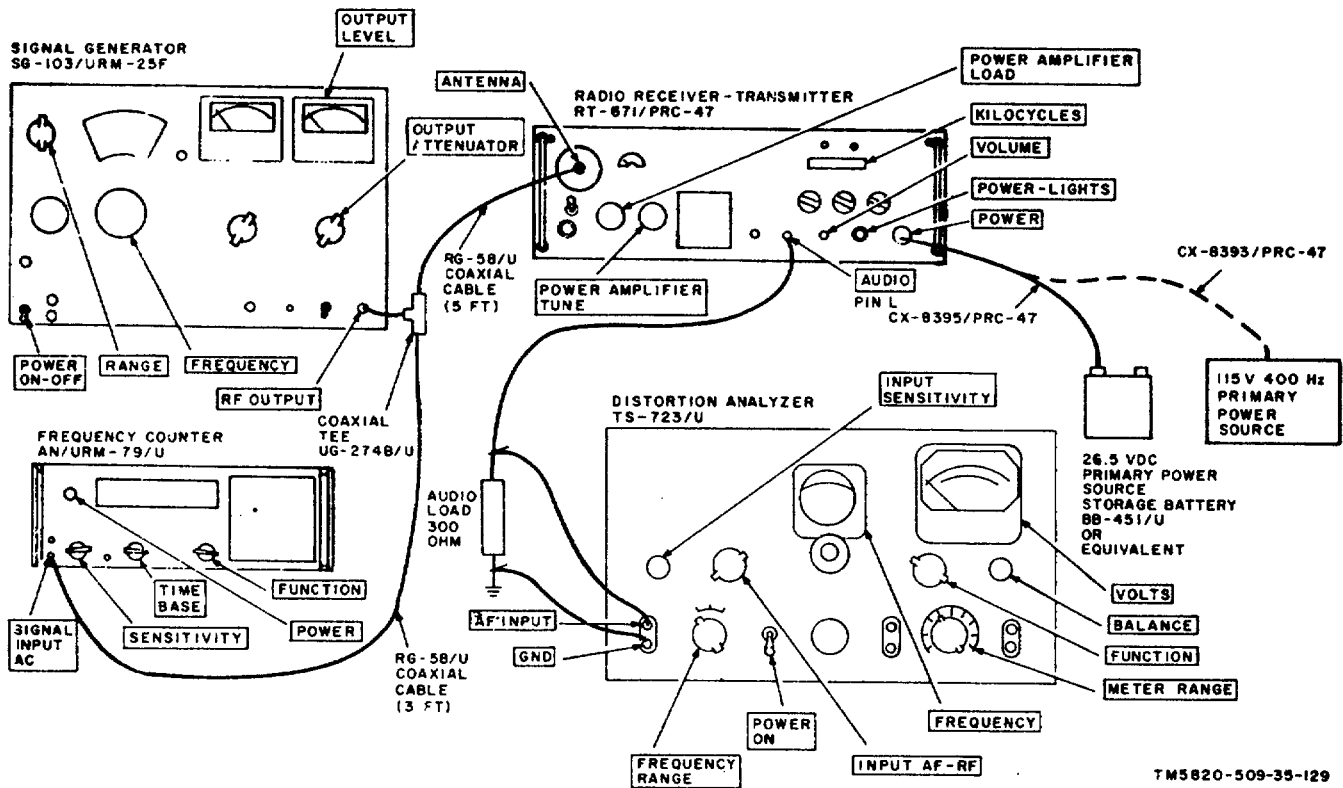

Figure 4-2. Receiver Audio Output Distortion Test, Equipment Setup.

c. Procedure.

Step	Test equipment settings	Radio control settings	Test procedures	Performance standards
1	Adjust signal generator to 2225.3 kHz: set output level to 1000 microvolts	Adjust frequency control knobs to 2225 on KILOCYCLES indicator: CW-FSK/VOICE to VOICE: OPR-TUNE to distortion. OPR.	Set VOLUME control to obtain 12.9 volts across the 300-ohm audio load (500 milliwatts); read	Audio output distortion less than 15%.

4-13. Power Input Requirements, Receive Mode (fig 4-3)

a. Test Equipment and Material.

- (1) Signal Generator SG-103/URM-25F
- (2) Frequency Counter AN /URM 79/U
- (3) Dc ammeter, 0 to 1 ampere. Simpson 375, or equal.
- (4) Audio load, 300-ohm, 1 watt composition resistor.
- (5) Primary power source: 26.5 volt, dc. 11 amperes approx .

(1) Connect the test equipment to Radio Receiver-Transmitter RT-671/PRC-47 as shown in figure 4-3.

(2) Connect the primary power source to the receiver-transmitter.

(3) Turn on the test equipment and place the POWER-LIGHTS switch on RT-671/PRC-47 to POWER ON. Permit the equipment to stabilize at least 5 minutes before beginning the procedures shown in the chart below.

b. Test Conditions and Equipment Connections.

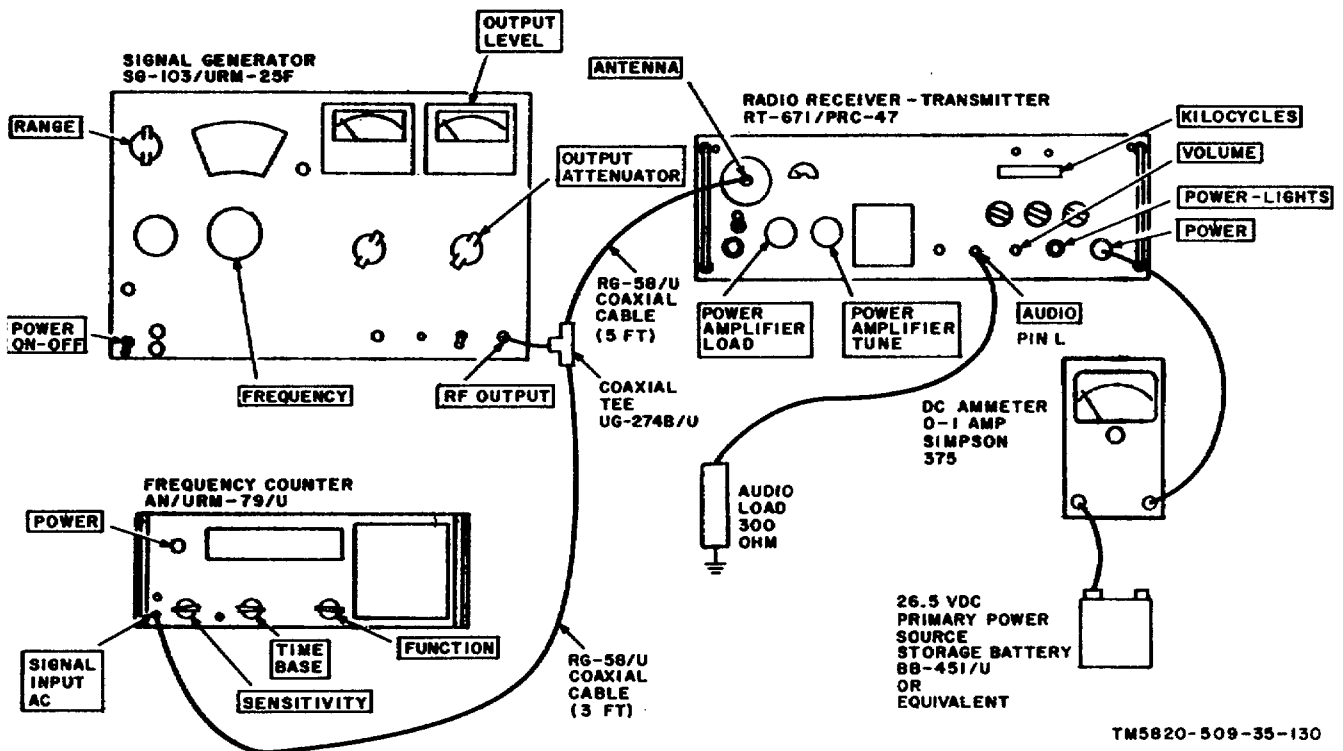

TM5820-509-35-130

Figure 4-3. Receiver Power Input Requirements, Equipment Setup.

c. Procedure.

Step	Test equipment settings	Radio control settings	Test procedures	Performance standards
1	Adjust signal generator to 2226 kHz; set output level to 1000 microvolts.	Adjust frequency control knobs to 2225 on KILOCYCLES indicator; CW-FSK/VOICE to VOICE; OPR-TUNE to OPR.	Read dc ammeter.	Dc ammeter reads not more than 0.875 amperes.

4-14. Transmitter Power Output Test

(fig. 4-4)

a. Test Equipment and Material.

- (1) Antenna simulator (p/o Cable Assembly Set AN/PRA-4)
- (2) Dummy Load DA-75/13
- (3) Multimeter ME-26A/U
- (4) Primary power source: 26.5-volt, dc, 11 amperes approx.

b. Test Conditions and Equipment Connections.

(1) Connect the test equipment to Radio Receiver-Transmitter RT-671/PRC-47 as shown in figure 4-4.

(2) Connect the primary power source to the receiver-transmitter.

(3) Turn on the test equipment and place the POWER-LIGHTS switch on RT-671/PRC-47 to POWER ON. Permit the equipment to stabilize at least 5 minutes before beginning the procedures shown in the chart below.

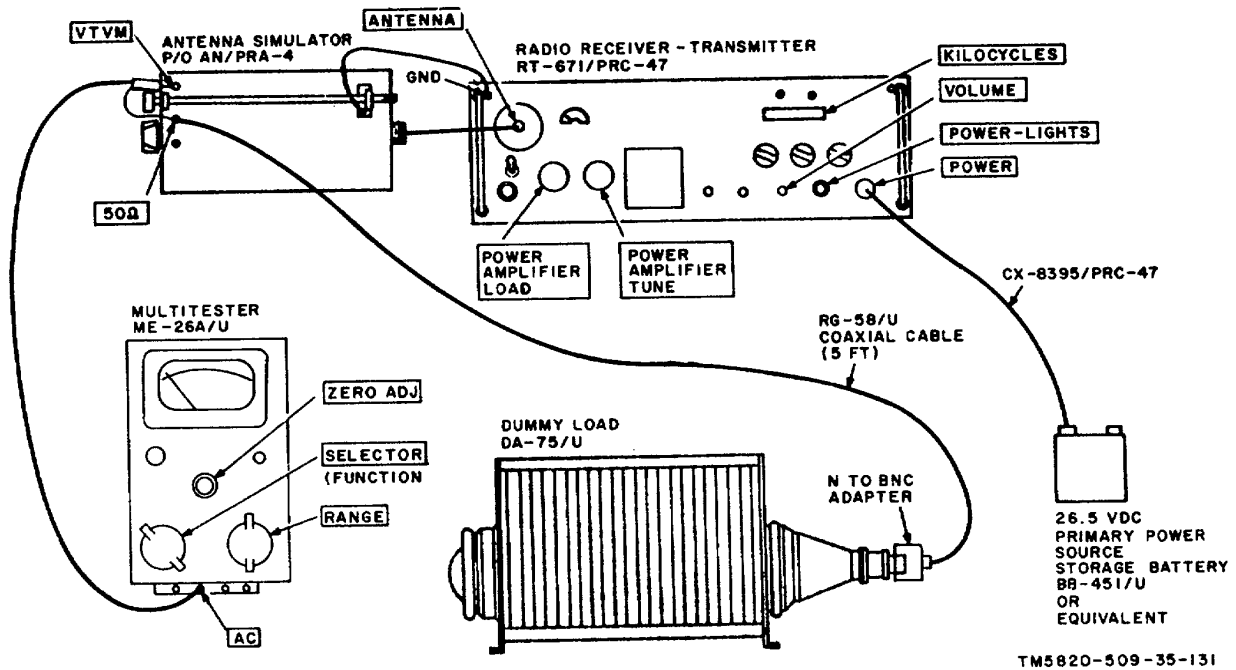

Figure 4-4. Transmitter Power Output and Output Meter Sensitivity Tests, Equipment Setup.

c. Procedure.

- (1) Set the selector switch on the antenna simulator to the 2000 kHz position.
- (2) On RT-671/PRC-47, set the KILOCYCLES indicator to 2000; place CW-FSK/VOICE switch to VOICE; XMTR PWR switch to LO; and OPR-TUNE switch to OAR.
- (3) Place the turns-counters of POWER AMPLIFIER TUNE and POWER AMPLIFIER LOAD controls to the settings recommended on the LOAD-TUNE chart on the front of the receiver-transmitter.

AMPLIFIER TUNE and POWER AMPLIFIER LOAD controls on the front of the receiver-transmitter for maximum deflection on the XMTR OUTPUT meter. Use the OPR-TUNE switch to control power amplifier plate power. Do not permit the power amplifier to operate for more than a few seconds in the unloaded or off-resonant condition, serious equipment damage can result. Between each procedural step of the following chart, resonate the power amplifier output circuit at the new operating frequency.

CAUTION
Before making the following measurements, resonate the POWER

Step	Test equipment settings	Radio control settings	Test procedures	Performance standards
1	a. Set vtvm RANGE switch to 30 VOLTS. b. n/a c. Set vtvm RANGE switch to 100 VOLTS. d. n/a	a. Place OPR-TUNE switch to TUNE. b. n/a c. Place XMTR PWR switch to HI; then place OPR-TUNE to TUNE. d. n/a	a. Read rf voltage across dummy load. b. Immediately return OPH-TUNE switch to OPR. c. Read rf voltage across dummy load. d. Immediately return OPR-TUNE switch to OPR; then place XMTR PWR switch to LO	a. Vtvm reads not less than 13.7 volts rms. b. n/a c. Vtvm reads not less than 30.7 volts rms. d. n/a

Step	Test equipment settings	Radio control settings	Test procedures	Performance standards
2	<p>a. Same as step 1a. Set switch on antenna simulator to 3000 kHz position.</p> <p>b. n/a</p> <p>c. Same as step 1c.</p> <p>d. n/a</p>	<p>a. Same as step 1a except adjust KILOCYCLES indicator to 3000.</p> <p>b. n/a</p> <p>c. Same as step 1c.</p> <p>d. n/a</p>	<p>a. Read rf voltage across dummy load.</p> <p>b. Immediately return OPR-TUNE switch to OPR.</p> <p>c. Read rf voltage across dummy load.</p> <p>d. Immediately return OPR-TUNE switch to OPR; then place XMTR PWR switch to LO.</p>	<p>a. Vtvm reads not less than 15.3 volts rms.</p> <p>b. n/a</p> <p>c. Vtvm reads not less than 34.3 volts rms.</p> <p>d. n/a</p>
3	<p>a. Same as step 1a; set switch on antenna simulator to 4000 kHz position.</p> <p>b. n/a</p> <p>c. Same as step 1c.</p> <p>d. n/a</p>	<p>a. Same as step 1a except adjust KILOCYCLES indicator to 4000.</p> <p>b. n/a</p> <p>c. Same as step 1c.</p> <p>d. n/a</p>	<p>a. Read rf voltage across dummy load.</p> <p>b. Immediately return OPR-TUNE switch to OPR.</p> <p>c. Read rf voltage across dummy load.</p> <p>d. Immediately return OPR-TUNE switch to OPR; then place XMTR PWR switch to LO.</p>	<p>a. Vtvm reads not less than 16.8 volts rms.</p> <p>b. n/a</p> <p>c. Vtvm reads not less than 38.9 volts rms.</p> <p>d. n/a</p>
4	<p>a. Same as step 1a; set switch on antenna Simulator to 5000 kHz position.</p> <p>b. n/a</p> <p>c. Same as step 1c.</p> <p>d. n/a</p>	<p>a. Same as step 1a except adjust KILOCYCLES indicator to 5000.</p> <p>b. n/a</p> <p>c. Same as step 1c.</p> <p>d. n/a</p>	<p>a. Read rf voltage across dummy load.</p> <p>b. Immediately return OPR-TUNE switch to OPR.</p> <p>c. Read rf voltage across dummy load.</p> <p>d. Immediately return OPR-TUNE switch to OPR; then place XMTR PWR switch to LO.</p>	<p>a. Vtvm reads not less than 19.4 volts rms.</p> <p>b. n/a</p> <p>c. Vtvm reads not less than 43.4 volts rms.</p> <p>d. n/a</p>
5	<p>a. Same as step 1a; set switch on antenna simulator to 6000 kHz position.</p> <p>b. n/a</p> <p>c. Same as step 1c.</p> <p>d. n/a</p>	<p>a. Same as step 1a except adjust KILOCYCLES indicator to 6000.</p> <p>b. n/a</p> <p>c. Same as step 1c.</p> <p>d. n/a</p>	<p>a. Read rf voltage across dummy load.</p> <p>b. Immediately return OPR-TUNE switch to OPR.</p> <p>c. Read rf voltage across dummy load.</p> <p>d. Immediately return OPR-TUNE switch to OPR; then place XMTR PWR switch to LO.</p>	<p>a. Vtvm reads not less than 20.6 volts rms.</p> <p>b. n/a</p> <p>c. Vtvm reads not less than 47.5 volts rms.</p> <p>d. n/a</p>
6	<p>a. Same as step 1a; set switch on antenna Simulator to 7000 kHz</p> <p>b. n/a</p> <p>c. Same as step 1c.</p> <p>d. n/a</p>	<p>a. Same as step 1a except adjust KILOCYCLES indicator to 7000.</p> <p>b. N/a</p> <p>c. Same as step 1c.</p> <p>d. n/a</p>	<p>a. Read rf voltage across dummy load.</p> <p>b. Immediately return OPR-TUNE switch to OPR.</p> <p>c. Read rf voltage across dummy load.</p> <p>d. Immediately return OPR-TUNE switch to OPR; then place XMTR PWR switch to LO.</p>	<p>a. Vtvm reads not less than 22.7 volts rms.</p> <p>b. n/a</p> <p>c. Vtvm reads not less than 50.4 volts rms.</p> <p>d. n/a</p>

Step	Test equipment settings	Radio control settings	Test procedures	Performance standards
7	<p>a. Same as step 1a; set switch on antenna Simulator to 8000 kHz position. b. n/a</p> <p>c. Same as step 1c. d. n/a</p>	<p>a. Same as step 1a except adjust KILOCYCLES indicator to 8000. b. n/a</p> <p>c. Same as step 1c. d. n/a</p>	<p>a. Read rf voltage across dummy load. b. Immediately return OPR-TUNE switch to OPR. c. Read rf voltage across dummy load. d. Immediately return OPR-TUNE switch to OPR; then place XMTR PWR switch to LO.</p>	<p>a. Vtvm reads not less than 23.8 volts rms. b. n/a</p> <p>c. Vtvm reads not less than 53.2 volts rms. d. n/a</p>
8	<p>a. Same as step 1a; set switch on antenna simulator to 9000 kHz position. b. n/a</p> <p>c. Same as step 1c. d. n/a</p>	<p>a. Same as step 1a except adjust KILOCYCLES indicator to 9000. b. n/a</p> <p>c. Same as step 1c. d. n/a</p>	<p>a. Read rf voltage across dummy load. b. Immediately return OPR-TUNE switch to OPR. c. Read rf voltage across dummy load. d. Immediately return OPR-TUNE switch to OPR; then place XMTR PWR switch to LO.</p>	<p>a. Vtvm reads not less than 24.7 volts rms. b. n/a</p> <p>c. Vtvm reads not less than 55.3 volts rms. d. n/a</p>
9	<p>a. Same as step 1a; set switch on antenna simulator to 10,000 kHz position. b. n/a</p> <p>c. Same as step 1c. d. n/a</p>	<p>a. Same as step 1a except adjust KILOCYCLES indicator to 10000. b. n/a</p> <p>c. Same as step 1c. d. n/a</p>	<p>a. Read rf voltage across dummy load. b. Immediately return OPR-TUNE switch to OPR. c. Read rf voltage across dummy load. d. Immediately return OPR-TUNE switch to OPR; then place XMTR PWR switch to LO.</p>	<p>a. Vtvm reads not less than 25.7 volts rms. b. n/a</p> <p>c. Vtvm reads not less than 57.4 volts rms. d. n/a</p>
10	<p>a. Same as step 1a: set switch on antenna simulator to 11,000 kHz position. b. n/a</p> <p>c. Same as step 1c. d. n/a</p>	<p>a. Same as step 1a except adjust KILOCYCLES indicator to 11000. b. n/a</p> <p>c. Same as step 1c. d. n/a</p>	<p>a. Read rf voltage across dummy load. b. Immediately return OPR-TUNE switch to OPR. c. Read rf voltage across dummy load. d. Immediately return OPR-TUNE switch to OPR; then place XMTR PWR switch to L1,O.</p>	<p>a. Vtvm reads not less than 26.6 volts rms. b. n/a</p> <p>c. Vtvm reads not less than 59.0 volts rms. d. n/a to</p>
11	<p>a. Same as step 1a: set switch on antenna adjust simulator to 11,999 kHz position. b. n/a</p> <p>c. Same as step 1c. d. n/a</p>	<p>a. Same as step 1a except KILOCYCLES indicator to 11999. b. n/a</p> <p>c. Same as step 1c. d. n/a</p>	<p>a. Read rf voltage across dummy load. b. Immediately return OPR-TUNE switch to OPR. c. Read rf voltage across dummy load d. Immediately return OPR-TUNE switch to OPR; then place XMTR PWR switch to 1,()</p>	<p>a. Vtvm reads not less than 26.6 volts rms. b. n/a</p> <p>c. Vtvm reads not less than 59.8 volts rms. d. n/a</p>

Step	Test equipment settings	Radio control settings	Test procedures	Performance standards
12	<p>a. Same as step 1a; set switch on antenna simulator to 2,000 kHz position.</p> <p>b. n/a</p> <p>c. Same as step 1c.</p> <p>d. n/a</p>	<p>a. Disconnect 26.5 volt dc primary power source; connect 115 volt ac primary power repeat paragraph 4-14c and step 1a of this chart.</p> <p>b. n/a</p> <p>c. Same as step 1c.</p> <p>d. n/a</p>	<p>a. Read rf voltage across dummy load with 115-volt ac primary power source.</p> <p>b. Immediately return OPR-TUNE switch to OPR.</p> <p>c. Read rf voltage across dummy load.</p> <p>d. Immediately return OPR-TUNE switch to OPR; then place XMTR PWR switch to LO and POWER-LIGHTS switch to POWER OFF.</p>	<p>a. Same as step 1a.</p> <p>b. n/a</p> <p>c. Same as step 1c.</p> <p>d. n/a</p>

4-15. Transmitter Output Meter Sensitivity Test
(fig. 4-4)

a. Test equipment and Material

(1) Antenna Simulator (p/o Cable Assembly Set AN/PRA-4) (2) Dummy Load DA-75/U (3) Multimeter ME-26A/U (4) Primary power source: 26.5-volt, dc, 11 amperes approx.

b. Test Conditions and Equipment Connection.

(1) Connect the test equipment to Radio Receiver-Transmitter RT-671/PRC-47 as shown in figure 4-4.

(2) Connect the primary power source to the receiver-transmitter.

(3) Turn on the test equipment and place the POWER-LIGHTS switch on RT-671/PRC-47 to POWER ON. Permit the equipment to stabilize at least 5 minutes before beginning the procedures shown in the chart below.

c. Procedure.

(1) Set the selector switch on the antenna simulator to the 2000 kHz position.

(2) On RT-671/PRC-47. Set the

KILOCYCLES indicator to 2000; place CW-FSK/VOICE switch to VOICE; XMTR PWR switch to LO; and OPR-TUNE switch to OPR.

(3) Place the turns-counters of POWER AMPLIFIER TUNE and POWER AMPLIFIER LOAD controls to the settings recommended on the LOAD-TUNE chart on the front of the receiver-transmitter.

CAUTION

Before making the following measurements, resonate the POWER AMPLIFIER TUNE and POWER AMPLIFIER LOAD controls on the front of the receiver-transmitter for maximum deflection on the XMTR OUTPUT meter. Use the OPR-TUNE switch to control power amplifier plate power. Do not permit the power amplifier to operate for more than a few seconds in the unloaded or off-resonant condition, serious damage can result. Between each procedural step of the following chart, resonate the power amplifier output circuit at the new operating frequency.

Step	Test equipment settings	Radio control settings	Test procedures	Performance standards
1	<p>a. n/a</p> <p>b. n/a</p>	<p>a. Place OPR-TUNE switch to TUNE.</p> <p>b. n/a</p>	<p>a. Adjust M ADJ control until XMTR OUTPUT pointer is at midscale.</p> <p>b. Immediately return OPR-TUNE switch to OPR.</p>	<p>a. Control must be able to adjust pointer to mid-scale.</p> <p>b. n/a</p>
2	<p>a. n/a</p> <p>b. n/a</p>	<p>a. Place XMTR PWR switch to HI; then place OPR-TUNE to TUNF</p> <p>b. n/a</p>	<p>a. Repeat step 1a.</p> <p>b. Immediately return OPR-TUNE switch to OPR; and place XMTR PWR switch to LO.</p>	<p>a. Same as step 1a.</p> <p>b. n/a</p>

Step	Test equipment settings	Radio control settings	Test procedures	Performance standards
3	a. Set switch on antenna simulator to 11,999 kHz position. b. n/a	a. Adjust KILOCYCLES indicator to 11999; place OPR-TUNE switch to TUNE. b. n/a	a. Repeat step 1a. b. Immediately return OPR-TUNE switch to OPR.	a. Same as step 1a. b. n/a
4	a. Same as step 3a. b. n/a	a. Place XMTR PWR switch to HI; then place OPR-TUNE to TUNE. b. n/a	a. Same as step 1a. b. Immediately return OPR-TUNE to OPR; and place XMTR PWR to LO.	a. Same as step 1a. b. n/a

4-16. Transmitter Frequency Stability Test

(fig. 4-5)

a. Test Equipment and Material.

- (1) Oscillator TS-382/U
 - (2) Dummy Load DA-75/U
 - (3) Frequency Counter AN/URM-79/U
 - (4) Output attenuator (fig. 4-5)
 - (5) Blocking capacitor (fig 4-5)
- 4-6 Primary power source: 26.5-volt, dc, 11 amperes approx.

b. Test Conditions and Equipment Connections.

(1) Connect the test equipment to Radio Receiver-Transmitter RT-671/PRC-47 as shown in figure 4-5.

(2) Connect the primary power source to the receiver-transmitter.

(3) Turn on the test equipment and place the POWER-LIGHTS switch on RT-671/PRC-47 to POWER ON. Permit the equipment to stabilize at least 5 minutes before beginning the procedures shown in the chart below.

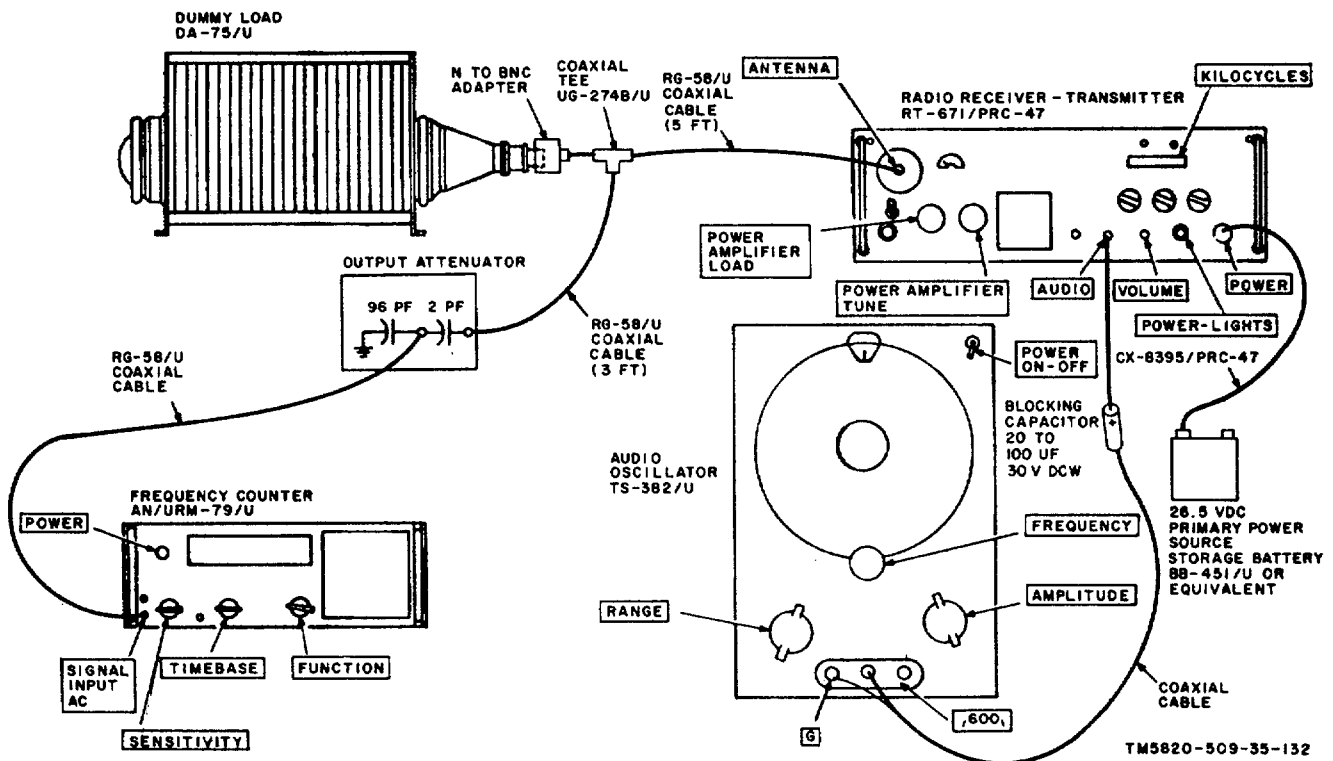

Figure 4-5. Transmitter Frequency Stability Test, Equipment Setup

c. Procedure.

- (1) On RT-671/PRC-47, set the KILOCYCLES indicator to 9900: set CW-

FSK/VOICE switch to VOICE, the XMTR PWR switch to LO, and the OPR-TUNE switch to OAR.

(2) Place the turns-counters of POWER AMPLIFIER TUNE and POWER AMPLIFIER LOAD controls to the settings recommended on the LOAD-TUNE chart on the front of the receiver-transmitter.

CAUTION

Before making the following measurements, resonate the POWER AMPLIFIER TUNE and POWER AMPLIFIER LOAD controls for maximum deflection on the XMTR

OUTPUT meter. Use the OPR-TUNE switch to control power amplifier plate power. Do not permit the power amplifier to operate for more than a few seconds in the unloaded or off-resonant condition, serious equipment damage can result. Between each procedural step of the following chart, resonate the power amplifier output circuit at the new operating frequency.

Step	Test equipment settings	Radio control settings	Test procedures	Performance standards
1	Adjust audio oscillator to 2000 Hz; set output level to 0.1 volt rms.	Place CW-FSK/VOICE switch to CW-FSK.	Measure transmitter output frequency with counter.	Output frequency is 9902 kHz - 10 Hz.
2	Same as step 1.	Same as step 1, except set KILOCYCLES to 9911.	Same as step 1. indicator	Output frequency is 9913 kHz - 10 Hz.
3	Same as step 1.	Same as step 1, except set KILOCYCLES to 9922.	Same as step 1. indicator	Output frequency is 9924 kHz - 10 Hz.
4	Same as step 1.	Same as step 1, except set KILOCYCLES to 9933.	Same as step 1. indicator	Output frequency is 9935 kHz - 10 Hz.
5	Same as step 1.	Same as step 1, except set KILOCYCLES to 9944.	Same as step 1. indicator	Output frequency is 9946 kHz - 10 Hz.
6	Same as step 1.	Same as step 1, except set KILOCYCLES to 9955.	Same as step 1. indicator	Output frequency is 9957 kHz - 10 Hz.
7	Same as step 1.	Same as step 1, except set KILOCYCLES to 9966.	Same as step 1. indicator	Output frequency is 9968 kHz - 10 Hz.
8	Same as step 1.	Same as step 1, except set KILOCYCLES to 9977.	Same as step 1. indicator	Output frequency is 9979 kHz - 10 Hz.
9	Same as step 1.	Same as step 1, except set KILOCYCLES to 9988.	Same as step 1. indicator	Output frequency is 9990 kHz - 10 Hz.
10	Same as step 1.	Same as step 1, except set KILOCYCLES to 9999.	Same as step 1. indicator	Output frequency is 10001 kHz ± 10 Hz.

4-17. Transmitter Power Input Test

(fig. 4-6)

a. Test Equipment and Material.

- (1) Antenna simulator (p/o Cable Assembly Set AN/PRA-4)
- (2) Dummy Load DA-75/U
- (3) Handset H-33G/PT
- (4) Dc ammeter, 0 to 15 amperes, Simpson 375 or equal.

(5) Primary power source: 26.5-volt, dc, 11 amperes approx.

b. Test Conditions and Equipment Connections.

- (1) the test equipment to Radio Receiver-Transmitter RT-671/PRC-47 as shown in figure 4-6.
- (2) Connect the primary power source to the receiver-transmitter.
- (3) Place the POWER-LIGHTS switch on RT-671 /PRC-47 to POWER ON. Permit the equipment to stabilize for at least 5 minutes before beginning the procedures shown in the chart below.

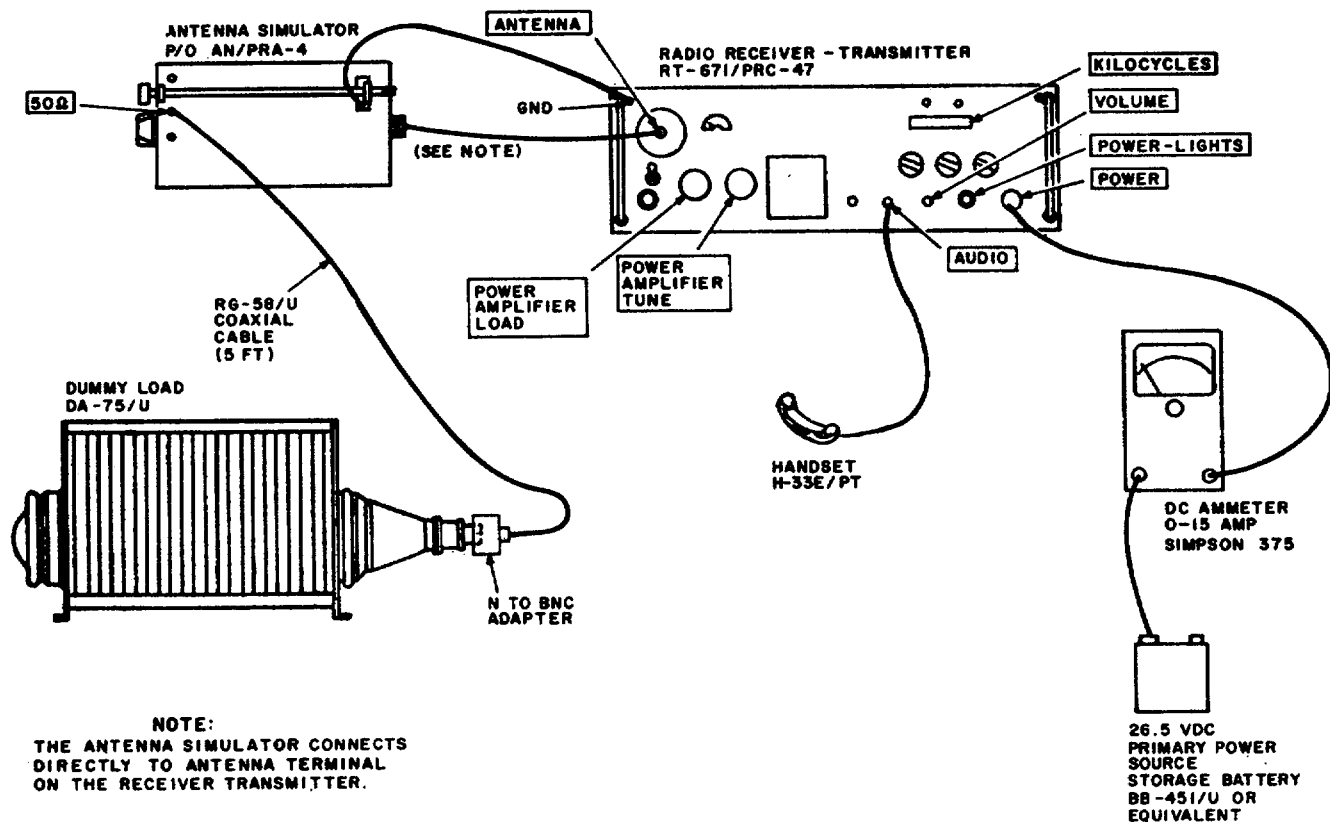

TM5820-509-35-133

Figure 4-6. Transmitter Power Input Test, Equipment Setup.

c. Procedure.

- (1) Set the selector switch on the antenna simulator to the 2000 kHz position.
- (2) On RT 671/PRC 47, set the KILOCYCLES indicator to 2000; set CW-FSK/VOICE switch to VOICE, the XMTR PWR switch to LO, and the OPR-TUNE switch to OAR.
- (3) Place the turns-counters of POWER AMPLIFIER TUNE and POWER AMPLIFIER LOAD controls to the settings recommended on the LOAD-TUNE chart on the front of the receiver-transmitter.

CAUTION

Before making the following measurements, resonate the POWER AMPLIFIER TUNE and POWER AMPLIFIER LOAD controls on the front of the receiver-transmitter for maximum deflection of the XMTR OUTPUT meter. Use the OPR-TUNE switch to control power amplifier plate power. Do not permit the power amplifier to operate for more than a few seconds in the unloaded or off-resonant condition, serious equipment damage can result.

Step	Test equipment settings	Radio control settings	Test procedures	Performance standards
1	n/a	Place XMTR PWR switch to HI and resonate power amplifier output circuit to Maximum output with OPR-TUNE switch in TUNE position.	Return OPR-TUNE switch to OPR and close handset push-to-talk Speak normally into the microphone. Observe dc ammeter reading.	Dc ammeter reads not more than 12.5 amperes. switch.

4-18. Transmitter CW Operation Test

(fig. 4-7)

a. Test Equipment and Material.

- (1) Oscilloscope AN/USM-50.
- (2) Dummy Load DA-75/U.
- (3) Telegraph Key J-45.
- (4) Primary power source: 26.5-volt, dc, amperes approx.

b. Test Conditions and Equipment Connections.

(1) Connect the test equipment to Radio Receiver-Transmitter RT-671/PRC-47 as shown in figure 4-7.

(2) Connect the primary power source to the receiver-transmitter.

(3) Turn on the test equipment and place the POWER-LIGHTS switch on RT-671/PRC-47 to POWER ON. Permit the equipment to stabilize at least 5 minutes before beginning the procedures shown in the chart below.

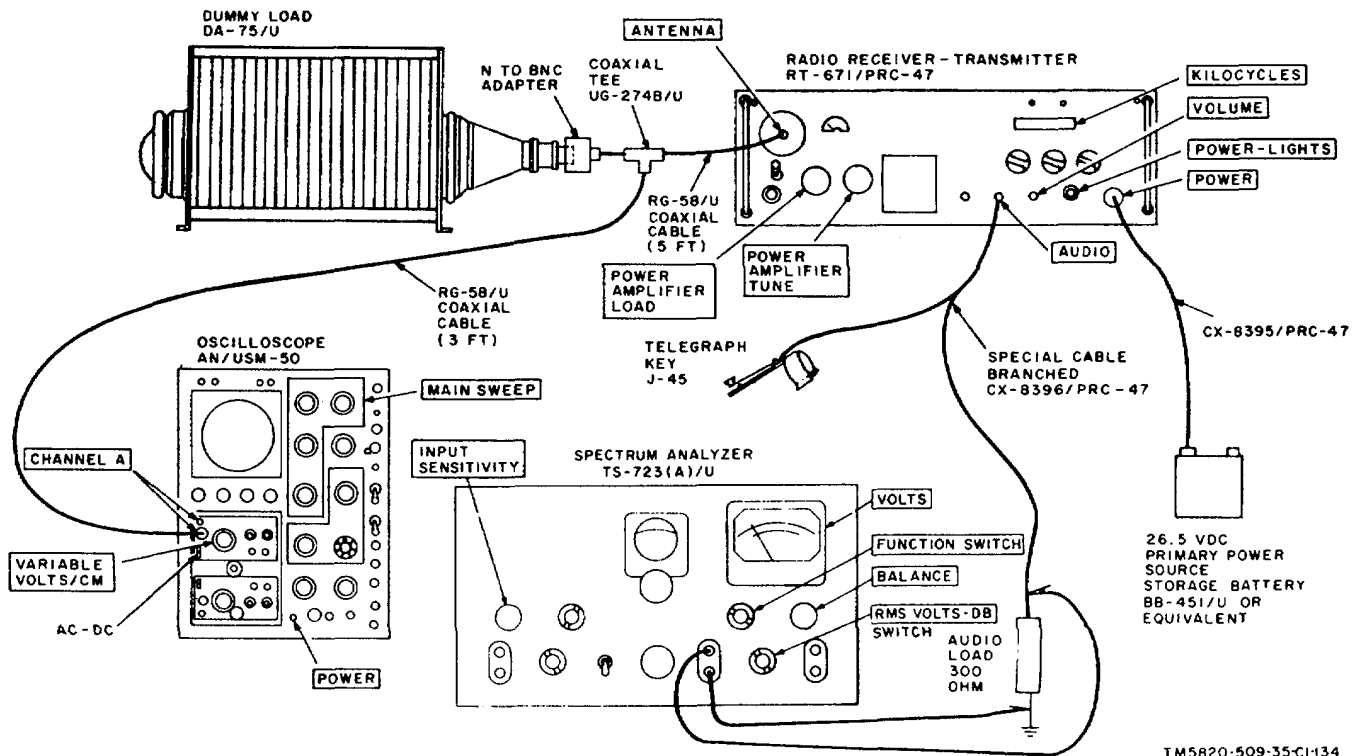

Figure 4-7. Transmitter CW Operation and Sidetone Test, Equipment Setup

TM5820-509-35-C1-134

c. Procedure

(1) On RT-671/PRC-47, set the KILOCYCLES indicator to 2000; place the CW-FSK/VOICE switch to VOICE, the XMTR PWR switch to LO, and the OPR-TUNE switch to OPR.

(2) Place the turns-counters of POWER AMPLIFIER TUNE and POWER AMPLIFIER LOAD controls to the settings recommended on the LOAD-TUNE chart on the front of the receiver-transmitter.

CAUTION

Before making the following measurements, resonate the POWER AMPLIFIER TUNE and POWER AMPLIFIER LOAD controls on the front of the receiver-transmitter for maximum deflection on the XMTR OUTPUT meter. Use the OPR-TUNE switch to control power amplifier plate power. Do not permit the power amplifier to operate more than a few seconds in the unloaded or off-resonant condition, serious equipment damage can result.

Step	Test equipment settings	Radio control settings	Test procedures	Performance standards
1	Adjust oscilloscope sweep to provide a keying envelope display at each keying speed.	Verify that OPR-TUNE switch is at OPR; then place the CW-FSK/VOICE switch to CW-FSK.	Key the transmitter with the telegraph key at speeds from 5- to 25-wpm. Observe the keying envelope for discontinuities.	Transmitter must key at all operating speeds up to 25 wpm without missing character or elements.

4-19. Transmitter Sidetone Test

(fig. 4-7)

a. Test Equipment and Material.

- (1) Spectrum Analyzer TS-723A/U.
- (2) Dummy Load DA-75/U.
- (3) Telegraph Key J-45.
- (4) Audio load, 300-ohm, 1-watt composition resistor.
- (5) Primary power source: 26.5-volt, dc, 11 amperes approx.

b. Test Conditions and Equipment Connections.

- (1) Connect the test equipment to Radio Receiver-Transmitter RT-671/PRC-47 as shown in figure 4-7.
- (2) Connect the primary power source to the receiver-transmitter.
- (3) Turn on the test equipment and place the POWER-LIGHTS switch on RT-671/PRC-47 to POWER ON. Permit the equipment to stabilize for at least 5 minutes before beginning the procedures shown in the chart below.

c. Procedure.

- (1) On RT-671/PRC-47, set the KILOCYCLES indicator to 2000; set CW-FSK/VOICE switch to VOICE, the XMTR PWR switch to LO, and the OPR-TUNE switch to OAR.
- (2) Place the turns-counters of POWER AMPLIFIER TUNE and POWER AMPLIFIER LOAD controls on the front panel of RT-671/PRC-47 to the settings recommended on the LOAD-TUNE! chart.

CAUTION

Before making the following measurements, resonate the POWER AMPLIFIER TUNE and POWER AMPLIFIER LOAD controls on the front panel of the receiver-transmitter. for maximum deflection on the XMTR PWR meter. Use the OPR-TUNE switch to control power amplifier plate power. Do not permit the power amplifier to operate for more than a few seconds at a time in the unloaded or off-resonant condition, serious equipment damage can result.

Step	Test equipment settings	Radio control settings	Test procedures	Performance standards
1	Set meter range switch to 10 VOLTS R.M.S.	Place XMTR PWR switch to HI and peak the power amplifier; return OPR-TUNE to OPR, an switch C W-FSK/VOICE switch to C W-FSK; set VOLUME control to maximum clockwise stop.	Hold telegraph key closed and measure voltage across 300-ohm audio load	Meter reads not less than 3.9 volts rms.
2	Same as step 1.	Same as step 1, except set KILOCYCLES indicator to 11999. Resonate the power amplifier output circuit with XMTR PWR switch at LO and then at HI.	Same as step 1.	Same as step 1.

CHAPTER 5

DEPOT MAINTENANCE

5-1. General

a. Instructions are included in this chapter that detail the adjustment, alignment, and bench checkout of the separate subassemblies of the receiver-transmitter before re-installation of these modules in the radio set following overhaul procedures. Several receiver-transmitter tests are included in this chapter that cannot be performed at lower echelon activities because of the peculiar test equipment requirements.

b. The trouble isolation sections of chapter 3 describe in detail the procedures necessary to isolate trouble within the modules and subassemblies of the receiver-transmitter. The general replacement techniques contained in paragraph 3-8 apply equally to the depot maintenance level.

CAUTION

Remove all power from Radio Receiver-Transmitter RT-671/PRC-47 before beginning any repair procedures.

5-2. Replacement of Parts

a. Parts removal and replacement techniques are described in paragraph 3-9 of this technical manual.

b. Removal and replacement of the plug-in modules and subassemblies of the receiver transmitter are provided in paragraph 3-12.

c. Module disassembly and reassembly techniques are listed in paragraph 3-13.

d. Mechanical subassemblies are disassembled and reassembled using the procedures detailed in paragraphs 3-15 through 3-19. No further special instructions are required in connection with these subassemblies and modules.

5-3. Equipment Adjustments

The following instructions detail complete module and subassembly electrical adjustments and calibrating procedures to assure that the receiver transmitter meets the performance requirements specified by the original procurement document.

5-4. Transmit Mixer Balance and Transmitter Gain Control Adjustment

(fig. 5-1)

a. *Test Equipment and Material.*

- (1) Spectrum Analyzer AN/UPM-110
- (2) Converter, Hewlett-Packard K15-8551B
- (3) Dummy Load DA-75/U
- (4) Attenuator (see fig. 5-1)
- (5) Multimeter ME-26A/U
- (6) Primary power source: 115-volt, 400-Hz, single-phase, 3 amp.

b. *Test Conditions and Equipment Connections.*

(1) Connect the test equipment to Radio Receiver-Transmitter RT-671/PRC-47 as shown in figure 5-1. Do not connect ME-26A/U until instructed to do so.

(2) Connect the primary power source to the receiver-transmitter.

(3) Turn on the test equipment and place the POWER-LIGHTS switch on RT-671/PRC-47 to POWER ON. Permit the equipment to stabilize for at least 5 minutes before beginning the procedures listed in the chart below.

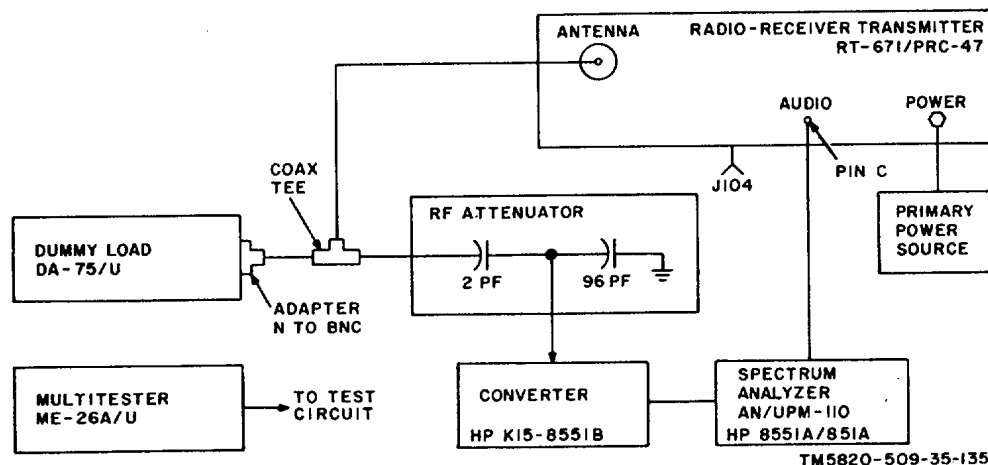

TM5820-509-35-135

Figure 5-1. Transmit Mixer Balance and Transmitter Gain Control Adjustment, Equipment Setup.

c. Procedure.

(1) On the RT-671/PRC-47, set the KILOCYCLES indicator to 11000; place the CW-FSK/VOICE switch to VOICE, XMTR PWR switch to LO, and OPR-TUNE switch to OPR.

(2) Place the turns-counters of POWER AMPLIFIER TUNE and POWER AMPLIFIER LOAD controls to the settings recommended on the LOAD-TUNE chart on the front of the receiver-transmitter .

CAUTION

Before making the following measurements

and adjustments, resonate the **POWER AMPLIFIER TUNE** and **POWER AMPLIFIER LOAD** controls on the front of the receiver-transmitter for maximum deflection on the **XMTR OUTPUT** meter. Use the **OPR-TUNE** switch to control power amplifier plate power. **Do not permit the power amplifier to operate for more than a few seconds in the unloaded condition, serious damage to the equipment can result.**

Step	Test equipment settings	Radio control settings	Test procedures	Performance standards
1	Set spectrum analyzer to 11,000 kHz.	Resonate power amplifier with XMTR PWR switch at HI.	Adjust transmit mixer balance pot A3R150 (fig. 3 95).	Adjust for minimum analyzer reading.
2	Same as step 1	Same as step 1	Immediately return OPR TUNE switch to OPR.	Not applicable.
3	Set multimeter to RF VOLTS, and connect the rf probe to J104 (fig. 3 99).	Place OPR-TUNE switch again to TUNE	Adjust transmit gain control A3R148 (fig. 3-95) clockwise.	Continue to adjust until meter indication stops rising.

5-5. Transmitter Hum Balance Adjustment

(fig. 5-2)

a. Test Equipment and Material.

- (1) Spectrum Analyzer AN/UPM-110
- (2) Converter. Hewlett-Packard K15-8551B
- (3) Dummy Load NA-75/U
- (4) Attenuator (see fig. 5-2).
- (5) Multimeter ME-26A/U
- (6) Audio Oscillator TS-382/U
- (7) Primary power source: 115-volt, 400-Hz, single-phase, 3 amp.

b. Test Conditions and Equipment Connections.

(1) Connect the test equipment to Radio Receiver-Transmitter RT-671/PRC-47 as shown in figure 5-2. Do not connect ME-26A/U until instructed to do so.

(2) Connect the primary power source to the receiver-transmitter.

(3) Turn on the test equipment and place the POWER-LIGHTS switch on the RT-671/PRC-47 to POWER ON. Permit the equipment to stabilize for at least 5 minutes before beginning the procedures listed in the chart below.

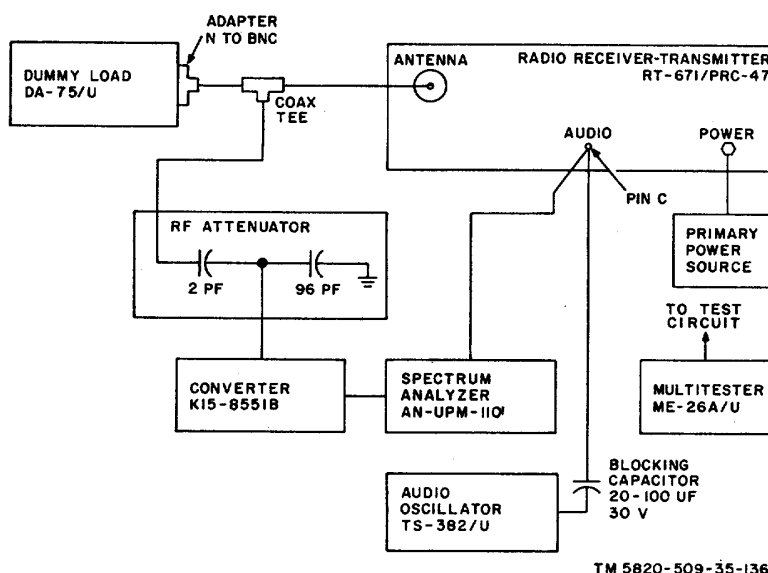

Figure 5-2. Transmitter Hum Balance Adjustment and modulation Fidelity Test, Equipment Setup.

c. Procedure.

(1) On the RT-671/PRC-47, set the KILOCYCLES indicator to 2400; place the CW-FSK/VOICE switch to VOICE, XMTR PWR switch to LO, and OPR-TUNE switch to OPR.

(2) Place the turns-counters of POWER AMPLIFIER TUNE and POWER AMPLIFIER LOAD controls to the settings recommended on the LOAD-TUNE chart on the front of the receiver-transmitter.

CAUTION

Before making the following measurements and adjustments, resonate the POWER AMPLIFIER TUNE and POWER AMPLIFIER

LOAD controls on the front of the receiver-transmitter for maximum deflection on the XMTR OUTPUT meter. Use the OPR-TUNE switch to control power amplifier plate power. Do not permit the power amplifier to operate for more than a few seconds at a time in the unloaded condition, serious equipment damage can result.

(3) After resonating the power amplifier plate circuit at the LO setting of XMTR PWR switch, place the XMTR PWR switch to HI and peak these controls again. Immediately return the OPR-TUNE switch to OPR

Step	Test equipment settings	Radio control settings	Test procedures	Performance standards
1	Adjust audio oscillator to 2800 Hz and set output level to 0.1 volts.	Place CW FSK/VOICE switch to CW-FSK.	Set spectrum analyzer to 2400 kHz and adjust hum balance potentiometer R121 (fig. 3-95).	Adjust R121 for minimum indication at 400 Hz.
2		Return CW-FSK/VOICE switch to VOICE.		

5-6. Transmitter Modulation Fidelity Test

(fig. 5-2)

a. Test Equipment and Material.

- (1) Spectrum Analyzer AN/UPM-110
- (2) Converter, Hewlett-Packard K15-8551B
- (3) Dummy Load DA-75/U
- (4) Attenuator (see fig. 5-2)
- (5) Multimeter ME-26A/U

- (6) Audio Oscillator TS-382/U
- (7) Primary power source: 115-volt, 400-Hz, single-phase, 3 amp.

b. Test Conditions and Equipment Connections.

(1) Connect the test equipment to Radio Receiver-Transmitter RT-671/PRC-47 as shown in figure 5-2. Do not connect ME-26A/U until instructed to do so.

(2) Connect the primary power source to the receiver-transmitter.

(3) Turn on the test equipment and place the POWER-LIGHTS switch on the RT-671/PRC-47 to POWER ON. Permit the equipment to stabilize for at least 5 minutes before beginning the procedures listed in the chart below.

c. Procedure.

(1) On the RT-671/PRC-47, set the KILOCYCLES indicator to 2400; place the CW. FSK/VOICE switch to VOICE, the XMTR PWR switch to LO, and the OPR-TUNE switch to OPR.

(2) Place the turns-counters of POWER AMPLIFIER TUNE and POWER AMPLIFIER LOAD controls to the settings recommended on the LOAD-TUNE chart on the front of the receiver-transmitter.

CAUTION

Before making the following measurements and adjustments, resonate the POWER AMPLIFIER TUNE and POWER AMPLIFIER LOAD controls on the front of the receiver-transmitter for maximum deflection on the XMTR OUTPUT meter. Use the OPR-TUNE switch to control power amplifier plate power. Do not permit the power amplifier to operate for more than a few seconds at a time in the unloaded condition, serious equipment damage can result.

(3) After resonating the power amplifier plate circuit at the LO setting of XMTR PWR switch place the XMTR PWR switch to HI and peel these controls again. Immediately return the OPR-TUNE switch to OPR.

Step	Test equipment settings	Radio control settings	Test procedures	Performance standards
1	Adjust audio oscillator to 1700 Hz and set output level to 0.1 volts.	Place OPR-TUNE switch to TUNE.	Adjust input attenuator on spectrum analyzer so that 1700 Hz tone is at 0 dB reference level.	Set 1700 Hz level for later reference.
2	Adjust audio oscillator to 300 Hz and set output level to 0.1 volts.	Same as step 1.	Read amplitude of 300 Hz tone on spectrum analyzer.	Not more than ± 6 dB from 1700 Hz value measured in step 1.
3	Adjust audio oscillator to 3000 Hz and set output level to 0.1 volts.	Same as step 1.	Read amplitude of 3000 Hz tone on spectrum analyzer.	Not more than ± 6 dB from 1700 Hz value measured in step 1.

5-7. Transmitter Spurious Output Adjustments

(fig. 5-3)

a. Test Equipment and Material.

- (1) Spectrum Analyzer AN/UPM-110
- (2) Converter, Hewlett-Packard K15-8551B
- (3) Dummy Load DA-75/U
- (4) Attenuator (see figure 5-3)
- (5) Audio mixer unit (see figure 5-3)
- (6) Multimeter ME-26A/U
- (7) Audio Oscillator TS-382/U (2 required)
- (8) Primary power source; 115-volt, 400-Hz, single-phase, 3 amps.

b. Test Conditions and Equipment Connections.

(1) Connect the test equipment to Radio Receiver-Transmitter RT-671/PRC-47 as show' in figure 5-3. Do not connect the ME-26A/U until instructed to do so.

(2) Connect the primary power source to the receiver-transmitter.

(3) Turn on the test equipment and place the POWER-LIGHTS switch on the RT-671/PRC-4' to POWER ON. Permit the equipment to stabilize for at least 5 minutes before beginning the procedures listed in the chart below.

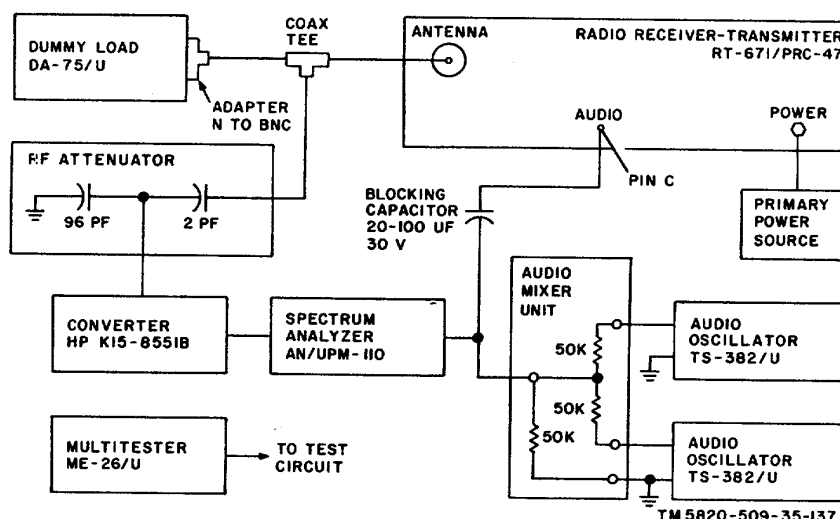

Figure 5-3 Transmitter Spurious Outputs Adjustment. Equipment Setup

c. Procedure.

(1) On RT-671/PRC-47, set the KILOCYCLES indicator to 2400; place the CW-FSK/VOICE switch to VOICE, the XMTR PWR switch to LO, and the OPR-TUNE switch to OPR.

(2) Place the turns-counters of POWER AMPLIFIER TUNE and POWER AMPLIFIER LOAD controls to the settings recommended on the LOAD-TUNE chart on the front of the receiver-transmitter.

CAUTION

Before making the following measurements and adjustments, resonate the POWER AMPLIFIER TUNE and POWER AMPLIFIER LOAD controls on the front of the receiver-transmitter for maximum deflection on the XMTR OUTPUT meter. Use the OPR-TUNE switch to control power amplifier plate power. Do not permit the power amplifier to operate

for more than a few seconds at a time in the unloaded condition, serious equipment damage can result.

(3) After resonating the power amplifier plate circuit at the LO setting of XMTR PWR switch, place the XMTR PWR switch to HI and repeat the peaking procedure.

(4) Return the OPR-TUNE switch to OPR.

(5) Adjust the spectrum analyzer to 2400 kHz; set the audio oscillators to 900 Hz and 2800 Hz respectively at an output level of 0.1 volts per tone.

NOTE

Adjust the driver bias between -30 and -55 volts dc and the power amplifier grid bias between -105 and -115 volts dc to obtain the minimum distortion products.

Step	Test equipment settings	Radio control settings	Test procedures	Performance standards
1		Place CW-FSK/VOICE switch to CW-FSK Switch to CW-FSK	Measure third-order distortion product above the passband (above 2404.6 kHz).	Not less than 30 dB down from peak envelope power output level.
2		Same as step 1.	Measure third-order distortion product below the passband (below 2399.0 kHz).	Same as step 1.
3	Reduce output of 900-Hz Oscillator to zero.	Same as step 1.	Measure carrier amplitude (2400.0 kHz).	Not less than 40 dB down from peak envelope power output level.
4	Same as step 3.	Same as step 1.	Measure amplitude of 2800 Hz sideband that occurs below the carrier (2397.2 kHz).	Not less than 60 dB down from peak envelope power output level.

CHAPTER 6

DEPOT OVERHAUL STANDARDS

Section I. GENERAL

6-1. Scope

This chapter contains the depot-level performance standards tests and defines the acceptable limits of operational performance for a repaired Radio Set AN/PRC-47. Section I contains general information applicable to the test procedures and test equipment, and includes construction details and schematic diagrams for special test fixtures required for bench test of modular subassemblies of the AN/PRC-47. Section II lists the performance tests and specific procedures to be conducted for the evaluation and adjustment of plug-in modules of the radio set. These tests are

conducted using the bench test facilities provided by the special test fixtures described in section I. Section II I tabulates the overall equipment performance tests indicated elsewhere in this technical manual, lists the overall equipment adjustments and alignment routines, and provides a table of final equipment standards of performance.

6-2. General

a. The following table provides a list of test equipment required for performance of these standards tests.

<i>Test equipment</i>	<i>FSN</i>	<i>Technical manual</i>
Ac Ammeter, 0.5 amperes (Weston #904, or equal)		
Ac Voltmeter, 10 mv to 15,000 mv 12500 volts dc insulation)		
Audio Oscillator TS-382/U	6625-246-8729	TM 11-6625-935-12
Cable Assembly Set AN/PRA-4	5995-973-3686	
Coaxial Adapter, Tee UG-28A/U		
Coaxial Adapter, Tee UG-274B/U		
Dc Ammeter 0-1 ampere (Simpson #375. or equal)		
Dc Ammeter 0-15 ampere (Simpson #375, or equal)		
Distortion Analyzer TS-723/U		
Frequency Counter AN/URM-79/U		
Multimeter ME-26A/U	6625-542-6407	TM 11-6625-200-15
Oscilloscope AN/USM-50		TM 11-5129
Output Meter TS-585/U		TM 11-5017
Power Supply, 7 vdc 600 ma (Harrison 6203B, or equal)		
Power Supply, 26 vdc, 500 ma (Harrison 6202B, or equal)		
Power Supply, 26 vdc, 15 Amp. (Harrison 6434B, or equal)		
Power Supply, 110 vdc, 5 ma. (Harrison 6207B, or equal)		
Radar and Radio Repair Tool Kit TK-115/G		
Receiver R-1433/UR		
Resistance Decade Box MX-3991/V		
Signal Generator SG-103/URM-25F (2 required)		
Spectrum Analyzer AN/UPM-110		TM 11-6626-326-12
Up-converter for AN /UPM - I 10 (Hewlett Packard K 15-855 1B)		
Voltmeter ME-30A/U		

b. The following table lists the special tools and test fixtures required for performance standards tests

<i>Special tool</i>	<i>FSN</i>	<i>Ref drawing</i>
Gage. thickness (feeler) 0.002 to 0,020	5210-031-1504	Fig. 6-1
Gage, plug (depth) (u/w CV-1377A/PRC-47)		Fig. 6-2
Gage, overtravel 0.041.inch		Fig. 6-3
Output attenuator, 50: 1		Fig. 6-4
Test fixture for AM-3506/PRC-47		Fig. 6-5
Test fixture for AM-3507/PRC-47		Fig. 6-6
Test fixture for CV-1377A/PRC-47		Fig. 6-7
Indexing fixture for CV-1377A/PRC-47		Fig. 6-8
Test fixture for PP-3518/PRC-47		Fig. 6-9
Test fixture for 0-1032/PRC-47		Fig. 6-10
Test fixture for C-4311/PRC-47		

c. Suggested parts locations, parts lists and schematic diagrams for the test fixtures listed above are described in section III of this chapter. All pertinent construction details are shown for convenience.

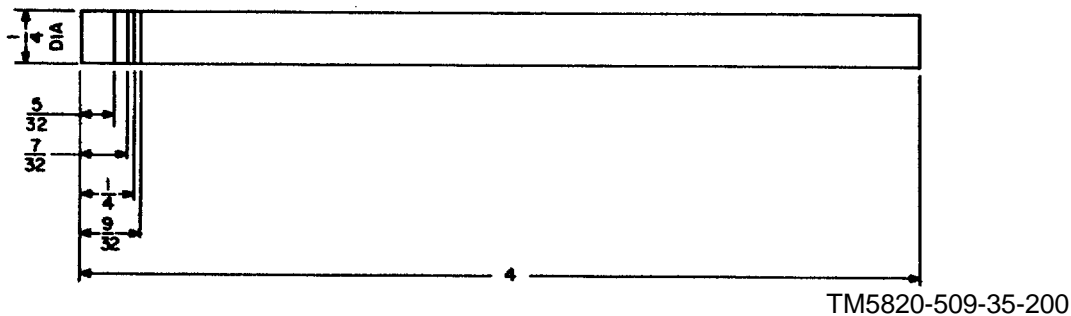

Figure 6-1. Plug Gage, Slug Adjustment

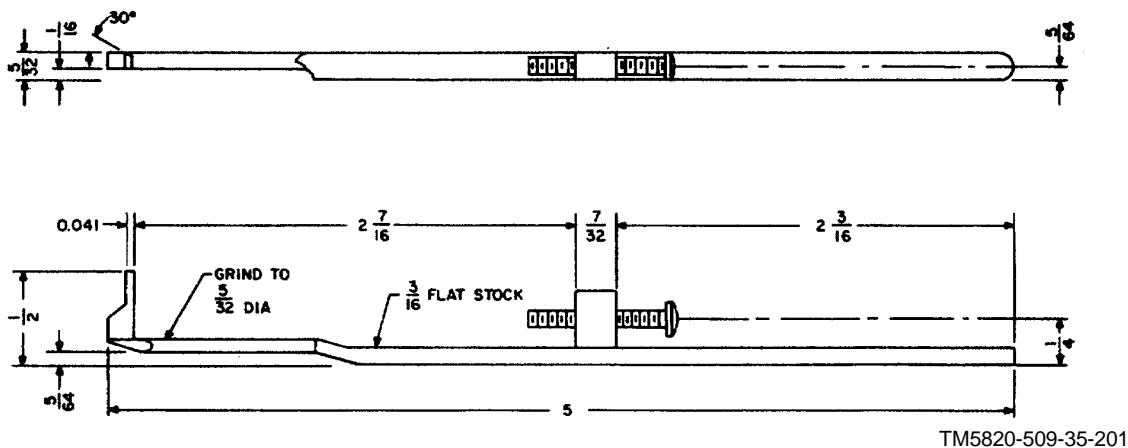

Figure 6-2. Gage, Overtravel. 0.041-inch.

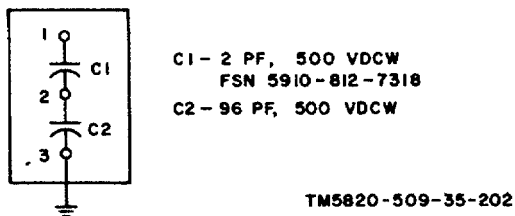

Figure 6-3. Output Attenuator, 50:1.

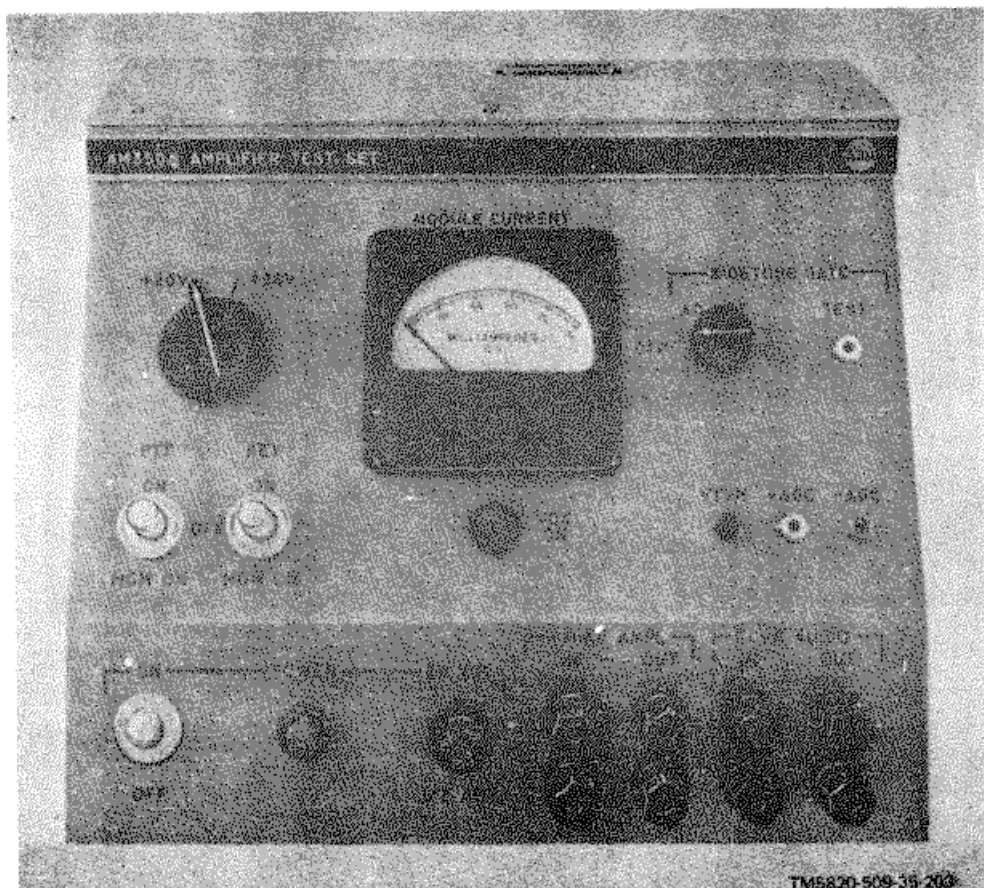

Figure 6-4. Test Fixture for AM-3506/PRC-47, Suggested Layout.

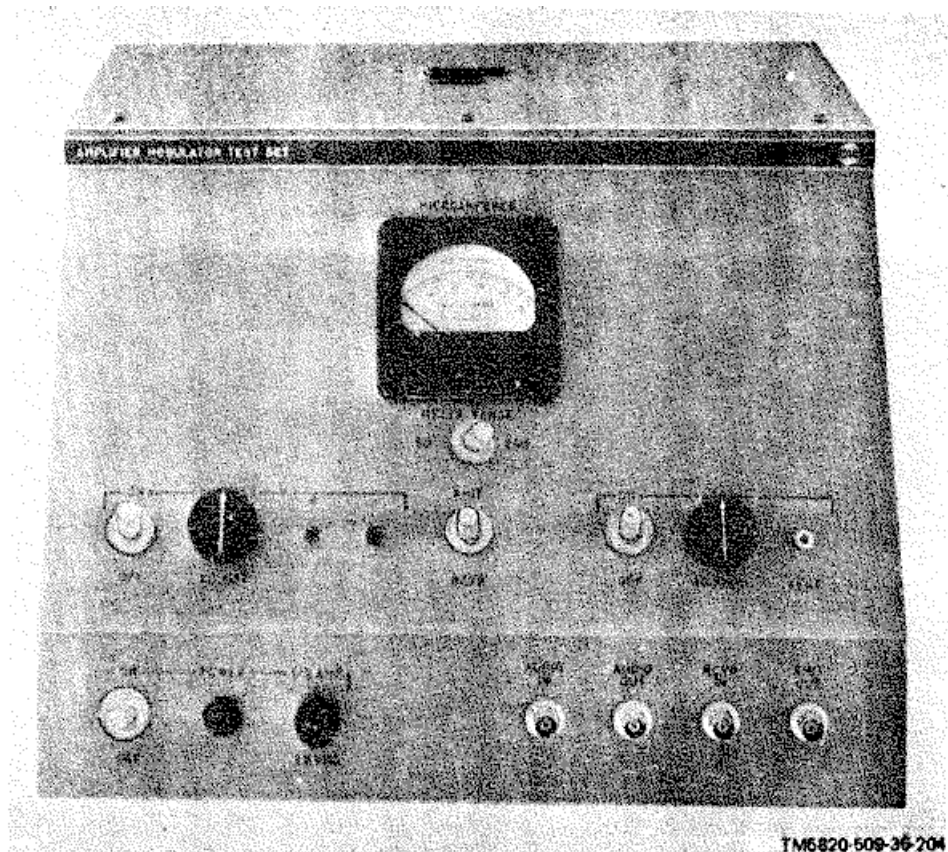

Figure 6-5. Test Fixture for AM-3507/PRC-47, Suggested Layout.

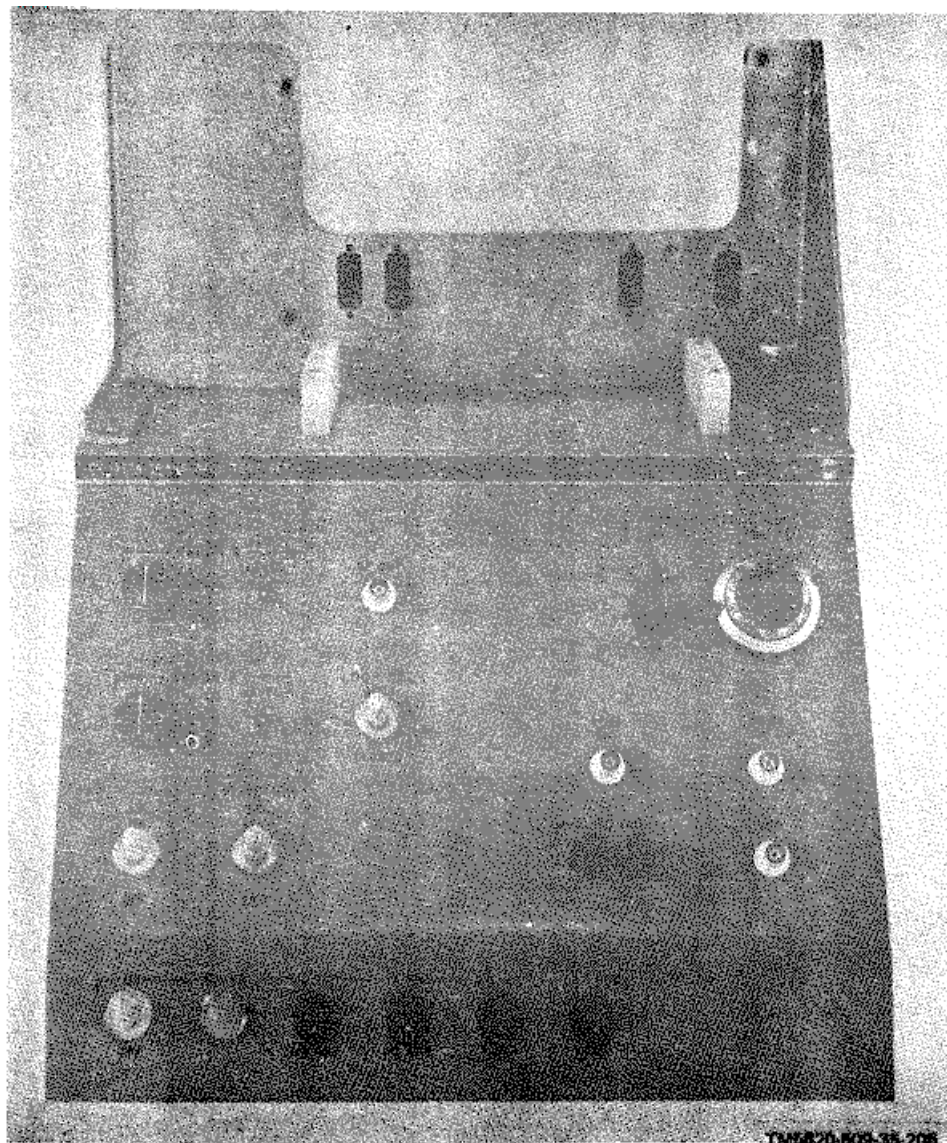

Figure 6-6. Test Fixture for CV-1377A/PRC-47, Suggested Layout.

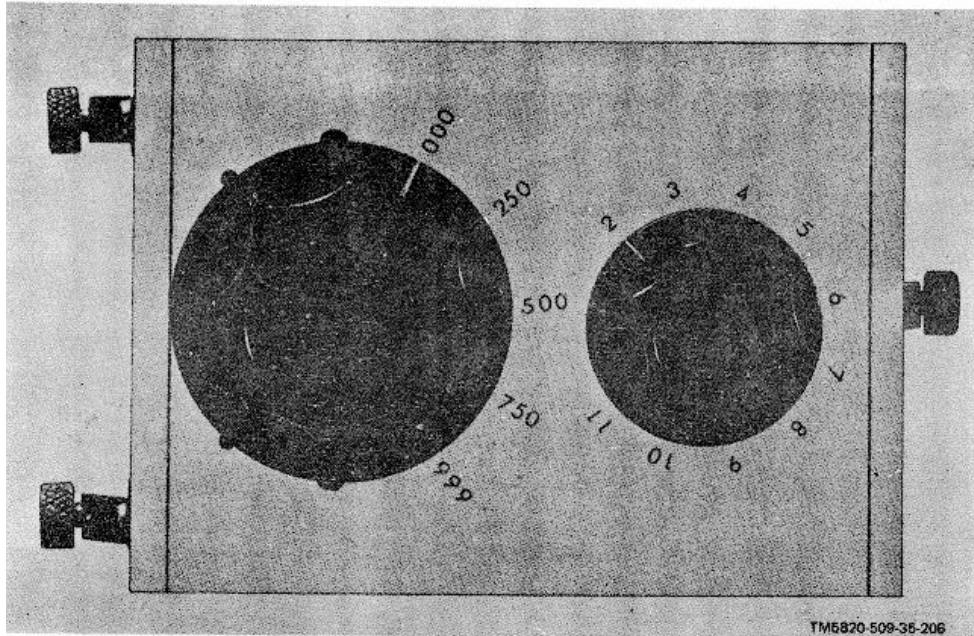

Figure 6-7. Indexing Fixture for CV 1377A/PRC, Suggested Layout.

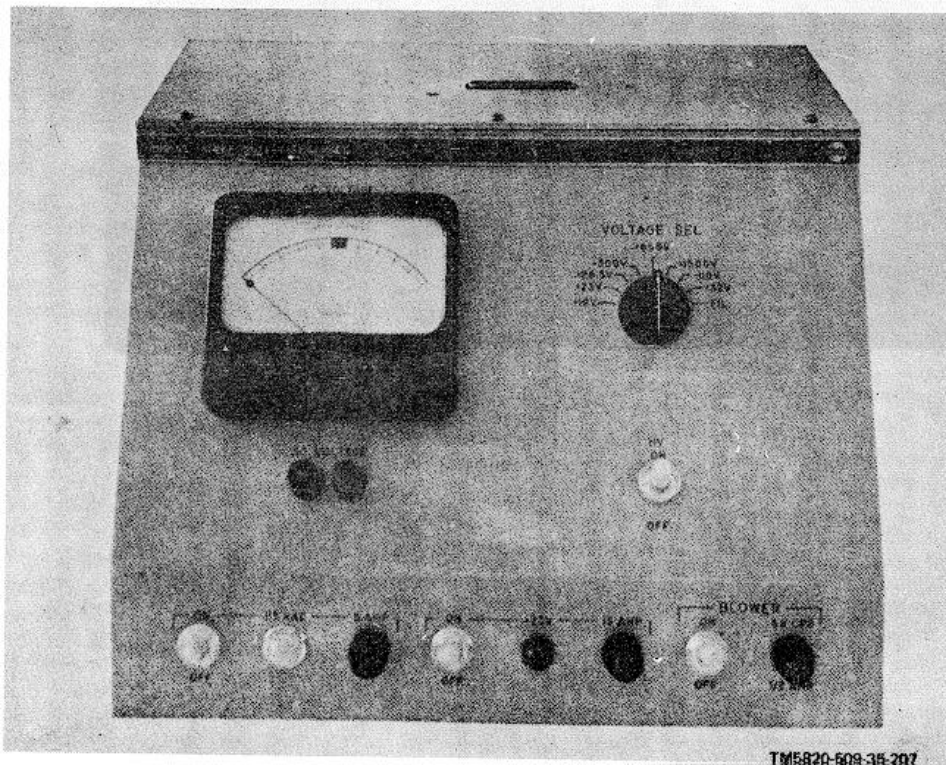

Figure 6-8. Test Fixture for PP-3518/PRC-47, Suggested Layout.

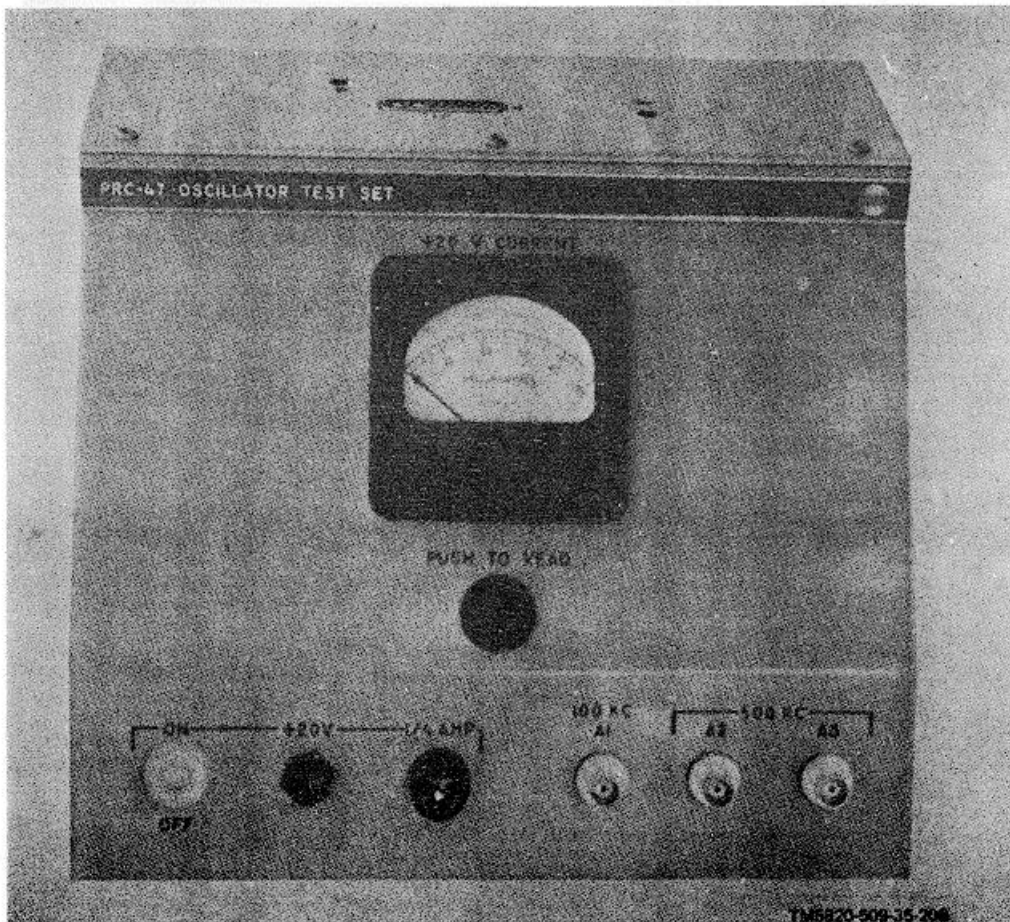

Figure 6-9. Test Fixture for O-1032/PRC-47, Suggested Layout.

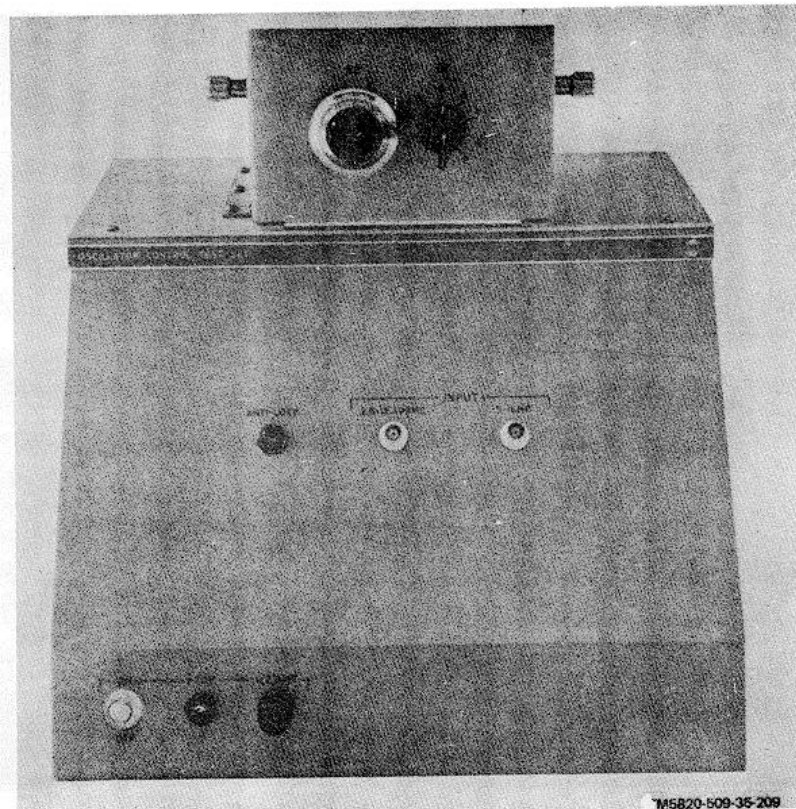

Figure 6-10. Test Fixture for C-4311/PRC-47, Suggested Layout.

6-3. Test Facilities

A primary power source of 115 volts, 400-Hz, single-phase alternating current at approximately 3.0 amperes, and a 26.6-volt direct current primary power source at approximately 16 amperes is required for these tests. In addition, normal test instrument primary power facilities (60- or 400- Hz) will be required. The test fixtures, or their equivalent, shown in figures 6-4 through 6-10, will be required.

6-4. Modification Work Orders

The performance standards listed in the following tests assume that all modification work orders (MWO's) have been performed. Consult DA Pam 310-7 for a list of MWO's for Radio Set AN/PRC-47.

6-5. Physical Tests and Inspection

Perform general inspection of all modular

subassemblies of the radio set to determine whether the defective circuit has been repaired. If doubt arises as to the completeness of the repair procedures, a limited number of performance standards tests will verify circuit performance.

6-6. Reference Standards Tests

The following reference standards tests are required to provide assurance that satisfactory operating parameters have been maintained or restored as a result of depot overhaul procedures. Each group of tests, performed on a specific modular subassembly, is conducted using the test fixture for that module together with the equipment configuration specified in the procedure. Certain initial conditions must be established before the performance tests and reference standards can be judiciously compared. Unless specified, all tests shall be performed in the order listed in the procedures to avoid ambiguity.

6-7. Tests to be Performed

a. *Audio Amplifier AM-3506/PRC-47*. The following tests must be performed using the test fixture for the AM-3506/PRC-47 (fig. 6-4). A schematic diagram, parts layout photographs and parts lists for this test fixture are included in section III.

- (1) Initial settings and adjustments.
- (2) Maximum output levels, receive mode.
- (3) Frequency response and distortion, receive mode.
- (4) AVC signal gate operation, receive mode.
- (5) Harmonic distortion and frequency response, transmit mode.
- (6) Frequency response at nominal output, transmit mode.
- (7) CW oscillator operation test.6-7.

b. *Amplifier-Modulator AM-3507/PRC-47*. The following tests must be performed using the test fixture for AM-3507/PRC-47 (fig. 6-5). A schematic diagram, parts layout photographs, and parts lists for this test fixture are included in section III.

- (1) Initial settings and adjustments.
- (2) Output, receive mode.
- (3) Distortion.
- (4) Selectivity.
- (5) Response, receive mode.

c. *Signal Data Translator CV-1377A/PRC-47*. The following tests are to be performed using the test fixture for CV-1377A/PRC-47 (fig. 6-6) together with the indexing fixture (fig. 6-7). Configuration drawings, parts layout photographs, parts lists and schematic diagrams for these test fixtures are included in section III.

- (1) Mechanical alignment.
- (2) 5- to 14-MHz ringer circuit alignment.
- (3) Oscillator output adjustment.
- (4) Oscillator alignment and tracking adjustment
- (5) Rf alignment, receive mode.
- (6) Rf alignment, transmit mode.
- (7) Oscillator control isolation amplifier test.

d. *Power Supply PP-3518/PRC-47*. The following tests must be performed using the test fixture for PP-3518/PRC-47 (fig. 6-8). A schematic diagram, parts layout photographs, and parts lists for this test fixture are included in section III.

- (1) Initial settings and adjustments.
- (2) Performance tests, 26.5-volts dc primary power source.

- (a) Input current.
- (b) Power amplifier plate voltage.
- (c) Power amplifier screen voltage.
- (d) Driver plate voltage.
- (e) Relay voltage.
- (f) Filtered low voltage.
- (g) Regulated voltage.
- (h) Filament voltage.
- (i) Power amplifier bias voltage.
- (j) Driver bias voltage.
- (k) Voltage regulator operation.

(3) Performance tests, 110-volts, 400-Hz primary power source.

- (a) Input current.
- (b) Relay voltage.
- (c) Filtered low voltage.
- (d) Regulated voltage.
- (e) Filament voltage.

e. *Radio Frequency Oscillator O-1032/PRC-47*. The following tests must be performed using the test fixture for O-1032/PRC-47 (fig. 6-9). A schematic diagram, parts layout photographs, and parts lists for this test fixture are included in section III.

- (1) Initial settings and adjustments.
- (2) Locked oscillator, divider, and output amplifier performance.
- (3) Locked oscillator Q4 and 500-kHz amplifier adjustments.
- (4) Locked oscillator Q8 and 100-kHz amplifier adjustments.
- (5) Final frequency calibration.

f. *Oscillator Control C-4311/PRC-47*. The following tests must be performed using the test fixture for the C-4311/PRC-47 (fig. 6-10). A schematic diagram, parts layout photographs, and parts lists for this test fixture are included in section III.

- (1) Pulse generator output.
- (2) 1.8- to 0.9-MHz ringer circuit alignment.
- (3) Crystal oscillator alignment.
- (4) 601- to 600-kHz filter test.
- (5) 550- to 750-kHz filter test.
- (6) Frequency discriminator test.
- (7) Error voltage balance adjustment.
- (8) Anti-lock test.
- (9) SMO mixers test.

6-8. Reference Standards

The following chart lists the reference standards procedures and the expected result or standard value.

Section	Action required	Reference standard
AM -3506/PRC-47	<ol style="list-style-type: none"> 1. Make initial settings and adjustments. 2. Record maximum output levels, receive mode. 3. Record frequency response and distortion, receive mode. 4. Record AVC signal gate operating level. 5. Measure input level and record harmonic distortion and frequency response below the clipping and compression threshold levels. 6. Record frequency response at nominal output level. 7. Record operation of CW oscillator 	<ol style="list-style-type: none"> 1. <ol style="list-style-type: none"> (a) Set R54 for 1 watt output. (b) Set R27 for 3.5 volts p-p at MIKE AMPL OUT jack. (c) Set R40 so that VOX ON lamp lights. (d) Set R46 for 20 volts pep at RX AUDIO OUT jack. Waveshape is symmetrical. 2. <ol style="list-style-type: none"> (a) At RX AUDIO OUT jack, not less than 1 watt (18 volts rms across 300 ohms). (b) At +AGC jack, not less than +14 volts dc. (c) At -AGC jack, more negative than -5.5 volts dc. 3. <ol style="list-style-type: none"> (a) Frequency response shall not vary more than ± 3 dB from the 1700 Hz value in range from 300 to 3000-Hz. (b) Distortion shall be no more than 8% in range from 300 to 3000-Hz. (c) +AGC jack, not less than 7.0 volts dc in range from 300 to 3000 Hz. (d) -AGC jack, not less than -3.0 volts dc in range from 300 to 3000 Hz. 4. + AGC jack, not more than 0.5 volts dc. 5. <ol style="list-style-type: none"> (a) Input level not more than 0.015 volts rms At 1700 Hz for sinusoidal output. (b) Harmonic distortion shall not exceed 5% from 300. to 3000. Hz. (c) Frequency response shall not vary more than ± 2.5 dB from the 1700 Hz value in the range from 300- to 3000-Hz. 6. Frequency response shall not vary more than ± 2.0 dB from the 1700 Hz value in the range from 300 To 3000.Hz 7. <ol style="list-style-type: none"> (a) MIKE AMPL OUT jack, 3.5 volts peak-to-peak. (b) MIKE AMPL OUT jack, 800 ± 50 Hz. (c) No clicks or chirps heard in loudspeaker. (d) VOX ON lamp lights.
AM-3507/PRC-47	<ol style="list-style-type: none"> 1. Make initial settings and adjustments. 2. Perform output test, receive mode. 3. Record distortion in audio pass. band. 4. Record selectivity 5. Record frequency response. receive mode. 	<ol style="list-style-type: none"> 1. <ol style="list-style-type: none"> (a) Set C15, C17, L6, L7, and T3 for maximum at AUDIO OUT jack. (b) Select value of R14, if necessary. to obtain 0.5 volts rms at XMTR OUT jack. (c) Set R5 and C35 for minimum carrier leakage at XMTR OUT jack. 2. Read signal generator output necessary to produce 0.1 volt rms at AUDIO OUT jack. shall not exceed 200 microvolts. 3. <ol style="list-style-type: none"> (a) Read AUDIO OUT jack. not more than 5% from 497.0 to 499.7 kHz. (b) Oscilloscope at AUDIO OUT shows no spikes or ripple with 0.05 volt input signal and AGC switch on. 4. The frequency difference between -60 dB points in the pass band shall not be more than 6.0 kHz. 5. Frequency response shall not vary more than 3 db above, nor 4 dB below the reference value at 498.3 kHz in the range from 497.0 to 499.7 kHz.
CY-1377A/PRC 47	<ol style="list-style-type: none"> 1. Perform mechanical alignment. 2. Align 5- to 14-MHz ringer circuit. 	<ol style="list-style-type: none"> 1. <ol style="list-style-type: none"> (a) Set slugs of L1 L2. and L3 to a depth of 7/32 from bottom of coil form. (b) Set slug of L4 to depth of 5/32 from bottom of coil form. (c) Set slug of L5 to depth of 1/4 from bottom of coil form. (d) Set slug of L145 to depth of 9/32 from bottom of coil form. 2. Set C248. C250. C252. C254. C256, C258. C260, C262, C264 and C266 At 1-MHz increments for maximum output at 5 to 14 MHz jack. Must Be at least 0.9 volt peak to-peak.

Section	Action required	Reference standard
PP-3518/PRC-47	<ol style="list-style-type: none"> 3. Record oscillator output. 4. Align and track oscillator. 5. Align and adjust receive rf circuit a. 6. Align and adjust transmit rf circuits. 7. Record oscillator control isolation amplifier output. 1. Perform initial settings and adjustments. 2. Record fully loaded primary input current using 23.0 volts dc input voltage. 3. Record all power supply output voltages and the ripple content of each with 23.0 volts dc primary input power. 4. Record fully loaded primary input current using 110 volts, 400-Hz primary power source. 5. Record all power supply output voltages and the ripple content of 	<ol style="list-style-type: none"> 3. Output at midpoint of slug rack for each band, not less than 1.0 volt rms at VFO jack. 4. (a) Set inductors L125 through L144 to obtain calibration within ± 1 kHz at each end of all bands. (b) Record tracking deviation at 000, 250, 500, 750 and 999 on the slug rack control for each band. Maximum deviation not more than ± 12 kHz. 5. Peak inductors L7-L16, L22-L31, L37-L46, and L52 L61 for maximum if. output. Level shall not be less than 0.04 volt rms at each .5-MHz increment of all bands. 6. Peak inductors L5, and L67 to L76 for maximum rf output. Level shall be between 30 and 300 millivolts rms. 7. (a) VFO jack, not less than 1.0 volt rms at 2.0 MHz. (b) VFO jack, not less than 1.0 volt rms at 12.0 MHz. 1. (a) DC VOLTAGE meter reads in +18V, +23V, and +26.5V positions of VOLTAGE SEL switch with HV ON-OFF switch at OFF. (b) DC VOLTAGE meter reads in all positions except FIL of VOLTAGE SEL switch with HV ON/OFF switch at ON. Ac voltmeter reads approximately 6.3 volts rms in FIL position of VOLTAGE SEL switch. (c) Set potentiometer A5R22 to $+ 19.0 \pm 0.4$ volts dc at test point A5J8. (d) Set potentiometer A5R3 to -110 ± 5.5 volts dc at test point A5J2. (e) Set potentiometer A5R4 to -32 ± 1.6 volts dc at test point A5J1. 2. Dc ammeter reads not more than 12.5 amperes. 3. (a) PA plate voltage: In red portion of DC VOLTAGE meter; ripple less than 3.75 volts rms. (b) PA screen voltage: In red portion of DC VOLTAGE meter; ripple less than 1.5 volts rms. (c) Driver plate voltage: In red portion of DC VOLTAGE meter; ripple less than 0.20 volt rms. (d) Relay voltage: In red portion of DC VOLTAGE meter. (e) Filtered low voltage: In red portion of DC VOLTAGE meter; ripple less than 0.075 volt rms. (f) Regulated voltage: In red portion of DC VOLTAGE meter; ripple less than 0.01 volt rms. Range of adjustment from 18.0 to 20.0 volts dc; set to 19.0 ± 0.4 volts. (g) Filament voltage: 6.0 to 6.3 volts peak on oscilloscope. (h) PA bias voltage: Set to -110 ± 1.0 volts; ripple less than 0.10 volt rms. Driver bias voltage: Set to -32.0 ± 0.5 volts; ripple less than 0.05 volt rms. (j) Voltage regulator operation: Output from 18.5 to 19.5 volts dc as input is varied from 22.0 to 28.0 volts dc 4. Ac ammeter reads not more than 3.0 amperes with ac mains between 97.8 and 112.2 volts at 380 to 420 Hz. 5. (a) Relay voltage: In red portion of DC VOLTAGE meter.

Section	Action required	Reference standard
O-1032/PRC-47	<p>each with 110 volts, 400-Hz primary power source.</p> <ol style="list-style-type: none"> 1. Perform initial settings and adjustments. 2. Record output of 3.0 MHz subassembly. 3. Record locked oscillator Q4 bandwidth, and 500-kHz amplifier output levels. 4. Record locked oscillator Q8 bandwidth, and 100-kHz amplifier output levels. 5. Record final oscillator frequency. 	<ol style="list-style-type: none"> (b) Filtered low voltage: In red portion of DC VOLTAGE meter; ripple less than 0.075 volt rms. (c) Regulated voltage: In red portion of DC VOLTAGE meter; ripple less than 0.01 volt rms Range of adjustment from 18.0 to 20.0 volts dc set at 19.0 +0.4 volts. (d) Filament voltage: 6.9 to 6.5 volts rms on ac voltmeter. <ol style="list-style-type: none"> 1. (a) At A6J2, read 17.6 ± 1.0 volts dc. (b) Read 35.0 ± 6.0 ma on the 20V CURRENT mater. 2. Not less than 0.3 volt rms 3. (a) Q4 stable from 2.9 to 3.1 MHz. (b) Output at A6J3, 1.5 ± 0.2 volts rms (c) Output at A6J4, 1.5 ± 0.2 volts rms. 4. (a) Q8 stable from 2.9 to 3.1 MHz. (b) Output at A6J1, 1.5 ± 0.4 volts rms 5. At A6J3, output frequency is $5000,000.00 \pm 0.05$ Hz.
C-4311/PRC-47'	<ol style="list-style-type: none"> 1. Record pulse generator output. 2. Record 1.8- to 0.9-MHz. 3. Align and adjust crystal oscillator output. 4. Record output of 600 - 700-kHz filter. 	<ol style="list-style-type: none"> 1. (a) 100 kHz sinewave input is 1.81 ± 0.5 volts p*p and pulse width is 0.3 ± 0.1 us (b) 500 kHz input is 1.5 volts p-p (c) 1-MHz pulse output is 6.0 ± 2.5 volts p-p and fall tune is 0.1 ± 0.03 us. (d) Adjust capacitor C15 for minimum ripple on 1. MHz pulse. 2. Output volts at 1.8 - 0.9 MHz test point must not be less than: At 1.8 MHz, 2.3 volts p-p. At 1.7 MHz, 3.4 volts p-p. At 1.6 MHz, 4.3 volts p-p. At 1.5 MHz, 3.4 volts p-p. At 1.4 MHz, 2.8 volts p-p. At 1.3 MHz, 2.6 volts p p. At 1.2 MHz, 2.8 volts p-p. At 1.1 MHz, 3.6 volts p-p. At 1.0 MHz, 3.3 volts p-p. At 0.9 MHz, 3.3 volts p-p. 3. (a) Set output of Q21 to $3.707 \text{ MHz} \pm 1.0$ Hz. (b) Set output at A7J1 with S2 at 00 for each position of bandswitch S1 within ± 1 Hz: S1 at 0, 700.0 kHz S1 at 1, 699.0 kHz S1 at 2, 698.0 kHz S1 at 3, 697.0 kHz S1 at 4, 696.0 kHz S1 at 5, 695.0 kHz S1 at 6, 694.0 kHz S1 at 7, 693.0 kHz S1 at 8, 692.0 kHz S1 at 9, 691.0 kHz (c) Set output at A7J1 with S1 at 0 for each position of bandswitch S2 within ± 1 Hz: S2 at 1, 690.0 kHz S2 at 2, 680.0 kHz S2 at 3, 670.0 kHz S2 at 4, 660.0 kHz S2 at 6, 650.0 kHz S2 at 6, 640.0 kHz S2 at 7, 630.0 kHz S2 at 8, 620.0 kHz S2 at 9, 610.0 kHz 4. At A7J1, 0.9 to 1.3 volts pep, at each setting of S1 and S2.

Section	Action required	Reference standard
	5. Record output of 560 - 750-kHz filter. 6. Record frequency discriminator operation. 7. Adjust error voltages. 8. Verify successful antilock circuit operation. 9. Record SMO mixer output.	5. At A7J4, from 575- to 725-kHz, 0.6 to 1.0 volt pep; at 650 and 775 kHz, 0.7 volts p-p. maximum, and at 500 and 800 kHz, 0.2 volts pep maximum. 6. (a) At A7J5, not less than 4.0 volts dc from 650 to 700 kHz; A7J6 not more than 1.5 volts for same frequencies. At A7J5, not more than 1.6 volts dc from 700 to 750 kHz; A7J6 not less than 4.0 volts for same frequencies. (b) At A7J5, not less than 4.0 volts dc from 600 to 650 kHz; A7J6 not more than 1.5 volts for same frequencies. At A7J5, not more than 1.5 volts dc from 660 to 700 kHz; A7J6 not less than 4.0 volts for same frequencies. (c) At A7J5, not less than 4.0 volts dc from 560 to 600 kHz; A7J6 not more than 1.5 volts for same frequencies. At A7J5, not more than 1.5 volts dc from 600 to 650 kHz; A7J6 not less than 4.0 volts for same frequencies. 7. Select R144 to provide balanced 10 kHz modulation levels at the output circuits of Q9 and Q12. 8. ANTI-LOCK lamp operates satisfactory and A7J4 reads 1.05 volts pep. 9. At A7J4, 1.5 ± 0.4 volts pep throughout tuning range of equipment.

Section II. PERFORMANCE TESTS

6-9. General

This section contains the tests and performance data required to determine whether the repaired equipment meets the original performance requirements established for Radio Set AN/PRC-47.

6-10. Audio Frequency Amplifier AM-3506/PRC-47 (A8A1)

(Fig. 7-15)

a. Test Equipment and Material.

- (1) Audio Oscillator TS-382/U
- (2) Distortion Analyzer TS-723/U
- (3) Frequency Counter AN/URM-79/U
- (4) Loudspeaker LS-166/U (or Headset H233)

from AN /PRC -47

- (5) Multimeter ME-26A/U
- (6) Oscilloscope AN/USM-50
- (7) Output Meter TS-585/U
- (8) Power Supply (24 volts dc!, Harrison 6202B, or equal
- (9) Power Supply (-7 volts dc), Harrison 6203B or equal
- (10) Test fixture for AM-3506/PRC-47 (fig. 6-4)
- (11) Voltmeter ME-30A/U

b. Test Conditions and Equipment Connections.

CAUTION

Before connecting the power supplies to the test fixture, set their output voltages to 24.0 ± 2.0 volts and -7.0 ± 0.5 volts respectively. Then return the power on-off switch to off until instructed to apply primary power to them.

(1) Connect the audio oscillator, frequency counter, output meter and the two power supplies to the test fixture as shown in figure 6-11. (The connections for the remaining test equipment are detailed in the appropriate procedural steps below.

(2) Remove the dust cover from the module, set all potentiometers to mid-range (full turns from either end), and carefully insert the module into connector J1 on the test fixture.

(3) Apply primary power to all test equipment and turn on the power control switch of each unit. Immediately adjust the output of the 24 volts power supply to 24.0 ± 0.5 volts dc and then place the POWER switch of the test fixture to ON.

(4) Place the +20 V - +24 V switch to the +20 V position and observe that the MODULE CURRENT meter reads approximately 25 ma. Place the switch to +24 V and note the MODULE CURRENT indication is approximately 55 ma.

(5) Adjust the output of the -7 volts power supply using the SIDETONE GATE TEST jack (J3) and the SIDETONE GATE ADJUST control on the test fixture. The reading at J3 must be set to -7.0 ± 0.2 volts dc. Then place the power control switch on the -7 volts power supply to off.

(6) Permit the test equipment and the module to stabilize for at least 5 minutes before beginning the following procedures.

(7) Set the IMPEDANCE switch on the output meter to 300 OHMS, and adjust the meter multiplier for 5000 milliwatts full scale.

NOTE

Perform the initial adjustments and each of the following tests in the order listed to avoid erroneous test results or maladjustment of the module gain settings.

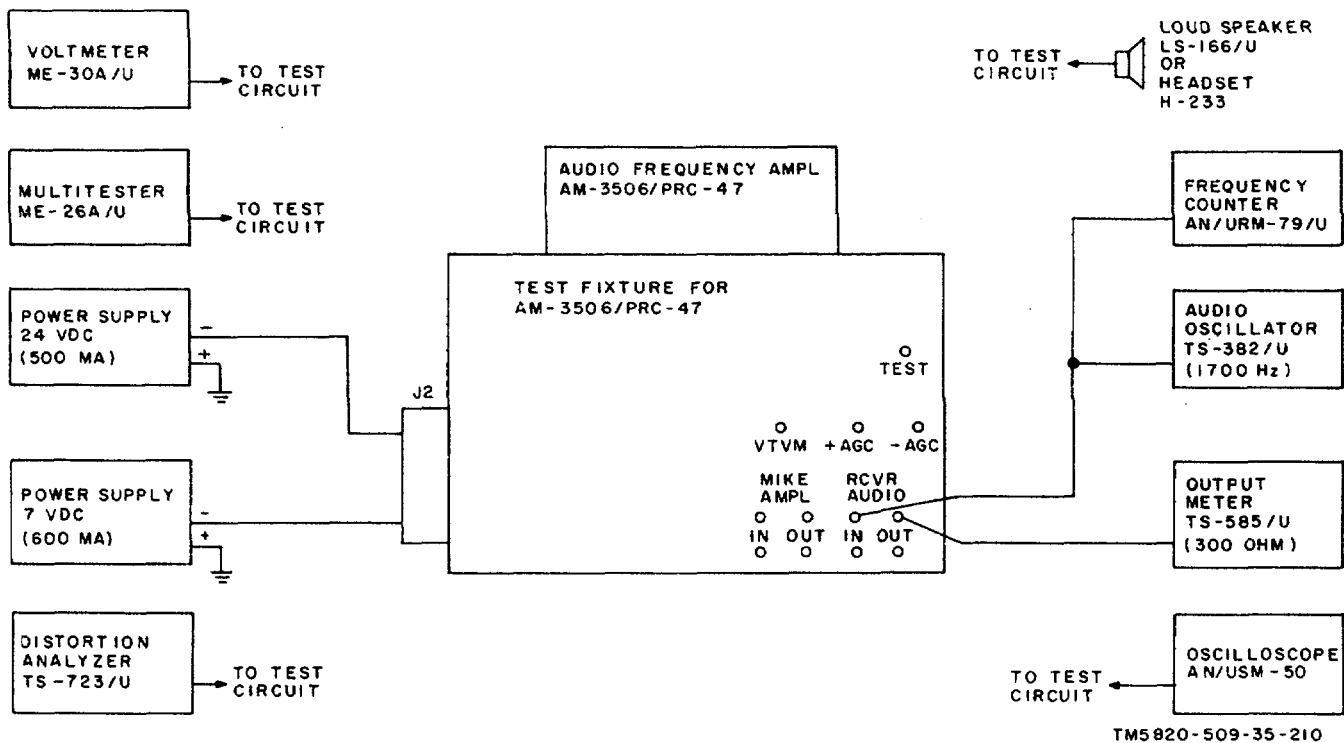

Figure 6-11. Audio Frequency Amplifier AM-3506/PRC-47 (A8A 7) Performance Tests, Initial Test Equipment Connections

c. Initial Settings and Adjustments.

(1) Set the audio oscillator output frequency to 1700 Hz and adjust the output level to 0.1 volt rms at RCVR AUDIO IN jacks (38 and J14).

(2) Observe the output meter and adjust receiver gain control R54 (fig. 3-94) until the meter reads 1.0 watt output (18.0 volts rms) at RCVR AUDIO OUT jacks (J7 and J13).

(3) Move the audio oscillator and the frequency counter to MIKE AMPL IN jacks (J5 and J11). reset the output level of the audio oscillator to 0.1 volt rms at 1700 Hz, if necessary.

(4) Connect the oscilloscope to MIKE AMPL OUT jacks (J6 and J12). Place the PTT switch of the test fixture to ON and adjust microphone amplifier gain control R27 (fig- 3-94) until a deflection of 3.5 volts peak-to-peak is observed on the oscilloscope.

(5) Reduce the output level of the audio oscillator to 0. Reset it to 0.010 ± 0.002 volt rms at MIKE AMPL IN jacks (J5 and J11) and adjust potentiometer R40 (fig. 3-94) until the VOX ON lamp (DS2) on the test fixture lights

(6) Move the oscilloscope input to RCVR AUDIO OUT jacks (J7 and J13). Energize the -7 volts dc power supply and reset SIDETONE GATE ADJUST control for -7.1 ± 0.1 volts dc at SIDETONE GATE TEST jack (J3), if necessary. Increase the output level of the audio oscillator to 0.1 volt rms at 1700 Hz.

(7) Adjust potentiometer R46 (fig. 3-94) until an oscilloscope deflection of 20 volts peak-to-peak is observed. Be sure that the waveshape is symmetrical (not clipped).

d. Maximum Output Levels, Receive Mode.

(1) Turn off the -7 volts dc power supply by

placing SIDETONE GATE ADJUST control to OFF. Move the audio oscillator and frequency counter to RCVR AUDIO IN jacks (J8 and J14). Slowly increase the level of the 1700 Hz tone until clipping is noted on the oscilloscope display.

(2) Measure the level at RCVR AUDIO OUT jacks (J7 and J13), using the output meter. The reading must not be less than 1 watt in 300 ohms (18 volts rms).

(3) Measure the voltage at +AGC jack (J10) with the multimeter. The reading must not be less than +14.0 volts dc.

(4) Measure the voltage at -AGC jack (J9) with the multimeter. The reading must be more negative than -5.5 volts dc.

e. Frequency Response and Distorsion, Receive Mode.

(1) Connect the distortion analyzer to RCVR AUDIO OUT jacks (J7 and J13) together with the output meter.

(2) Set the audio oscillator output frequency to 300 Hz and adjust the level at RCVR AUDIO IN jacks (J8 and J14) to 0.1 volt rms.

(3) Record the audio output (in dB) and the harmonic distortion (in %) that are present at RCVR AUDIO OUT jacks (J7 and J13). Record the +AGC voltage at J10 and the -AGC voltage at J9.

(4) Repeat steps (2) and (3) with the oscillator output frequency set to 1000 1700 and 3000 Hz.

NOTE

Be sure that the audio level at RCVR AUDIO IN jacks (J8 and J14) are maintained at 0.1 volt when the test frequency is adjusted.

(5) The frequency response shall not vary more than ± 3 dB from the value recorded at 1700 Hz.

(6) The harmonic distortion shall not exceed 8 % at any frequency.

(7) The +AGC voltage shall not be less than +7.0 volts dc at any frequency.

(8) The -AGC voltage must be more negative than -3.0 volts dc at any frequency.

f. AVC Signal Gate Operation, Receive Mode.

(1) Set the SIDETONE GATE ADJUST control to obtain 7.0 + 0.1 volts at SIDETONE GATE TEST jack (J3).

(2) Connect the audio oscillator and frequency counter to RCVR AUDIO IN jacks (J8 and J14), and adjust the output level to 0.1 volt at 1700 Hz.

(3) Note that the voltage at +AGC jack (J10) decreases to not more than 0.5 volts dc and the VOX ON lamp (DS2) lights when the KEY switch is placed ON.

NOTE

If the VOX ON lamp fails to light, adjust R40 (and R27, in extreme cases) until it lights.

(4) Return the KEY switch to OFF and place the SIDETONE GATE ADJUST control to OFF.

g. Harmonic Distortion and Frequency Response, Transmit Mode.

(1) Move the audio oscillator and frequency counter to MIKE AMPL IN jacks (J5 and J11) and adjust the oscillator output frequency to 1700 Hz.

(2) Place the PTT switch to ON and observe the waveform at MIKE AMPL OUT jacks (J6 and J12) with the oscilloscope. Increase the level of the audio oscillator output until clipping occurs on the waveform. Reduce the output of the audio oscillator until the clipping disappears.

(3) The voltage measured at MIKE AMPL IN jacks (J5 and J11) must not exceed 0.015 volt rms.

(4) Maintain the level measured in step (3), and record the frequency response and harmonic distortion at 300, 1000, 1700 and 3000 Hz.

(5) The frequency response shall not vary more than ± 2.5 dB from the value recorded at 1700 Hz.

(6) The harmonic distortion shall not exceed 5 % at any frequency.

h. Frequency Response at Nominal Output, Transmit Mode.

(1) Connect the audio oscillator and frequency counter to MIKE AMPL IN jacks (J5 and J11) and adjust the output level to 0.1 volt rms at 1700 Hz.

(2) Maintain this output level and measure the frequency response at 300, 1000, 1700, and 3000 Hz.

(3) The frequency response shall not vary more than +2.0 dB from the value measured at 1700 Hz.

i. CW Oscillator Operation Test.

(1) Disconnect the audio oscillator from the test fixture. Connect the oscilloscope, frequency counter, and loudspeaker (or headset) to MIKE AMPL OUT jacks (J6 and J12). Place the PTT switch to OFF.

(2) Place the KEY switch on the test fixture to ON and record the voltage at MIKE AMPL OUT jacks (J6 and J12). The output voltage shall not be less than 3.5 volts peak-to-peak.

(3) Record the output frequency at jacks J6

and J12. The cw oscillator output frequency shall be 800 ± 50 Hz.

(4) Operate the KEY switch between the MOM ON and OFF positions and observe the waveshape on the oscilloscope and listen to the output tone in the loudspeaker. The tone must be free from chirps and clicks, and the waveform shall display no sharp transients.

(5) When the KEY switch is held ON, the VOX ON lamp lights.

6-11. Amplifier-Modulator AM-3507/PRC-47 (A8A2)

(fig. 7-10)

a. Test Equipment and Material.

- (1) Audio Oscillator TS-382/U
- (2) Converter (for spectrum analyzer), Hewlett-Packard K15-8551B
- (3) Distortion Analyzer TS-723/U
- (4) Frequency Counter AN /URM -79/U
- (5) Multimeter ME-26A/U
- (6) Oscilloscope AN/USM-50
- (7) Power Supply (24 volts dc), Harrison 6202B, or equal

(8) Power Supply (-110 volts dc), Harrison 6207B, or equal

- (9) Resistance Decade Box MX-3991/V
- (10) Signal Generator SG-103/URM-25F
- (11) Spectrum Analyzer AN/UPM-110
- (12) Test fixture for AM-3507/PRC-47 (fig. 6-

5)

(13) Voltmeter ME 30A/U

b. Test Conditions and Equipment Connections.

CAUTION

Before connecting the power supplies to the test fixture, set their output voltages to 26.0 ± 2.0 volts and -110 ± 5 volts respectively. Then return the power on-off switches to the off position until instructed to apply primary power to them.

(1) Connect the test instruments to the test fixture as shown in figure 6-12. (The connections for the remaining test equipment are detailed in the appropriate procedural steps below.)

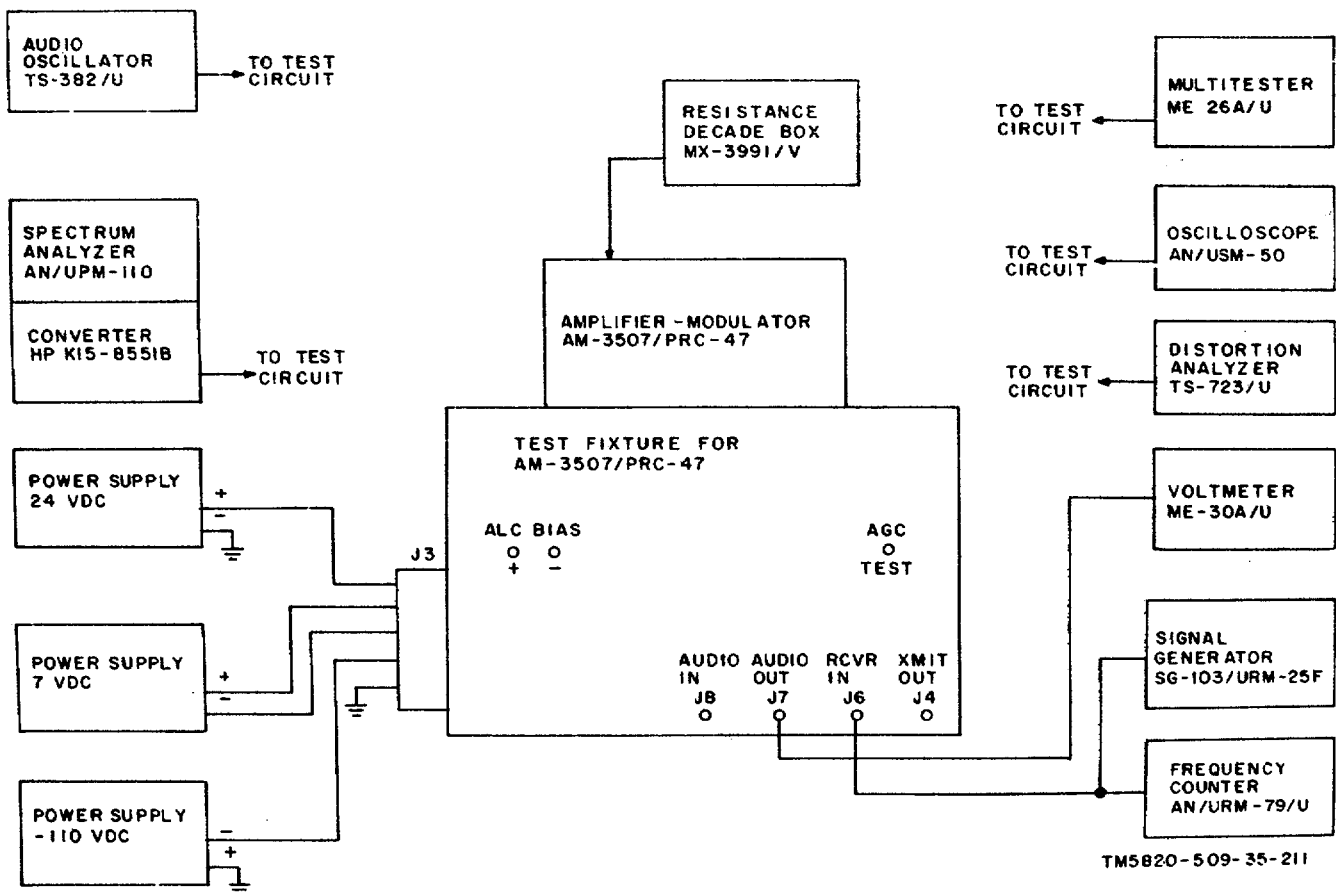

TM5820-509-35-211

Figure 6-12. Amplifier-Modulator AM 3507/PRC-47 (A8A2), Performance Tests, Initial Test Equipment Connections.

(2) Remove the dust cover from the module, and plug it into the test fixture.

(3) Apply primary power to all test instruments and turn on each of the units. Immediately adjust the output of the 24 volts power supply to 20.0 ± 1.0 volts, the output of the 7 volts power supply to 6.0 ± 0.5 volts, and the output of the 110 volts power supply to -110 ± 3.5 volts dc.

(4) Place the POWER switch on the test fixture to ON, the AGC and ALC BIAS switches to OFF, the XMIT-RCVR switch to RCVR and the METER RANGE switch to 200. Permit the test equipment and the module to stabilize for at least 5 minutes before beginning the following procedures.

NOTE:

Perform the initial adjustments and each of the following tests in the order listed to avoid erroneous test results or maladjustment of the module alignment.

e. Initial Settings and Adjustments.

(1) Set the signal generator to 498.3 kHz (cw operation) and adjust the output level to 100 microvolts at RCVR IN jack (J6) Connect the voltmeter to AUDIO OUT jack (J7) and adjust C15, C17, L6, L7, and T3 for maximum output. Record this output reading in dB for reference below.

(2) Slowly vary the signal generator output frequency between 497.0 and 499.7 kHz and observe the point at which minimum output occurs. The minimum audio output level at J7 shall not be more than 3 dB below the reading recorded in step (1) above.

NOTE

If the minimum audio output level is greater than 3 dB below the maximum output level observed in step (1), set the signal generator to this frequency. Then readjust C15 and C17 to increase the output until it meets the performance standard. Repeat steps (1) and (2) to verify.

(3) Place the XMIT-RCVR switch on the test fixture to XMIT (the AGC and the ALC BIAS switches remain OFF); connect the voltmeter and spectrum analyzer converter to the XMIT OUT jack.

(4) Connect the audio oscillator to AUDIO IN jack (J8) Set the output frequency to 2800 Hz and adjust the output level to 1.25 volts rms.

(5) Adjust transformer T2 (fig. 3-7) and inductor L4 to obtain a maximum indication on the voltmeter at XMIT OUT jack (J4).

(6) Set the audio oscillator output frequency to 1700 Hz and adjust the level at AUDIO IN jack (J8) to 1.25 volts rms. If the voltmeter reads 0.5 ± 0.1 volt rms at XMIT OUT jack (J8) continue to step (9) If not, perform steps (7) and (8)

(7) Connect the resistance decade box at the eyelets normally used to attach R14 (fig. 3-20), after removing R14. Set the selector knobs on the decade box to 3900 OHMS.

(8) Repeat step (6) and adjust the resistance settings of the-resistance decade box until the voltmeter reading specifies) is obtained. Select a suitable resistance and install it in the module at the eyelets from which the original R14 was removed.

NOTE

Repeat step (6) after installation of the replacement R14 to verify that proper output is indeed available at XMIT OUT jack (J4).

(9) Adjust capacitor C35 and potentiometer R5 on the module to minimize the carrier indication on the spectrum analyzer.

NOTE

If capacitor C35 is adjusted to either limit, select a new value for shunting capacitor C36 that permits an intermediate setting. Repeat step (9), if necessary.

d. Output, Receive.

(1) Place the XMIT-RCVR switch on the test fixture to RCVR (the AGC and ALC BIAS switches remain OFF).

(2) Disconnect the audio oscillator and the spectrum analyzer converter from the test fixture and connect the voltmeter to AUDIO OUT jack (J7)

(3) Connect the signal generator and frequency counter to RCVR IN jack (J6) and set the signal generator output frequency to 498.3 kHz.

(4) Adjust the output level of the signal generator until the voltmeter reads 0.1 volt rms; then move the voltmeter to RCVR IN jack (J6) and measure the output level of the signal generator. The level at J6 shall not be greater than 200 microvolts.

e. Distortion, Receive.

(1) The AGC and ALC BIAS switches remain OFF and the XMIT-RCVR switch remains in the RCVR position.

(2) Verify that the signal generator output frequency is 498.3 kHz and that the output is connected to RCVR IN jack (J6).

(3) Adjust the output level of the signal generator until the voltmeter reads 0.1 volt rms at AUDIO OUT jack (J7)

(4) Place the AGC switch to ON and set AGC ADJUST control for a voltmeter reading of 0.05 volt rms at AUDIO OUT jack (J7).

(5) Connect the distortion analyzer to AUDIO OUT jack (J7) and observe that the harmonic distortion does not exceed 5 %.

(6) Repeat steps (2) through (4) except adjust the signal generator output frequency to 497.0 kHz. Repeat with signal generator output frequency set to 499.7 kHz. The harmonic distortion observed shall not exceed 5 % at either frequency.

(7) Disconnect the distortion analyzer and connect the oscilloscope at AUDIO OUT jack (J7).

(8) Increase the output of the signal generator to 0.05 volt rms and vary the signal generator output frequency between 497 and 500 kHz.

(9) There shall be no spikes or ripple on the audio signal and no sudden increase in output level indicated on the oscilloscope trace.

f. Selectivity, Receive.

(1) Place the AGC and ALC BIAS switches to OFF and the XMIT-RCVR switch to RCVR. Verify that the voltmeter is connected to AUDIO OUT jack (J7)

(2) Verify that the signal generator output frequency is set to 498.3 kHz and that the voltmeter reads 0.1 volt rms.

(3) Move the voltmeter to RCVR IN jack (J6) and increase the signal generator output level by 60 dB. Return the voltmeter to AUDIO OUT jack (J7) and vary the signal generator output frequency below 498.3 kHz until the voltmeter again reads 0.1 volt rms. Record the signal generator frequency.

(4) Adjust the signal generator output frequency above 498.3 kHz until the voltmeter again reads 0.1 volt rms. Record the signal generator output frequency. The difference between the frequency obtained in step (4) and the frequency obtained in step (3) shall not be greater than 6.0 kHz.

g. Frequency Response, Receive.

(1) Reduce the signal generator output and reset the output frequency to 498.3 kHz. Adjust the output level of the signal generator until the voltmeter reads 0.1 volt rms.

(2) Adjust the signal generator to 497.0 kHz and record the output (in dB) with reference to 0 dB for the voltmeter reading in step (1).

(3) Adjust the signal generator to 499.7 kHz

and record the output (in dB) with reference to 0 dB for the voltmeter reading in step (1). The output level shall not increase more than 3 dB above the reference in step (1), nor decrease more than 4 dB below that reference at 497.0 and 499.7 kHz.

6-12. Signal Data Translator CV-1377A/PRC-47 (A8A3)

(fig. 7-11)

a. Test Equipment and Material.

- (1) Gauge, overtravel 0.041-in. (fig. 6-2)
- (2) Gauge, plug (depth) (fig. 6-1)
- (3) Gauge, thickness 0.02 to 0.020-in. (FSN 5210-031- 1504)
- (4) Frequency Counter AN/URM-78/U
- (5) Multimeter ME-26A/U
- (6) Oscilloscope AN/USM-50
- (7) Power Supply (24 volts dc) Harrison 6202B (2 required)
- (8) Power Supply 1110 volts dc), Harrison 6207 B.
- (9) Receiver R-1433/UR 6-6).
- (10) Signal Generator SG-103/URM-25F.
- (11) Test Fixture for CV-1377A/PRC-47 (fig. 6-7).
- (12) Test Fixture, indexing (fig. 6-7).
- (13) Voltmeter ME-30A/U.

b. Test Conditions and Equipment Connections

CAUTION

Before connecting the power supplies to the test fixture, set their output voltages to 14.0 ± 2.0 volts, 26.5 ± 2.0 volts, and -110 ± 5 volts dc respectively. Then return the power on-off switches to the off position until instructed to apply primary power to them.

(1) connect the test instruments to the test fixture as shown in figure 6-13. (The connections for the remaining test equipment are detailed in the appropriate procedural step below.)

(2) Before placing the CV-1377A/PRC-47 into the test fixture, remove the top and bottom covers from the module. Perform the mechanical alignment procedures (step c) if the slug rack or its associated inductors have been replaced.

(3) Place all switches on the test fixture to OFF and all of the controls to zero.

(4) Apply power to all test equipment and turn on each of them. Place the test fixture POWER ON-OFF switch to ON and reset the output of the power supplies to 19.0 ± 1.0 volts dc at connector J 1-3, 26.5 ± 1.5 volts dc at connector J 1-4, and -110 ± 3.5 volts dc at connector J5-E.

(5) Measure the output voltage at connector J3-1 and set potentiometer R6 of the test set to obtain- 35 ± 1.0 volts dc.

(6) Place the AVC ON-OFF switch of the test fixture to ON and measure the output voltage at connector J3-4. Set potentiometer R8 on the test fixture to obtain-2.2 volts dc.

(7) After performing the mechanical alignment procedures of step c, replace the bottom cover on the CV-1377A/PRC-47, attach the indexing fixture to the drive coupling end of the module with the three knurled thumbscrews.

Place the test fixture POWER ON-OFF switch to OFF and install the module in the test fixture.

(8) Return the test fixture POWER ON-OFF switch to ON and permit the module and the test equipment to stabilize for at least 5 minutes before performing the remaining procedures.

NOTE

If the mechanical alignment procedure was performed in (7) above, proceed directly to step d and perform the remaining procedures in the order listed.

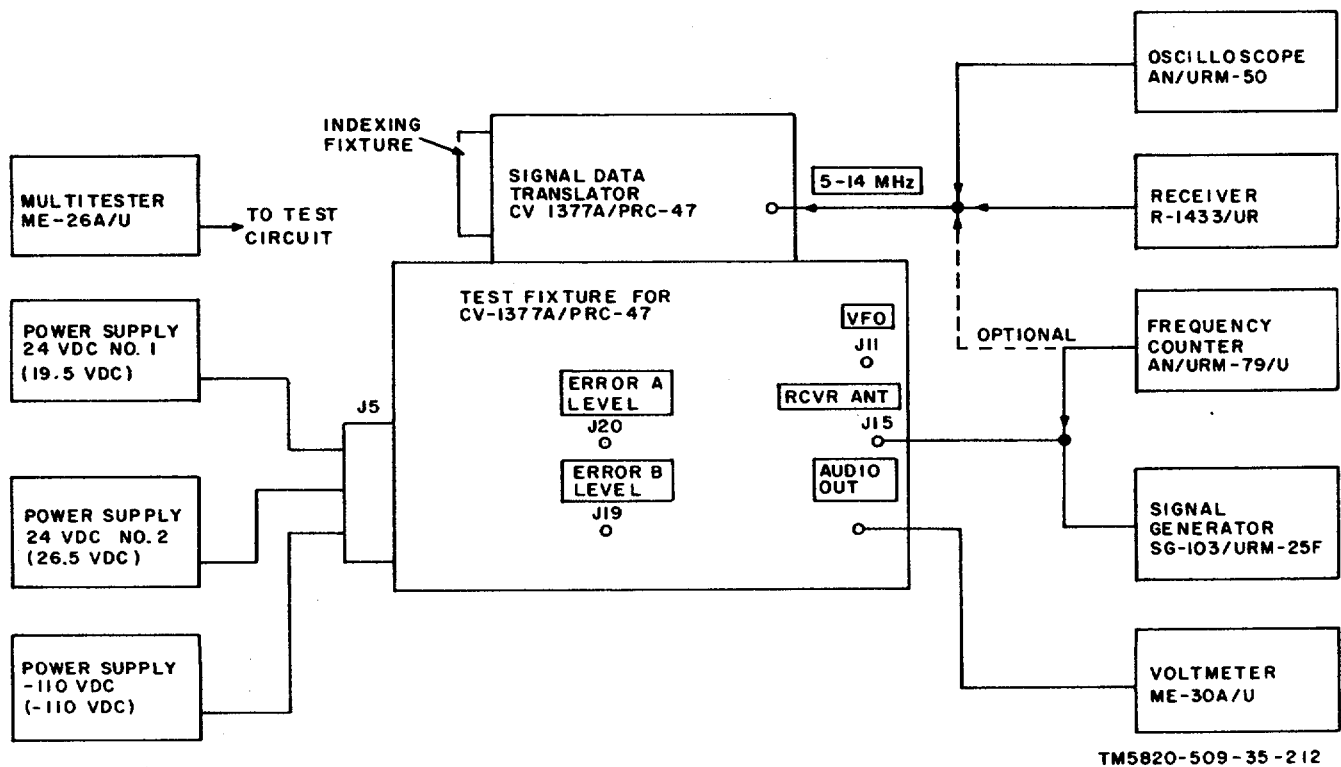

TM5820-509-35-212

Figure 6-13. Signal Data Translator CV-1377A/PRC - 47 (A8A3), Performance Tests, Initial Test Equipment Connections.

c. *Mechanical Alignment.* This procedure is performed with the module disconnected from the test fixture. The bottom cover must be loosened and removed to provide access to the inductor slugs. Refer to figures 3-41, 3-96 through 3-98, and 3-105 for the location of adjustments referred to in these procedures.

(1) Using multimeter ME-26A/U, check the internal resistance between connector P3-3 and ground, and between P3-4 and ground; each reading shall be $100 \text{ ohms} \pm 10 \%$

(2) Attach the 0.041" overtravel tool to the slug rack. With the control on the indexing fixture set for 000 (slugs fully inserted in their respective coils), adjust L1, L2, and L3 (fig. 3-96) to a depth of 7/32-inch

from the bottom of the coil form (second ring on plug gage (fig. 6-1)).

(3) Set the slug of coil L4 to a depth of 5/32inch from the bottom of the coil form (first ring on plug gage), and set L5 slug to a depth of 1/4-inch from the bottom of the coil form (third ring on the plug gage). Set the slug of coil L145 to a depth of 9/32 inch (fourth ring on the plug gage).

(4) Remove the 0.041" overtravel tool from the slug rack, install the bottom cover of the module, and install the module in the test fixture.

NOTE

Return to paragraph 6-12 b (7) and

continue the procedures after performing the remaining initial setup instructions.

d. 5- to 14- MHz Ringer Circuit Alignment.

(1) Connect the oscilloscope and receiver (or frequency counter) and the multimeter rf probe to the 5-14 MHz tip jack at the right side of the upper shelf of the test fixture.

(2) Set the switch on the indexing fixture (fig. 6-7) to 2, and the slug rack control to 000 position.

(3) On the test fixture, place the POWER ON-OFF switch to ON, the FUNCTION SEL switch to RCVR, the AVC switch to ON, the LOOP SEL switch to CLOSED, and OSC CONT switches to 0 and 00.

(4) Adjust capacitor C248 (fig. 3-97) to provide a 5.000 MHz reading on the receiver (or frequency counter) Set the oscilloscope sweep rate to 1.0 microseconds/cm. and readjust capacitor C248 for minimum 1-MHz ripple (amplitude modulation) on the oscilloscope wavetrain. The remaining 5.0 MHz wavetrain amplitude shall be not less than 0.9 volts peak-to-peak.

(5) Rotate the switch on the indexing fixture to 3 and set the receiver to 6.0 MHz.

(6) Adjust capacitor C250 to provide a 6.000 M Hz reading on the receiver (or frequency counter). Readjust capacitor C250 for minimum 1-MHz ripple on the oscilloscope wavetrain. The remaining 6.0 MHz wavetrain amplitude shall not be less than 0.9 volts peak-to-peak.

(7) Rotate the switch on the indexing fixture to 4 and set the receiver to 7.0 MHz.

(8) Adjust capacitor C252 to provide a 7.000 MHz reading on the receiver (or frequency counter). Readjust capacitor C252 for minimum 1-MHz ripple on the oscilloscope wavetrain. The remaining 7.0 MHz wavetrain amplitude shall not be less than 0.9 volt peak-to-peak.

(9) Rotate the switch on the indexing fixture to 5 and set the receiver to 8.0 MHz.

(10) Adjust capacitor C254 to provide an 8.000 MHz reading on the receiver (or frequency counter). Readjust capacitor C254 for minimum 1-MHz ripple on the oscilloscope wavetrain. The remaining 8.0 MHz wavetrain amplitude shall not be less than 0.9 volt peak-to-peak.

(11) Rotate the switch on the indexing fixture to 6 and set the receiver to 9.0 MHz.

(12) Adjust capacitor C256 to provide a 9.000 MHz reading on the receiver (or frequency counter). Readjust capacitor C256 for minimum 1-MHz ripple on the oscilloscope wavetrain. The remaining 9.0 MHz wavetrain amplitude shall not be less than 0.9 volt peak-to-peak.

(13) Rotate the switch on the indexing fixture to 7 and set the receiver to 10.0 MHz.

(14) Adjust capacitor C258 to provide a 10.000 MHz reading on the receiver (or frequency counter). Readjust capacitor C258 for minimum 1-MHz ripple on the oscilloscope wavetrain. The remaining 10.0 MHz wavetrain amplitude shall not be less than 0.9 volt peak-to-peak.

(15) Rotate the switch on the indexing fixture to 8 and set the receiver to 11.0 M Hz.

(16) Adjust capacitor C260 to provide an 11.000 MHz reading on the receiver (or frequency counter). Readjust capacitor C260 for minimum 1-MHz ripple on the oscilloscope wavetrain. The remaining 11.0 MHz wavetrain amplitude shall not be less than 0.9 volt peak-to-peak.

(17) Rotate the switch on the indexing fissure to 9 and set the receiver to 12.0 MHz.

(18) Adjust capacitor C262 to provide a 12.000 MHz reading on the receiver (or frequency counter). Readjust capacitor C262 for minimum 1-MHz ripple on the oscilloscope wavetrain. The remaining 12.0 MHz wavetrain amplitude shall not be less than 0.9 volt peak-to-peak.

(19) Rotate the switch on the indexing fixture to 10 and set the receiver to 13.0 MHz.

(20) Adjust capacitor C264 to provide a 13.000 MHz reading on the receiver (or frequency counter). Readjust capacitor C264 for minimum 1-MHz ripple on the oscilloscope wavetrain. The remaining 13.0 MHz wavetrain amplitude shall not be less than 0.9 volt peak-to-peak.

(21) Rotate the switch on the indexing fixture to 11 and set the receiver to 14.0 M Hz.

(22) Adjust capacitor C266 to provide a 14.000 MHz reading on the receiver (or frequency counter). Readjust capacitor C266 for minimum 1-MHz ripple on the oscilloscope wavetrain. The remaining 14.0 MHz wavetrain amplitude shall not be less than 0.9 volt peak-to-peak.

e. Oscillator Output Test

(1) Rotate the indexing fixture switch (fig. 67) to 2, and set the slug rack control to 500.

(2) On the test fixture, set the LOOP SEL switch to CLOSED, place OSC CONTROL switch S1 to 0, and set OSC CONTROL switch S2 to 50.

(3) Connect the multimeter rf probe to the test fixture VFO jack.

(4) Read the multimeter; then rotate the switch on the indexing fixture to 3, and the OSC CONTROL switch S1 to 1 and read the multimeter again. Continue the simultaneous advancement of the indexing fixture switch and the OSC CONTROL switch S1 throughout their range. The multimeter reading shall not be less than 1.0 volt at any band position.

f. Oscillator Alignment and Tracking Adjustment.

(1) On the test fixture, place the POWER ON-OFF switch to OFF and the LOOP SEL switch to OPEN.

(2) Remove the module from the test fixture and adjust capacitor C344 (fig. 3-98) to its mechanical midpoint.

(3) Return the test fixture POWER ON-OFF switch to ON and adjust ERROR A ADJ and ERROR B ADJ controls to provide 1.0 ± 0.05 volt dc at test points J19 and J20. Record the voltage at each of these test points.

(4) Again place the test fixture POWER ON-OFF switch to OFF and install the module in the test fixture.

(5) With the multimeter connected to J19, close the test fixture POWER ON-OFF switch to ON and note that the ERROR B LEVEL does not change more than ± 0.1 volt from the reading recorded in step (3).

(6) Move the multimeter to J20 and observe that ERROR A LEVEL does not change more than ± 0.1 volt from the reading recorded in step (3).

(7) Adjust the receiver to 2.500 MHz and loosely couple the receiver antenna to the VFO jack on the test fixture. (The frequency counter may be connected to the test fixture VFO jack as an alternate method.)

(8) On the indexing fixture (fig. 6-7), set the switch to 2, and rotate the slug rack control to 000 position.

(9) Adjust inductor L135 (fig. 3-105) until the vfo output is $2,500 \pm 1$ kHz.

(10) Rotate the slug rack control on the indexing fixture to the 999 position and adjust inductor L125 (fig. 3-96) until the vfo output is $3,500 \pm 1$ kHz.

(11) Repeat steps (9) and (10) until both frequency settings are within the ± 1 kHz limit specified.

(12) On the indexing fixture, set the switch to 3 and rotate the slug rack control to 000. Adjust inductor L136 (fig. 3-105) until the vfo output is $3,500 \pm 1$ kHz.

(13) Rotate the slug rack control on the indexing fixture to the 999 position and adjust inductor L126 (fig. 3-96) until the vfo output is $4,500 \pm 1$ kHz

(14) Repeat steps (12) and (13) until both frequency settings are within the ± 1 kHz limit specified.

(15) On the indexing fixture, set the switch to 4 and rotate the slug rack control to 000. Adjust inductor L137 (fig. 3-105) until the vfo output is $4,500 \pm 1$ kHz.

(16) Rotate the slug rack control on the indexing fixture to the 999 position and adjust inductor L127 (fig. 3-96) until the vfo output is $5,500 \pm 1$ kHz.

(17) Repeat steps (16) and (17) until both frequency settings are within the ± 1 kHz limit specified.

(18) On the indexing fixture, set the switch to 5 and rotate the slug rack control to 000. Adjust inductor L138 (fig. 3-96) until the vfo output is $5,500 \pm 1$ kHz.

(19) Rotate the slug rack control on the indexing fixture to the 999 position and adjust inductor L128 (fig. 3-105) until the vfo output is $6,500 \pm 1$ kHz.

(20) Repeat steps (18) and (19) until both frequency settings are within the ± 1 kHz limit specified.

(21) On the indexing fixture, set the switch to 6 and rotate the slug rack control to 000. Adjust inductor L139 (fig. 3-96) until the vfo output is $6,500 \pm 1$ kHz.

(22) Rotate the slug rack control on the indexing fixture to the 999 position and adjust inductor L129 (fig. 3-105) until the vfo output is $7,600 \pm 1$ kHz.

(23) Repeat steps (21) and (22) until both frequency settings are within the ± 1 kHz limit specified.

(24) On the indexing fixture, set the switch to 7 and rotate the slug rack control to 000. Adjust inductor L140 (fig. 3-96) until the vfo output is $7,500 \pm 1$ kHz.

(25) Rotate the slug rack control on the indexing fixture to the 999 position and adjust inductor L130 (fig. 3-105) until the vfo output is $8,600 \pm 1$ kHz.

(26) Repeat steps (24) and (25) until both frequency settings are within the ± 1 kHz limit specified.

(27) On the indexing fixture, set the switch to 8 and rotate the slug rack control to 000. Adjust inductor L141 (fig. 3-96) until the vfo output is $8,500 \pm 1$ kHz.

(28) Rotate the slug rack control on the indexing fixture to the 999 position and adjust inductor L131 (fig. 3-105) until the vfo output is $9,500 \pm 1$ kHz.

(29) Repeat steps (27) and (28) until both frequency settings are within the ± 1 kHz limit specified.

(30) On the indexing fixture, set the switch to 9 and rotate the slug rack control to 000. Adjust

inductor L142 (fig. 3-96) until the vfo output is $9,500 \pm 1$ kHz.

(31) Rotate the slug rack control on the indexing fixture to the 999 position and adjust inductor L132 (fig. 3-105) until the vfo output is $10,500 \pm 1$ kHz.

(32) Repeat steps (30) and (31) until both frequency settings are within the ± 1 kHz limit specified.

(33) On the indexing fixture, set the switch to 10 and rotate the slug rack control to 000. Adjust inductor L143 (fig. 3-105) until the vfo output is $10,500 \pm 1$ kHz.

(34) Rotate the slug rack control on the indexing fixture to the 999 position and adjust inductor L133 (fig. 3-96) until the vfo output is $11,500 \pm 1$ kHz.

(35) Repeat steps (33) and (34) until both frequency settings are within the ± 1 kHz limit specified.

(36) On the indexing fixture, set the switch to 11 and rotate the slug rack control to 000. Adjust inductor L144 (fig. 3-105) until the vfo output is $11,500 \pm 1$ kHz.

(37) Rotate the slug rack control on the indexing fixture to the 999 position and adjust inductor L134 (fig. 3-96) until the vfo output is $12,500 \pm 1$ kHz.

(38) Repeat steps (36) and (37) until both frequency settings are within the ± 1 kHz limit specified.

(39) Without further adjustment to the inductors mentioned above, record the oscillator output frequencies for each setting of the band switch and the slug rack control on the indexing fixture. The maximum allowable deviation from the desired oscillator output is ± 12 kHz within any one band.

NOTE

If the frequency deviates more than this amount from the desired value, tracking correction is necessary. If the majority of the bands is high (or low) at the 500 position of the slug rack control, adjust C344 (fig. 3-98). If C344 fails to compensate for tracking error, replace one or more of the capacitors (C299, C301, C303, C305, C307, C309, C311, C313, C315 or C317) in the shunt coil assemblies. The low frequency end of bands 3 through 11 (M Hz) can be raised or lowered to a maximum deviation of ± 8 kHz to assist in tracking at mid-band. Do not adjust the low -frequency end of the 2.0 M Hz band.

g. Rf Alignment, Receive Mode

(1) On the test fixture, place the FUNCTION SEL switch to RCVR, the LOOP SEL switch to CLOSED, and then place the POWER ON-OFF switch to ON. Set OSC CONTROL to 0 and 09.

(2) Rotate the switch on the indexing fixture (fig. 6-7) to 2 and set the slug rack control to the 000 position.

(3) Adjust the signal generator to 2.0 MHz, CW operation, and connect the RF OUTPUT jack to the RCVR ANT jack of the test fixture.

(4) Connect the voltmeter to the AUDIO OUT jack of the test fixture and adjust the signal generator output frequency and level controls until an indication is obtained on the voltmeter.

(5) Adjust inductors L7, L22, L37, and L52 (fig. 3-105) to obtain maximum voltmeter reading. Minimum limit is 0.04 volts rms.

NOTE

Adjust the output level of the signal generator and the voltmeter scale multiplier as required to reduce the possibility of limiting within the several modules.

(6) Rotate the switch of the indexing fixture to 3 and set the output of the signal generator to approximately 3.0 MHz. Adjust the output level and frequency of the signal generator until an indication is obtained on the voltmeter.

(7) Adjust inductors L8, L23, L38, and L53 (fig. 3-105) to obtain maximum voltmeter reading. Minimum limit is 0.04 volts rms.

(8) Rotate the switch of the indexing fixture to 4 and set the output of the signal generator to approximately 4.0 MHz. Adjust the output level and frequency of the signal generator until an indication is obtained on the voltmeter.

(9) Adjust inductors L9, L24, L39, and L54 (fig. 3-105) to obtain maximum voltmeter reading. Minimum limit is 0.04 volts rms.

(10) Rotate the switch of the indexing fixture to 5 and set the output of the signal generator to approximately 5.0 MHz. Adjust the output level and frequency of the signal generator until an indication is obtained on the voltmeter.

(11) Adjust inductors L10, L25, L40, and L55 (fig. 3-96) to obtain maximum voltmeter reading. Minimum limit is 0.04 volts rms.

(12) Rotate the switch of the indexing fixture to 6 and set the output of the signal generator to approximately 6.0 MHz. Adjust the output level and frequency of the signal generator until an indication is obtained on the voltmeter.

(13) Adjust inductors L11, L26, L41, and

L56 (fig. 3-96) to obtain maximum voltmeter reading. Minimum limit is 0.04 volts rms.

(14) Rotate the switch of the indexing fixture to 7 and set the output of the signal generator to approximately 7.0 MHz. Adjust the output level and frequency of the signal generator until an indication is obtained on the voltmeter.

(15) Adjust inductors L12, L27, L42, and L57 (fig. 3-96) to obtain maximum voltmeter reading. Minimum limit is 0.04 volts rms.

(16) Rotate the switch on the indexing fixture to 8 and set the output of the signal generator to approximately 8.0 MHz. Adjust the output level and frequency of the signal generator until an indication is obtained on the voltmeter.

(17) Adjust inductors L13, L28, L43, and L58 (fig. 3-96) to obtain maximum voltmeter reading. Minimum limit is 0.04 volts rms.

(18) Rotate the switch of the indexing fixture to 9 and set the output of the signal generator to approximately 9.0 MHz. Adjust the output level and frequency of the signal generator until an indication is obtained on the voltmeter.

(19) Adjust inductors L14, L29, L44, and L59 (fig. 3-96) to obtain maximum voltmeter reading. Minimum limit is 0.04 volts rms.

(20) Rotate the switch of the indexing fixture to 10 and set the output of the signal generator to approximately 10.0 MHz. Adjust the output level and frequency of the signal generator until an indication is obtained on the voltmeter.

(21) Adjust inductors L15, L30, L45, and L60 (fig. 3-105) to obtain maximum voltmeter reading. Minimum limit is 0.04 volts rms.

(22) Rotate the switch of the indexing fixture to 11 and set the output of the signal generator to approximately 11.0 MHz. Adjust the output level and frequency of the signal generator until an indication is obtained on the voltmeter.

(23) Adjust inductors L16, L31, L46 and L61 (fig. 3-105) to obtain maximum voltmeter reading. Minimum limit is 0.04 volts rms.

h. Rf Alignment, Transmit Mode.

(1) On the test fixture, place the FUNCTION SEL switch to XMIT, the LOOP SEL switch to CLOSED, then place the POWER ON-OFF switch to ON, and OSC CONTROL switches to 0 and 00.

(2) Rotate the switch on the indexing fixture (fig. 6-7) to 2 and set the slug rack control to the 000 position.

(3) On the top of the module, rotate the rf gain control (R148) to its clockwise stop.

(4) Adjust the signal generator to 500 kHz, CW operation, and connect the RF OUTPUT jack to 500 KHZ IN jack (J18) on the test fixture.

(5) Connect the rf probe of the multimeter to RF OUT jack (J13) on the test fixture and adjust inductor L67 (fig. 3-105) to obtain maximum output.

NOTE

Adjust the output level of the signal generator as required to limit the maximum indication on the multimeter to 80 volts rms.

(6) On the indexing fixture, rotate the slug rack control to the 999 position. On the test fixture set OSC CONTROL switches to 9 and 99; then adjust inductor L5 (fig. 3-96) for maximum output indication.

(7) Reset the slug rack control on the indexing fixture to the 000 position and set the OSC CONTROL switches to 0 and 00; then repeat steps (5) and (6) until further adjustment no longer increases the output level.

(8) Record the signal generator output level necessary to produce 80 volts rms at J13, as the indexing fixture is placed at the 000, 500, and 999 positions (set OSC CONTROL switches on the test fixture to identical values as the indexing fixture). The output level must remain between 30 and 300 millivolts at each setting across the band.

(9) On the indexing fixture set the switch to 3 and rotate the slug rack control to the 000 position. Set the OSC CONTROL switches on the test fixture to 0 and 00; then adjust inductor L68 (fig. 3-105) for maximum output voltage.

(10) Repeat step (8).

(11) On the indexing fixture, set the switch to 4 and rotate the slug rack control to its 000 position. Set the OSC CONTROL switches on the test fixture to 0 and 00; then adjust inductor L69 (fig. 3-105) for maximum output voltage.

(12) Repeat step (8).

(13) On the indexing fixture, set the switch to 5 and rotate the slug rack control to its 000 position. Set the OSC CONTROL switches on the test fixture to 0 and 00; then adjust inductor L70 (fig. 3-96) for maximum output voltage.

(14) Repeat step (8).

(15) On the indexing fixture, set the switch to 6 and rotate the slug rack control to its 000 position. Set the OSC CONTROL switches on the test fixture to 0 and 00; then adjust inductor L71 (fig. 3-96) for maximum output voltage.

(16) Repeat step (8).

(17) On the indexing fixture, set the switch to 7 and rotate the slug rack control to its 000 position. Set the OSC CONTROL switches on the test fixture to 0 and 00; then adjust inductor L72 (fig. 3-96) for maximum output voltage.

(18) Repeat step (8).

(19) On the indexing fixture, set the switch to 8 and rotate the slug rack control to its 000 position. Set the OSC CONTROL switches on the test fixture to 0 and 00; then adjust inductor L73 (fig. 3-96) for maximum output voltage.

(20) Repeat step (8).

(21) On the indexing fixture, set the switch to 9 and rotate the slug rack control to its 000 position. Set the OSC CONTROL switches on the test fixture to 0 and 00; then adjust inductor L74 (fig. 3-96) for maximum output voltage.

(22) Repeat step (8).

(23) On the indexing fixture, set the switch to 10 and rotate the slug rack control to its 000 position. Set the OSC CONTROL switches on the test fixture to 0 and 00; then adjust inductor L76 (fig. 3-105) for maximum output voltage.

(24) Repeat step (8).

(25) On the indexing fixture, set the switch to 11 and rotate the slug rack control to its 000 position. Set the OSC CONTROL switches on the test fixture to 0 and 00; then adjust inductor L76 (fig. 3-105) for maximum output voltage.

(26) Repeat step (8).

NOTE

Potentiometer R148 may be adjusted to compensate for out-of-tolerance operation. Care should be taken to recheck critical frequencies to assure that they remain in tolerance after this adjustment.

(27) Disconnect the signal generator from the 500 KHZ IN jack of the test fixture. Adjust potentiometer R150 (fig. 3-96) for minimum output voltage on the multimeter.

i. Oscillator Control Isolation Amplifier Test.

(1) Connect the multimeter rf probe to the test set VFO jack.

(2) On the test fixture, place the FUNCTION SEL switch to RCVR, the AVC switch to ON, the LOOP SEL switch to CLOSED, OSC CONTROL switch S1 to 0 and OSC CONTROL switch S2 to 00; then place the POWER ON-OFF switch to ON.

(3) Set the switch on the indexing fixture (fig. 6-7) to 2 and rotate the slug rack control to the 000 position.

(4) Record the output voltage at VFO jack. This voltage shall not be less than 1.0 volt rms.

(5) Set the switch on the indexing fixture to 11 and leave the slug rack control at the 000 position. On the test fixture, place the OSC CONTROL switch S1 to 9 and OSC CONTROL switch S2 to 00.

(6) Repeat step (4).

6-13. Power Supply PP-3518/PRC-47. (A8A5) (fig. 7-12)

a. Test Equipment and Material.

- (1) Ammeter, AC (0 to 5 amperes)
- (2) Ammeter, DC (0 to 1 ampere)
- (3) Ammeter, DC (0 to 15 amperes)
- (4) Oscilloscope AN/USM-50
- (5) Power Supply (24 volts dc), Harrison 6434B or equal
- (6) Multimeter ME-26A/U
- (7) Test fixture for PP-3518/PRC-47
- (8) Voltmeter ME-30A/U.

b. Test Conditions and Equipment Connections.

CAUTION

Before connecting the Harrison 6434B power supply to the test fixture, set its output voltage to 24.0 ± 2.0 volts dc. Return the power on-off switch of this power supply to off until instructed to apply primary power to it.

(1) Connect the ac primary power sources to the test set with the ac ammeter properly connected to the 115 volts ac 400 Hz mains. (See fig. 6-14.)

NOTE

Observe that the current transformer, if used, has the proper turns ratio for the ammeter.

WARNING

Never permit the secondary of the current transformer to remain open-circuited with power applied to the primary power source. Fatal voltages can exist across this winding.

(2) Connect the dc power supply to the test fixture with the 0 to 15 ampere dc ammeter connected to the positive (+) lead from this power supply. (See fig. 6-14.)

NOTE

If an ammeter shunt is required with the dc ammeter being used, be sure that the voltage drop and current rating match the dc ammeter.

(3) Connect the remainder of the test instruments to the test fixture as shown in figure 614.

(4) Remove the top cover from the PP-3518/PRC-47 power supply module to be tested, and install this module in the connector on top of the test fixture.

(5) On the test fixture, place the HV ON-OFF switch to OFF, the +23V ON-OFF switch to OFF, and the VOLTAGE SEL switch to

+19V. Then place the BLOWER ON-OFF switch to ON and set 115VAC ON-OFF switch to ON. Observe that the text fixture blower is running, and 115 VAC lamp is lit.

WARNING

Voltages to 1500 volts are present in the PP-3518/PRC-47 power supply module.

Personal injury or death can result. Be careful.

NOTE

Perform the initial adjustments and each of the following tests in the order listed to avoid erroneous test results or maladjustment of the control settings.

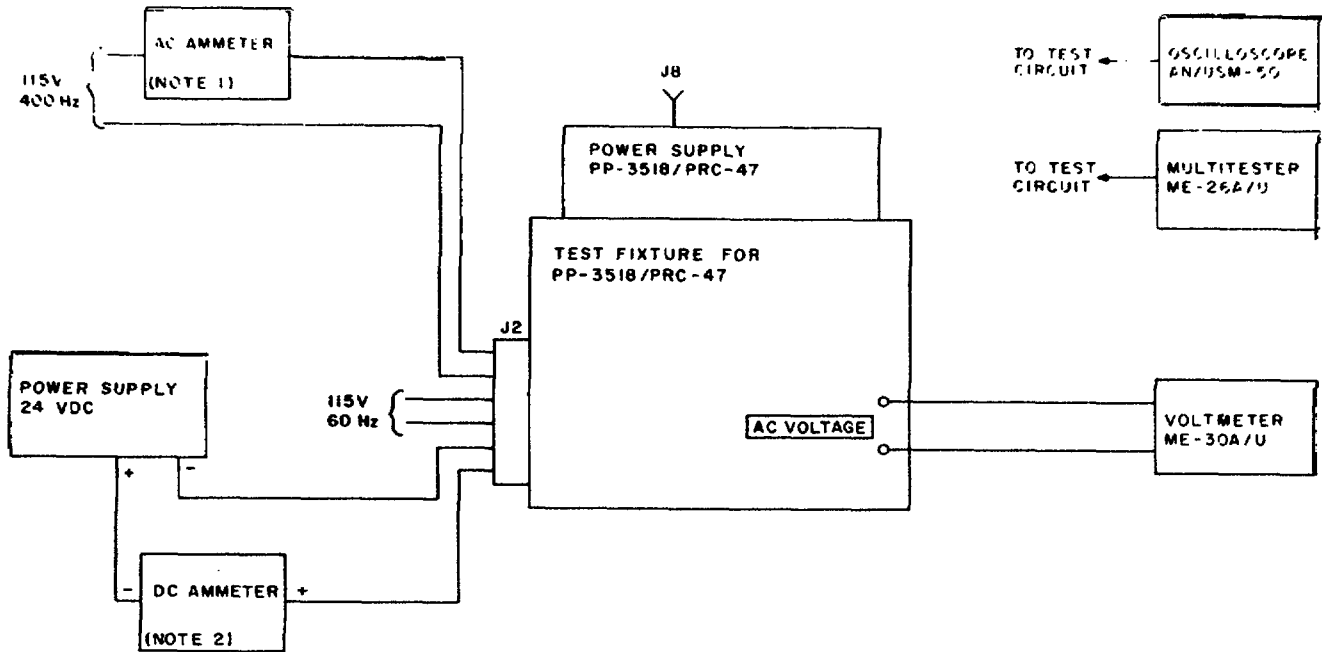

NOTES:

1. CONNECT TRANSFORMER-TYPE AC AMMETER AS FOLLOWS:

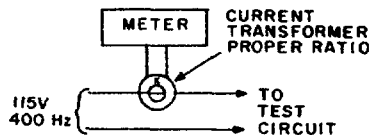

WARNING:
NEVER DISCONNECT THE CURRENT TRANSFORMER FROM THE METER WITH POWER APPLIED TO THE 115 VAC MAIN.

2. CONNECT SHUNT-TYPE DC AMMETER AS FOLLOWS:

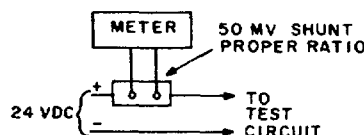

TM5820-509-35-213

Figure 6-14. Power Supply PP-3518/PRC-47 (A8A5), Performance Tests, Initial Test Equipment Connections.

c. Initial Settings and Adjustments.

(1) Rotate the VOLTAGE SEL switch to all positions and note that an indication is obtained on the DC VOLTAGE meter only at the +19V, +23V, and +26.5V positions. (Ignore the ac voltmeter at this time)

(2) Place the HV ON-OFF switch to ON and note that an indication is obtained on the DC VOLTAGE meter in all positions of the VOLTAGE SEL switch except FIL. The ac voltmeter indicates approximately 6.3 volts when VOLTAGE SEL is in the FIL position.

(3) Place the HV ON-OFF switch to OFF, return the VOLTAGE SEL switch on the test fixture to +19V position, and apply primary power to the Harrison 6434B power supply. Then place the test set +23V ON-OFF switch to ON

(4) Connect the multimeter to the output terminals of the Harrison 6434B power supply and adjust the terminal voltage to 23.0 ± 0.25

volts dc. Then move the multimeter dc lead to test jack J8 (fig. 3-11) on Power Supply PP-3518/PRC-47.

(6) Adjust potentiometer A5R22 (fig. 3-11) until the multimeter reads 19.0 ± 0.4 volts dc.

(6) Connect the multimeter negative (-) lead to test jack J2 (fig. 3-11) on Power Supply PP-3518/PRC-47.

(7) Adjust potentiometer A5R3 (fig. 3-11) until the multimeter reads -110 ± 5.5 volts dc.

(8) Connect the multimeter negative (-) lead to test jack J1 (fig. 3-11) on Power Supply PP-3518/PRC-47.

(9) Adjust potentiometer A5R4 (fig. 3-11) until the multimeter reads -32 ± 1.6 volts dc.

d. Performance Tests, 26.5-volts DC Primary Power Source. The tests listed in paragraphs e to o are to be conducted in the sequence shown after these initial conditions have been satisfied.

(1) Connect the test equipment to the test fixture as shown in figure 6-14 using the 0- to 15 ampere dc ammeter.

(2) Install Power Supply PP-3518/PRC-47 in the test fixture; then apply power to the Harrison 6434B power supply.

(3) On the test fixture, place the BLOWER ON-OFF switch to ON, rotate the VOLTAGE SEL switch to +19V, the +23V ON-OFF switch to ON, and then set the HV ON-OFF switch to ON .

(4) Adjust the terminal voltage of the Harrison 6434B power supply to 23.0 ± 0.25 volts .

(5) Record the data required in paragraphs e through o below and compare with the reference standard .

e. Input Current. The dc ammeter shall indicate not more than 12.5 amperes.

f. Power Amplifier Plate Voltage.

(1) Rotate the VOLTAGE SEL switch to +1500V. The DC VOLTAGE meter shall indicate in the red portion of the meter scale.

(2) The ac voltmeter shall read not more than 3.75 volts rms.

g. Power Amplifier Screen Voltage.

(1) Rotate the VOLTAGE SEL switch to +650V. The DC VOLTAGE meter shall indicate in the red portion of the meter scale.

(2) The ac voltmeter shall read not more than 1.50 volts rms

h. Driver Plate Voltage.

(1) Rotate the VOLTAGE SEL switch to +300V. The DC VOLTAGE meter shall indicate in the red portion of the meter scale

(2) The ac voltmeter shall read not more than 0.20 volt rms.

i. Relay Voltage.

(1) On the test fixture, place the HV ON -OFF switch to OFF and rotate the VOLTAGE SEL switch to +26.5V.

(2) The DC VOLTAGE meter shall indicate in the red portion of the meter scale.

j. Filtered Low Voltage.

(1) Rotate the VOLTAGE SEL switch to +23V. The DC VOLTAGE meter shall indicate in the red portion of the meter scale.

(2) The ac voltmeter shall read not more than 0.075 volt rms.

k. Regulated Voltage.

(1) Rotate the VOLTAGE SEL switch to +19V. The DC VOLTAGE meter shall indicate in the red portion of the meter scale.

(2) The ac voltmeter shall read not more than 0.010 volt rms.

(3) Connect the multimeter to test jack J8 (fig. 3-11) on Power Supply PP-3518/PRC-47. On the test fixture, place HV ON-OFF switch to ON and adjust A5R22 (fig. 3-11) to the counterclockwise stop and then to the clockwise stop. The multimeter shall read not more than 18 volts dc nor less than 20 volts dc at the mechanical end stops respectively.

(4) Readjust A5R22 until the multimeter reads 19.0 ± 0.4 volts dc; then return the HV ON-OFF switch on the test fixture to OFF.

l. Filament Voltage.

(1) Rotate the VOLTAGE SEL switch to FIL.

(2) Connect the oscilloscope to AC VOLTAGE jacks on the test fixture in place of the ac voltmeter; then place the HV ON-OFF switch to ON. ;

(3) The oscilloscope shall indicate between 6.0 and 6.3 volts ac peak.

(4) Return the HV ON-OFF switch on the test fixture to OFF and disconnect the oscilloscope.

m. Power Amplifier Bias Voltage.

(1) Connect the ac voltmeter to the AC VOLTAGE jacks on the test fixture and rotate the VOLTAGE SEL switch to -110V

(2) Connect the multimeter to test jack J2 on Power Supply PP-3518/PRC-47.

(3) Place the HV ON-OFF switch to ON and adjust A5R3 (fig. 3-11) to -110 ± 1.0 volts.

(4) The ac voltmeter shall read not more than 0.10 volt rms.

(5) Return the HV ON-OFF switch to OFF and disconnect the multimeter.

n. Driver Bias Voltage.

(1) Rotate the VOLTAGE SEL switch to - 32V

(2) Connect the multimeter to test jack J1 on Power Supply PP-3518/PRC-47.

(3) Place the HV ON-OFF switch to ON and adjust A5R4 (fig. 3-11) to -32.0 ± 0.5 volts.

(4) The ac voltmeter shall read not more than 0.05 volt rms.

(5) Return the HV ON-OFF switch to OFF and disconnect the multimeter.

o. Voltage Regulator Operation.

(1) On the test fixture, place the HV ON-OFF switch to ON.

(2) Connect the multimeter to the output terminals of the Harrison 6434B power supply and adjust the terminal voltage to 22.0 ± 0.1 volts.

(3) Move the multimeter to test jack J8 (fig. 3-11) on Power Supply PP-3518/PRC-47. The voltage at J8 shall read not less than 18.5 volts dc nor more than 19.5 volts dc.

(4) Repeat step (2) except set terminal voltage of Harrison 6434B power supply to 28.0 ± 0.1 volts dc

(5) Repeat step (3). Multimeter readings same as shown in step (3).

p. Performance Tests, 110-Volts, 400-Hz Primary Power Source. The tests listed in paragraph q through u are to be conducted in the sequence shown after these initial conditions are satisfied:

(1) Connect the test equipment to the test fixture as shown in figure 6- 14 using the ac ammeter in the 115-volts, 400-Hz mains.

(2) Install Power Supply PP-3518/PRC-47 in the test fixture.

NOTE

Do not apply primary power to the Harrison 6434B power supply.

(3) On the test fixture, place the BLOWER ON-OFF switch to ON, rotate the VOLTAGE SEL switch to +19V, the +23V switch to OFF, and then set the HV ON-OFF switch to ON.

(4) Record the data required in paragraphs q through u below and compare with the reference standard.

q. Input Current. The ac ammeter shall indicate not more than 3.0 amperes when the ac main is 97.8 to 112.2 volts at 380- to 420-Hz.

r. Relay Voltage.

(1) On the test fixture, place the HV ON-OFF switch to OFF and rotate the VOLTAGE SEL switch to +26.5V.

(2) The DC VOLTAGE meter shall indicate in the red portion of the meter scale.

s. Filtered Low Voltage.

(1) Rotate the VOLTAGE SEL switch to +23V. The DC VOLTAGE meter shall indicate in the red portion of the meter scale.

(2) The ac voltmeter shall read not more than 0.075 volt rms.

t. Regulated Voltage.

(1) Rotate the VOLTAGE SEL switch to +19V. The DC VOLTAGE meter shall indicate in the red portion of the meter scale.

(2) The ac voltmeter shall read not more than 0.010 volt rms.

(3) Connect the multimeter to test jack J8 (fig. 3-11) on Power Supply PP-3518/PRC-47. On the test fixture, place the HV ON-OFF switch to ON and adjust A5R22 to the counterclockwise stop, and then to the clockwise stop. The multimeter shall read not more than 18 volts dc nor less than 20 volts dc at the mechanical end stops respectively.

(4) Readjust A5R22 for 19.0 ± 0.4 volts dc; then return the HV ON-OFF switch to OFF.

u. Filament Voltage.

(1) Rotate the VOLTAGE SEL switch to FIL, and place the HV ON-OFF switch to ON.

(2) The ac voltmeter shall read 5.9 to 6.5 volts rms.

(3) Return the HV ON-OFF switch to OFF.

6-14. Radio Frequency Oscillator 0-1032/PRC-47 (A8A6)

(fig. 7-13)

a. Test Equipment and Material.

(1) Frequency Counter AN/URM-79/U

(2) Multimeter ME-26A/U

(3) Oscilloscope AN/USM-50

(4) Power Supply (24 volts dc) Harrison 6202B (or equal)

(5) Signal Generator SG-103/URM-25F

(6) Test fixture for 0-1032/PRC-47

b. Test Conditions and Equipment Connection

CAUTION

Before connecting the power supply to the test fixture, set the output voltage to 19.0 ± 2.0 volts; then return the power on-off switch to the off position until instructed to apply primary power.

(1) Connect the test instruments to the test fixture as shown in figure 6-15. (The connections for the remaining test equipment are detailed in the appropriate procedural steps below.)

(2) Before placing the O-1032/PRC-47 into the test fixture, remove the module cover. Install module in test fixture.

(3) Place the power on-off switch of the power supply to on and then place the +20 V ON-OFF switch to ON.

(4) Adjust the output voltage of the power supply to 20.0 ± 0.2 volts dc.

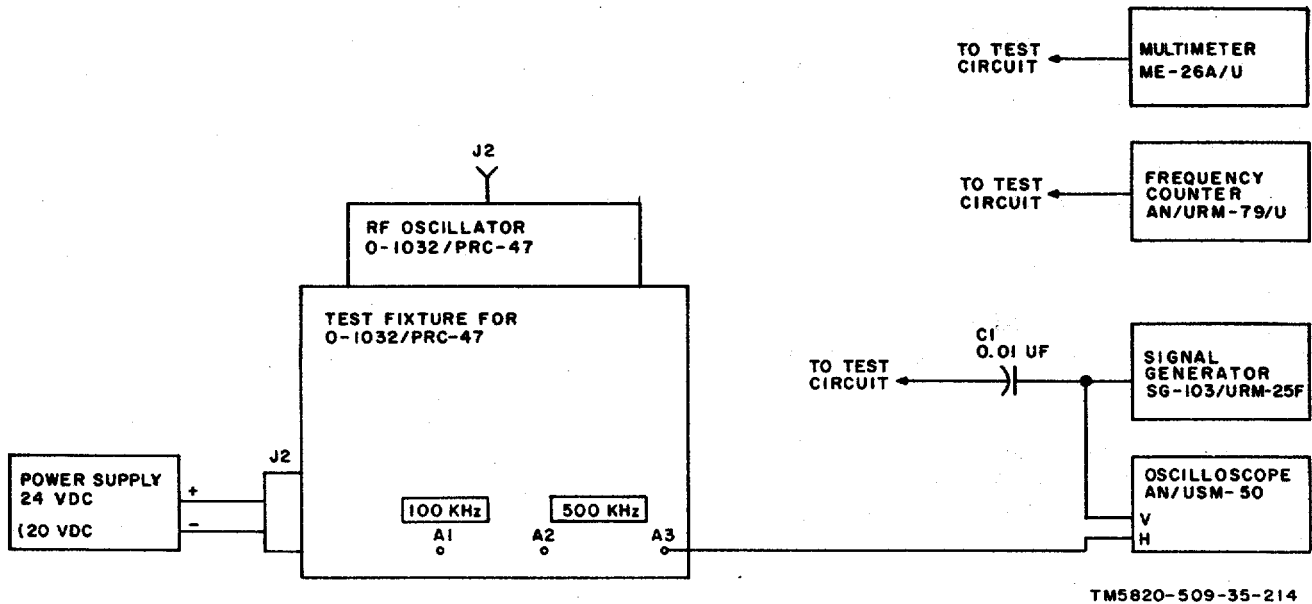

Figure 6-15. RF Oscillator O-1032/PRC-47 (A8A6), Performance Tests, Initial Test Equipment Connections.

c. Initial Settings and Adjustments.

(1) Connect the multimeter dc probe to test point J2 on the module and record the reading obtained. This value must be 17.5 ± 1.0 volts dc.

(2) Press the PUSH TO READ pushbutton on the front of the test fixture and read the current drawn by the module. The +20V CURRENT meter must read 35.0 ± 5.0 milliamperes.

(3) Connect the multimeter rf probe and the frequency counter to the junction of Q4, R23, and R24 (fig. 3-53) and record the output voltage of the temperature compensated oscillator. This voltage shall not be less than 0.3 volt rms and the output frequency shall be approximately 3.0 MHz.

NOTE

Do not adjust or calibrate the temperature compensated oscillator at this time. Final calibration procedures are detailed in step g.

d. Locked Oscillator, Divider, and Output Amplifier Performance.

(1) On the test fixture, place the +20 ON-OFF switch to OFF.

(2) Carefully disconnect the inner conductor of the miniature coaxial cable from the junction of Q4-R23-R24 (fig. 3-53).

(3) Connect the frequency counter to the output of the signal generator; then connect the open end of capacitor C1 to the terminal in the module from which the coaxial cable was disconnected.

(4) Place the +20V ON-OFF switch on the test fixture to ON; then set the signal generator output frequency to 3.000 MHz.

(5) Using the rf probe of the multimeter, adjust the signal generator output level (at the base of locked oscillator Q4) to the value measured in step c (3) above.

NOTE

Be sure to maintain this output level for the remainder of this test.

(6) A stable 6:1 Lissajous pattern must be obtained on the oscilloscope. If not, perform the locked oscillator and 500-kHz amplifier adjustments in step e before continuing.

(7) Vary the signal generator frequency from 2.90 to 3.10 MHz while observing the oscilloscope display. The 6:1 Lissajous pattern must remain clear and stable throughout the signal generator output frequency excursion.

(8) Connect the rf probe of the multimeter to test jack J3 on the module and record the 500 kHz output voltage. Repeat the measurement at test jack J4 on the module. The multimeter shall read 1.5 ± 0.2 volts rms. If not, perform the locked oscillator and 500 kHz amplifier adjustments in step e before continuing.

(9) Connect the vertical input of the oscilloscope to the 100 KHz A1 connector on the front panel of the test fixture. (Do not disturb the signal generator and frequency counter connections in the module.)

(10) A clear, stable 5:1 Lissajous pattern must be displayed on the oscilloscope. If not, perform the locked oscillator and 100-kHz amplifier adjustments in step f before continuing.

(11) Connect the rf probe of the multimeter to test jack J1 on the module and record the 100 kHz output voltage. The multimeter shall read 1.5 ± 0.4 volts rms. If not, perform the locked oscillator and 100-kHz amplifier adjustments in step f before continuing.

(12) Repeat step (7) and observe that the 5:1 Lissajous pattern remains stable and clear through the frequency excursion.

(13) Disconnect the test equipment from the module; place the +20V ON-OFF switch on the test fixture to OFF, and reconnect the center conductor of the miniature coaxial cable removed in step (2) above.

e. *Locked Oscillator Q4 and 500-kHz Amplifier Adjustments.*

NOTE

Perform these procedures only if the stability or output level of the 500 kHz amplifier circuits is deficient. The locked oscillator and amplifier adjustments are performed by selecting specific values for capacitors C14, C20, C25 and

resistors R30 and R45 from the tables below.

(1) On the test fixture, place the +20V ON-OFF switch to OFF, and remove the O-1032/PRC-47 from the test fixture.

(2) Disconnect the miniature coaxial cable from the junction of Q4-R23-R24 as in step d (2) unless it has already been removed, and then replace the module in the test fixture.

(3) Connect the test equipment to the test fixture as shown in figure 6-15 and connect the open end of capacitor C1 to the terminal in the module from which the coaxial cable was just removed.

(4) Return the +20V ON-OFF switch on the test fixture to ON; then set the signal generator output frequency to 3.0 MHz. Adjust the output level of the signal generator at the base of the locked oscillator (Q4) to the value measured in step c (3).

NOTE

Maintain this output level through the remainder of this adjustment procedure.

(5) A clear, stable 6:1 Lissajous pattern must be observed as the signal generator is varied from 2.90 through 3.10 MHz. Select a value of capacitance for C14 from the following table that provides this pattern (refer to fig. 3-53 and 7-13 for part locations).

Capacitor Selection Table

Value	Part No.	Value	Part No.
5 ± 0.5 pf	DM 15C050D01	120 ± 6.0 pf	CM05E121J03
10 ± 0.5 pf	DM 15C100J01	130 ± 6.5 pf	CM05E131J03
12 ± 0.6 pf	DM 15C120J01	140 ± 1.4 pf	DM15E141F0500WV4CR
15 ± 0.7pf	DM 15C150J01	150 ± 7.5 pf	CM05F151J03
18 ± 0.9 pf	DM 15C180J01	160 ± 8.0 pf	CM05F161J03
20 ± 1.0 pf	CM05E200J03	169 ± 1.7 pf	DM15E1690F0300WV4CR
22 ± 1.1 pf	CM05E220J03	180 ± 9.0 pf	CM05F181J03
24 ± 1.2 pf	CM05E240J03	190 ± 1.9 pf	DM15E191F0500WV4CR
27 ± 1.3 pf	CM05E270J03	200 ± 10.0 pf	CM05F201J03
30 ± 1.5 pf	CM05E300J03	220 ± 11.0 pf	CM05F221J03
33 ± 1.6 pf	CM05E330J03	240 ± 12.0 pf	CM05F241J03
36 ± 1.8 pf	CM05E360J03	270 ± 13.5 pf	CM05F271J03
39 ± 1.9 pf	CM05E390J03	300 ± 15.0 pf	CM05F301J03
43 ± 2.1 pf	CM05E430J03	330 ± 16.5 pf	CM05F331J03
47 ± 2.3 pf	CM05E470J03	360 ± 18.0 pf	CM05F361J03
51 ± 2.5 pf	CM05E510J03	390 ± 19.5 pf	CM05F391J03
56 ± 2.8 pf	CM05E560J03	430 ± 21.5 pf	DM15F43 1J03
62 ± 3.1 pf	CM05E620J03	470 ± 23.5 pf	DM15F471J03
68 ± 3.4 pf	CM05E680J03	510 ± 25.5 pf	DM15F511J03
75 ± 3.7 pf	CM05E750J03	560 ± 28.0 pf	DM15F561J300WV4CR
82 ± 4.1 pf	CM05E820J03	620 ± 31.0 pf	DM15F621J300WV4CR
91 ± 4.5 pf	CM05E910J03	750 ± 37.5 pf	CM05F751J03
100 ± 5.0 pf	CM05E101J03	820 ± 41.0 pf	DM15F821J0300WV4CR
110 ± 5.5 pf	CM05E111J03		

NOTE

A more rapid selection of resistor and capacitor values can be made if the component is clipped into the circuit temporarily. All selections may be soldered at the conclusion of the procedure just before final retest.

(6) Adjust the signal generator output frequency to 2970 kHz at the output level established in step (4).

Resistor Selection Table

Value	Part No.	Value	Part No.
2700 ± 270 ohms	RC07GF272K	10000 ± 1000 ohms	RC07GF103K
3300 ± 330 ohms	RC07GF332K	12000 ± 1200 ohms	RC07GF123K
3900 ± 390 ohms	RC07GF392K	16000 ± 1500 ohms	RC07GF153K
4700 ± 470 ohms	RC07GF472K	18000 ± 1000 ohms	RC07GF183K
5600 ± 560 ohms	RC07GF562K	22000 ± 2200 ohms	RC07GF223K
6800 ± 680 ohms	RC07GF682K	27000 ± 2700 ohms	RC07GF273K
8200 ± 820 AA ohms	RC07GF822K		

(9) Move the rf probe of the multimeter to test jack J4 of the module (fig. 3-53) and select a value of capacitance for C25 (figs. 3-53 and 7-13) from the list in the capacitor selection table above until maximum output voltage is obtained at 2970 kHz.

(10) The multimeter reading in step (9) must read 1.5 ± 0.2 volts rms. Adjust the value of resistance for R45 using the values listed in the resistor selection table above to obtain this output reading. (Figures 3-53 and 7-13 show the locations of parts.)

(11) At the conclusion of these adjustments, solder all resistors and capacitors and repeat the procedures listed in step d.

f. Locked Oscillator Q8 and 100-kHz Amplifier Adjustment.

NOTE

Perform these procedures only if the stability or output level of the 100-kHz amplifier circuits is deficient. The locked oscillator and amplifier adjustments are performed by selecting specific values for capacitors C29 and C34 and resistor R46.

(1) Connect the oscilloscope horizontal input to the test fixture at connector 500 KHZ A2, and connect the oscilloscope vertical input to the test fixture at connector 100 KHZ A1.

NOTE

The signal generator and frequency counter remain connected to the junction of Q4-R23-R24 (fig. 3-53) as in step d (3).

(2) Adjust the signal generator output frequency to 3.00 MHz and set the output level to the value established in step c(3)

(7) Connect the rf probe of the multimeter to test jack J3 of the 0-1032/PRC-47 (fig. 3-53) and select a value of capacitance for C20 (fig. 3-53 and fig. 7-13) from the table above that provides maximum voltage at J3.

(8) The multimeter reading in step (7) must read 1.5 ± 0.2 volts rms. Adjust the value of R30 using the selections from the table below to obtain this output reading. Figures 3-53 and 7-13 locate the parts involved in this procedure.

(3) A clear, stable 5:1 Lissajous pattern must be observed as the signal generator is varied from 2.90 to 3.10 MHz. Select a value of capacitance for C29 from the capacitor selection table above that provides this clear, stable 5:1 pattern. (Refer to figs. 3-52 and 7-13 for part locations.)

(4) Adjust the signal generator output frequency to 2970 kHz and maintain the output level used in step 12).

(5) Connect the rf probe of the multimeter to test jack J1 of the module (fig. 3-52) and select a value of capacitance for C34 (figs 3-52 and 7-13) from the list in the capacitor selection table above that provides maximum output at J1.

(6) The multimeter reading in step (5) must read 1.5 ± 0.4 volts rms. Adjust the value of resistance for R46 (using the selections from the table above to obtain this output reading). Figures 3-53 and 7-13 locate the parts involved in this procedure.

(7) Repeat the procedure of step d after permanently soldering all resistors and capacitors in place within the module.

(8) Proceed to step d (12)

g. final Frequency Calibration.

(1) Before beginning this procedure, attach the cover to the module and install the O-1032/PRC-47 in the test fixture.

(2) Connect the frequency counter to connector 500 KHZ A3 on the test fixture, and then place the +20V ON-OFF switch to ON.

NOTE

Do not begin the calibration procedure for at least 1 hour. The unit must be

thoroughly stabilized before each calibration.

(3) Measure the output frequency at connector 500 KHZ A3. The reading must be $500,000.00 \pm 0.05$ Hz. Adjust capacitor C1 (on top of the module) until this reading is obtained.

6-16. Oscillator Control C-4311/PRC-47 (A8A7)

(fig. 7-14)

a. Test Equipment and Material.

- (1) Frequency Counter AN/URM-79/U
- (2) Multimeter ME-26A/U
- (3) Oscilloscope AN/USM-50
- (4) Power Supply 124 volts dc) Harrison 6202B (or equal)
- (5) Signal Generator SG-103/URM-25F (2 required)
- (6) Test fixture for C-4311/PRC-47 with Radio Frequency Oscillator 0-1032/PRC-47 installed.

b. Test Conditions and Equipment Connections.

CAUTION

Before connecting the power supply to the test fixture, set the output voltage to 19.0 ± 2.0 volts dc; then return the power on-off switch to the

off position until instructed to apply primary power.

(1) Connect the test equipment to the test fixture as shown in figure 6-16. (The connections for the remaining test instruments are detailed in the appropriate procedural steps below.)

(2) Verify that Radio Frequency Oscillator 0-1032/PRC-47 is seated securely in its connector within the test fixture.

(3) Before installing Oscillator Control C-4311/PRC-47 in the test fixture, remove the top cover.

NOTE

Verify that the coupling halves on the drive end of the C-4311 /PRC-47 are in the positions shown in figure 3-63 and that the controls (S1 and S2) on the front of the test fixture are in positions O and OO respectively before installing the module in its connector.

(4) Carefully install the module in the test fixture and place the power ON-OFF switch to ON. Turn on the power supply and adjust the output voltage of the 24-volts dc power supply to 20.0 ± 0.2 volts dc.

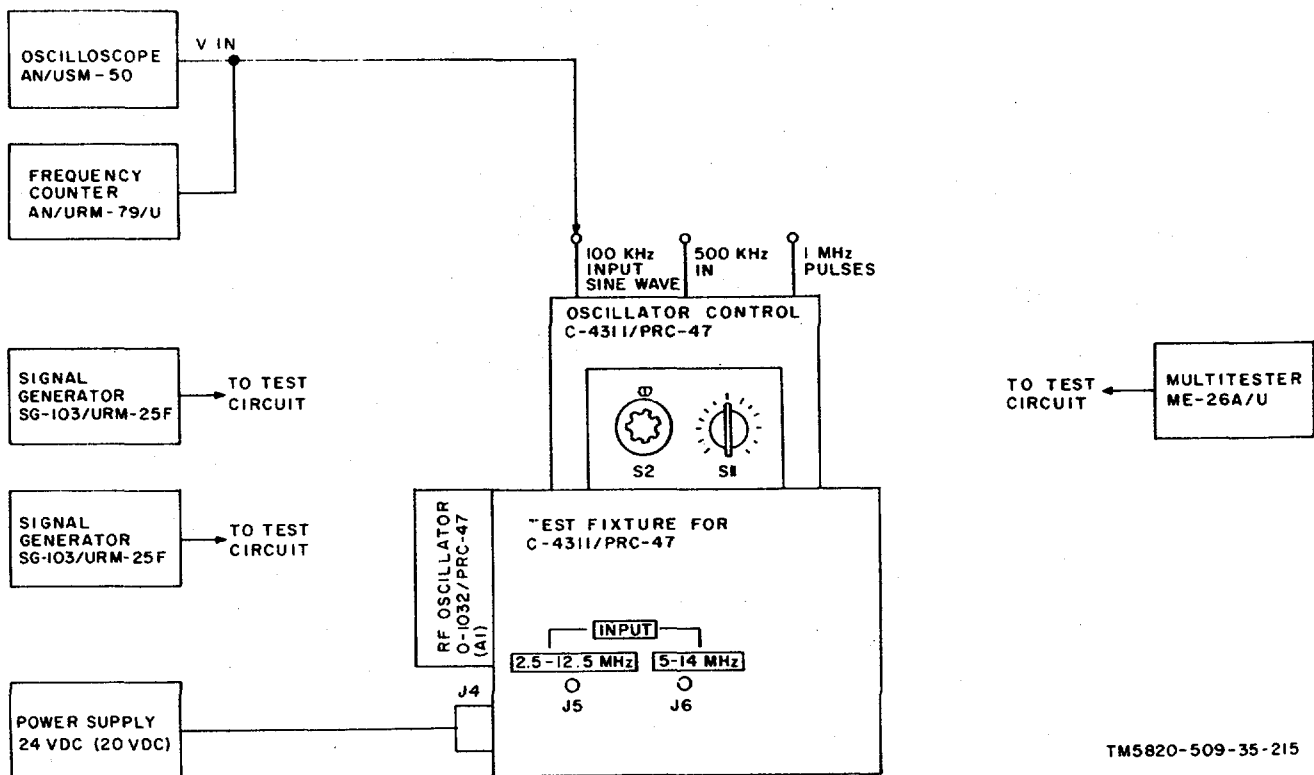

TM5820-509-35-215

Figure 6-16. Oscillator Control C-4311/PRC-47 (A8A7) , Performance Tests, Initial Test Equipment Connections.

c. *Pulse Generator Output.*

(1) Connect the vertical input of the oscilloscope and the frequency counter to 100 kHz sinewave input test point (fig. 3-83) and verify that the amplitude of the waveform is 1.8 ± 0.5 volts peak-to-peak, and that the pulse width is 0.3 ± 0.1 microsecond.

NOTE

The pulse width is the interval between the points on the wave-form where 10 % of the peak amplitude occurs.

(2) Connect the oscilloscope and frequency counter to the 500 kHz input test point (fig. 3-83) and verify that a 500-kHz sinewave signal of approximately 1.5 volts peak-to-peak is present.

(3) Connect the vertical input of the oscilloscope and the frequency counter to the 1 MHz pulses test point (fig. 3-83) and verify that the amplitude of the waveform is 6.0 ± 2.5 volts peak-to-peak, and that the pulse fall time is 0.1 ± 0.03 microsecond.

NOTE

The pulse fall time is the total interval required for the wave to return to the base line from its peak value.

(4) With the oscilloscope connected as in step (3), adjust capacitor C15 (fig. 3-102) for minimum 500 kHz signal in the 1 MHz pulses. Repeat step (3) if a major adjustment is made.

d. *1.8- to 0.9-MHz Ringer Circuit Alignment.*

NOTE

Verify that the ringer circuit is operating properly and not merely oscillating. If oscillating, the frequency will change smoothly as the setting of the trimmer capacitor is varied. If ringing, the wavetrain will be ragged until proper adjustment of the trimmer is obtained, and then the wavetrain will stabilize.

(1) Verify that switches S1 and S2 on the front panel of the test fixture are at O and OO respectively.

(2) Adjust the oscilloscope sweep rate to 10 microseconds per centimeter and connect the vertical input and the frequency counter to the 1.8 - 0.9 MHz input test point (fig. 3-83).

(3) Adjust capacitor C90 (fig. 3-104) for minimum 100-kHz modulation on the oscilloscope trace and observe that the waveform amplitude is not less than 2.3 volts peak-to-peak and that the frequency counter indicates 1.8 MHz.

(4) On the front panel of the test fixture, leave switch S1 at O and rotate switch S2 one complete revolution clockwise to a reading of 1.0.

(5) Adjust capacitor C88 (fig. 3-104) for minimum 100-kHz modulation on the oscilloscope trace and observe that the waveform amplitude is not less than 3.4 volts peak-to-peak and the frequency counter indicates 1.7 MHz.

(6) Repeat step (4) except rotate switch S2 one complete revolution clockwise to a reading of 2.0.

(7) Adjust capacitor C86 (fig. 3-104) for minimum 100-kHz modulation on the oscilloscope trace and observe that the waveform amplitude is not less than 4.3 volts peak-to-peak and the frequency counter indicates 1.6 MHz.

(8) Repeat step (4) except rotate switch S2 one complete revolution clockwise to a reading of 3.0.

(9) Adjust capacitor C84 (fig. 3-104) for minimum 100-kHz modulation on the oscilloscope trace and observe that the waveform amplitude is not less than 3.4 volts peak-to-peak and the frequency counter indicates 1.5 MHz.

(10) Repeat step (4) except rotate switch S2 one complete revolution clockwise to a reading of 4.0.

(11) Adjust capacitor C82 (fig. 3-104) for minimum 100-kHz modulation on the oscilloscope trace and observe that the waveform amplitude is not less than 2.8 volts peak-to-peak and the frequency counter indicates 1.4 MHz.

(12) Repeat step (4) except rotate switch S2 one complete revolution clockwise to a reading of 5.0.

(13) Adjust capacitor C80 (fig. 3-103) for minimum 100-kHz modulation on the oscilloscope trace and observe that the waveform amplitude is not less than 2.6 volts peak-to-peak and the frequency counter indicates 1.3 MHz.

(14) Repeat step (4) except rotate switch S2 one complete revolution clockwise to a reading of 6.0.

(15) Adjust capacitor C78 (fig. 3-103) for minimum 100-kHz modulation on the oscilloscope trace and observe that the waveform amplitude is not less than 2.8 volts peak-to-peak and the frequency counter indicates 1.2 MHz.

(16) Repeat step (4) except rotate switch S2 one complete revolution clockwise to a reading of 7.0.

(17) Adjust capacitor C76 (fig. 3-103) for minimum 100-kHz modulation on the oscilloscope trace and observe that the waveform amplitude is not less than 3.6 volts peak-to-peak and the frequency counter indicates 1.1 MHz.

(18) Repeat step (4) except rotate switch S2 one complete revolution clockwise to a reading of 8.0.

(19) Adjust capacitor C74 (fig. 3-103) for minimum 100-kHz modulation on the oscilloscope

trace and observe that the waveform amplitude is not less 3.3 volts peak-to-peak and the frequency counter indicates 1.0 MHz.

(20) Repeat step (4) except rotate switch S2 one complete revolution clockwise to a reading of 9.0.

(21) Adjust capacitor C72 (fig. 3-103) for minimum 100-kHz modulation on the oscilloscope trace and observe that the waveform amplitude is not less than 3.3 volts peak-to-peak and the frequency counter indicates 0.9 MHz.

e. *Crystal Oscillator Alignment.*

(1) Set switches S1 and S2 on the front panel of the test fixture to O and OO respectively.

(2) Attach clips to the leads of a 0.01 microfarad capacitor and install it from the outer case of variable capacitor C131 (fig. 3-100) to chassis ground (module drive end plate).

(3) Place the frequency counter input probe at the base of transistor Q21 (common junction of C100, C101, R111, and R112 on fig. 3-59) and verify that oscillator Q21 output frequency is $3,707,000.00 \pm 1.0$ Hz. If not, adjust capacitor C133 (fig. 3-101) on the bottom of the module to obtain this reading.

(4) Remove the 0.01 microfarad capacitor installed in step (2) and connect the oscilloscope vertical input and the frequency counter to jack J1 (fig. 3-100). Verify that the output frequency is $700,000.00 \pm 1.0$ Hz. If not, adjust capacitor C113 (fig. 3-101) on the bottom of the module to obtain this reading.

(5) Repeat step (4) with switch S1 on the front of the test fixture at 1. Verify that the output frequency is $699,000.00 \pm 1.0$ Hz. If not, adjust capacitor C115 (fig. 3-101) on the bottom of the module to obtain this reading.

(6) Repeat step (4) with switch S1 on the front of the test fixture at 2. Verify that the output frequency is $698,000.00 \pm 1.0$ Hz. If not, adjust capacitor C117 (fig. 3-101) on the bottom of the module to obtain this reading.

(7) Repeat step (4) with switch S1 on the front of the test fixture at 3. Verify that the output frequency is $697,000.00 \pm 1.0$ Hz. If not, adjust capacitor C119 (fig. 3-101) on the bottom of the module to obtain this reading.

(8) Repeat step (4) with switch S1 on the front of the test fixture at 4. Verify that the output frequency is $696,000.00 \pm 1.0$ Hz. If not, adjust capacitor C121 (fig. 3-101) on the bottom of the module to obtain this reading.

(9) Repeat step (4) with switch S1 on the front of the test fixture at 5. Verify that the output frequency is $695,000.00 \pm 1.0$ Hz. If not, adjust capacitor C123 (fig. 3-100) on the top of the module to obtain this reading.

(10) Repeat step (4) with switch S1 on the front of the test fixture at 6. Verify that the output frequency is $694,000.00 \pm 1.0$ Hz. If not, adjust capacitor C125 (fig. 3-100) on the top of the module to obtain this reading.

(11) Repeat step (4) with switch S1 on the front of the test fixture at 7. Verify that the output frequency is $693,000.00 \pm 1.0$ Hz. If not, adjust capacitor C127 (fig. 3-100) on the top of the module to obtain this reading.

(12) Repeat step (4) with switch S1 on the front of the test fixture at 8. Verify that the output frequency is $692,000.00 \pm 1.0$ Hz. If not, adjust capacitor C129 (fig. 3-100) on the top of the module to obtain this reading.

(3) Repeat step (4) with switch S1 on the front of the test fixture at 9. Verify that the output frequency is $691,000.00 \pm 1.0$ Hz. If not, adjust capacitor C131 (fig. 3-100) on the top of the module to obtain this reading.

(14) On the test fixture, return switch S1 to 0. Rotate switch S1 to 1.0 and verify that the output frequency is $690,000.00 \pm 1.0$ Hz. If not, adjust capacitor C135 (fig. 3-101) on the bottom of the module to obtain this reading.

(15) Repeat step (14) except place switch S2 on the front of the test fixture to 2.0 and verify that the output frequency is $680,000.00 \pm 1.0$ Hz. If not, adjust capacitor C137 (fig. 3-101) on the bottom of the module to obtain this reading.

(16) Repeat step (14) except place switch S2 on the front of the test fixture to 3.0 and verify that the output frequency is $670,000.00 \pm 1.0$ Hz. If not, adjust capacitor C139 (fig. 3-101) on the bottom of the module to obtain this reading.

(17) Repeat step (14) except place switch S2 on the front of the test fixture to 4.0 and verify that the output frequency is $660,000.00 \pm 1.0$ Hz. If not, adjust capacitor C141 (fig. 3-101) on the bottom of the module to obtain this reading.

(18) Repeat step (14) except place switch S2 on the front of the test fixture to 5.0 and verify that the output frequency is $650,000.00 \pm 1.0$ Hz. If not, adjust capacitor C143 (fig. 3-100) on the top of the module to obtain this reading.

(19) Repeat step (14) except place switch S2 on the front of the test fixture to 6.0 and verify that the output frequency is $640,000.00 \pm 1.0$ Hz. If not, adjust capacitor C145 (fig. 3-100) on the top of the module to obtain this reading.

(20) Repeat step (14) except place switch S2 on the front of the test fixture to 7.0 and verify that the output frequency is $630,000.00 \pm 1.0$

Hz. If not, adjust capacitor C147 (fig. 3-100) on the top of the module to obtain this reading.

(21) Repeat step (14) except place switch S2 on the front of the test fixture to 8.0 and verify that the output frequency is $620,000.00 \pm 1.0$ Hz. If not, adjust capacitor C149 (fig. 3-100) on the top of the module to obtain this reading.

(22) Repeat step (14) except place switch S2 on the front of the test fixture to 9.0 and verify that the output frequency is $610,000.00 \pm 1.0$ Hz. If not, adjust capacitor C151 (fig. 3-100) on the top of the module to obtain this reading.

f. 601- to 700-kHz Filter Test.

(1) Connect the oscilloscope vertical input and the frequency counter to jack J1 (fig. 3-100).

(2) On the test fixture, set switches S1 and S2 to O and OO respectively and verify that the waveform amplitude is 1.1 ± 0.2 volts peak-to-peak and the output frequency is 700 kHz.

(3) Rotate switches S1 and S2 to 1 and 1.0 respectively and verify that the waveform amplitude is 1.1 ± 0.2 volts peak-to-peak and the output frequency is 689 kHz.

(4) Rotate switches S1 and S2 to 2 and 2.0 respectively and verify that the waveform amplitude is 1.1 ± 0.2 volts peak-to-peak and the output frequency is 678 kHz.

(5) Rotate switches S1 and S2 to 3 and 3.0 respectively and verify that the waveform amplitude is 1.1 ± 0.2 volts peak-to-peak and the output frequency is 667 kHz.

(6) Rotate switches S1 and S2 to 4 and 4.0 respectively and verify that the waveform amplitude is 1.1 ± 0.2 volts peak-to-peak and the output frequency is 656 kHz.

(7) Rotate switches S1 and S2 to 5 and 5.0 respectively and verify that the waveform amplitude is 1.1 ± 0.2 volts peak-to-peak and the output frequency is 645 kHz.

(8) Rotate switches S1 and S2 to 6 and 6.0 respectively and verify that the waveform amplitude is 1.1 ± 0.2 volts peak-to-peak and the output frequency is 634 kHz.

(9) Rotate switches S1 and S2 to 7 and 7.0 respectively and verify that the waveform amplitude is 1.1 ± 0.2 volts peak-to-peak and the output frequency is 623 kHz.

(10) Rotate switches S1 and S2 to 8 and 8.0 respectively and verify that the waveform amplitude is 1.1 ± 0.2 volts peak-to-peak and the output frequency is 612 kHz.

(11) Rotate switches S1 and S2 to 9 and 9.0 respectively and verify that the waveform amplitude is 1.1 ± 0.2 volts peak-to-peak and the output frequency is 601 kHz.

g. 550- to 750-kHz Filter Test.

(1) Attach clips to the leads of a 0.01 microfarad capacitor and install it from the outer case of variable capacitor C131 (fig. 3-100) to chassis ground (module drive end plate).

(2) Attach clips to the leads of a second 0.01 microfarad capacitor and connect it between the signal generator and transformer T3 at its junction with C165 and R147.

(3) Connect the oscilloscope vertical input and the frequency counter to jack J4 (fig. 3-100) and vary the signal generator output frequency from 500- to 800-kHz. Observe the frequency at which maximum output occurs and set the signal generator output to provide 1.0 volt peak-to-peak at jack J4.

(4) Set the output frequency of the signal generator to 500 kHz, and verify that the output amplitude does not exceed 0.2 volt peak-to-peak.

(5) Set the output frequency of the signal generator to 525 kHz, and verify that the output amplitude does not exceed 0.7 volt peak-to-peak.

(6) Set the output frequency of the signal generator to 550 kHz, and verify that the output amplitude remains between 0.3 and 1.0 volt peak-to-peak.

(7) Repeat step (6) with the signal generator set to 575 kHz.

(8) Repeat step (6) with the signal generator set to 600 kHz.

(9) Repeat step (6) with the signal generator set to 625 kHz.

(10) Repeat step (6) with the signal generator set to 650 kHz.

(11) Repeat step (6) with the signal generator set to 675 kHz.

(12) Repeat step (6) with the signal generator set to 700 kHz.

(13) Repeat step (6) with the signal generator set to 725 kHz.

(14) Set the output frequency of the signal generator to 750 kHz, and verify that the output amplitude does not exceed 0.7 volt peak-to-peak.

(15) Set the output frequency of the signal generator to 800 kHz, and verify that the output amplitude does not exceed 0.2 volt peak-to-peak.

h. Frequency Discriminator Test

(1) Disconnect the 0.01 microfarad capacitor from the outer case of variable capacitor C131 to chassis ground installed in step g (1)

(2) Verify that the signal generator is connected to the junction of T3-C165-R147 (fig. 3-56) with the 0.01 microfarad capacitor. and connect the oscilloscope to jack J4 (fig. 3-14) and the multimeter to jack J5 (fig. 3-15) on the module.

(3) On the test fixture, set switches S1 and S2 to O and OO respectively and then adjust the signal generator output frequency to 650 kHz and set the output level to 0.1 volt rms.

(4) Observe that the multimeter reads not less than 4.0 volts dc at jack J5. Then move the multimeter probe to jack J6 (fig. 3-14) and observe that the multimeter reads not more than 1.5 volts dc.

(5) Adjust the signal generator output frequency to 690 kHz at an output level of 0.1 volt rms and verify that the conditions recorded in step (4) are obtained.

(6) Adjust the signal generator output frequency to 710 kHz at an output level of 0.1 volt rms.

(7) Observe that the multimeter reads not more than 1.5 volts dc at jack J5. Then move the multimeter probe to jack J6 (fig. 3-14) and observe that the multimeter reads not less than 4.0 volts dc.

(8) Adjust the signal generator output frequency to 750 kHz at an output level of 0.1 volt rms and verify that the conditions recorded in step (7) are obtained.

(9) Adjust the signal generator output frequency to 550 kHz at a level of 0.1 volt rms and note that the waveform at jack J4 is slightly clipped.

(10) On the test fixture, rotate switch S2 to 6.0 with S1 remaining at O. Adjust the signal generator output frequency to 600 kHz at an output level of 0.1 volt rms.

(11) Observe that the multimeter reads not less than 4.0 volts dc at jack J5 (fig. 3-14). Then move the multimeter probe to jack J6 (fig. 3-14) and observe that the multimeter reads not more than 1.5 volts dc.

(12) Adjust the signal generator output frequency to 640 kHz at an output level of 0.1 volt rms and verify that the conditions recorded in step (11) are obtained.

(13) Adjust the signal generator output frequency to 660 kHz at an output level of 0.1 volt rms.

(14) Observe that the multimeter reads not more than 1.5 volts dc at jack J5. Then move the multimeter probe to jack J6 (fig. 3-14) and observe that the multimeter reads not less than 4.0 volts dc.

(15) Adjust the signal generator output frequency to 700 kHz at an output level of 0.1 volt rms and verify that the conditions recorded in step (14) are obtained.

(16) On the test fixture, rotate switches S1 and S2 to 9.0 and 9 respectively and adjust the

signal generator output frequency to 550 kHz at an output level of 0.1 volt rms.

(17) Observe that the multimeter reads not less than 4.0 volts dc at jack J5 (fig. 3-14). Then move the multimeter probe to jack J6 (fig. 3-14) and observe that the multimeter reads not less than 1.5 volts dc.

(18) Adjust the signal generator output frequency to 590 kHz at an output level of 0.1 volt rms and verify that the conditions recorded in step (17) are obtained.

(19) Adjust the signal generator output frequency to 610 kHz at an output level of 0.1 volt rms.

(20) Observe that the multimeter reads not more than 1.5 volts dc at jack J5 (fig. 3-14). Then move the multimeter probe to jack J6 (fig. 3-14) and observe that the multimeter reads not less than 4.0 volts dc.

(21) Adjust the signal generator output frequency to 650 kHz at an output level of 0.1 volt rms and verify that the conditions recorded in step (20) are obtained.

(22) Verify that the oscilloscope is connected to jack J4 and that the multimeter reads not less than 4.0 volts dc at jack J6, as in step (20). Then disconnect the signal generator, and observe that the multimeter reading remains essentially unchanged.

(23) Adjust the signal generator output frequency to 490 kHz at an output level of 0.1 volt rms and reconnect the output terminals to the common junction of T3-C165-R147 (fig. 3-56) in the module using the 0.01 microfarad capacitor as in step (2).

(24) Adjust the signal generator output frequency toward 600 kHz while observing the multimeter reading. A sharp decrease in the meter reading (to approximately 1.5 volts dc) must occur at, or above, 525 kHz.

(25) Connect the multimeter to jack J5 (fig. 3-14) and observe that the discriminator output is not less than 4.0 volts dc. Then disconnect the signal generator from the module and observe that the multimeter reading remains essentially unchanged.

(26) Adjust the signal generator output frequency to 810 kHz at an output level of 0.1 volt rms and reconnect the output terminals to the common junction of T3-C165-R147 (fig. 3-56) in the module using the 0.01 microfarad capacitor as in step (2).

(27) Adjust the signal generator output frequency toward 600 kHz while observing the multimeter reading. A sharp decrease in the meter reading (to approximately 1.5 volts dc) must occur at, or below, 675 kHz.

NOTE

If the error line voltages (measured at jacks J5 and J6) are not within the limits specified in steps (4) through (21), or if the error line voltage reversals measured in steps (24) and

(27) occur between 550- and 650-kHz, substitute a new value for resistance R144 (fig. 3-56) from the following table using the procedure in step i to obtain optimum operating characteristics.

Resistance Selection Chart

Value	Part No.	Value	Part No.
10.0 ± 1.0 ohms	RC07GF100K	470 ± 47 ohms	RC07GF471K
82.0 ± 8.2 ohms	RC07GF820K	680 ± 68 ohms	RC07GF681K
150 ± 15 ohms	RC07GF151K	820 ± 82 ohms	RC07GF 821K
220 ± 22 ohms	RC07GF 221K	1000 ± 100 ohms	RC07GF102K
330 ± 33 ohms	RC07GF331K	1600 ± 150 ohms	RC07GF152K

i. Error Voltage Balance Adjustment.

NOTE

Perform these procedures only if the error voltages or voltage reversals in step h are beyond acceptable limits.

(1) On the test fixture, set switch S1 to 0 and switch S2 to 6.0.

(2) Connect the signal generator output terminals to the common junction of T3-C165R147 (fig. 3-56) and adjust the output frequency to 660 kHz at an output level of 0.1 volt rms.

(3) Refer to figures 3-55 and 7-14. Connect the oscilloscope alternately to the collector circuit of transistor Q9 (common junction of Q9-C25-L3) and the collector circuit of transistor Q12 (common junction of Q12-C32-L6) while substituting values for resistor R144 (fig. 3-56).

(4) Select a suitable value of resistance for R144 from the chart above that provides maximum 10-kHz modulation at both Q9 and Q12 collector circuits.

NOTE

Some compromise in this resistance value will be required to obtain nearly equal levels of modulation at both collector circuits.

j. Anti-lock Test.

(1) Connect the signal generator output terminals to the common junction of T3-C165R147 (fig. 3-56) and adjust the output frequency to 700 kHz at an output level of 0.1 volt rms.

(2) Connect the oscilloscope to jack J4 on the module.

(3) Observe that the ANIT-LOCK lamp on the test fixture is lit.

(4) Increase the signal generator output level until the ANTI-LOCK lamp goes out. The voltage at jack J4 shall be 1.05 volts peak-to-peak on the oscilloscope.

(5) Lower the signal generator output level until the ANTI-LOCK lamp lights, and observe that the

voltage at jack J4 remains at 1.05 volts peak-to-peak approximately.

k. SMO Mixers Test.

(1) Connect signal generator no. 1 to the 5-14 MHz INPUT jack on the front of the test fixture.

(2) Connect the oscilloscope probe to the primary of transformer T1 (fig. 3-56, at junction with coaxial input cable near jack J2) on terminal board TB1.

(3) Adjust the output frequency of signal generator no. 1 to 5.0 MHz at an output level of 2.4 volts peak-to-peak on the oscilloscope.

(4) Connect signal generator no. 2 to the 2.512.5 MHz INPUT jack on the front of the test fixture, and move the oscilloscope probe to jack J3 (fig. 3-14).

(5) Adjust the output frequency of signal generator no. 2 to 2.55 MHz at an output level of 6.0 volts peak-to-peak on the oscilloscope.

(6) Connect the oscilloscope probe to jack J4 (fig. 3-14) and observe that the mixer output level is 1.5 ± 0.4 volts peak-to-peak.

(7) Repeat step (2) and adjust the output frequency of signal generator no. 1 to 6.0 MHz at an output level of 2.1 volts peak-to-peak on the oscilloscope.

(8) Repeat step (4) and adjust the output frequency of signal generator no. 2 to 3.55 MHz at an output level of 4.4 volts peak-to-peak on the oscilloscope.

(9) Repeat step (6). The mixer output shall be 1.5 ± 0.4 volts peak-to-peak.

(10) Repeat step (2) and adjust the output frequency of signal generator no. 1 to 7.0 MHz at an output level of 1.8 volts peak-to-peak on the oscilloscope.

(11) Repeat step (4) and adjust the output frequency of signal generator no. 2 to 4.55 MHz at an output level of 6.0 volts peak-to-peak on the oscilloscope.

(12) Repeat step (6). The mixer output shall be 1.5 ± 0.4 volts peak-to-peak.

(13) Repeat step (2) and adjust the output frequency of signal generator no. 1 to 8.0 MHz at an output level of 1.5 volts peak-to-peak on the oscilloscope.

(14) Repeat step (4) and adjust the output frequency of signal generator no. 2 to 5.55 MHz at an output level of 6.8 volts peak-to-peak on the oscilloscope.

(15) Repeat step (6). The mixer output shall be 1.5 ± 0.4 volts peak-to-peak.

(16) Repeat step (2) and adjust the output frequency of signal generator no. 1 to 9.0 MHz at an output level of 1.4 volts peak-to-peak on the oscilloscope.

(17) Repeat step (4) and adjust the output frequency of signal generator no. 2 to 6.55 MHz at an output level of 8.0 volts peak-to-peak on the oscilloscope.

(18) Repeat step (6). The mixer output shall be 1.5 ± 0.4 volts peak-to-peak.

(19) Repeat step (2) and adjust the output frequency of signal generator no. 1 to 10.0 MHz at an output level of 1.3 volts peak-to-peak on the oscilloscope.

(20) Repeat step (4) and adjust the output frequency of signal generator no. 2 to 7.55 MHz at an output level of 4.3 volts peak-to-peak on the oscilloscope.

(21) Repeat step (6). The mixer output shall be 1.5 ± 0.4 volts peak-to-peak.

(22) Repeat step (2) and adjust the output frequency of signal generator no. 1 to 11.0 MHz at an output level of 1.3 volts peak-to-peak on the oscilloscope.

(23) Repeat step (4) and adjust the output frequency of signal generator no. 2 to 8.55 MHz at an output level of 3.6 volts peak-to-peak on the oscilloscope.

(24) Repeat step (6) The mixer output shall be 1.5 ± 0.4 volts peak-to-peak.

(25) Repeat step (2) and adjust the output frequency of signal generator no. 1 to 12.0 MHz at an output level of 1.2 volts peak-to-peak on the oscilloscope.

(26) Repeat step (4) and adjust the output frequency of signal generator no. 2 to 9.55 MHz at an output level of 3.7 volts peak-to-peak on the oscilloscope.

(27) Repeat step (6). The mixer output shall be 1.5 ± 0.4 volts peak-to-peak.

(28) Repeat step (2) and adjust the output frequency of signal generator no. 1 to 13.0 MHz at an output level of 1.2 volts peak-to-peak on the oscilloscope.

(29) Repeat step (4) and adjust the output frequency of signal generator no. 2 to 10.56 MHz at an output level of 3.4 volts peak-to-peak on the oscilloscope.

(30) Repeat step (6). The mixer output shall be 1.5 ± 0.4 volts peak-to-peak.

(31) Repeat step (2) and adjust the output frequency of signal generator no. 1 to 14.0 MHz at an output level of 1.1 volts peak-to-peak on the oscilloscope.

(32) Repeat step (4) and adjust the output frequency of signal generator no. 2 to 11.55 MHz at an output level of 3.3 volts peak-to-peak on the oscilloscope.

(33) Repeat step (6). The mixer output shall be 1.5 ± 0.4 volts peak-to-peak

Section III. SPECIAL TEST FIXTURES

6-16. General

This section describes the special test fixtures required for performance of the reference standards tests described in the preceding sections of this chapter. Information is included that permits fabrication of the individual test fixtures from readily available parts, and includes parts lists, schematic diagrams and parts location photographs.

6-17. Test Fixture for Audio Frequency Amplifier AM-3506JPRC-47.

(fig. 7-15)

a. *The test fixture for Audio Frequency*

Amplifier AM-3506/PRC-47 contains all switches, jacks, lamps and meters necessary to electrically test and adjust the module without providing a complete AN/PRC-47 Radio Set. Power for the test fixture and the module under test is provided externally and connected to the test fixture by a specially fabricated cable attached to power connector J2 at the rear of the test fixture.

b. *The operating controls on the front panel of the test fixture (fig. 6-4) perform the following functions:*

(1) POWER ON-OFF switch. This toggle switch controls the +24 volts dc and -7 volts dc

input voltages to the test fixture and the module.

(2) POWER ON lamp. This indicator is lit when power is connected to the test fixture and the POWER ON-OFF switch is in the ON position.

(3) POWER 24 VDC 1/2 AMP fuse. This protective device is connected in the +24 volts dc primary power circuit to protect it from overload.

(4) PTT ON-OFF-MOM ON switch. This toggle switch enables the transmit mode in the module when placed in either the ON or MOM ON positions for simulated voice operation.

(5) KEY ON OFF-MOM ON switch. This toggle switch enables the transmit mode in the module when placed in either the ON or MOM ON positions for simulated telegraph operation.

(6) +20V/ +24V switch. This rotary switch places the MODULE CURRENT meter in series with either the +20 volts power input to the module, or the

+24 volts power input to the module to determine the circuit current drain.

(7) MODULE CURRENT meter. This 0- 150 millimeter indicates the dc current drain of the module.

(8) VOX ON lamp. This indicator is lit whenever the PTT ON-OFF-MOM ON switch is placed to ON or MOM ON.

(9) SIDETONE GATE ADJUST control. This potentiometer varies the sidetone gate bias applied to the receiver amplifier circuit of the module.

(10) Test jacks and binding poets are provided for the attachment of signal leads and test equipment and are self-explanatory.

c. The piece parts required for fabrication of the test fixture are listed in the following chart and suggested parts placement is shown in figures 6-17 and 6-18. Schematic diagram (fig. 715) illustrates the internal circuit of the test fixture.

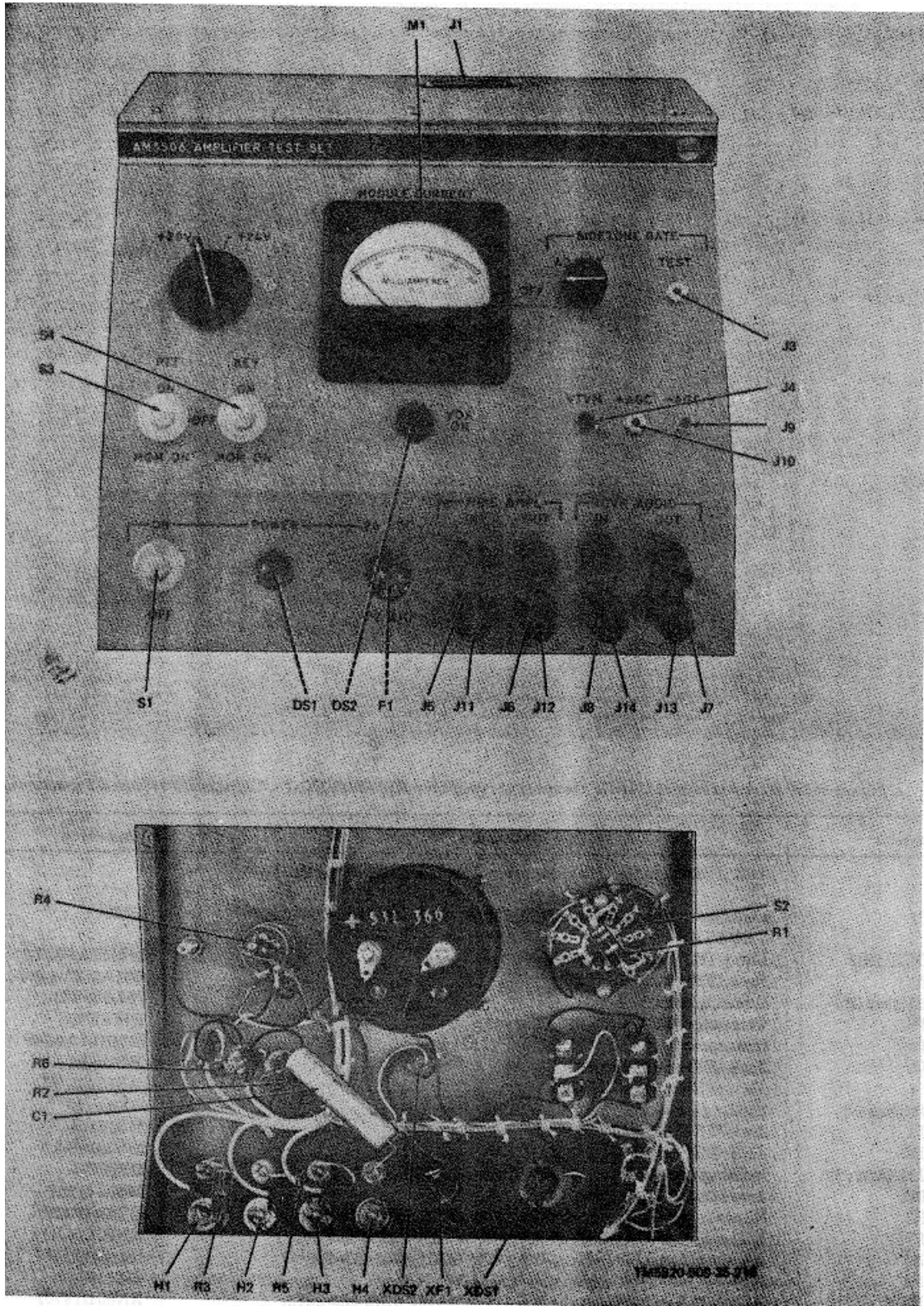

Figure 6-17. Test Fixture for Audio Frequency Amplifier AM-3506/PRC47, Parts Location.

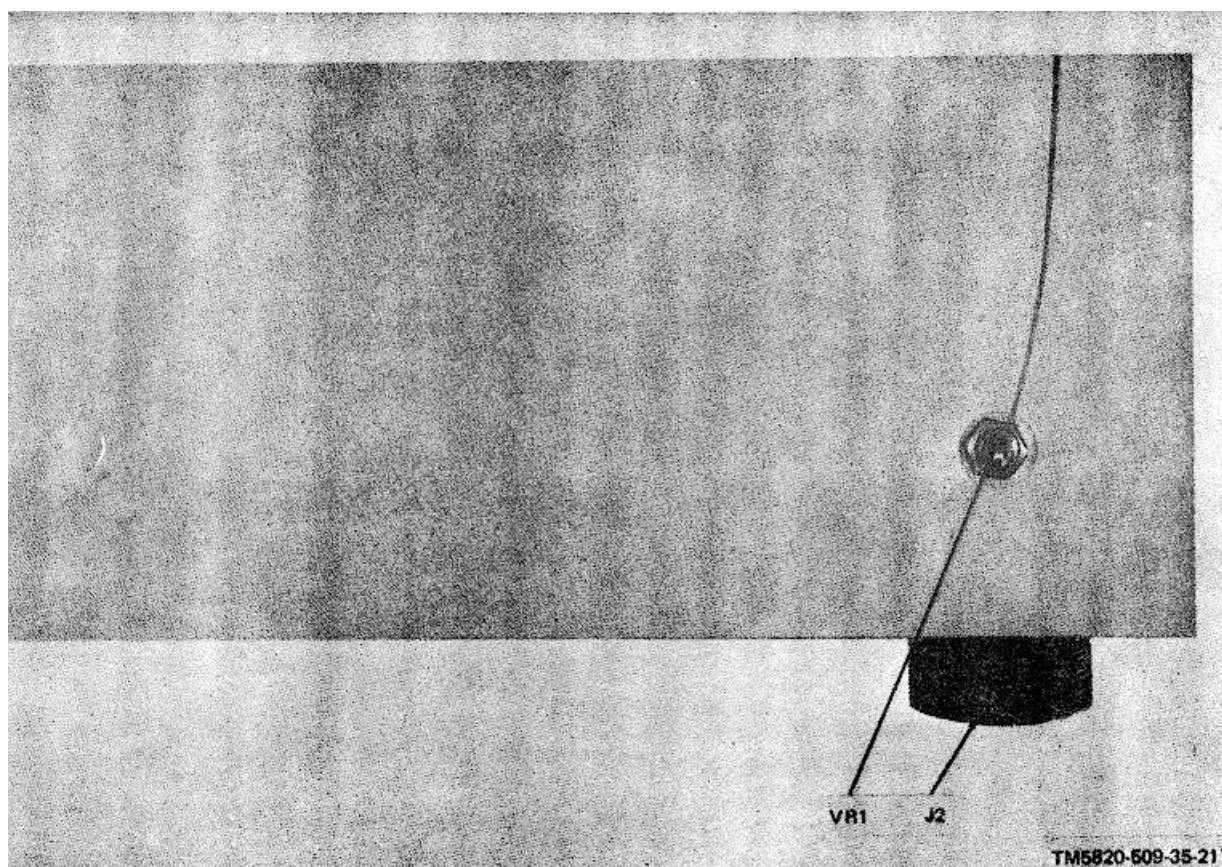

Figure 6-18. Test Fixture for Audio Frequency Amplifier AM-3506/PRC-47, Chassis Parts and Connector Location.

Symbol	Description	Mfgr Part No.	Mfgr Code
	Test Fixture for Audio Frequency Amplifier AM-3506/PRC-47		
C1	Capacitor fixed, 100 uf P100M10%,%, 60 vdcw (FSN 5910-829-0109TA;	D31971	66280
DS1, DS2	Lamp (FSN 6240 069 6349)	MS25237-327-15	
F1	Fuse (FSN 5920-281-0224)	F02A250V1-2AS	
H1 thru H4	Contact, electrical	767 5609-001	13499
J1	Connector (FSN 5935-883-0218)	DBMF25S	71468
J2	Connector	MS3102A24-28P	
J3	Jack (FSN 5935-685-9396)	MS16108-1A	
J4	Jack (FSN 6935-578-3489)	MS16108-2A	
J5 thru J8	Binding poet (FSN 5940-816-8363)	DF30GNC	58474
J9	Jack (FSN 5935-577-2338)	MS16108-6A	
J10	Jack (FSN 5935-681-5689)	MS16108-8A	
J11 thru J14	Binding poet (FSN 5940-556-6194)	DF30BC	58474
M1	Ammeter, 0 - 160 ma.	MS31-2-218	82386
R1	Resistor fixed, 33 ohms 10%, 2 W (FSN 6806-270-2630)	RC42GF330K	
R2	Resistor, fixed, 61.1 ohms 1%, 1/4 W (FSN 5905-957-8633)	RN60D51 R1F	
R3	Resistor, fixed 300 ohms, 6%, 2 W (FSN 5905-279-2024)	RC42GF301J	
R4	Resistor var., 1000 ohms 10% 12.6 W	E-0119	01121
R5	Resistor, fixed 147 ohms, 1%, 'A W (FSN 5905-069-3910)	RN60D1470F	
R6	Resistor, fixed, 22,000 ohms 10% 1 W (FSN 5906-299-2019)	RC32GF223K	
S1	Switch (FSN 6930-665-15B2)	MS35059-23	
S2	Switch, wafer 3 cir.	266738-H1	76864
S3, S4	Switch (FSN 5930-665-1523)	ST42H	

Symbol	Description	Mfgr Part No.	Mfgr Code
VR1	Semiconductor device, diode, 20 V 5%	1N2984B	
XDS1, XDS2	Light (FSN 6210-825-2051)	101-3830-9	72619
	Lens, p/o XDS1 (FSN 6210-511-8208)	101-972	72619
	Lens p/o XDS2 (FSN 6210-174-4680)	101-974	72619
XF1	Fuseholder (FSN 5920-284-7144)	HKPH	71400

Note. All manufacturer's codes are 5-digit numbers. The corresponding manufacturer's name and address are listed in SB 708-42 Catalog Handbook (H4-2).

6-18. Teat Fixture for Amplifier-Modulator AM-3507/PRC-47

(fig. 7-16)

a. The teat fixture for Amplifier-Modulator AM-3507/PRC-47 contains all switches, jacks, tamps, and meter necessary to electrically test and adjust the module without providing a complete AN/PRC-47 Radio Set. Power for the test fixture and the module under test is provided externally and is connected to the test fixture by a specially fabricated cable attached to power connector J3 at the rear of the teat fixture.

b. The operating controls on the front panel of the test fixture (fig. 6-5) perform the following functions:

(1) POWER ON-OFF switch. This toggle switch controls the +20 volts dc the +6 volts dc and the -110 volts dc input voltages to the test fixture and the module.

(2) POWER lamp. This indicator is lit when power is connected to the +20 volts dc input of the teat fixture and the POWER ON-OFF switch is in the ON position.

(3) POWER 1/2 AMP 28 VDC fuse. This protective device is connected in the +20 volts dc primary power circuit to protect it from overload.

(4) ALC BIAS ON-OFF switch. This switch controls the +6 volt dc alc bias applied to the module under test.

(5) ALC BIAS ADJUST control. This potentiometer varies the magnitude of effective bias on the -alc line to the module being tested

(6) MICROAMPERES meter. This 0 - 50 microammeter indicates the amount of alc bias current flowing in the module.

(7) METER RANGE 50 - 200 switch. This switch, when placed in the 200 position, connects a shunt across MICROAMPERES meter to extend its range to 200 microamperes.

(8) XMIT RCVR switch. This toggle switch selects the transmit mode, or the receive mode of operation for the module under test.

(9) AGC ON-OFF switch. This toggle switch, when placed in the ON position, applies positive agc bias to the module under test.

(10) AGC ADJUST control. This potentiometer varies the magnitude of bias applied to the agc bias input to the module being tested.

(11) Test jacks and coaxial connectors are provided for the attachment of signal leads and test equipment and are self-explanatory.

c. The piece parts required for fabrication of the test fixture are listed in the following chart and suggested parts placement is shown in figures 6-19 and 6-20. Schematic diagram (fig. 716) illustrates the internal circuit of the test fixture.

d. The following calibration procedure is required prior to initial use of the test fixture, and should be verified from time to time prior to its use.

(1) Remove the dust cover from the test fixture and connect the 20 volts dc power supply to the power cable.

(2) Apply primary power to the 20 volts dc power supply and adjust the power supply output voltage to 20.0 ± 0.5 volts.

(3) Connect the frequency counter and multimeter rf probe to connector J2 at pin A2.

(4) Place the POWER ON-OFF switch on the test fixture to ON and permit the test fixture to stabilize for at least five minutes. Place the XMIT-RCVR switch to XMIT.

(5) Adjust capacitor C6 (fig. 6-20 and fig. 7. 16) until the frequency counter indicates $500,000.00 \pm 1.0$ Hz; then adjust potentiometer R4 (fig. 6-20 and fig. 7-16) for a multimeter reading of +1.5 volts rms.

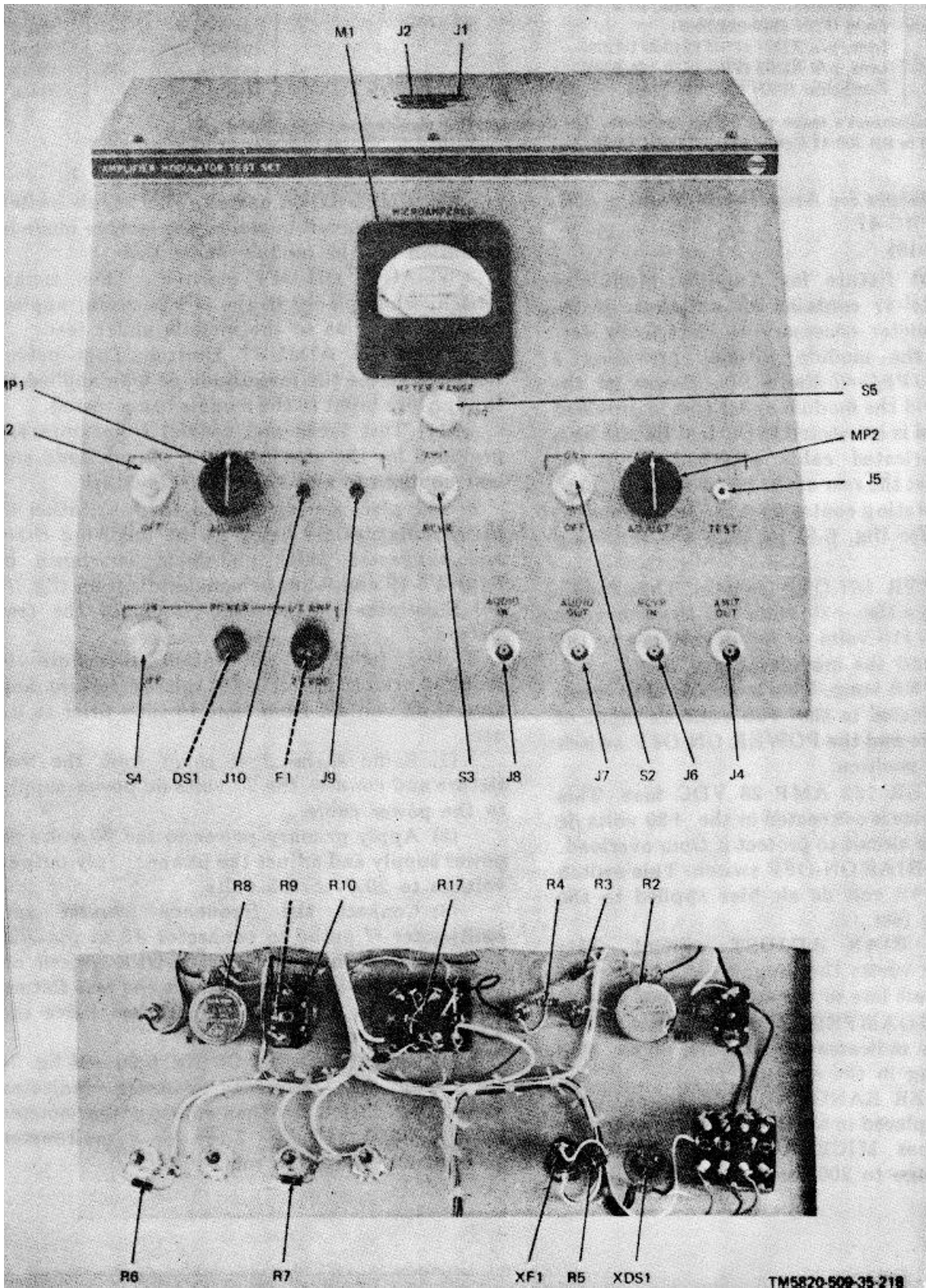

Figure 6-19. Test Fixture for Amplifier-Modulator AM-3507/PRC-47 Parts Location.

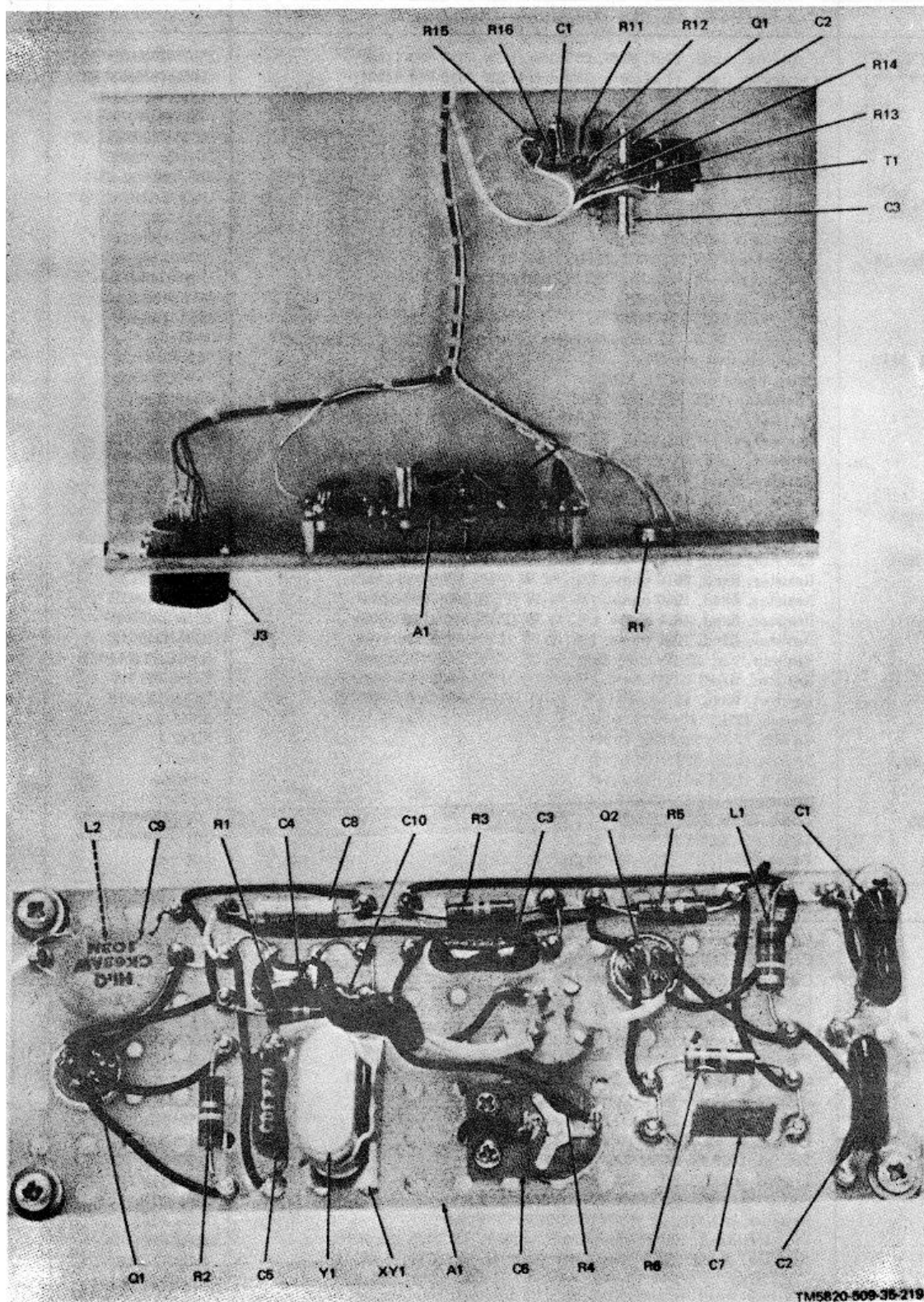

Figure 6-20. Test Fixture for Amplifier-Modulator AM-3507/PRC-47, Chassis Parts and Subassembly A1 Placement.

Symbol	Description	Mfgr Part No.	Mfgr Code
	Test Fixture for Amplifier-Modulator AM-3507/PRC-47		
C1, C2	Capacitor, fixed, 47uf, 20%, 20 vdcw (FSN 5910-800-1130)	150D476X0020R2	56289
C3	Capacitor, fixed, 47 uf 20%, 35 vdcw (FSN 5910-834-8493)	150D476X0035S2	56289
DS1	Lamp (FSN 6240-059-5349)	MS25237-327- 15	
F1	Fuse (FSN 5920-281-t)224)	F02A250V1 -2AS	
J1	Connector (FSN 5935-089-1165)	DBMF13W3S	71468
J2	Connector (FSN 5935-983-2615ZB)	DNMF7W2S	71468
J3	Connector	MS3102A24-28P	
J4	Connector (FSN 5935-755-2,741)	UG912AU	
J5	Contact, p/o J4 (FSN 5935-021-2118)	DM53743-5058	91146
J6 thru J8	Jack (FSN 5935-6t71-5689)	MS16108-8A	
	Connector (FSN 5935-755-2741)	UG912AU	
J9	Contact, p/o J6 thru J8 (FSN 5935-02H2118)	DM53743-5058	91146
J10	Jack (FSN 5935-577-2326)	MS16108-3A	
M1	Jack (FSN 5935-578-3489)	MS16108-2A	
MP1, MP2	Ammeter, DC 0 - 50 microamperes	3860	55026
	Knob, pointer, p/o S3	757-0230-003	13499
	Skirt, knob, p/o MP1, MP2	757-0220-003	13499
Q1	Transistor (FSN 5961-808-7498)	2N1038	
R1	Resistor, var. 1000 ohms, 5%, 3A W (FSN 5905-717-5884)	RT12C2P102	
R2	Resistor, var. 1 Megohm, 10%, 2 W	RV4NAYS105A	
R3	Resistor, fixed, 30,000 ohms 5%, 1/2 W (FSN 5905-192-3978)	RC20GF303J	
R4	Resistor, fixed, 47,000 ohms 10% 1/2 W (FSN 5905-295-3410)	RC20GF473K	
R5	Resistor, fixed, 68 ohms, 5% 1/2 W (FSN 5905-195-5571)	RC20GF680J	
R6, R7	Resistor, fixed, 1000 ohms, 10%, 1/2 W	RC20GF102R	
R8	Resistor, var. 10,000 ohms, 10% 2 W	RV4NAYS103A	
R9, R10	Resistor, fixed, 22,000 ohms, 10% 1/2 W (FSN 5905-171-2004)	RC20GF223K	
R11	Resistor, fixed, 2610 ohms, 1%, 1/4 W (FSN 5905-068-1538)	RN60D2611F	81349
R12	Resistor, fixed, 1960 ohms, 1 % 1/4 W (FSN 5905-069-3914)	RN60D1961F	81349
R13	Resistor, fixed, .46.4 ohms, 1%, 1/4 W (FSN 5905-069-3908)	RN60D46R4F	81349
R14	Resistor, fixed, 1000 ohms, 1%, % W (FSN 5095-883-91981)	RN65D 1001 F	81349
R15	Resistor, var. 1000 ohms, 20%, 1/2 W (FSN 5905-502-3156)	RV6LAYS102B	
R16	Resistor, fixed, 6190 ohms, 1%, 1/4 W (FSN 5905-984-7682CX)	RN60D6191F	81349
R17	Resistor, fixed, 68 ohms, 10%, 1/4 W (FSN 5905-726-6836NT)	RC07GF680K	81349
S1	Switch, (FSN 5930-655-1514)	ST42A	
S2	Switch, (FSN 5930-229-3390)	ST42D	
S3, S4	Switch, (FSN 5293-108-6744)	7665K4	
S5	Switch, (FSN 5930-655- 1514)	ST42A	
T1	Transformer (FSN 5950-812-0292ZX)	A12425	70674
XDS1	Light, (FSN 6210-825-2051)	101-3830-9	72619
	Lens, p/o XDS1 (FSN 6210-511-8208)	101-972	72619
XF1	Fuseholder (FSN 5920-284-7144)	HKPH	71400
A1	Oscillator Assembly	768-7834-001	13499
C1	Capacitor, fixed, 3300 pf, 5%, 500 vdcw	CM06F332J03	
C2	Capacitor, fixed, 4700 pf, 5% 500 vdcw	CM06F472J03	
C3	Capacitor, fixed, 1000 pf, 5% 500 vdcw	CM06F102J03	
C4	Capacitor, fixed, 390 pf, 5%, 500 vdcw	CM05F391J03	
C5	Capacitor, fixed, 820 pf, 5%, 500 vdcw	CM06F821J03	
C6	Capacitor, var. 8 to 50 pf, 500 vdcw	503001E2P034R	72982
C7	Capacitor, fixed, 0.33 uf, P80M20%, 25 vdcw		56289
C8	Capacitor, fixed, 4.7 uf, 20%, 35 vdcw (FSN 5910-542-7387)	150D475X0035B2	56289
C9	Capacitor, fixed, 10,000 pf, 20% 500 vdcw	CK63AW 103M	
C10	Capacitor, fixed, 1000 pf, 5%, 500 vdcw	CM06F102J03	
L1	Coil, rf, 47 uh (FSN 5950-842-2245)	MS90538-04	
L2	Coil, rf, 1000 uh (FSN 5950-060-9188)	MS90539-15	
Q1, Q2	Transistor (FSN 5960-809-1870)	2N 1285	
	Socket, p/o Q1, Q2 (FSN 5935-759-5852CX)	05-3307-51	91662
	Retainer, p/o Q1, Q2 (FSN 5935-523-1777E222)	0004-7202S	91662
R1	Resistor, fixed, 10,000 ohms, 10% 1/2 W (FSN 5905-185-8518)	RC20GF103K	
R2	Resistor, fixed, 0.10 Megohm, 10% 1/2 W- (FSN 5905-192 3987CA)	RC20GF104K	
R3	Resistor, fixed, 10,000 ohms, 10% 1/2 W (FSN 5905-185-8518,	RC07GF103K	
R4	Resistor, var. 1000 ohms, 20 %, 1/2 W (FSN 5905-502-3 156)	RV6LAYS102B	

Symbol	Description	Mfgr Part No.	Mfgr Code
R5 R6 Y1 XY1	Resistor, fixed, 10,000 ohms, 10%, 1/2 W (FSN 5905-185-8518) Resistor, fixed, 3300 ohms, 10%, 1/2 W (FSN 5905-195-6502) Crystal Unit, Quartz, 500.000 kHz (FSN 5955-892-3210) Socket (FSN 5935-201 7119)	RC20GF103K RC20GF332K CR46AU500-00KC TS0205CO1	

Note. All manufacturer's codes are 5-digit numbers. The corresponding manufacturer's name and address are listed in SB 708-42 Catalog Handbook (H4-2).

**6-19. Test Fixture for Signal Data Translator
CV-1377A/PRC-47
(fig. 7-17)**

a. The test fixture for Signal Data Translator CV-1377A/PRC-47 contains all switches, jacks, and lamps necessary to electrically test and adjust the module without providing a complete AN/PRC-47 Radio Set. Indexing fixture (fig. 6-7) is attached to the coupling end of the module to permit accurate indexing of the bandswitch and the slug rack during maintenance procedures. Power for the test fixture and the module under test is provided externally and is connected to the test fixture by a specially fabricated cable attached to power connector J5 at the rear of the test fixture.

b. The operating controls on the front panel of the test fixture (fig. 6-6) perform the following functions:

(1) POWER ON -OFF switch. This toggle switch controls the 115 volts, 400 Hz ac, the +19.5 volts dc, and the +26.5 volts dc input voltages to the test fixture and the module under test.

(2) POWER lamp. This indicator is lit when power is connected to the 115 volts, 400 Hz primary power circuit and the POWER ON-OFF switch is in the ON position.

(3) POWER 115 VAC 1/4 AMP fuse. This protective device is connected to the 115 volts, 400 Hz primary power circuit to protect it from overload.

(4) POWER 19 VDC 1/2 AMP fuse. This protective device is connected to the +19.5 volts dc primary power circuit to protect it from overload.

(5) POWER 6.3 VAC 1 AM P fuse. This protective device is connected to the secondary winding of transformer T1 and protects this 6.3 volts winding from overload.

(6) POWER 26.5 VDC 1 AMP fuse. This protective device is connected in the +26.5 volts primary power circuit to protect it from overload.

(7) AVC ON-OFF switch. This toggle switch selects a variable negative bias for the avc circuits when placed in the ON position.

(8) FUNCTION SEL RCVR-XMIT switch. This toggle switch selects the receive or transmit mode for the module under test.

(9) ERROR B ADJ control. This potentiometer controls the level of external error voltage B.

(10) ERROR A ADJ control. This potentiometer controls the level of external error voltage A.

(11) LOOP SEL OPEN-CLOSED switch. This toggle switch selects external error voltages A and B in the OPEN position to permit calibration of the CV-1377A/PRC-47 master Oscillator. In the CLOSED position, the error voltages generated by the C-4311/PRC-47 are applied to the master oscillator.

(12) OSC CONTROL S1 switch. This rotary switch selects the proper crystal for operation with oscillator Q20.

(13) OSC CONTROL S2 switch. This rotary switch selects the proper crystal for operation with oscillator Q21.

(14) Test jacks and binding posts are provided for the attachment of signal leads and test equipment and are self-explanatory.

c. The piece parts required for fabrication of the test fixture are listed in the following chart and suggested parts placement is shown in figures 6-21 through 6-23 inclusive. Schematic diagram (fig. 7-17) illustrates the internal circuit of the test fixture.

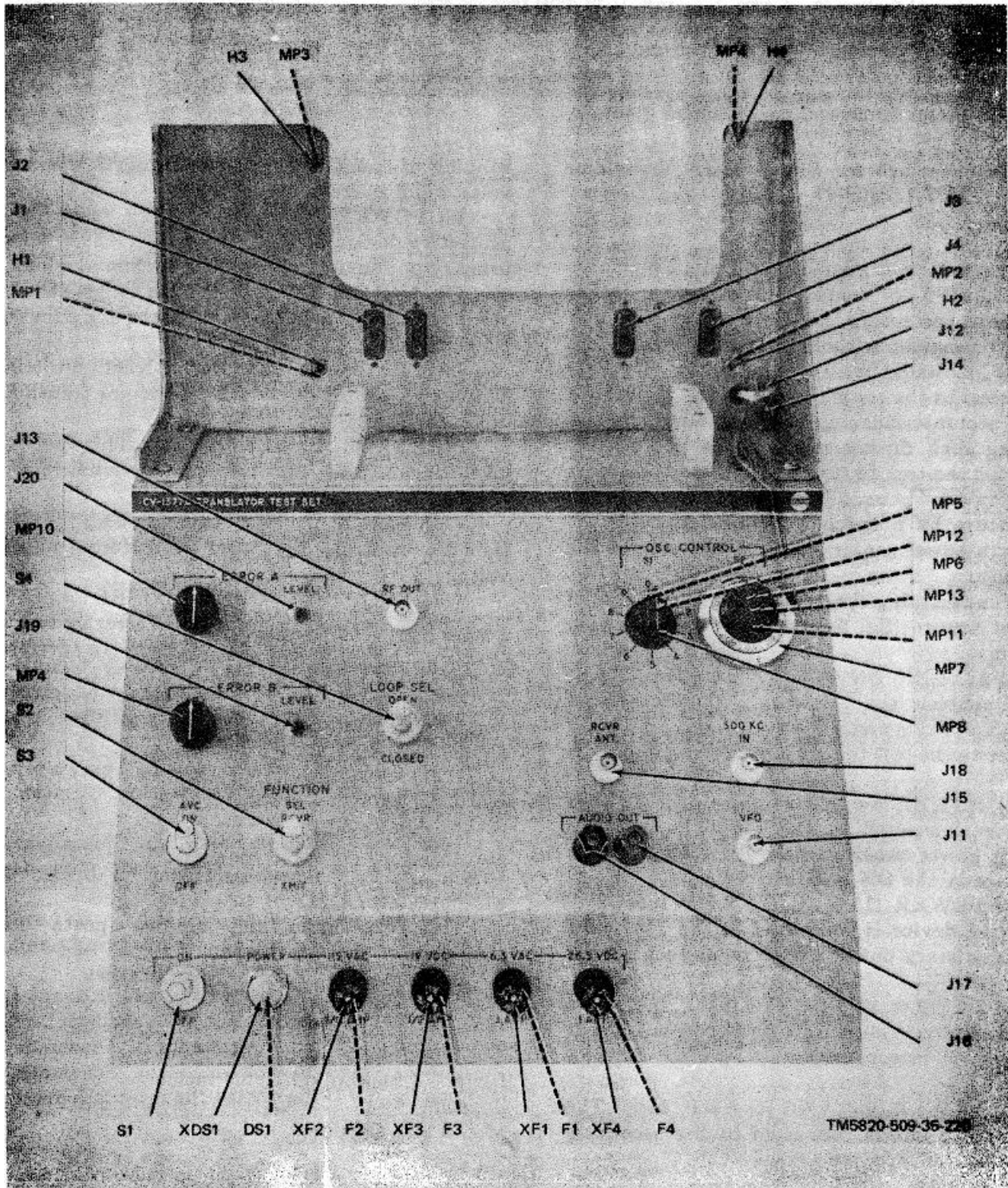

Figure 6-21. Test Fixture for Signal Data Translator CV-1377A/PRC-47, Front View, Parts Location.

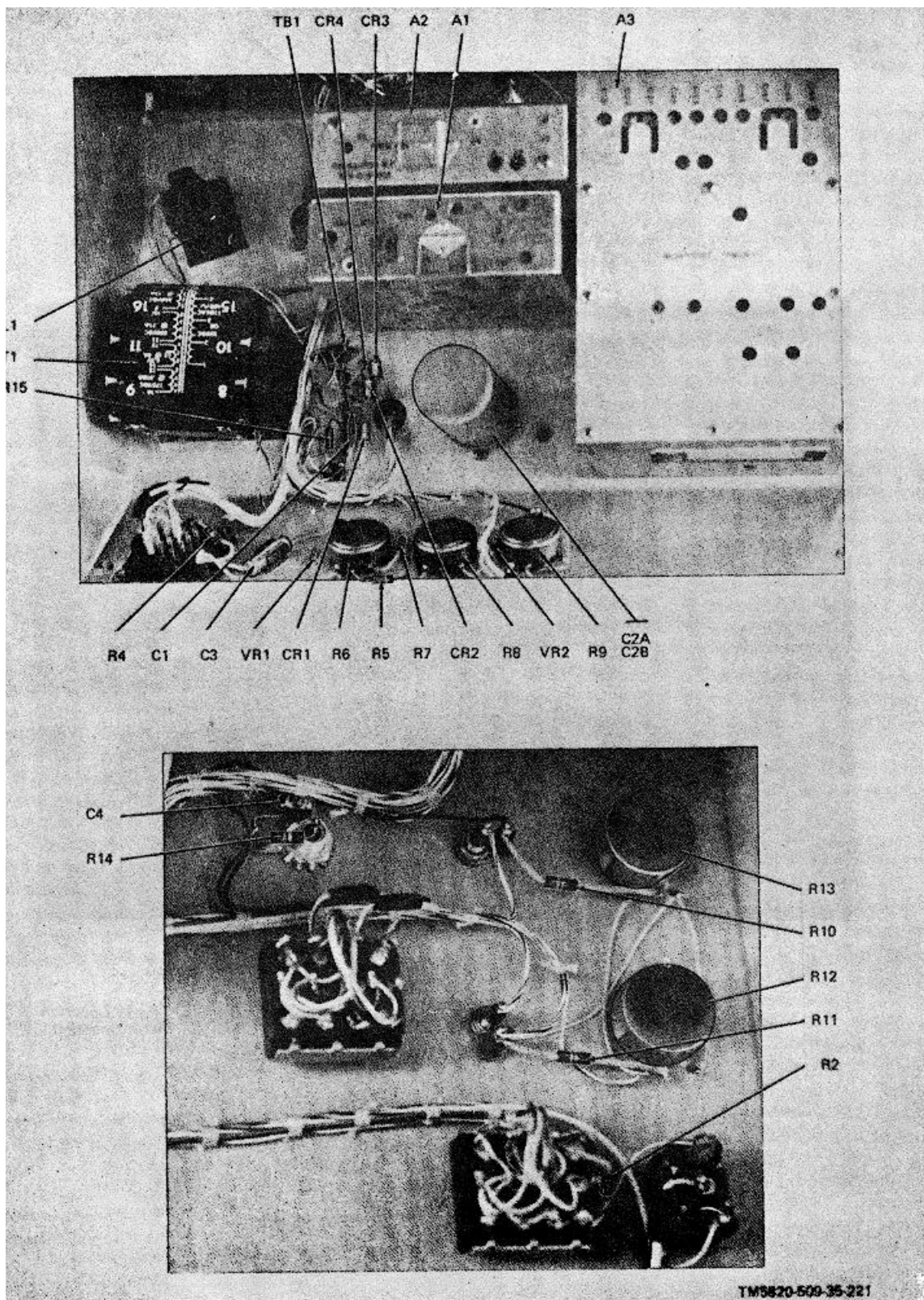

Figure 6-22. Test Fixture for Signal Data Translator CV-1377A/PRC-47, Parts Location.

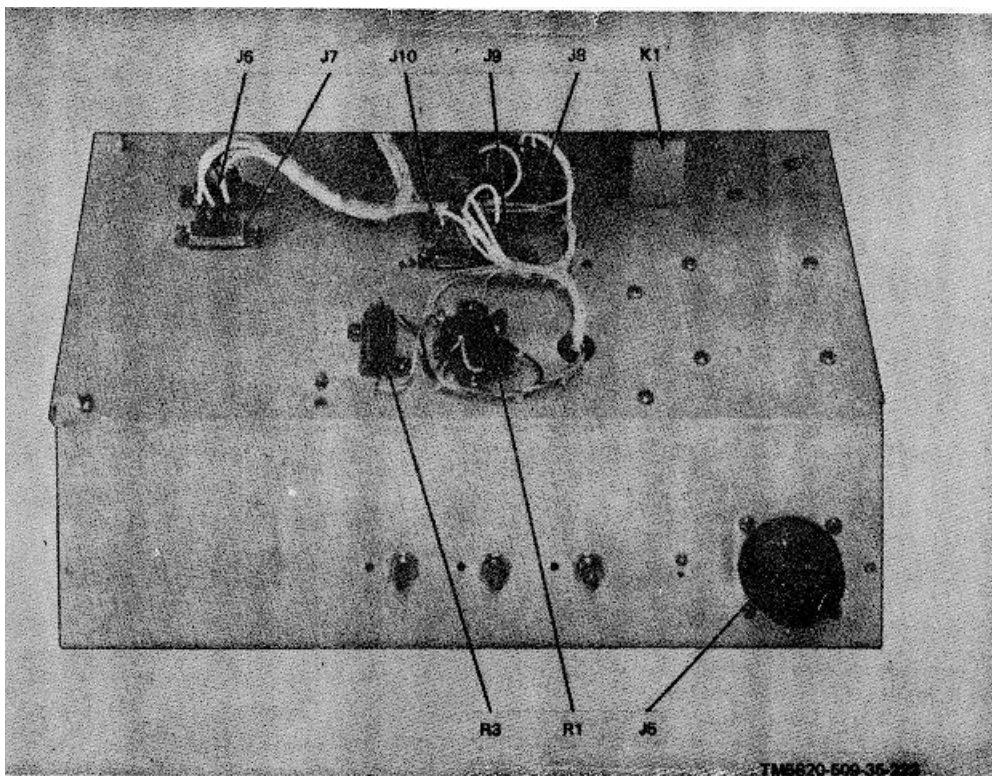

Figure 6-23. Test Fixture for Signal Data Translator CV-1377A/PRC-47, Parts Location.

Symbol	Description	Mfgr Part No.	Mfgr Code
	Test Fixture for Signal Data Translator CV-1377A/PRC-47		
C1	Capacitor, fixed, 10,000 pf, 20%, 500 vdcw	CK63AW103M	
C2	Capacitor, fixed, 35 uf, P100M10%, 450 vdcw ((FSN 5910-954-3038)	D42974	56289
C3	Capacitor, fixed, 4 of, 15%, 100 vdcw (FSN 5910-838-5715)	CL21CN040SP3	
C4	Capacitor, fixed, 5.0 + 0.5 pf, 500 vdcw	CC20CH050D	81349
CR1 thru CR4	Semiconductor device, diode /FSN 5961-845-0766)	1N2615	
DS1	Lamp (FSN 6240-682-3411)	NE51H	08806
F1	Fuse (FSN 5920-280-4465)	F02A250V1AS	
F2	Fuse (FSN 5920443-2641)	F02A250V1-4AS	
F3	Fuse (FSN 5920-281-0224)	F02A250V1-2AS	
F4	Fuse (FSN 5920-280 4465)	F02A25CVIAS	
H1, H2	Thumbscrew	761-9648-015	13499
H3, H4	Thumbscrew	761-9648-004	13499
J1 thru J4	Connector /FSN 5935-983-2615ZB)	DAMF7W2S	71468
	Connector p/o J1 thru J4 (FSN 5825-981-1466ZX)	DM53743-5005	71468
	Connector insert p/o J1 thru J4 (FSN 5935480-02fi8)	DM53742-5000	71468
J5	Connector	MS3102A24-28P	
J6	Connector /FSN 5935-983-2615ZB,	DAMF7W2S	71468
	Connector insert p/o J6 (FSN 5935480-0268)	DM53742-5000	71468
J7	Connector (FSN 5936489-6921)	DAMF3W3S	71468
	Connector insert p/o J7 /FSN 5935-080-0268)	DM63742-5000	71468
J8	Connector /FSN 5935-983-2615ZB)	DAMF7W2S	71468
	Connector insert p/o J8 (FSN 59354804268)	DM53742-5000	71468
J9	Connector (FSN 5936 089-1166)	DBMF13W3S	71468
	Connector insert p/o J9 (FSN 5935480-0268)	DM53742-5000	71468
J10	Connector (FSN 5935-983-2615ZB)	DAMF7W2S	71468
J11	Connector (FSN 5935-755-2741)	UC912AU	
J12	Jack /FSN 5935-577-W)	MS16108-5A	
J13	Connector (FSN 6935-755-2741)	UG912AU	
J14	Jack /FSN 5935-577-2337)	MS16108-5A	
J15	Connector /FSN 5935-755-2741)	UC912AU	
J16	Binding post /FSN 5940-556-6194)	DF30BC	58474
J17	Binding post /FSN 5940-356-2493)	DF30RC	58474
J18	Connector /FSN 5985-755-2741)	UC912AU	
J19, J20	Jack /FSN 5935-578-3489)	MS16108-2A	
K1	Relay, armature	22700-18	77523
L1	Reactor, 0.05 H. (FSN 5950-984-2278ZX)	A12408	70674
MP1, MP2	Spring, Helical compression (FSN 5821-506-7304)	340-0001-000	91314
MP3, MP4	Spring, Helical compression (FSN 5340-811-9737)	340-0419-000	91314
MP5, MP6	Coupling, split hub (FSN 5821-510-4843)	540-7421-003	13499
MP7	Dial (FSN 5355-587-6846)	RBC	73138
MP8	Pointer, knob	757-0230-001	13499
	Skirt, knob p/o MP8	757-0220-001	13499
MP9, MP10	Knob, round (FSN 5355-931-1492ZXI)	757-0228-002	13499
MP11	Shaft, str	761-9639-019	13499
MP12, MP13	Clamp, loop (FSN 5821-396-3116)	504-7537-002	13499
R1	Resistor, fixed, 470 ohms, 5%, 3 W (FSN 5905-925-5518ZX)	RW69V471	
R2	Resistor, fixed, 0.33 Megohm, 10%, 1/2 W (FSN 5905-221-5860) 5860)	RC20CF334K	
R3	Resistor, fixed, 4750 ohms, 1%, 15 W (FSN 5905-952-9232)	RE70G4751	
R4	Resistor, fixed, 27,000 ohms, 10%, 1/2 W (FSN 6905-195-6758)	RC20GF273K	
R5	Resistor, fixed, 82,000 ohms, 10%, 1/2 W ((FSN 5905-254-7097)	RC20GF823K	
R6	Resistor, var. 10,000 ohms, 10%, 2 W	RV4NAYS103A	
R7	Resistor, fixed, 15,000 ohms, 10%, * W /FSN 5906-190-8876)	RG20GF153K	
R8	Resistor, var. 10,000 ohms, 10%, 2 W	RV4NAYS103A	
R10, R11	Resistor, fixed, 0.27 Megohm, 10%, 1/2 W (FSN 5905-643 5140)	RC20G F274K	
R12, R13	Resistor, var. 0.25 Megohm, 10%, 2 W	RV4NAYS254	
R14	Resistor, fixed, 27,000 ohms, 10%, 1/2 W (FSN 5905-196-6768)	RC20GF273K	
R15	Resistor, fixed, 6800 ohms, 10%, 1/2 W (FSN 5905-245-00231	RC20CF682K	
S1, S2	Switch (FSN 5293-108-6744)	7665K4	
S3	Switch (FSN 5930-229-3390)	ST42D	
S4	Switch (FSN 5293-108-6744)	7666K4	
TB1	Terminal board	332-14-07-039	71786

Symbol	Description	Mfgr Part No.	Mfgr Code
T1 VR1 VR2	Transformer (FSN 5950-982-3748ZX) Semiconductor device, zener diode 39 v, 5% Semiconductor device, zener diode 6.2 v, 5% (FSN 5960-752-0179)	BC3069 1N975B 1N753A	97315
XDS1 XF1 thru XF4	Lampholder Fuseholder (FSN 5920-284-7144)	95408H935 HKPH	72619 71400

Note. All manufacturer's codes are 5-digit numbers. The corresponding manufacturer's name and address are listed in SB 708-42 Catalog Handbook (H4-2).

6-20. Test Fixture for Power Supply PP-3518/PRC-47 (fig. 7-18)

a. The test fixture for Power Supply PP-3518/PRC-47 contains all switches, jacks, meters, and lamps necessary to electrically test and adjust the module without providing a complete AN/PRC-47 Radio Set. Power for the test fixture and the module under test is provided externally and is connected to the test fixture by a specially fabricated cable attached to power connector J2 at the rear of the test fixture.

b. The operating controls on the front panel of the test fixture (fig. 6-8) perform the following functions:

(1) 115 VAC ON-OFF switch. This toggle switch controls the 115 volts, 400 Hz ac and interlocks the +23 volt dc circuit between the module under test and the test fixture load circuits.

(2) 115 VAC lamp. This indicator is lit when power is connected to the 115 volts, 400 Hz primary power circuit and the 115 VAC ON-OFF switch is in the ON position.

(3) 115 VAC 5 AMP fuse. This protective device is connected to the 115 volts, 400 Hz primary power circuit to protect it from overload.

(4) +23V ON-OFF switch. This toggle switch controls the +23 volts dc primary power circuit and interlocks it with the 115 volts, 400 Hz primary power circuits to prevent both being energized at one time.

(5) +23V lamp. This indicator is lit when power is connected to the +23 volt primary power circuit and the +23V ON-OFF switch is in the ON position.

(6) +23V 15 AMP fuse. This protective device is connected to the +23 volt primary power circuit to protect it from overload.

(7) BLOWER ON-OFF switch. This toggle switch controls the 115 volts, 60 Hz primary power applied to the blower.

(8) BLOWER 60 CPS 1/2 AMP fuse. This protective device is connected to the 115 volts, 60 Hz primary power circuit that energizes the blower motor and protects it from overload.

(9) HV ON-OFF switch. This toggle switch enables the push-to-talk relay (K1) in the power supply module when high voltage output is desired.

(10) VOLTAGE SEL switch. This 9-position rotary switch selects the power supply module circuit to be monitored and connects it to the DC VOLTAGE meter, or the AC VOLTAGE, jacks for measurement. All power supply module outputs can be selected by this switch.

(11) DC VOLTAGE meter. This 0-100 microammeter is used to indicate the several dc output voltages of the power supply module as selected by the VOLTAGE SEL switch.

(12) AC VOLTAGE jacks. These jacks are provided to connect an external ac instrument for measuring the filament voltage output of the power supply module.

c. The piece parts required for fabrication of the test fixture are listed in the following chart and suggested parts placement is shown in figures 6-24 and 6-25. Schematic diagram (fig. 7-18) illustrates the internal circuit of the test fixture.

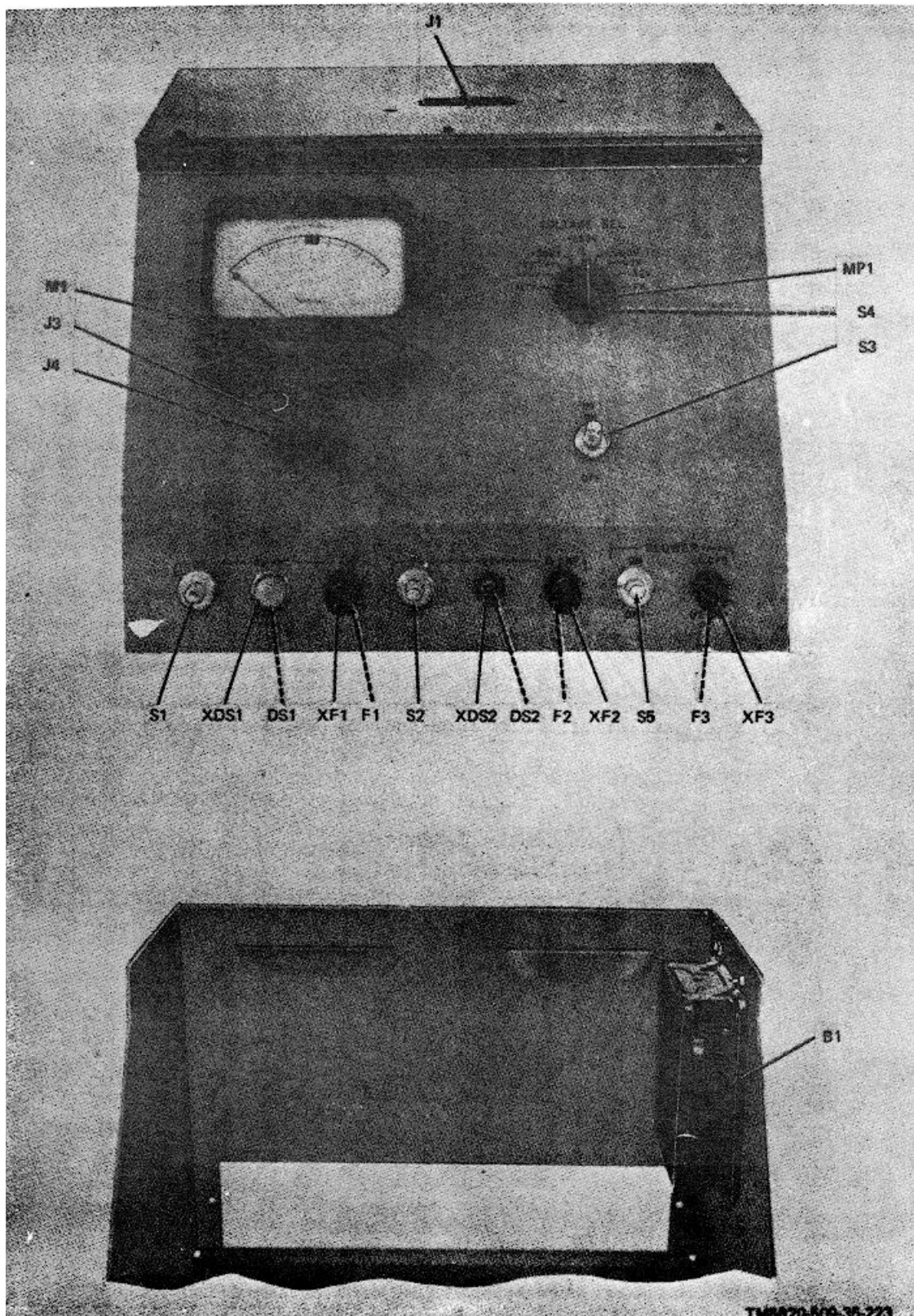

Figure 6-24. Test Fixture for Power Supply PP-3518/PrC-47, Parts Location.

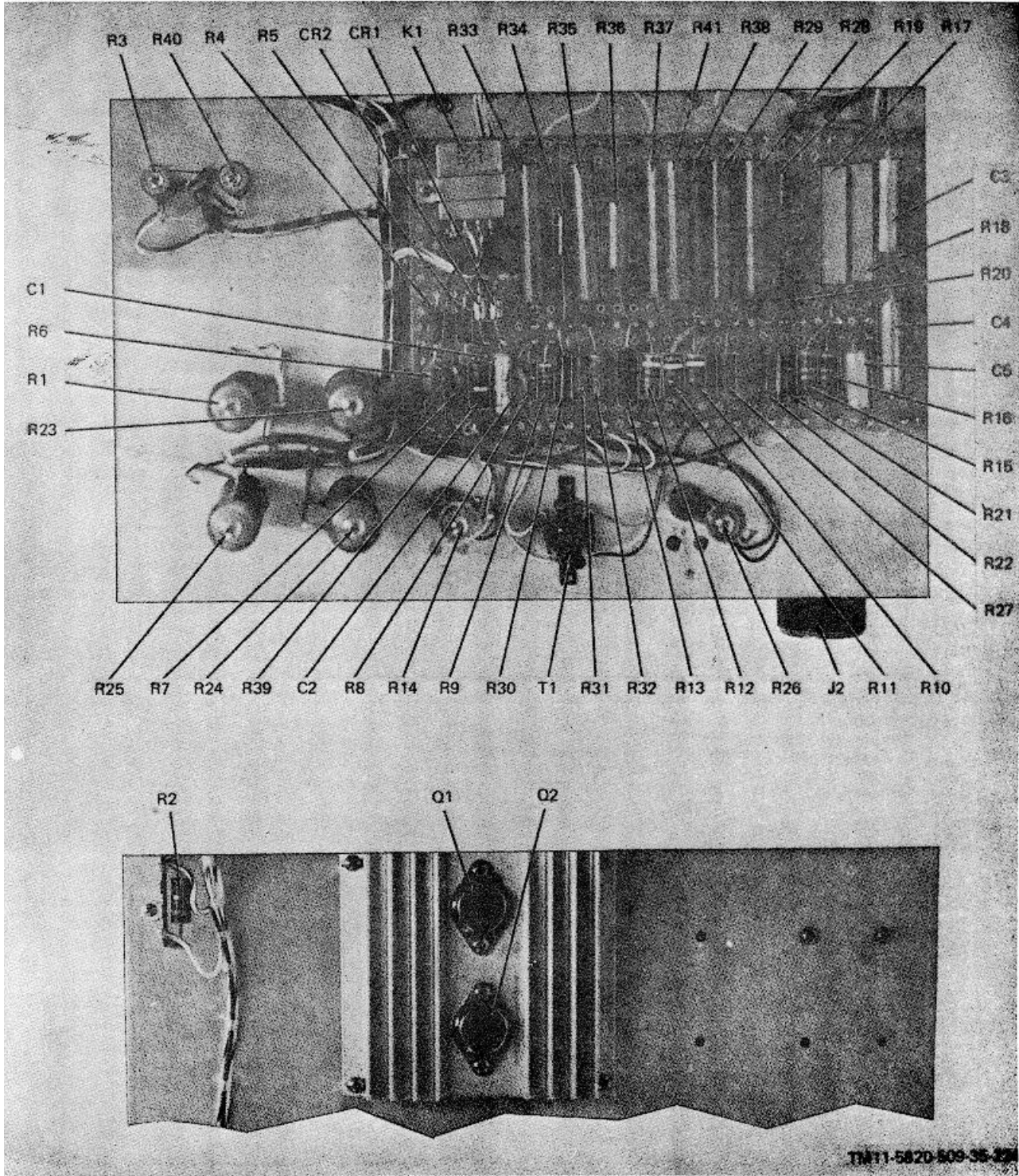

Figure 6-25. Test Fixture for Power Supply PP-3518/PRC-47, Internal Parts Location.

Symbol	Description	Mfgr Part No.	Mfgr Code
	Test Fixture for Power Supply PP-3518/PRC-47		
B1	Blower Assembly	20-244-6502	82877
C1	Capacitor, fixed, 1 uf, 20%, 200 vdcw	610D105M200BD4	56289
C2	Capacitor, fixed, 0.02 uf, P80M20%, 100 vdcw	855-502X5V0203Z	72982
C3, C4	Capacitor, fixed, 0.047 uf, 20%, 600 vdcw	196P47306S4	56289
C5	Capacitor, fixed, 0.047 uf, 20%, 300 vdcw	196P47303S4	56289
CR1, CR2	Semiconductor device, diode (FSN 5961-975-2158)	1N2611	
DS1	Lamp (FSN 6240-682-3411)	NE51H	08806
DS2	Lamp (FSN 6240-196-4491)	330	71744
F1	Fuse	F03B32V5AS	
F2	Fuse	F03B32V15AS	
F3	Fuse (FSN 5920-281-G224)	F02A250VD2AS	
J1	Connector (FSN 5935-045-9104CX)	DCMF27W2S	71468
	Connector insert p/o J1 (FSN 5935-034-1098NT)	DM51155	71468
J2	Connector	MS3102A24-28P	
J3	Binding post (FSN 5940-816-8363)	DF30GNC	58474
	Contact, electrical p/o J3	767-5609-001	13499
J4	Binding post (FSN 5940-556-6194)	DF3OBC	58474
K1	Relay, armature	BR7X300D2S3.26Y	09026
M1	Microammeter, dc ((0.100)	3970	55026
MP1	Knob, pointer	757-0230-003	13499
	Skirt, knob, p/o MP1	757-0220-003	13499
Q1,Q2	Transistor	2N2833	
	Heatsink, D/O Q1, Q2	775-9212-001	13499
R1	Resistor, fixed, 1.5 ohms, 5%, 55 W	RW35V1R5	
R2	Resistor, fixed, 130 ohms, 5%, 2 W (FSN 5905-279-2825)	RC42GF131J	
R3	Resistor, fixed, 100 ohms, 5%, 14 W (FSN 5905-258-6925)	RW31V101	
R4, R5	Resistor, fixed, 6.8 ohms, 5%, 3 W (FSN 5905-990-4151)	RW69V6R8	
R6, R7	Resistor, fixed, 470 ohms, 5%, 6.5 W (FSN 5905-985-5401)	RW67V471	
R8	Resistor, fixed, 0.22 Megohm, 5%, 1 W (FSN 5905-299-2000)	RC32GF224J	
R9	Resistor, fixed, 47,000 ohms, 5%, 1 W (FSN 5905-299-2013)	RC32GF473J	
R10 thru R12	Resistor, fixed, 390 ohms, 5%, 2 W (FSN 5905-253-1231)	RC42GF391J	
R13	Resistor, fixed, 270 ohms, 5%, 6.5 W (FSN 5905-780-7488ZX)	RW67V271	
R14	Resistor, fixed, 6800 ohms, 5%, 26 W	RW33V682	
R15	Resistor, fixed, 30,000 ohms, 5%, 2 W (FSN 5905-171-1977)	RC42GF303J	
R16	Resistor, fixed, 36,000 ohms, 5%, 2 W (FSN 5905-185-6570)	RC42GF363J	
R17, R18	Resistor, fixed, 25,000 ohms, 10%, 10W (FSN 5905-90D5901)	710-9068-000	11502
R19 thru R22	Resistor, fixed, 1 Megohm, 2%, 2W	RL42S105G	
R23 thru R25	Resistor, fixed, 5600 ohms, 10%, 55 W	RW35V562	
R26	Resistor, fixed, 1200 ohms, 5%, 26 W	RW33V122	
R27	Resistor, fixed, 0.649 Megohm, 1%, 3/4 W	RN70D6493F	
R28	Resistor, fixed, 1.21 Megohm, 1%, 2 W	RN80B1214F	
R29	Resistor, fixed, 1 Megohm, 1% 2 W (FSN 5905-557 1951)	RN80B1004F	
R30	Resistor, fixed, 0.383 Megohm, 1% (FSN 5905-726-7545)	RN70C3833F	
R31	Resistor, fixed, 0.464 Megohm, 1% 1/2 W (FSN 5905-752-3605)	RN70C4643F	
R32	Resistor, fixed, 0.536 Megohm, 1% 3/4 W	RN70D5363F	
R33	Resistor, fixed, 4.99 Megohm, 1%, 2 W (FSN 5905-553-2223)	RN80B4994F	
R34	Resistor, fixed, 1 Megohm, 1%, 2W (FSN 5905-702-3359)	HN70C1004F	
R35	Resistor, fixed, 10 Megohm, 1% 2 W (FSN 5905-553-2402)	RN80B1005F	
R36	Resistor, fixed, 3.48 Megohm, 1%, 1 W (FSN 5905-552-6066)	RN75B3484F	
R37	Resistor, fixed, 4.99 Megohm, 1%, 2 W (FSN 5905-553-2223)	RN80B4994F	
R38	Resistor, fixed, 2.49 Megohm, 1%, 2 W	RN80B2494F	
R39	Resistor, fixed, 5600 ohms, 10%, 2 W (FSN 5905-279-2303)	RC42GF562K	
R40	Resistor, fixed, 100 ohms, 5%, 14 W (FSN 5905 258 6924)	RW31V101	
R41	Resistor, fixed, 10 Megohm, 1%, 2 W (FSN 5905-553-2402,	RN80B1005F	
S1, S2	Switch (FSN 5293-108-6744)	7665K4	
S3	Switch (FSN 5930-655-1514)	ST42A	
S4	Switch	JV9008	71590
S5	Switch (FSN 5930 655-1514)	ST42A	
T1	Transformer (FSN 5950-984 1 IIIZX))	BC3072	97315
XDS1	Lampholder	96408H935	72619
XDS2	LIGHT (FSN 6210-825-2051)	101-3830-9	72619
	Lens p/o XDS2 (FSN 6210-.511-8208)	101-972	72619
XF1 thru XF3	Fuseholder (FSN .5920-284- 7144)	HKPH	71400

Note. All manufacturer s codes are 5-digit numbers. The corresponding manufacturer's name and address are listed in SB 708-42 Catalog Handbook ((H4-2).

**6-21. Test Fixture for Radio Frequency
Oscillator 0-1032/PRC-47**
(fig. 7-19)

a. The test fixture for Radio Frequency Oscillator 0-1032JPRC-47 contains all switches, jacks, meter and lamps necessary to electrically test and adjust the module without providing a complete AN/PRC-47 Radio Set. Power for the test fixture and the module under test is provided externally and is connected to the test fixture by a specially fabricated cable attached to power connector J2 at the rear of the test fixture.

b. The operating controls on the front panel of the test fixture (fig. 6-9) perform the following functions:

(1) +20V ON-OFF switch. This toggle switch controls the +20 volts dc primary power circuit to the module under test.

(2) +20V lamp. This indicator is lit when power is connected to the +20 volts dc primary power

circuit and the +20V ON-OFF switch is in the ON position.

(3) +20V 1/4 AMP fuse. This protective device is connected to the +20 volts dc primary power circuit to protect it from overload.

(4) +20 V CURRENT meter. This 0 - 60 milliammeter indicates the amount of current being drawn by the module under test.

(5) PUSH TO READ button. This shunting switch is opened when pressed to permit the +20 V CURRENT meter to indicate the module current drain.

(6) Coaxial connectors are provided for the connection of signal leads and test equipment and these are self-explanatory.

c. The piece parts required for fabrication of the test fixture are listed in the following chart and suggested parts placement is shown in figure 6-26. Schematic diagram {fig. 7-19) illustrates the internal circuit of the test fixture.

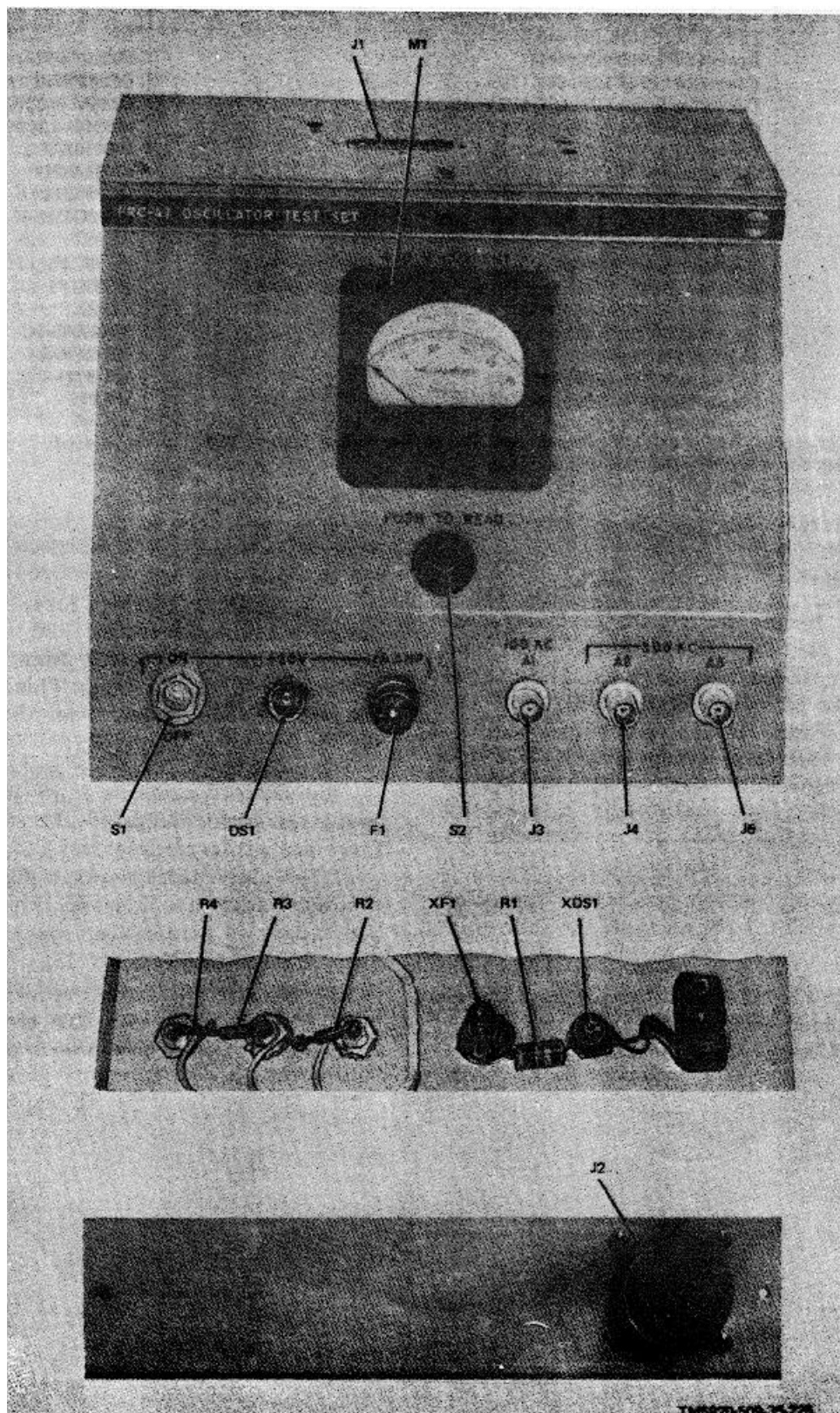

Figure 6-26. Test Fixture for Radio Frequency Oscillator O-1032/PRC-47, Parts location.

Symbol	Description	Mfgr Part No.	Mfgr Code
	Test Set for Radio Frequency Oscillator O-1032/PHC-47		
DS1	Lamp (FSN 6240-196-4491)	330	08805
F1	Fuse (FSN 5920-043-2641)	F02A250V1 -4AS	
J1	Connector (FSN 5935-089-1165)	DBMF13W3S	71468
	Connector insert p/o J1 (FSN 5935-080-0268)	DM53742-5000	71468
J2	Connector	MS3102A24-28P	
J3 thru J5	Connector (FSN 5935-755-2741)	UG912AU	
M1	Milliammeter, 0-50 ma (FSN 6825-643-1527)	M531 -2-214	82386
R1	Resistor fixed, 100 ohms, 10%, 2 W	RC42GFIOIK	
R2	Resistor fixed, 12,000 ohms, 10%, 1/2 W (FSN 5905-1908884AH)	RC20GF123K	
R3	Resistor, fixed, 510 ohms, 5%, 1/2 W (FSN 5906-279-3511)	RC20CF511J	
R4	Resistor, fixed, 1200 ohms, 10%, 1/2 W (FSN 5905-195-6809)	RC20GP122K	
S1	Switch (FSN 5930-855-1514)	ST42A	
S2	Switch (FSN 5930417-7120)	MS25089-5C	
DS1	Light (FSN 6210-825-20511)	101-3830-9	72619
	Lens p/o XDSI (FSN 6210-511 -82081)	101-972	72819
XF1	Fuseholder (FSN 5920-284-71441)	HKPH	71400

Note. All manufacturer 'a codes are 5-digit numbers . The corresponding manufacturer's name and address are listed in SB 708-42 Catalog Handbook (H4-2).

6-22. Test Fixture for Oscillator Control C-4311/PRC-47
(fig. 7-20)

a. The test fissure for Oscillator Control C-4311/PRC-47 contains all switches, jacks and lamps necessary to electrically test and adjust the module without providing a complete AN/PRC-47 Radio Set. Power for the test fissure and the module under test is provided externally and is connected to the test fissure by a specially fabricated cable attached to power connector J4 at the rear of the test fixture.

b. The operating controls on the front panel of the test fixture (fig. 6-10) perform the following functions:

(1) +20V ON-OFF switch. This toggle switch controls the +20 volts dc primary power circuit to the module under test.

(2) +20V lamp. This indicator is lit when power is connected to the +20 volts dc primary power

circuit and the +20V ON-OFF switch is in the ON position.

(3) +20V 1/2 AMP fuse. This protective device is connected to the +20 volts dc primary power circuit to protect it from overload.

(4) ANTI-LOCX lamp. This lamp is lit when the anti-lock dc output from the module under test is present.

(5) Coaxial connectors are provided for the connection of signal leads and test equipment and these are self-explanatory.

c. The piece parts required for fabrication of the test fissure are listed in the following chart and suggested parts placement is shown in figure 6-27. Schematic diagram (fig. 7-20) illustrates the internal circuit of the test fixture.

d. Calibrate the Radio Frequency Oscillator O 1032/PRC-47 used with this test fixture in accordance with the procedures in paragraph 6-14g.

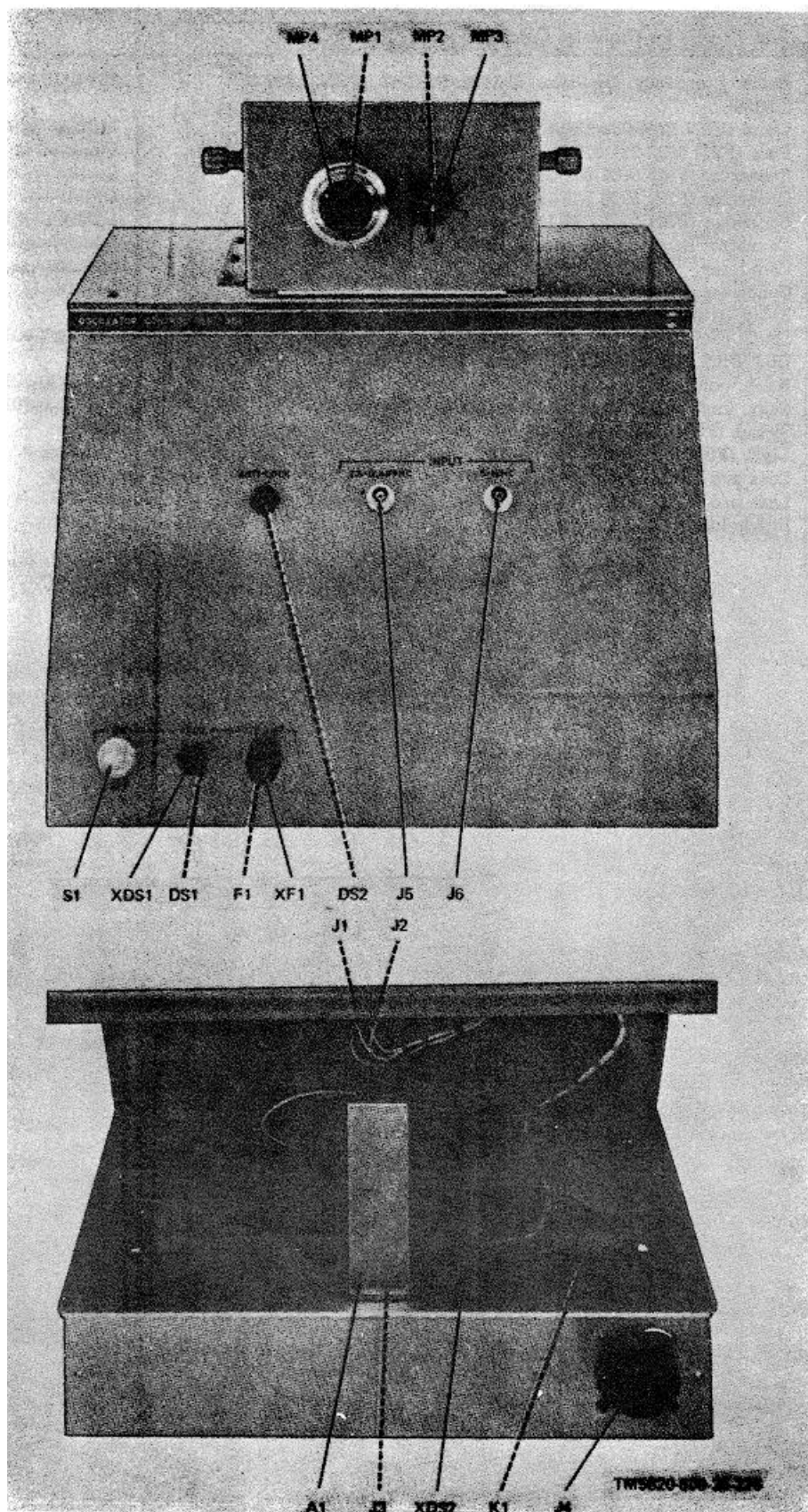

Figure 6-27. Test Fixture for oscillator Control C-4311/PRC-47, Parts Location.

Symbol	Description	Mfgr Part No.	Mfgr Code
	Test Fixture for Oscillator Control C-4311/PRC-47		
A1	Radio Frequency Oscillator 0-1032/PRC-47 (FSN 5820-087-0328)	528 0119 005	13499
DS1, DS2	Lamp (FSN 6240-069 63491)	MS25237-327-15	
F1	Fuse (FSN 5920-281-0224)	F02A250V1-2AS	
J1	Connector /FSN 5935-983-2615ZBI	DAMF7W2S	71468
J2	Connector (FSN 5935-089-69211)	DAMF3W3S	71468
J3	Connector (FSN 5936-089-1166)	DBMF13W3S	71468
J4	Connector insert p/o J1 thru J3 (FSN 5935-080 0268)	DM63742-5000	71468
J5, J6	Connector (FSN 5935-755-2741)	MS3102A24-28P	
K1	Relay, armature (FSN 5945-779 77721)	UG912AU	
MP1, MP2	Shaft, coupling	93591	78277
MP3	Dial (FSN 6366-687 68461)	768-7887-001	13499
MP4	Knob, pointer	RBC	73138
S1	Skirt, knob p/o MP4	757-0230-001	13499
XDS1, XDS2	Switch (FSN 5930-655-1514, Light (FSN 6210-826-20511)	757-0220-001	13499
	Lens p/o XDS1 (FSN 6210-511-82081)	ST42A	
	Lens p/o XDS2 (FSN 6210460-65401)	101-3830-9	72619
XF1	Fuseholder (FSN 5920-284-7144)	101-972	72619
		101-971	72619
		HKPH	71400

CHAPTER 7 CIRCUIT DIAGRAMS

7 1. Introduction

This chapter contains block diagrams, mechanical schematics, main schematic diagrams and test fixture diagrams for Radio Receiver-Transmitter RT 671/PTC-47. The information is assembled in the following order:

- a. MIL standard color codes (fig. 7-1).
- b. Block diagrams (fig. 7-2 through 7-6).

- c. Mechanical schematic (fig. 7-7).
- d. Main schematic diagrams (fig. 7 8 through 7-14).
- e. Test fixture diagrams (fig. 7-15 through 7-20).

All special symbols appearing on these drawings are defined in the notes that are part of the diagrams in which they appear.

**Figure 7-1. Color Code Marking for Military Standard Resistors, Inductor, and Capacitors.
(Located in back of manual.)**

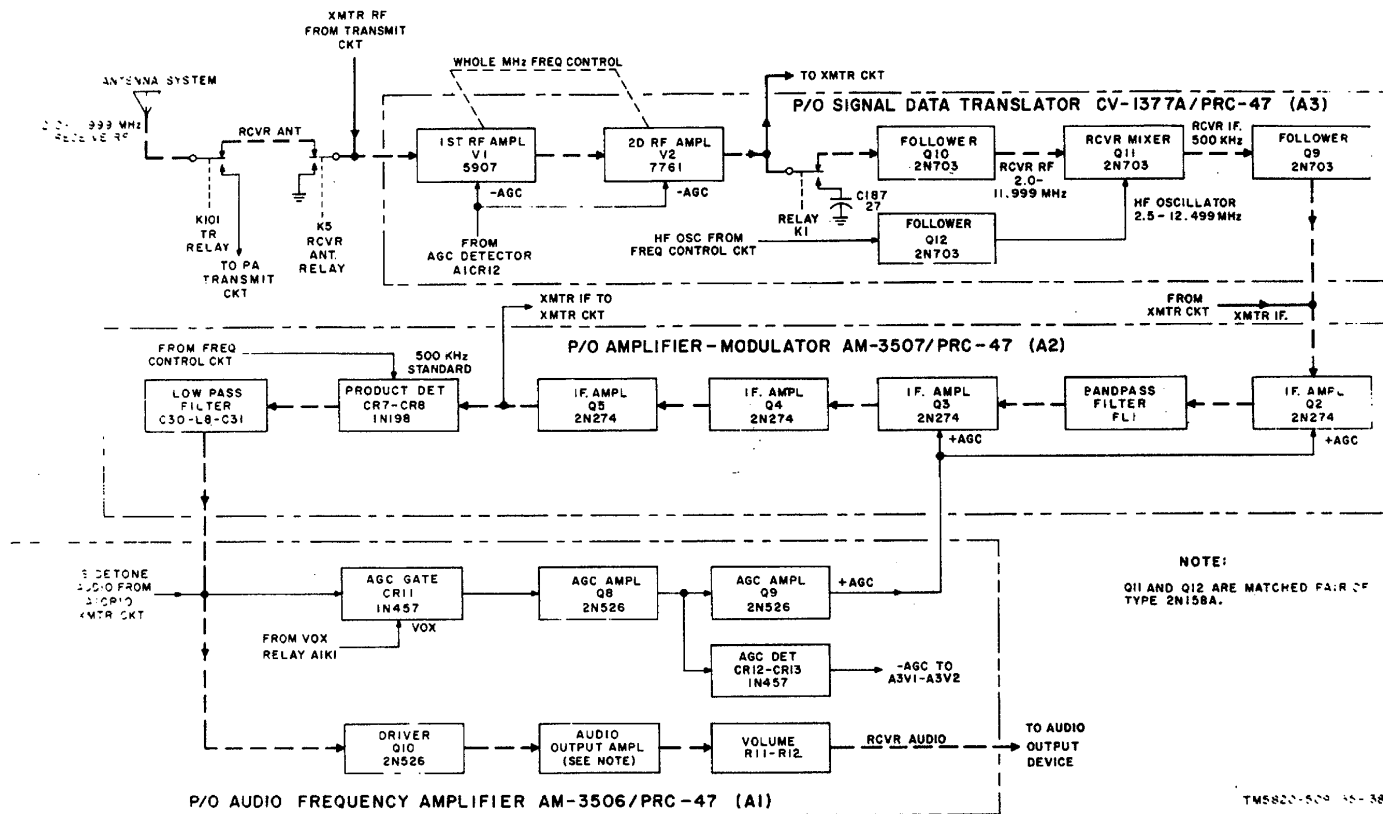

Figure 7-2. Receive Signal Path, Block Diagram.

**Figure 7-3. Transmit Signal Path, Block Diagram.
(Located in back of manual.)**

**Figure 7-4. Frequency Control Circuits, Block Diagram.
(Located in back of manual.)**

**Figure 7-5. Power Supply Circuits, Dc Primary Power Input, Block Diagram.
(Located in back of manual.)**

**Figure 7-6. Power Supply Circuits, Ac Primary Power Input, Block Diagram.
(Located in back of manual.)**

**Figure 7-7. Mechanical Schematic, Frequency Control Mechanism.
(Located in back of manual.)**

**Figure 7-8 (1). Electrical Equipment Chassis CH-474/PRC-47(A8A4), Schematic Diagram (sheet 1 of 2).
(Located in back of manual.)**

**Figure 7-8 (2). Electrical Equipment Chassis CH-474/PRC-47 (A8A4), Schematic Diagram (sheet 2 of 2).
(Located in back of manual.)**

**Figure 7-9. Audio Frequency Amplifier AM-3506/PRC-47(A8A1), Schematic Diagram.
(Located in back of manual.)**

**Figure 7-10. Amplifier-Modulator AM-3507/PRC-47 (A8A2). Schematic Diagram.
(Located in back of manual.)**

**Figure 7-11 (1) . Signal Data Translator CV -1377A/PRC-47 (A8A3), Schematic Diagram (sheet 1 of 2).
(Located in back of manual.)**

**Figure 7-11 (2) Signal Data Translator CV-1377A/PRC-47 (A8A3). Schematic Diagram (sheet 2 of 2).
(Located in back of manual.)**

**Figure 7-12. Power Supply PP-3518/PRC-47 (A8A5), Schematic Diagram.
(Located in back of manual)**

**7-13. Radio Frequency Oscillator O-1032/PRC-47 (A8A6) , Schematic Diagram.
(Located in back of manual.)**

**Figure 7-14. Oscillator Control C-4311/PRC-47 (A8A7), Schematic Diagram.
(Located in back of manual.)**

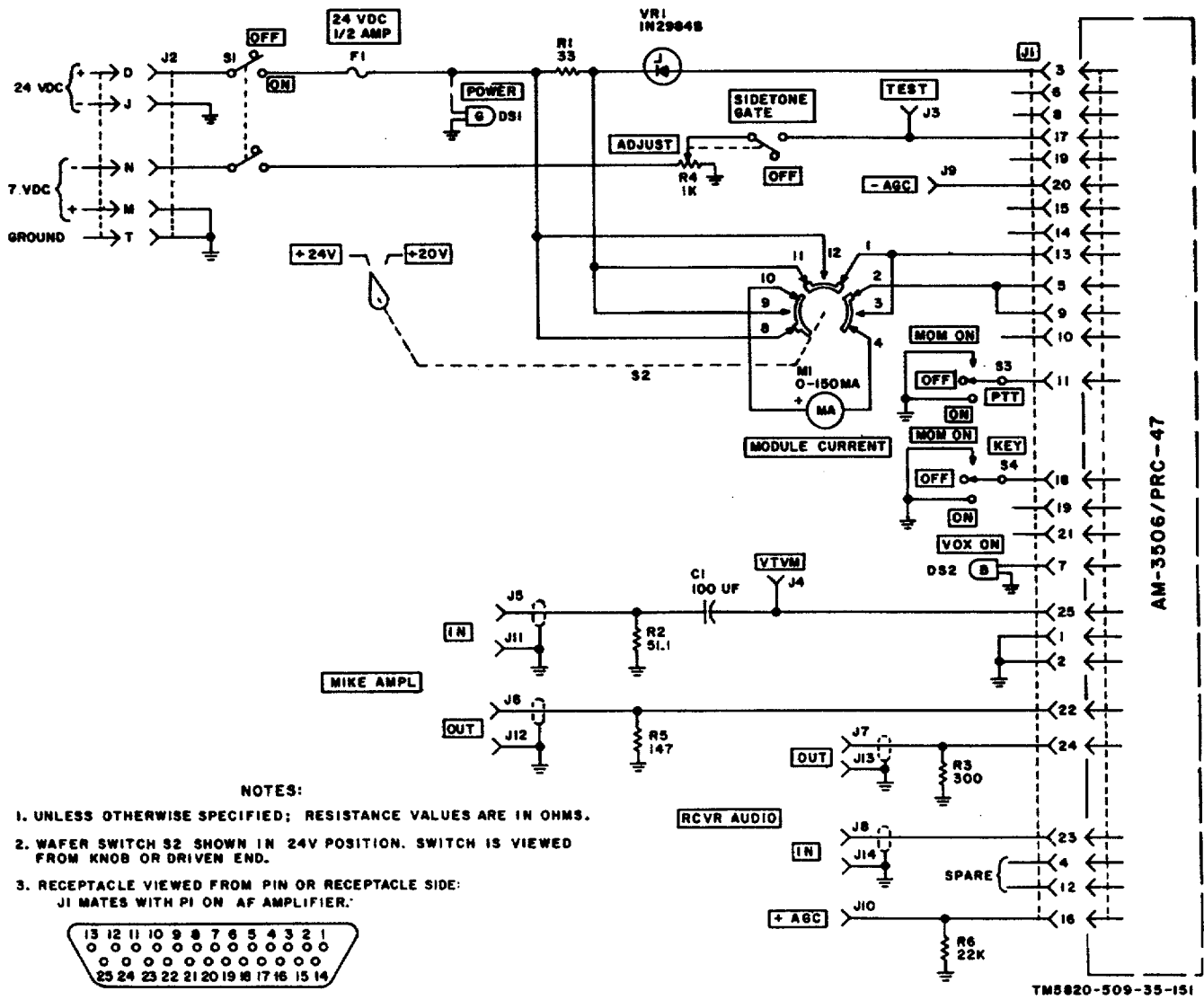

Figure 7-15. Test Fixture for Audio Frequency Amplifier AM-3506/PRC-47, Schematic Diagram.

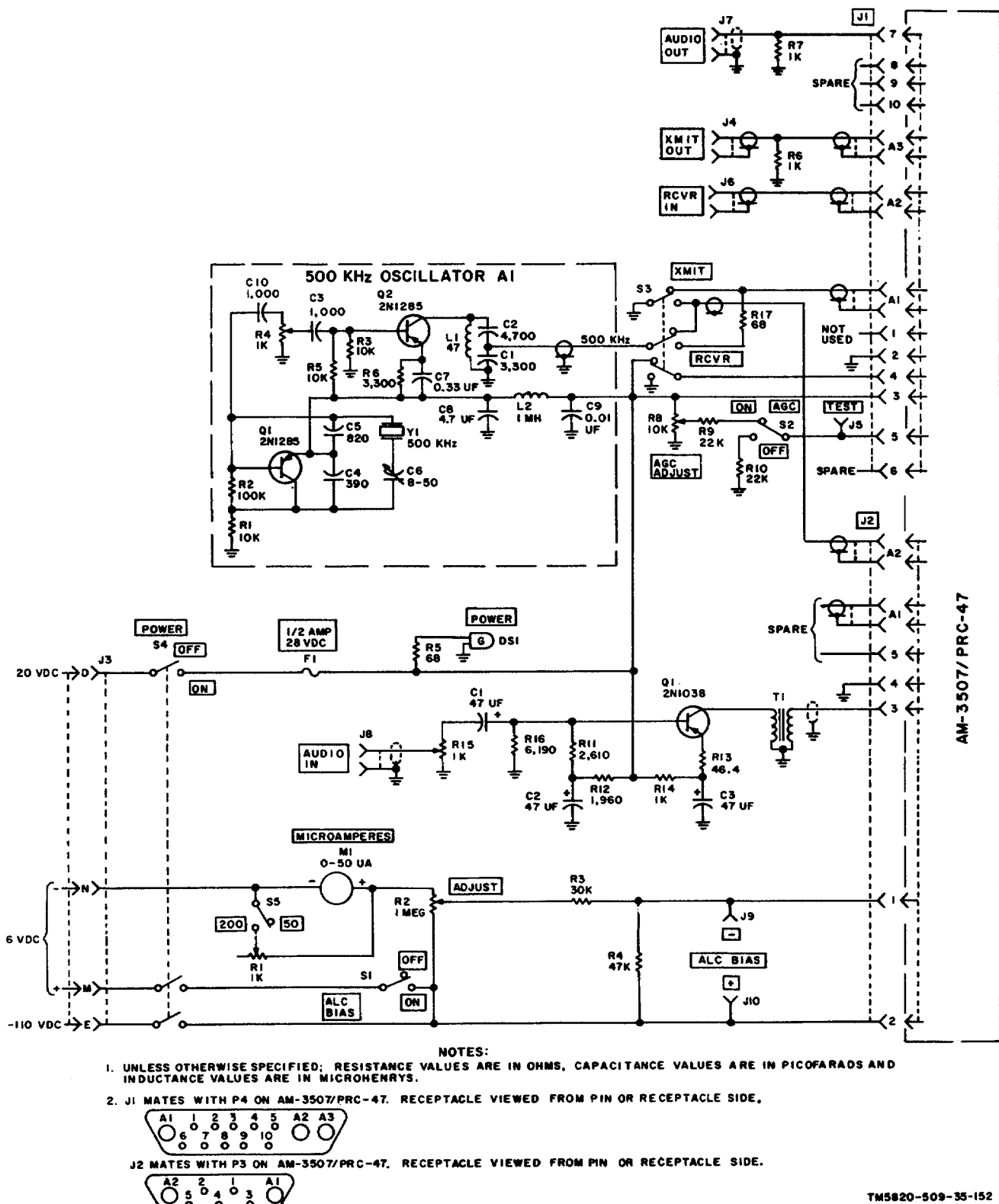
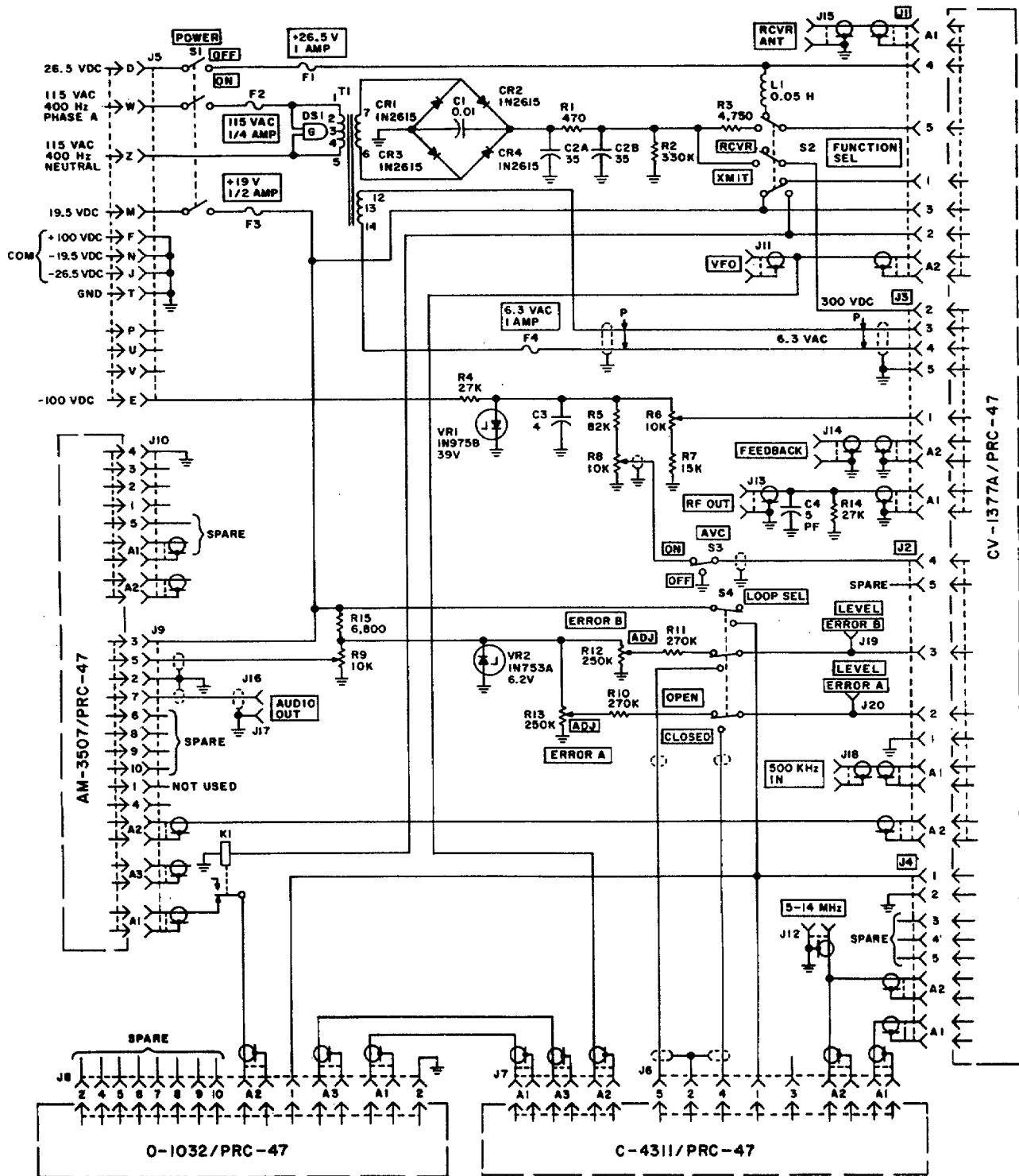

Figure 7-16. Test Fixture for Amplifier-Modulator AM-3507/PRC-47, Schematic Diagram.



- NOTES:**
- UNLESS OTHERWISE SPECIFIED: RESISTANCE VALUES ARE IN OHMS AND CAPACITANCE VALUES ARE IN MICROFARADS.
 - RECEPTACLES VIEWED FROM PIN OR RECEPTACLE SIDE:
 - J1 MATES WITH P1 ON CV-1377A/PRC-47.
 - J2 MATES WITH P2 ON CV-1377A/PRC-47.
 - J3 MATES WITH P3 ON CV-1377A/PRC-47.
 - J4 MATES WITH P4 ON CV-1377A/PRC-47.
 - J6 MATES WITH P1 ON C-4311/PRC-47.
 - J10 MATES WITH P3 ON AM-3507/PRC-47.

- J7 MATES WITH P2 ON C-4311/PRC-47.
- J8 MATES WITH P1 ON O-1032/PRC-47.
- J9 MATES WITH P4 ON AM-3507/PRC-47.

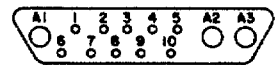
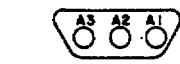
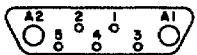

Figure 7-17. Test Fixture for Signal Data Translator CV-1377A/PRC-47, Schematic Diagram.

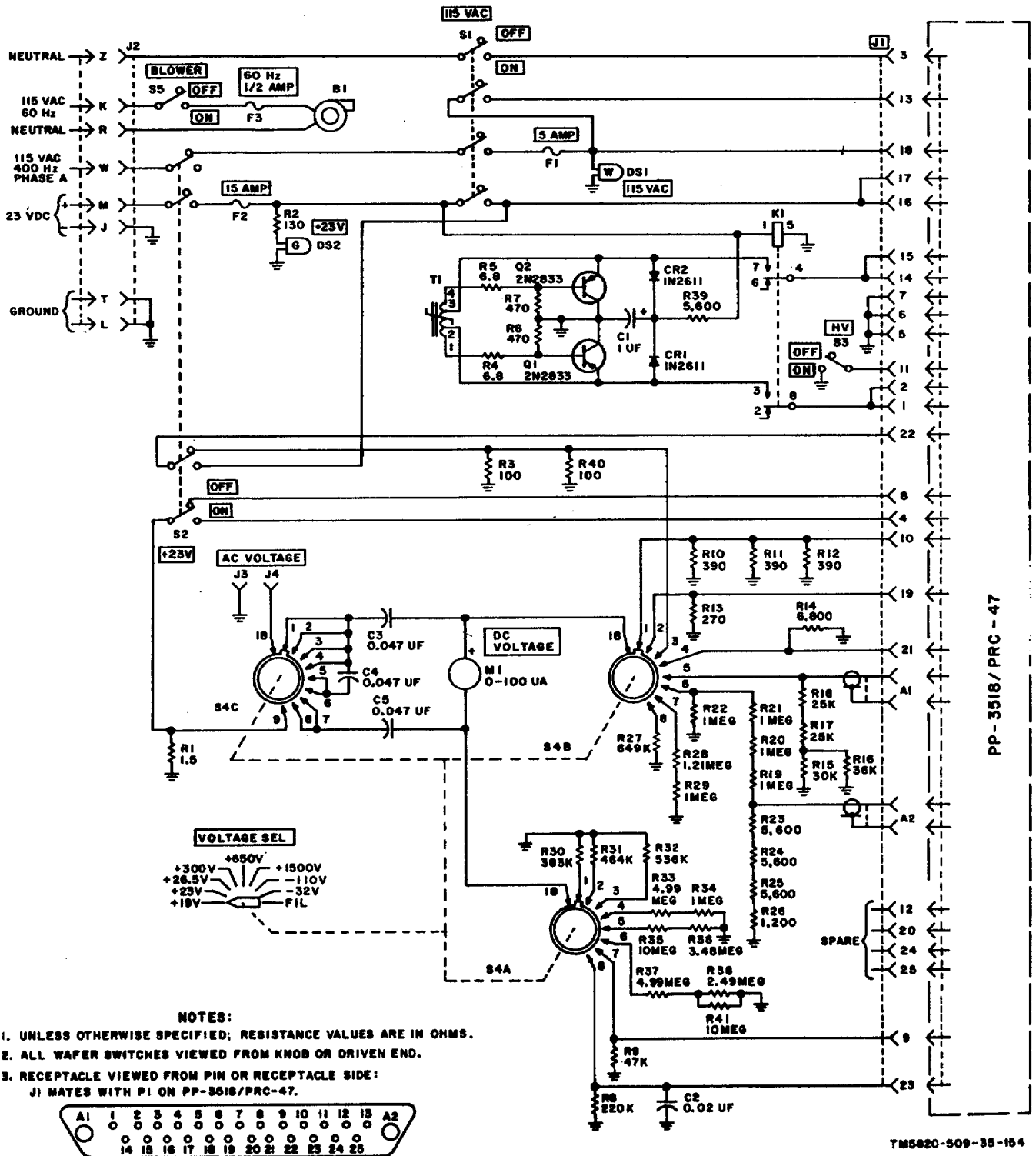
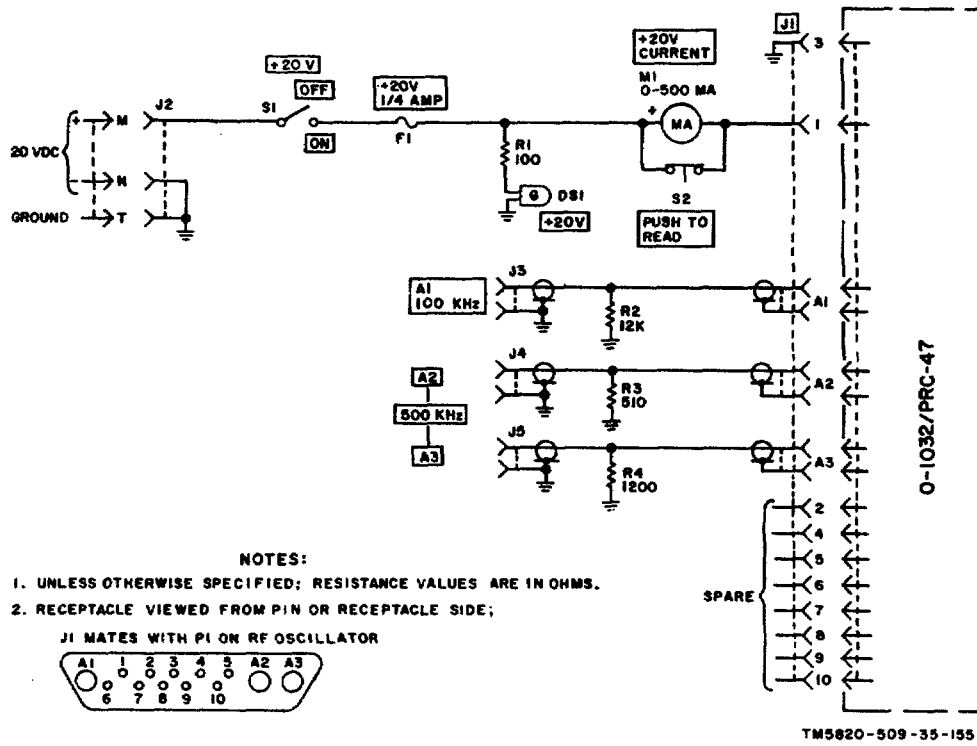
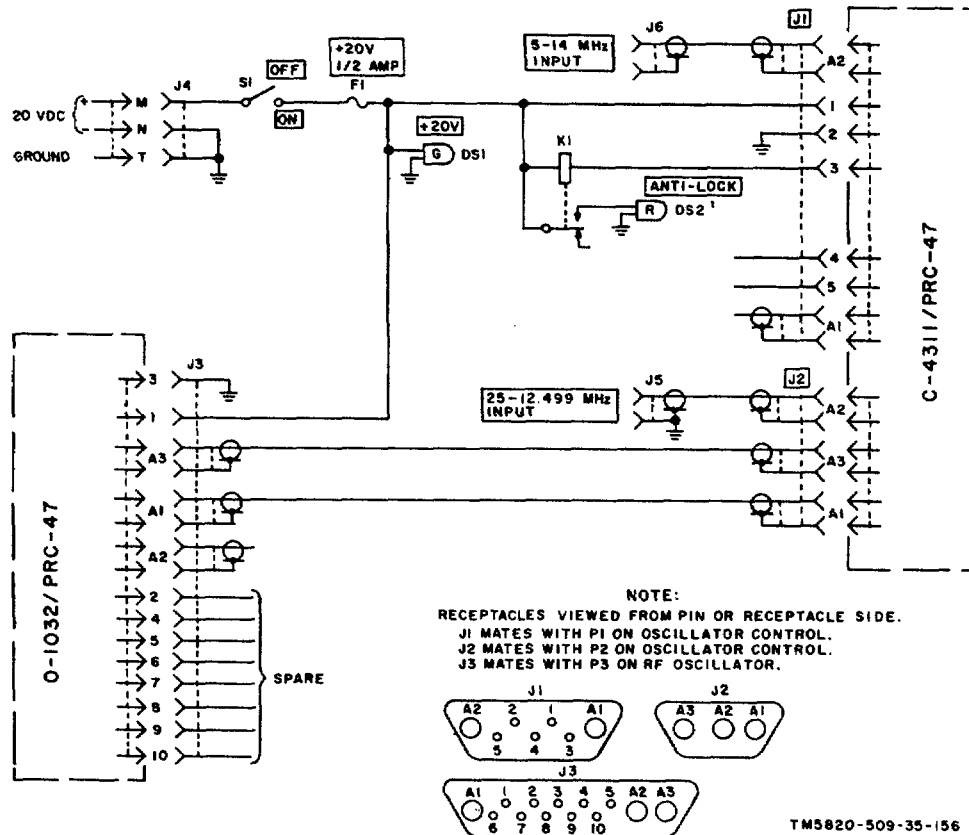

Figure 7-18. Test Fixture for Power Supply PP-3518/PRC-47, Schematic Diagram.



TM5820-509-35-155

Figure 7-19. Test Fixture for Radio Frequency Oscillator O-1032/PRC-47, Schematic Diagram.



TM5820-509-35-156

Figure 7-20. Test Fixture for Oscillator Control C-4311/PRC-47, Schematic Diagram.

**APPENDIX A
REFERENCES**

DA Pam 310-4	Index of Technical Manuals, Technical Bulletins, Supply Manuals (Types 7, 8, and 9), Supply Bulletins, and Lubrication Orders.
DA Pam 310-7	US Index Army Equipment of Modification Work Orders.
TM 11-5017	Output Meters TS-585A/U; 585B/U; 585C/U; and 585D/U.
TM 11-5129	Oscilloscopes AN/USM-50A; B; and C.
TM 11-5820-509-12	Operator and Organization Maintenance Manual: Radio Set AN/PRC-47.
TM 11-6625-200-15	Operator's, Organizational, DS, GS, and Depot Maintenance Manual: Multimeters ME-26A/U; 26B/U; 26C/U; and 26D/U.
TM 11-6625-320-12	Operator and Organizational Maintenance Manual: Voltmeter, Meter ME-30A/U and Voltmeters, Electronic ME-30B/U; 30C/U; and 30E /U.
TM 11 -6625-326- 12	Operator and Organizational Maintenance Manual including Repair Parts and Special Tool Lists: Analyzer, Spectrum AN/UPM-110.
TM 11-6625-935-12	Organizational Maintenance Manual: Audio Oscillators TS-312/FSM1, TS-312A/FSM-1, and TS-382/U, and Signal Generator TS-312B/ FSM-1.

**APPENDIX B
DIRECT SUPPORT, GENERAL SUPPORT, AND
DEPOT MAINTENANCE REPAIR PARTS
AND SPECIAL TOOLS LIST**

Section I. INTRODUCTION

B-1. Scope

This appendix lists repair parts and special tools required for the performance of direct support, general support, and depot maintenance of Radio Set AN/PRC-47.

B-2. General

This Repair Parts and Special Tools List is divided into the following sections.:

a. Repair Parts-Section II. A list of repair parts authorized for the performance of maintenance of maintenance at the direct support, general support, and depot level.

b. Special Tools, Test, and Support Equipment-Section III. A list of special tools, test and support equipment authorized for the performance of maintenance at the direct support, general support, and depot level.

c. Index - Federal Stock Number and Reference Number Cross Reference to Figure and Item Number - Section IV. A list of Federal stock numbers in ascending numerical sequence, followed by a list of reference numbers in ascending alphanumeric sequence, cross referenced to the illustration figure number and reference designation.

d. Index - Reference Designation Cross-Reference to Page Number - Section V. A list of reference designations cross-referenced to page numbers.

B-3. Explanation of Columns

The following provides an explanation of columns in the tabular lists

a. Source, Main tenance and Recoverability Codes (SMR), Column 1.

(1) Source code indicates the selection status and source for the listed item. Source codes are:

Code	Explanation
P	Repair parts which are stocked in or supplied from the GSA/DSA, or Army supply system and authorized for use at indicated maintenance categories.

Code	Explanation
P2	Repair parts which are procured and stocked for insurance purposes because the combat or military essentiality of the end item dictates that a minimum quantity be available in the supply system.
P9	Assigned to items which are NSA design controlled: unique repair parts, special tools, test, measuring and diagnostic equipment' which are stocked and supplied by the Army COMSEC logistic system, and which are not subject to the provisions of AR 380-41.
P10	Assigned to items which are NSA design controlled special sods, test, measuring and diagnostic equipment for COMSEC support, which are accountable under the provisions of AR 380-41, and which are stocked and supplied by the Army COMSEC logistic system.
M	Repair parts which are not procured or stocked, but are to be manufactured at indicated maintenance levels.
A	Assemblies which are not procured or stocked as such but are made up of two or more unite. Such component units carry individual stock numbers and descriptions, are procured and stocked separately, and can be assembled to form the required assembly at indicated maintenance categories.
X	Parts and assemblies which are not procured or stocked and the mortality of which normally is below that of the applicable end item or component. The failure of such part or assembly should result in retirement of the end item from the supply system.
X1	Repair parts which are not procured or stocked. The requirement for such items will be filled by use of the next higher assembly or component.
X2	Repair parts which are not stocked. The indicated maintenance category requiring such repair parts will attempt to obtain same through cannibalization. Where such repair parts are not obtainable through cannibalization, requirements will be requisitioned, with accompanying justification, through normal supply channels.
G	Major assemblies that are procured with PEMA funds for initial issue only as exchange assemblies at DSU and GSU level. These assemblies will not be stocked above DS and GS level or returned to depot supply level.

(2) Maintenance code indicates the lowest category of maintenance authorized to install the listed item. The maintenance level codes are:

Code	Explanation
C	Operator/crew
O	Organizational maintenance
F	Direct support maintenance
H	General support
D	maintenance Depot maintenance

(3) Recoverability code indicates whether unserviceable items should be returned for recovery or salvage. Items not coded are expendable. Recoverability codes are:

Code	Explanation
R	Repair parts and assemblies are economically repairable at DSU and GSU activities and are normally furnished by supply on an exchange basis.
S	Repair parts and assemblies which are economically repairable at DSU and GSU activities and which normally are furnished by supply on an exchange basis. When items are determined by GSU to be uneconomically repairable, they will be evacuated to a depot for evaluation and analysis before final disposition.
T	High dollar value recoverable repair parts which are subject to special handling and are issued on an exchange basis. Such repair parts normally are repaired or overhauled at depot maintenance activities.
U	Repair parts specifically selected for salvage by reclamation unite because d precious metal content, critical materials, or high dollar value reusable casings or castings.

b. *Federal Stock Number, Column 2.* Indicates the Federal stock number assigned to the item and will be used for requisitioning purposes.

c. *Description, Column 3.* Indicates the Federal item name and any additional description of the item required. A part number or other reference number is followed by the applicable five-digit Federal supply code for manufacturers in parentheses.

d. *Unit of Measure (U/M), Column 4.* A two character alphabetic abbreviation indicating the amount or quantity of the item upon which the allowances are based, e.g., ft. ea. pr, etc.

e. *Quantity Incorporated in Unit, Column 6.* Indicates the quantity of the item used in the assembly group. A "V" appearing in this column in lieu of a quantity indicates that a definite quantity cannot be indicated {e.g., shims, spacers, etc.. Subsequent appearances of the same item in the same assembly are indicated by the letters "REF."

f. *30-Day DS/GS Maintenance, 1 Year Per Equipment (Contingency), and Depot Maintenance, Columns 6, 7, 8, and 9.* Items authorized for requisition as required are identified by an asterisk in the allowance column. Subsequent appearances of the same item will have the letters "REF" in the applicable allowance columns.

g. *Illustrations, Column 10.* This column is divided as follows:

(1) *Figure number, column 10a.* Indicates the figure number of the illustration in which the item is shown.

(2) *Item number or reference designation, column 10b.* Indicates the reference designation used to identify the item in the illustration

B-4. Special Information

Not applicable.

B-5. How to Locate Repair Parts

a. When Federal stock number or reference number is unknown:

(1) *First.* Find the illustration covering the unit to which the repair part belongs.

(2) *Second.* Identify the repair part on the illustration and note the illustration figure number and reference designation of the repair part.

(3) *Third.* Using the reference designation cross-reference to page number index (sec. V) find the reference designation and note the page number listed. Locate the item in the repair parts list (sec. II).

b. When Federal stock number of reference number is known:

(1) *First.* Using the Federal stock number and reference number index (sec IV) find the pertinent Federal stock number or reference number and note the figure number and reference designation. This index is in ascending FSN sequence, followed by a list of reference numbers in ascending alphanumeric sequence, cross referenced to the illustration figure number and reference designation.

(2) *Second.* Using the reference designation cross-reference to page number index (sec V) find the reference designation and note the page number listed. Locate the item in the repair parts list (sec. II).

B-6. Federal Supply Code for Manufacturer (FSCM)

The FSCM is a 5-digit numeric code listed in SB 708-42 which is used to identify the manufacturer, distributor, or Government agency, etc.

(Next printed page is B-4.)

****REPAIR PARTS FOR DIRECT SUPPORT, GENERAL SUPPORT, AND DEPOT MAINTENANCE****																
(1) SMR CODE	(2) FEDERAL STOCK NUMBER	(3) DESCRIPTION Reference Number & Mfr. Code Usable on Code		(4) UNIT OF MEAS	(5) 30 DAY DS MAINTENANCE QTY INC IN UNIT	(6) 30 DAY GS MAINTENANCE ALLOWANCE			(7) 1 YR ALW ALLOWANCE			(8) DEPOT MAINT PER 100 EQUIP CNTGCTY	(9) ALW PER 100 EQUIP	(10) ILLUSTRATION		
						(a) 1-20	(b) 21-50	(c) 51-100	(a) 1-20	(b) 21-50	(c) 51-100			(a) FIG NO.	(b) ITEM NO.	
A--F-S	5820-861-3539	RADIO SET: ANPRC47; (80058)		EA	1											
	5820-062-6748	CASE, RADIO SET: CY3700PRC47; (80058)		EA	1											A1
P--D	5820-007-9544	CASE, TRANSIT: 021-0187-00; (98376)		EA	1						*	*				A1NP2
M-D		PLATE, IDENTIFICATION 767-0502-00; (13499)		EA	1											A1NP2
P-F-S	6135-087-2301	ADAPTER, BATTERY TERMINAL MX4430PRC47; (80058)		EA	1	*	*	*	*	*	*	*	*			A2
Y-D		BRACKET, COVER-PRESSED: 549-6252-003; (13499)		EA	1											A2MP1
P-D	5935-08-6228	CONNECTOR, RECEPTACLE, ELECTRICAL: 549-6245-002; (13499)		EA	2						*	*				A2J1
P-D	5310-349-847	NUT, PLAIN, HEXAGON: P334-0284-000; (77250)		EA	3						*	*				A2J1H1
P-D	5310-158-5240	WASHER, FLAT: 549-6244-002; (13499)		EA	2						*	*				A2JH2
P-D	5935-088-6228	CONNECTOR, RECEPTACLE. ELECTRICAL: 549-6245-002; (13499)		EA	REF						REF	REF				A2J2
P-D		NUT, PLAIN, HEXAGON: P334-0284-000; (77250)		EA	REF						REF	REF				A2J2H1
P-D		NUT, PLAIN, HEXAGON: P334-0284-000; (77250)		EA	REF						REF	REF				A2J2H2
P-D		WASHER, FLAT: 549-6244-002; (13499)		EA	REF						REF	REF				A2J2H3
M-D		COVER, BATTERY BOX: 549-6250-003; (13499)		EA	1											A2MP2
M-D	5935-951-3054	COVER, ELECTRICAL CONNECTOR: 10-243964-143; (77820)		EA	1											A2MP3
M-D		PIN, LOCATING: 549-6242-002; (13499)		EA	1											A2MP4
M-D		PLATE, IDENTIFICATION: 737-4765-000; (13499)		EA	1											A2MP5
P-D		STRIKE, CATCH: 549-6247-002; (13499)		EA	2						*	*				A2A1
X1-D		CATCH, LUGGAGE: SCB83314-2A; (98003)		EA	1						REF	REF				A2A1MP1
X1-D		SCREW, MACHINE: 549-6246-02; (13499)		EA	REF											A2A1MP1H1
P-D		STRIKE, CATCH: 549-6247-002; (13499)		EA	REF						REF	REF				A2A2
X1-D		CATCH, LUGGAGE: SCB83314-2A; (98003)		EA	REF						REF	REF				A2A2MP1
X1-D		SCREW, MACHINE: 549-6246-002; (13499)		EA	REF											A2A2MP1H1
P--F	5820-970-6766	ADAPTER, CABLE TO CONNECTOR: U239PRC47; (80058)		EA	1	*	*	*	*	*	*	*	*			A3
X1-D		BODY, ADAPTER: 549-6493-003; (13499)		EA	1											A3NP1

****REPAIR PARTS FOR DIRECT SUPPORT, GENERAL SUPPORT, AND DEPOT MAINTENANCE****															
(1) SMR CODE	(2) FEDERAL STOCK NUMBER	(3) DESCRIPTION Reference Number & Mfr. Code Usable on Code		(4) UNIT OF MEAS	(5) 30 DAY DS MAINTENANCE QTY INC IN UNIT	(6) 30 DAY GS MAINTENANCE ALLOWANCE			(7) 1 YR ALW ALLOWANCE			(8) DEPOT MAINT PER 100 EQUIP CNTGCTY	(9) ALW PER 100 EQUIP	(10) ILLUSTRATION	
						(a) 1-20	(b) 21-50	(c) 51-100	(a) 1-20	(b) 21-50	(c) 51-100			(a) FIG NO.	(b) ITEM NO.
X1-D		CONNECTOR, PLUG, ELECTRICAL: 164-28., (02660)		EA	1										A3P1
X1-D		NUT, PLAIN, HEXAGON: 549-6489-002, (13499)		EA	1										A3P1H1
X1-D		COVER, ADAPTER: 549-6490-002, (13499)		EA	1										A34P2
X1-D		SCREW, MACHINE: P343-0285-000, (77250)		EA	4										A3MP2HI
X1-D		SCREW, MACHINE: P343-0285-000, (77250)		EA	REF										A3MP2H2
X1-D		SCREW, MACHINE: P343-0285-000, (77250)		EA	REF										A3P2H3
X1-D		SCREW, MACHINE: P343-0285-000,(77250)		EA	REF										A3MP1H4
X1-D		WASHER, LOCK, SPRING MS35338-135, (96906)		EA	1										A3MP2H5
X1-D		WASHER, LOCK, SPRING MS35338-135, (96906)		EA	REF										A3MP2H6
X1-D		WASHER, LOCK, SPRING MS35338-135, (96906)		EA	REF										A3MP2H7
X1-D		WASHER, LOCK, SPRING MS35338-135, (96906)		EA	REF										A3MP2H8
X1-D		GASKET-ADAPTER 549-6491-002, (13499)		EA	1										A3MP3
X1-D		PLATE, IDENTIFICATION 757-4766-000, (13499)		EA	1										A3MP4
X1-D		POST, BINDING 7841, (72825)		EA	4										A3E1
X1-D		SCREW, MACHINE: LP51957-28M, (03038)		EA	1										A3E1H1
X1-D		WASHER, FLAT 310-6360-000, (79807)		EA	1										A3E1H2
X1-D		WASHER, LOCK- MS35338-136, (96906)		EA	1										A3E1H3
X1-D		WASHER, NONMETALLIC 302-0020-000; (74921)		EA	1										A3E1H1
X1-D		WASHER, NONMETALLIC 302-7000-000, (74921)		EA	1										A3E1H5
X1--D		POST, BINDING. 7841; (72825)		EA	REF										A3E2
X1-D		SCREW, MACHINE LP51957-28M; (03038)		EA	1										A3E2H1
X1-D		WASHER, FLAT. 310-6360-000; (79807)		EA	1										A3E2H2
X1-D		WASHER, LOCK, SPRING M635338-136; (96906)		EA	1										A3E2H3
X1-D		WASHER, NONMETALLIC: 302-0020-000; (74921)		EA	1										A3E2H4
X1-D		WASHER, NONMETALLIC : 302-7000-000; (74921)		EA	1										A3E2H5

****REPAIR PARTS FOR DIRECT SUPPORT, GENERAL SUPPORT, AND DEPOT MAINTENANCE****															
(1) SMR CODE	(2) FEDERAL STOCK NUMBER	(3) DESCRIPTION Reference Number & Mfr. Code Usable on Code		(4) UNIT OF MEAS	(5) 30 DAY DS MAINTENANCE QTY INC IN UNIT	(6) 30 DAY GS MAINTENANCE ALLOWANCE			(7) 1 YR ALW ALLOWANCE			(8) DEPOT MAINT PER 100 EQUIP CNTGCTY	(9) ALW PER 100 EQUIP	(10) ILLUSTRATION	
						(a) 1-20	(b) 21-50	(c) 51-100	(a) 1-20	(b) 21-50	(c) 51-100			(a) FIG NO.	(b) ITEM NO.
X1-D		POST, BINDING 7841, (72825)		EA	REF										A3E3
X1-D		SCREW, MACHINE LP51957-28M; (03038)		EA	1										A3S3H1
X1-D		WASHER, FLAT 310-6360-000; (79807)		EA	1										A3E3H2
X1-D		WASHER, LOCK, SPRING MS35338-136; (96906)		EA	1										A3E3H3
X1-D		WASHER, NONMETALLIC: 302-0020-000, (74921)		EA	1										A3E3H4
X1-D		WASHER, NONMETALLIC. 302-7000-000; (74921)		EA	1										A3E3H5
X1-D		POST, BINDING. 7841, (72825)		EA	REF										A3E4
X1-D		SCREW, MACHINE: LP51957-28M, (03038)		EA	1										A3E4H1
X1-D		WASHER, FLAT. 310-6360-000, (79807)		EA	1										A3E4H2
X1-D		WASHER, LOCK, SPRING MS35338-136; (96906)		EA	1										A3E4H3
X1-D		WASHER, NGNMETALLIC. 302-0020-000; (74921)		EA	1										A3E4H4
X1-D		WASHER, NOIMETALLIC: 302-7000-000; (74921)		EA	1										A3E4H5
Y1-D		TERMINAL, LUG. 2522-06-00-20, (78189)		EA	4										A3E5
X1-D		TERMINAL, LUG. 2522-06-00-20, (78189)		EA	REF										A3E6
X1-D		TERMINAL, LUG: 2522-06-00-20, (78189)		EA	REF										A3E7
X1-D		TERMINAL, LUG 2522-06-00-20, (78189)		EA	REF										A3E8
P-D	5935-432-6476	ADAPTER, CONNECTOR 756-2809-001, (1349 9)		EA	1							*	*		CP1
P-F-T	5985-087-2326	ANTENN- AS1320PRC47, (80058)		EA	1	*	*	*	*	*	*	*	*		A4
P-F-T		ANTENNA SUBASSEMBLY, WHIP. 548-9095-002; (13499)		EA	1	*	*	*	*	*	*	*	*		A4A1
A-F-S		ANTENNA 147, (23675)		EA	1										A4A1E1
P-D	5895-984-1066	SECTION, BASE CF76991, (23675)		EA	1							*	*		A4AE1MP1
P-D	5895-98h-1067	SECTION, LOWER CF75961, (23675)		EA	3							*	*		A4A1E1MP2
P-D	5895-984-1067	SECTION, LOWER CF75961, (23675)		EA	REF							REF	REF		A4A1E1MP3
P-D	5895-984-1067	SECTION, LOWER CF75961, (23675)		EA	REF							REF	REF		A4A1E1MP4
P-D	5895-060-4825	SECTION, TIP CF75991, (23675)		EA	1							*	*		A4A1E1MP5

****REPAIR PARTS FOR DIRECT SUPPORT, GENERAL SUPPORT, AND DEPOT MAINTENANCE****															
(1) SMR CODE	(2) FEDERAL STOCK NUMBER	(3) DESCRIPTION Reference Number & Mfr. Code Usable on Code		(4) UNIT OF MEAS	(5) 30 DAY DS MAINTENANCE QTY INC IN UNIT	(6) 30 DAY GS MAINTENANCE ALLOWANCE			(7) 1 YR ALW ALLOWANCE			(8) DEPOT MAINT PER 100 EQUIP CNTGCTY	(9) ALW PER 100 EQUIP	(10) ILLUSTRATION	
						(a) 1-20	(b) 21-50	(c) 51-100	(a) 1-20	(b) 21-50	(c) 51-100			(a) FIG NO.	(b) ITEM NO.
P-D	5895-984-1068	SECTION, TRANSITION: CF75971, (23675)		EA	1'							*	*	A4A1E1MP6	
P-D	5895-984-1069	SECTION, UPPER: CF75981, (23675)		EA	3							*	*	A4A1E1MP7	
P-D	5895-984-1069	SECTION, UPPER: CF75981, (23675)		EA	REF							REF	REF	A4A1E1MP8	
P-D	5895-984-1069	SECTION, UPPER: CF75981, (23675)		EA	REF	REF	REF							A4A1E1MP9	
P-F	5975-987-8830	BOOT, ANTENNA: 548-9097-003, (13499)		EA	1	*	*	*	*	*	*	*	*	ALAIMP1	
M-D		CASE, ANTENNA: 548-911-0004, (13499)		EA	1									A4A2	
P-F-S	5985-087-2305	ANTENNA: AS-1321PRC7., (80058)		EA	1	*	*	*	*	*	*	*	*	A5	
M-D		BAND, MARKER, CABLE: 797-4357-001; (13499)		EA	2									A5MP1	
M-D		BAND, MARKER, CABLE: 797-4357-001, (13499)		EA	REF									A5MP2	
M-D		BAND, MARKER, CABLE: 797-4358-01, (13499)		EA	1									A5MP3	
P-D		CLIP, ELECTRICAL: 30, (76545)		EA	2							*	*	ASE1	
P-D		CLIP, ELECTRICAL: 30, (76545)		EA	REF							REF	REF	ASE2	
P-D	6625-757-4144	CONTACT, ELECTRICAL: 554-7052-003, (13499)		EA	1							*	*	A5E3	
P-D	5910-117-5012	INSULATOR, STRAIN JAN121TYPENPEN2W5601, (81350)		EA	2							*	*	A5E4	
P-D	5910-117-5012	INSULATOR, STRAIN JAN121TYPENPEN2W5601, (81350)		EA	REF							REF	REF	A5E5	
P-D	5355-965-4878	KNOB 554-7409-002, (13499)		EA	1							*	*	A5MP4	
M-D	5315-823-8746	PIN, SPRING- MS16562-206, (96906)		EA	1									A5MP5	
M-D		SHAFT ASSEMBLY 554-7050-002, (13499)		EA	1									ASAI	
P-D	5820-798-9615	CAP, ELECTRICAL 554-7047-002, (13499)		EA	1							*	*	A5A1E1	
N-D	5315-823-8744	PIN, SPRING. MS16562-203, (96906)		EA	1									A5A1MP1	
M-D		SHAFT, STRAIGHT 554-7048-002, (13499)		EA	1									A5A1MP2	
P-D		SHELL, ELECTRICAL CONNECTOR- 548-9098-003, (13499)		EA	1							*	*	A5E2	
P-D	5305-719-5064	SCREW, MACHINE MS51959-30, (96906)		EA	3							*	*	A5E2H1	
P-D	5305-719-5064	SCREW, MACHINE MS51959-30, (96906)		EA	REF							REF	REF	A5E2H2	
P-D	5305-719-5064	SCREW, MACHINE MS51959-30, (96906)		EA	REF							REF	REF	A5F2H3	

SECTION II

TM 11-5820-509-35

****REPAIR PARTS FOR DIRECT SUPPORT, GENERAL SUPPORT, AND DEPOT MAINTENANCE****															
(1) SMR CODE	(2) FEDERAL STOCK NUMBER	(3) DESCRIPTION Reference Number & Mfr. Code Usable on Code		(4) UNIT OF MEAS	(5) 30 DAY DS MAINTENANCE QTY INC IN UNIT	(6) 30 DAY GS MAINTENANCE ALLOWANCE			(7) 1 YR ALW ALLOWANCE			(8) DEPOT MAINT PER 100 EQUIP CNTGCTY	(9) ALW PER 100 EQUIP	(10) ILLUSTRATION	
						(a) 1-20	(b) 21-50	(c) 51-100	(a) 1-20	(b) 21-50	(c) 51-100			(a) FIG NO.	(b) ITEM NO.
M-D		SHIM 554-7051-002, (13499)		EA	1										A5H1
P-D	5940-501-5832	TERMINAL LUG. 35107, (00779)		EA	1							*	*		A5E3
P-D	5305-059-8247	SCREW, MACHINE P343-0327-000, (77250)		EA	1							*	*		A5E3H1
P-D		WASHER, SPRING TENSION: 310-0078-000, (79807)		EA	1							*	*		A5E3H2
P-D		WIRE, ELECTRICAL 955-0421UTXhi9W, (77872)		FT	47							*	*		A5W1
P-F-S	5820-981-7539	FRAME, ACCESSORIES 549-6277-000, (13499)		EA	1	*	*	*	*	*	*	*	*		A6
M-D		BILLET, SHOULDER STRAP: 021-0192-000, (24036)		EA	4										A6MP1
Y-D		BILLET, SHOULDER STRAP 021-0192-000; (24036)		EA	REF										A6MP2
M-D		BILLET, SHOULDER STRAP- 021-0192-000, (24036)		EA	REF										A6MP3
M-D		BILLET, SHOULDER STRAP. 021-0192-000, (24036)		EA	REF										A6MP4
P-D	5340-947-6204	CLAMP ASSEMBLY 519-6281-002, (13499)		EA	2							10	4		A6A1
P-D		CLAMP, LOOP. 549-62782002, (13499)		EA	1							*	*		A6AIMP1
P-D		THUMBSCREW, LONG 553-9810-003, (13499)		EA	1							*	*		A6AIA1
P-D	5305-054-5648	SCREW, MACHINE: MS51957-14; (96906)		EA	1							*	*		A6A1A1H1
P-D		KINOB- 553-9806-002, (13499)		EA	1										A6A1A1MP1
M-D		PIN, SHOULDER, HEADLESS, LONG 553-9808-002, (13499)		EA	1										A6A1A1MP2
M-D	5315-754-1621	PIN, SPRING MS171503, (96906)		EA	1										A6A1A1MP3
P-D	5340-947-6200	CLAMP, ASSEMBLY 549-6281-002, (13499)		EA	REF							REF	REF		A6A2
P-D		CLAMP, LOOP 549-6278-002, (13499)		EA	1							REF	REF		A6A2MP1
P-D		THUMBSCREW, LONG 553-9810-003, (13499)		EA	REF							REF	REF		A6A2A1
P-D	5305-054-5648	SCREW, MACHINE MS51957-14, (96906)		EA	REF							REF	REF		A6A2AIH1
M-D		KNOB. 553-9806-002, (13499)		EA	REF										A6A2A1MP1
M-D		PIN, SHOULDER 553-9808-002, (13499)		EA	REF										A6A2A1MP2
M-D	5315-754-1621	PIN, SPRING MS171503, (96906)		EA	REF										A6A2A1MP3

****REPAIR PARTS FOR DIRECT SUPPORT, GENERAL SUPPORT, AND DEPOT MAINTENANCE****															
(1) SMR CODE	(2) FEDERAL STOCK NUMBER	(3) DESCRIPTION Reference Number & Mfr. Code Usable on Code		(4) UNIT OF MEAS	(5) 30 DAY DS MAINTENANCE QTY INC IN UNIT	(6) 30 DAY GS MAINTENANCE ALLOWANCE			(7) 1 YR ALW ALLOWANCE			(8) DEPOT MAINT PER 100 EQUIP CNTGCTY	(9) ALW PER 100 EQUIP	(10) ILLUSTRATION	
						(a) 1-20	(b) 21-50	(c) 51-100	(a) 1-20	(b) 21-50	(c) 51-100			(a) FIG NO.	(b) ITEM NO.
P-D	5340-758-5660	CLAMP, LOOP 549-6280-002; (13499)		EA	2							*	*	A6MP5	
P-D	5305-059-3663	SCREW, MACHINE MS51958-67, (96906)		EA	1							*	*	A6MP5H1	
P-D	5340-758-5660	CLAMP, LOOP 549-6280-002, (13499)		EA	REF							REF	REP	A6MP6	
P-D	5305-059-3663	SCREW, MACHINE MS51958-67, (96906)		EA	1							REF	REF	A6MP6H1	
M-D	5820-758-0064	HOLDER, FRAME, NO. 1: 549-6279-002, (13499)		EA	1									A6MP7	
P-D	5305-770-2580	SCREW, MACHINE MS51959-16, (96906)		EA	2							*	*	A6MP7H1	
P-D	5305-770-2580	SCREW, MACHINE MS51959-16, (96906)		EA	REF							REF	REF	A6MP7H2	
P-D	5820-758-0063	PLATE ASSEMBLY, SUPPORT 549-6293-004, (13499)		EA	1							*	*	A6A3	
M-D		PLATE, SUPPORT: 549-6287-002, (13499)		EA	1									A6A3MP1	
M-D		PLATE, SUPPORT 549-6289-003, (13499)		EA	1									A6A3MP2	
M-D		SUPPORT, SHOULDER STRAP: 021-0189-000, (13499)		EA	1									A6A3MP3	
P-D		NUT, SELF-LOCKING, HEXAGON 68NN62, (72962)		EA	2							*	*	A6A31P3H1	
P-D		NUT, SELF-LOCKING, HEXAGON 68NM62, (72962)		EA	REF							REF	REF	A6A3MP3H2	
P-D		SCREW, MACHINE P325-0066-000, (77250)		EA	2							*	*	A6A3MP3H3	
P-D		SCREW, MACHINE P325-0066-000, (77250)		EA	REF							REF	RE	A6A3M3H4	
P-D		WASHER, FLAT- 310-0447-000, (79807)		EA	2							*	*	A6A3MP3H5	
P-D		WASHER, FLAT 310-0447-000, (79807)		EA	REF							REF	REF	A634MP3H6	
P-D		THUMBSCREW, SHORT: 553-9809-003, (13499)		EA	2							*	*	A6A3A1	
P-D	5310-857-5548	NUT, SELF-LOCKING, HEXAGON: MS21044D04, (96906)		EA	1							*	*	A6A3A1H1	
P-D	5305-763-7822	SCREW, MACHINE MS51959-14, (96906)		EA	1							*	*	A6A3AH1	
M-D		KNOB 553-9806-002, (13499)		EA	1									A6A3A1MP1	
M-D		PIN, SHOULDER, HEADLESS, SHORT: 553-9807-002, (L3499)		EA	1									A6A3A1MP2	
M-D	5315-754-1621	PIN, SPRING MS171503, (96906)		EA	1									A6A3A1MP3	
P-D		THUMBSCREW, SHORT 553-9809-003, (13499)		EA	REF									A6A3A2	

****REPAIR PARTS FOR DIRECT SUPPORT, GENERAL SUPPORT, AND DEPOT MAINTENANCE****															
(1) SMR CODE	(2) FEDERAL STOCK NUMBER	(3) DESCRIPTION Usable on Code Reference Number & Mfr. Code		(4) UNIT OF MEAS	(5) 30 DAY DS MAINTENANCE QTY INC IN UNIT	(6) 30 DAY GS MAINTENANCE ALLOWANCE			(7) 1 YR ALW ALLOWANCE			(8) DEPOT MAINT PER 100 EQUIP CNTGCTY	(9) ALW PER 100 EQUIP	(10) ILLUSTRATION	
						(a) 1-20	(b) 21-50	(c) 51-100	(a) 1-20	(b) 21-50	(c) 51-100			(a) FIG NO.	(b) ITEM NO.
P-D	5310-857-5548	NUT, SELF-LOCKING, HEXAGON: MS21044D04; (96906)		EA	1							REF	REF	A6A3A2H1	
P-D	5305-763-7822	SCREW, MACHINE MS51959-14; (96906)		EA	1							REF	REF	A6A3A2H1	
M-D		KNOB: 553-9806-002; (13499)		EA	1									A6A3A2MP1	
M-D		PIN, SHOULDER, HEADLESS, SHORT: 553-9807-002; (13499)		EA	1									A6A3A2MP2	
M-D		PIN, SPRING: MS171503; (96906)		EA	1									A6A3A2MP3	
M-D	5110-115-5049	RETAINER, BATTERY-RIVETED 549-6292-003; (13499)		EA	1									A6A4	
P-D	5340-290-0939	BUCKLE: 11NO1136STL; (76786)		EA	2							*	*	A6A4MP1	
P-D	5340-290-0939	BUCKLE: 11NO1136STL; (76786)		EA	REF							REF	REF	A6A4MP2	
M-D	5820-960-7832	STRAP, BACK: WAGC6347; (79215)		EA	2									A6MP8	
M-D	5820-960-7832	STRAP, BACK: WAGC6347; (79215)		EA	REF									A6MP9	
M-D	5340-734-5982	STRAP, WEBBING-SECURING: 549-6282-002; (13499)		EA	1									A6MP10	
P-F-T		HANDSET, H-33G1P, 977-0049-010		EA	1	*	*	*	*	*	*	*	*		
P-D	5965-985-3589	HEADSET, ELECTRICAL: H233PRC47; (80058)		EA	1									HT1	
P-F-T	5820-062-4758	LEG, ELECTRICAL EQUIPMENT MT2786PRC47; (80058)		EA	1	*	*	*	*	*	*	*	*	A7	
M-D		CASE, LEGS: 549-6495-004; (13499)		EA	1									A7MP1	
M-D	5820-795-9368	LEG, ELECTRICAL EQUIPMENT 549-6494-003; (13499)		EA	2									A7A1	
M-D		BUSHING, SLEEVE: 549-6482-002; (13499)		EA	2									A7A1MP1	
M-D		BUSHING, SLEEVE: 549-6482-002; (13499)		EA	REF									A7A1MP2	
P-D	5340-795-9364	CLAMP, FRICTION-FEMALE: 549-6486-002; (13499)		EA	2							*	*	A7A1MP3	
P-D	5340-795-9364	CLAMP, FRICTION- FEMALE: 549-6486-002; (13499)		EA	REF							REF	REF	A7A1WP4	
M-D		COUNTERPOISE SUBASSEMBLY. 549-6477-002; (13499)		EA	1									A7A1E1	
P-D	6145-191-8397	BRAID, WIRE: 36062; (75818)		FT	64							*	*	A7A1E1W1	
P-D		PLUG, TIP: 108; (83330)		EA	1							*	*	A7A1E1P1	
M-D	5820-795-9369	HOUSING, LEG-HINGE: 549-6487-002; (13499)		EA	2									A7A1MP5	
M-D	5820-795-9369	HOUSING, LEG-HINGE: 549-6487-002; (13499)		EA	REF									A7A1MP6	

SECTION II

TM 11-5820-509-35

****REPAIR PARTS FOR DIRECT SUPPORT, GENERAL SUPPORT, AND DEPOT MAINTENANCE****															
(1) SMR CODE	(2) FEDERAL STOCK NUMBER	(3) DESCRIPTION Reference Number & Mfr. Code Usable on Code		(4) UNIT OF MEAS	(5) 30 DAY DS MAINTENANCE QTY INC IN UNIT	(6) 30 DAY GS MAINTENANCE ALLOWANCE			(7) 1 YR ALW ALLOWANCE			(8) DEPOT MAINT PER 100 EQUIP CNTGCTY	(9) ALW PER 100 EQUIP	(10) ILLUSTRATION	
						(a) 1-20	(b) 21-50	(c) 51-100	(a) 1-20	(b) 21-50	(c) 51-100			(a) FIG NO.	(b) ITEM NO.
M-D		LEG, SECTION, ELECTRICAL EQUIPMENT: 549-6478-002, (13499)		EA	1										A7A1MP7
M-D		LEG, SECTION, ELECTRICAL EQUIPMENT: 549-6479-002, (13499)		EA	1										A7A1MP8
M-D	5820-795-9R71	PLATE, LEG MOUNTING: 549-6483-002, (13499)		EA	1										A7A1MP9
P-D	5820-795-9370	RETAINER, LEG: 549-6484-002; (13499)		EA	2										A7A1MP10
P-D	5310-934-9765	NUT, PLAIN, HEXAGON: NS35650-304, (96906)		EA	2										A7A1MP10H1
P-D	5310-934-9765	NUT, PLAIN, HEXAGON: MS35650-304, (96906)		EA	REF						REF	REF			A7A1MP10H2
P-D	5305-071-1325	SCREW, MACHINE: MS51960-68, (96906)		EA	2						*	*			A7A1MP10H3
P-D	5305-071-1325	SCREW, MACHINE: NS51960-68, (96906)		EA	REF						REF	REF			A7A1MP10H4
P-D	5310-933-8120	WASHER, LOCK, SPRING: MS35338-138, (96906)		EA	2						*	*			A7A1MP10H5
P-D	5310-933-8120	WASHER, LOCK, SPRING: MS35338-138; (96906)		EA	REF						REF	REF			A7A1MP10H6
P-D	5820-795-9370	RETAINER, LEG: 549-6484-002; (13499)		EA	REF						REF	REF			A7A1MP11
P-D	5310-934-9765	NUT, PLAIN, HEXAGON: MS35650-304; (96906)		EA	2						REF	REF			A7A1MP11H1
P-D	5310-938&9765	NUT, PLAIN, HEXAGON: MS35650-3o40, (96906)		EA	REF						REF	REF			A7A1MP11H2
P-D	5305-071-1325	SCREW, MACHINE: NS51960-68, (96906)		EA	2						REF	REF			A7A1MP11H3
P-D	5305-71-1325	SCREW, MACHINE: MS51960-68, (96906)		EA	REF						REF	REF			A7A1MP11H4
P-D	5310-933-8120	WASHER, LOCK, SPRING: Ns35338-138; (96906)		EA	2						REF	REF			A7A1MP11H5
P-D	5310-9338120	WASHER, LOCK, SPRING: NS35338-138, (96906)		EA	REF						REF	REF			A7A1MP11H6
P-D	5305-788-9883	STUD, WING: 549-6475-002, (13499)		EA	2						*	*			A7A1A
M-D		PIN, GROOVED, HEADLESS: MS35672-14, (96906)		EA	1										A7A1A1MP1
M-D		PIN, SHOULDERED, HEADLESS: 549-6476-002, (13499)		EA	1										A7A1A1MP2
M-D		WING, STUD: 549-6480-002, (13499)		EA	1										A7A1A1MP3
P-D	5305-788-9883	STUD, WING 549-667-0002; (13499)		EA	REF						REF	REF			A7A1A2
M-D		PIN, GROOVED, HEADLESS: MS35672-14, (96906)		EA	1										A7A1A2MP1
M-D		PIN, SHOULDERED, HEADLESS: 549-76-002, (13&99)		EA	1										A7A1A2MP2

****REPAIR PARTS FOR DIRECT SUPPORT, GENERAL SUPPORT, AND DEPOT MAINTENANCE****															
(1) SMR CODE	(2) FEDERAL STOCK NUMBER	(3) DESCRIPTION Reference Number & Mfr. Code Usable on Code		(4) UNIT OF MEAS	(5) 30 DAY DS MAINTENANCE QTY INC IN UNIT	(6) 30 DAY GS MAINTENANCE ALLOWANCE			(7) 1 YR ALW ALLOWANCE			(8) DEPOT MAINT PER 100 EQUIP CNTGCTY	(9) ALW PER 100 EQUIP	(10) ILLUSTRATION	
						(a) 1-20	(b) 21-50	(c) 51-100	(a) 1-20	(b) 21-50	(c) 51-100			(a) FIG NO.	(b) ITEM NO.
M-D		WING, STUD: 549-6480-002, (13499)		EA	1										A7A1A2MP3
P-D	5310-938-8387	WASHER: 542-1598-003, (13499)		EA	2							*	*		A7A1H1
P-D	5310-685-7469	WASHER: 542-1598-003; (13499)		EA	REF							REF	REF		A7A1H2
M-D		LEG, ELECTRICAL EQUIPMENT: 549-6494-003; (13499)		EA	REF										A7A2
M-D	3120-368-7946	BUSHING, SLEEVE: 549-6482-002; (13499)		EA	2										A7A2MP1
M-D	3120-768-7946	BUSHING, SLEEVE: 549-6482-002; (13499)		EA	REF										A7A2MP2
P-D	5340-795-9364	CLAMP, FRICTION-FEMALE: 549-6486-002; (13499)		EA	2							REF	REF		A7A2MP3
P-D	5340-795-9364	CLAMP, FRICTION-FEMALE: 5,9-6486-002; (13199)		EA	REF							REF	REF		A7A2MP4
M-D		COUNTERPOISE: 549-6477-002; (1399)		EA	1										A7A2E1
P-D	6145-191-8397	BRAID, WIRE: 36062; (75818)		FT	63							REF	REF		A7A2E1W1
P-D		PLUG, TIP: 108; (83330)		EA	REF							REF	REF		A7A2E1P1
M-D		HOUSING, LEG-HINGE: 549-6487-002, (13499)		EA	2										A7A2MP5
M-D		HOUSING, LEG-HINGE: 549-6487-002; (13499)		EA	REF										A7A2MP6
M-D	5820-T66-1827	LEG SECTION, ELECTRICAL EQUIPMENT: 549-6478-002; (13499)		EA	1										A7A2MP7
M-D	5820-766-1828	LEG SECTION, ELECTRICAL EQUIPMENT: 549-6479-002; (13499)		EA	1										A7A2MP8
M-D		PLATE, LEG MOUNTING: RETAINER LEG: 549-6484L-02; (13499)		EA	1							REF	REF		A7A2MP9
P-D	5820-795-9370			EA	2										A7A2MP10
P-D	5310-934-9765	NUT, PLAIN, HEXAGON: MS35650-304; (96906)		EA	2							REF	REF		A7A2MP10H1
P-D	5310-934-9765	NUT, PLAIN, HEXAGON: MS35650-304; (96906)		EA	REF							REF	REF		A7A2MP10H2
P-D	5305-071-1325	SCREW, MACHINE: MS51960-68; (96906)		EA	2							REF	REF		A7A2MP10H3
P-D	5305-071-1325	SCREW, MACHINE: MS51960-68; (96906)		EA	REF							REF	REF		A7A2MP10H4
P-D	5310-933-8120	WASHER, LOCK, SPRING: MS35338-138; (96906)		EA	2							REF	REF		A7A2MP10H5
P-D	5310-9338120	WASHER, LOCK, SPRING: MS35338-138; (96906)		EA	REF							REF	REF		A7A2MP10H6
P-D	5820-795-9370	RETAINER, LEG. 549-6484-002; (13499)		EA	REF							REF	REF		A7A2MP11
P-D	5310-934-9765	NUT, PLAIN, HEXAGON: MS35650-304, (96906)		EA	2							REF	REF		A7A2MP11H1

****REPAIR PARTS FOR DIRECT SUPPORT, GENERAL SUPPORT, AND DEPOT MAINTENANCE****															
(1) SMR CODE	(2) FEDERAL STOCK NUMBER	(3) DESCRIPTION Reference Number & Mfr. Code Usable on Code		(4) UNIT OF MEAS	(5) 30 DAY DS MAINTENANCE QTY INC IN UNIT	(6) 30 DAY GS MAINTENANCE ALLOWANCE			(7) 1 YR ALW ALLOWANCE			(8) DEPOT MAINT PER 100 EQUIP CNTGCTY	(9) ALW PER 100 EQUIP	(10) ILLUSTRATION	
						(a) 1-20	(b) 21-50	(c) 51-100	(a) 1-20	(b) 21-50	(c) 51-100			(a) FIG NO.	(b) ITEM NO.
P-D	5310-934-9765	NUT, PLAIN, HEXAGON: MS35650-304; (96906)		EA	REF							REF	REF		A7A2MP11H2
P-D	5305-071-1325	SCREW, MACHINE: MS51960-68; (96906)		EA	2							REF	REF		A7A2MP11H3
P-D	5305-071-1325	SCREW, MACHINE: MS51960-68; (96906)		EA	REF							REF	REF		A7A2MP11H4
P-D	5310-933-8120	WASHER, LOCK, SPRING: MS35338-138; (96906)		EA	2							REF	REF		A7A2MP11H5
P-D	5310-933-8120	WASHER, LOCK, SPRING: MS35338-138; (96906)		EA	REF							REF	REF		A7A2MP11H6
P-D		STUD, WING: 549-6475-002; (13499)		EA	2							REF	REF		A7A2A1
M-D		PIN, GROOVED, HEADLESS. MS35672-14; (96906)		EA	REF										A7A2A1MP1
M-D		PIN, SHOULDERED, HEADLESS: 549-676-002; (13499)		EA	1										A7A2A1MP2
M-D		WING, STUD 549-6480-002; (13499)		EA	REF										A7A2A1MP3
P-D		STUD, WING: 549-6475-002; (13499)		EA	REF							REF	REF		A7A2A2
M-D		PIN, GROOVED, HEADLESS: MS35672-14; (96906)		EA	1										A7A2A2MP1
M-D		PIN, SHOULDERED, HEADLESS: 549-676-002; (13499)		EA	1										A7A2A2MP2
M-D		WING, STUD 549-6480-002; (13499)		EA	REF										A7A2A2MP3
P-D		WASHER : 542-1598-003; (13499)		EA	2							REF	REF		A7A2H1
P-D		WASHER : 542-1598-003; (13499)		EA	REF							REF	REF		A7A2H2
M-D		PLATE, IDENTIFICATION: 757-4764-000; (13499)		EA	2										A7MP1
M-D		PLATE, IDEFTIFICATION: 757-4764-000; (13499)		EA	REF										A7MP2
M-D		PLATE, IDEFTIFICATION: 757-4764-000; (13499)		EA	1										MP4
P-F-S	5820-082-1599	RECEIVER-TRANSMITTER, RADIO: RT671PRC47; (80058)		EA	1	*	*	*	*	*	*	*	*	3-4	A8
P-H-S	5820-087-2314	CONTROL, OSCILIATOR: C4311PRC47; (80058)		EA	1						*	*	*	3-4	A8A7
P-H-T	5820-975-5417	AMPLIFIER, RADIO FREQUENCY. 549-5788-004; (13499)		EA	1					*	*	*	*	3-14	A8A7E4
X1-D		BOARD, PRINTED CIRCUIT: 549-5790-004; (13499)		EA	1									3-57	A8A7E4E1
X1-D		CAPACITOR, FIXED, CERAMIC: 6S8083; (56289)		EA	4									3-57	A8A7E4C57
X1-D		CAPACITOR, FIXED, CERAMIC: 6S8083; (56289)		EA	REF									3-57	A8A7E4C59
X1-D		CAPACITOR, FIXED, CERAMIC: 6S8083; (56289)		EA	REF									3-57	A8A7E4C60

****REPAIR PARTS FOR DIRECT SUPPORT, GENERAL SUPPORT, AND DEPOT MAINTENANCE****															
(1) SMR CODE	(2) FEDERAL STOCK NUMBER	(3) DESCRIPTION Reference Number & Mfr. Code Usable on Code		(4) UNIT OF MEAS	(5) 30 DAY DS MAINTENANCE QTY INC IN UNIT	(6) 30 DAY GS MAINTENANCE ALLOWANCE			(7) 1 YR ALW ALLOWANCE			(8) DEPOT MAINT PER 100 EQUIP CNTGCTY	(9) ALW PER 100 EQUIP	(10) ILLUSTRATION	
						(a) 1-20	(b) 21-50	(c) 51-100	(a) 1-20	(b) 21-50	(c) 51-100			(a) FIG NO.	(b) ITEM NO.
X1-D		CAPACITOR, FIXED, CERAMIC. 6S8083, (56289)		EA	REF									3-57	A8A6E4C63
X1-D		CAPACITOR, FIXED, ELECTROLYTIC. 150D104X0035A2, (56289)		EA	2									3-57	A8A7E4C58
X1-D		CAPACITOR, FIXED, ELECTROLYTIC: 150D104X0035A2; (56289)		EA	REF									3-57	A8A7E4C61
X1-D		CAPACITOR, FIXED, MICA: CM05CD100D03; (81349)		EA	1									3-57	A8A7E4C56
X1-D		CAPACITOR, FIXED, MICA CM05ED220J03; (81349)		EA	3									3-57	A8A7E4C66
X1-D		CAPACITOR, FIXED, MICA CM05ED220J03; (81349)		EA	REF									3-57	A8A7E4C68
X1-D		CAPACITOR, FIXED, MICA CM05ED220J03, (81349)		EA	REF									3-57	A8A7E4C70
X1-D		CAPACITOR, FIXED, MICA: CM05ED390J03, (81349)		EA	3									3-57	A8A7E4C65
X1-D		CAPACITOR, FIXED, MICA CM05ED390J03, (81349)		EA	REF									3-57	A8A7E4C67
X1-D		CAPACITOR, FIXED, MICA CM05ED390J03, (81349)		EA	REF									3-57	A8A7E4C69
X1-D		CAPACITOR, FIXED, MICA: DM15F471J300WV4CR, (72136)		EA	1									3-57	A8A7E4C62
X1-D		COIL, RADIO FREQUENCY LT10K020; (81349)		EA	3									3-57	A8A7E4L16
X1-D		COIL, RADIO FREQUENCY LT10K020; (81349)		EA	REF									3-57	A8A7E4L17
X1-D		COIL, RADIO FREQUENCY LT10K020; (81349)		EA	REF									3-57	A8A7E4L18
X1-D		RESISTOR, FIXED, COMPOSITION RCR07G121KS; (81349)		EA	2									3-57	A8ATE4R88
X1-D		RESISTOR, FIXED, COMPOSITION RCR07G121KS; (81349)		EA	REF									3-57	A8A7E4R93
X1-D		RESISTOR, FIXED, COMPOSITION RCR07G221KS, (81349)		EA	1									3-57	A8A7E4R97
X1-D		RESISTOR, FIXED, COMPOSITION RCR07G561KS, (81349)		EA	2									3-57	A8A7E4R92
X1-D		RESISTOR, FIXED, COMPOSITION: RCR07G561KS; (81349)		EA	REF									3A8	A8A7E4R102
X1-D		RESISTOR, FIXED, COMPOSITION: RCR07G392KS; (81349)		EA	2									3-57	A8A7E4R95
X1-D		RESISTOR, FIXED, COMPOSITION. RCR07G392KS; (81349)		EA	REF									3-57	A8A7E4R101
X1-D		RESISTOR, FIXED, COMPOSITION RCR07G472KS; (81349)		EA	2									3-57	A8A7E4R90
X1-D		RESISTOR, FIXED, COMPOSITION RCR07G472KS; (81349)		EA	REF									3-57	A8A7E4R99
X1-D		RESISTOR, FIXED, COMPOSITION RCR07G562KS, (81349)		EA	2									3-57	A8A7E4R91
X1-D		RESISTOR, FIXED, COMPOSITION RCR07G562KS; (81349)		EA	REF									3-51	A8A7E4R96

SECTION II

TM 11-5820-509-35

****REPAIR PARTS FOR DIRECT SUPPORT, GENERAL SUPPORT, AND DEPOT MAINTENANCE****															
(1) SMR CODE	(2) FEDERAL STOCK NUMBER	(3) DESCRIPTION Reference Number & Mfr. Code Usable on Code		(4) UNIT OF MEAS	(5) 30 DAY DS MAINTENANCE QTY INC IN UNIT	(6) 30 DAY GS MAINTENANCE ALLOWANCE			(7) 1 YR ALW ALLOWANCE			(8) DEPOT MAINT PER 100 EQUIP CNTGCTY	(9) ALW PER 100 EQUIP	(10) ILLUSTRATION	
						(a) 1-20	(b) 21-50	(c) 51-100	(a) 1-20	(b) 21-50	(c) 51-100			(a) FIG NO.	(b) ITEM NO.
X1-D		RESISTOR, FIXED, COMPOSITION RCR07G822KS, (81349)		EA	1									3-57	A8A7E4R100
X1-D		RESISTOR, FIXED, COMPOSITION RCR07G825KS, (81349)		EA	3									6-67	A8A7E4R89
X1-D		RESISTOR, FIXED, COMPOSITION: RCR07G825KS, (81349)		EA	REF									3-57	A8A7E4R94
X1-D		RESISTOR, FIXED, COMPOSITION RCR07G825KS, (81349)		EA	REF									3-57	A8A7E4R98
X1-D		TRANSISTOR 2N703, (07688)		EA	3									3-57	A8A7E4Q17
X1-D		TRANSISTOR 2N703; (07688)		EA	REF									3-57	A8A7E4Q18
X1-D		TRANSISTOR 2N703, (07688)		EA	REF									3-57	A8A7E4Q19
P-D		BEARING, BALL, ANNULAR: NM2032ZM3E; (43334)		EA	2						*	*			A8A7MP1
P-D		BEARING, BALL, ANNULAR:: NM2032ZM3E; (43334)		EA	REF						REF	REF			A8A7MP2
P-D	3120-865-8571	BEARING,SLEEVE, FLANGED, NYLON: 3L3F, (96881)		EA	1						*	*			A8A7MP3
P-D		BUTTON, CABLE: 541-5179-002; (13499)		EA	1						*	*			A8ATMP4
P-D	5910-583-1997	CAPACITOR, FIXED, CERAMIC 2465-009W5T0102P, (72982)		EA	4						*	*	3-61	ASA7C181	
P-D	5910-583-1997	CAPACITOR, FIXED, CERAMIC 2465-009W5T0102P, (72982)		EA	REF						REF	REF	3-61	A8A7C182	
P-D	5910-583-1997	CAPACITOR, FIXED, CERAMIC 2465-009W5T0102P, (72982)		EA	REP						REF	REF	3-61	A8A7C183	
P-D	5910-583-1997	CAPACITOR, FIXED, CERAMIC: 2465-009W5T0102P, (72982)		EA	REF						REF	REF	3-61	A8A6C184	
X1-D		CHASSIS, ELECTRICAL EQUIPMENT 549-5809-005, (13499)		EA	1										A8A7MP5
X1-D		CHASSIS, FILTER: 756-0318-004, (13499)		EA	1										A8A7MP6
P-D	5950-828-1343	COIL, RADIO FREQUENCY LT10K043; (81349)		EA	4						*	*	3-61	A8A7L34	
P-D	5950-828-1343	COIL, RADIO FREQUENCY LT10K043, (81349)		EA	REF						REF	REF	3-61	ASA7L35	
P-D	59-828-1343	COIL, RADIO FREQUENCY LT10K043; (81349)		EA	REF						REF	REF	3-61	A8A7L36	
P-D	59 828-1343	COIL, RADIO FREQUENCY LT10K043; (81349)		EA	REF						REF	REF	3-61	A8A7L37	
P-D		CONNECTOR, RECEPTACLE, ELECTRICAL. DAM3W3P, (71468)		EA	1						*	*			A8A7P2
P-D	5305-7702533	SCREW, MACHINE MS51959-13, (96906)		EA	1										A8A7P2H1
P-D	5305-763-7822	SCREW, MACHINE MS51959-14, (96906)		EA	1						REF	REF			A8A7P2H2
P-D	5310-058-3599	WASHER, LOCK: MS35335-51, (96906)		EA	1										A8A7P2H3

****REPAIR PARTS FOR DIRECT SUPPORT, GENERAL SUPPORT, AND DEPOT MAINTENANCE****															
(1) SMR CODE	(2) FEDERAL STOCK NUMBER	(3) DESCRIPTION Reference Number & Mfr. Code Usable on Code		(4) UNIT OF MEAS	(5) 30 DAY DS MAINTENANCE QTY INC IN UNIT	(6) 30 DAY GS MAINTENANCE ALLOWANCE			(7) 1 YR ALW ALLOWANCE			(8) DEPOT MAINT PER 100 EQUIP CNTGCTY	(9) ALW PER 100 EQUIP	(10) ILLUSTRATION	
						(a) 1-20	(b) 21-50	(c) 51-100	(a) 1-20	(b) 21-50	(c) 51-100			(a) FIG NO.	(b) ITEM NO.
X1-D		WASHER, LOCK, SPRING: MS35338-135; (96906)		EA	1							REF	REF		A8A7P2H4
P-D	5935-810-6598	CONNECTOR, RECEPTACLE, ELECTRICAL DAM7W2P, (71468)		EA	1							*	*	3-61	A8A7P1
P-D	5310-614-3500	NUT, SELF-LOCKING, HEXAGON: 68-1660-40; (72962)		EA	2							*	*		A8A7P1H1
P-D	5310-614-3500	NUT, SELF-LOCKING, HEXAGON: 68-1660-40; (72962)		EA	REF							REF	REF		A8A7P1H2
P-D	5305-763-7822	SCREW, MACHINE. MS51959-14, (96906)		EA	2							REF	REF		A8A7P1H3
P-D	5305-763-7822	SCREW, MACHINE MS51959-14, (96906)		EA	REF							REF	REF		A8A7P1H4
P-D	5935-885-6505	CONTACT, ELECTRICAL, COAXIAL INSERT: DM53740-5000; (71468)		EA	5							*	*		A8A7P1A1
P-D	5935-885-6505	CONTACT, ELECTRICAL, COAXIAL INSERT: DM53740-5000; (71468)		EA	REF							REF	REF		A8A7P1A2
P-D	5935-885-6505	CONTACT, ELECTRICAL, COAXIAL INSERT: DM53740-5000; (71468)		EA	REF							FEF	REF		A8A7P2A1
P-D	5935-885-6505	CONTACT, ELECTRICAL, COAXIAL INSERT: DM53740-5000; (71468)		EA	REF							REF	REF		A8A7P2A2
P-D	5935-885-6505	CONTACT, ELECTRICAL, COAXIAL INSERT: DM53740-5000; (71468)		EA	REF							REF	REF		A9A7P2A3
P-H-S		CONTROL, SUBASSEMBLY, OSCILLATOR: 549-5776-004, (13499)		EA	1				*	*	*	*	*	3-4	A8A7E7
P-D		CAPACITOR ASSEMBLY: 549-5777-004; (13499)		EA	1							*	*	3-60	A8A7E7A1
P-D	5310-6114-3500	NUT, SELF-LOCKING, HEXAGON: 68-1660-40; (72962)		EA	2							REF	REF		A8A7E7A1H2
P-D	5305-054-5653	SCREW, MACHINE: MS51957-19; (96906)		EA	2							*	*		A8A7E7A1H2
P-D	5310-530-3549	WASHER, NONMETALLIC, FLAT 8942; (76854)		EA	*							*	*		A8A7E7A1H4
X1-D		BOARD, PRINTED CIRCUIT 549-5764-003; (13499)		EA	1									3-60	A8A7E7A1E8
X1-D		CAPACITOR, FIXED, MICA: CM05ED300G03, (81349)		EA	20									3-60	A8A7E7A1C114
X1-D		CAPACITOR, FIXED, MICA: CM05ED300G03, (81349)		EA	REF									3-60	A8A7E7A1C116
X1-D		CAPACITOR, FIXED, MICA: CM05ED300G03, (81349)		EA	REF									3-60	A8A7E7A1C118
X1-D		CAPACITOR, FIXED, MICA: CM05ED300G03, (81349)		EA	REF									3-60	A8A7E7A1C120
X1-D		CAPACITOR, FIXED, MICA: CM05ED300G03, (81349)		EA	REF									3-60	A8A7E7A1C122
X1-D		CAPACITOR, FIXED, MICA: CM05ED300G03, (81349)		EA	REF									3-60	A8A7E7A1C124
X1-D		CAPACITOR, FIXED, MICA: CM05ED300G03, (81349)		EA	REF									3-60	A8A7E7A1C126
X1-D		CAPACITOR, FIXED, MICA: CM05ED300G03, (81349)		EA	REF									3-60	A8A7E7A1C128
*SELECT PER OPERATIONAL REQUIREMENT.															

****REPAIR PARTS FOR DIRECT SUPPORT, GENERAL SUPPORT, AND DEPOT MAINTENANCE****															
(1) SMR CODE	(2) FEDERAL STOCK NUMBER	(3) DESCRIPTION Reference Number & Mfr. Code Usable on Code		(4) UNIT OF MEAS	(5) 30 DAY DS MAINTENANCE QTY INC IN UNIT	(6) 30 DAY GS MAINTENANCE ALLOWANCE			(7) 1 YR ALW ALLOWANCE			(8) DEPOT MAINT PER 100 EQUIP CNTGCTY	(9) ALW PER 100 EQUIP	(10) ILLUSTRATION	
						(a) 1-20	(b) 21-50	(c) 51-100	(a) 1-20	(b) 21-50	(c) 51-100			(a) FIG NO.	(b) ITEM NO.
X1-D		CAPACITOR, FIXED, MICA: CM05ED300G03, (81349)		EA	REF									3-60	A8A7E7 A1C130 *
X1-D		CAPACITOR, FIXED, MICA: CM05ED300G03, (81349)		EA	REF									3-60	A8A7E7 A1C132 *
X1-D		CAPACITOR, FIXED, MICA: CM05ED300G03, (81349)		EA	REF									3-60	A8A7E7 A1C134 *
X1-D		CAPACITOR, FIXED, MICA: CM05ED300G03, (81349)		EA	REF									3-60	A8A7E7 A1C136 *
X1-D		CAPACITOR, FIXED, MICA: CM05ED300G03, (81349)		EA	REF									3-60	A8A7E7 A1C138 *
X1-D		CAPACITOR, FIXED, MICA:- CM05ED300G03, (81349)		EA	REF									3-60	A8A7E7 A1C140 *
X1-D		CAPACITOR, FIXED, MICA: CM05ED300C03, (81349)		EA	REF									3-60	A8A7E7 A1C142 *
X1-D		CAPACITOR, FIXED, MICA: CM05ED300G03, (81349)		EA	REF									3-60	A8A7E7 * A1C144
X1-D		CAPACITOR, FIXED, MICA: CM05ED300G03, (81349)		EA	REF									3-60	A8A7E7 * A1C146
X1-D		CAPACITOR, FIXED, MICA: CM05ED300G03, (81349)		EA	REF									3-60	A8A7E7 A1C148 *
X1-D		CAPACITOR, FIXED, MICA: CM05ED300G03, (81349)		EA	REF									360	A8A7E7 A1C150 *
X1-D		CAPACITOR, FIXED, MICA: CM05ED300G03, (81349)		EA	REF									3-60	A8A7E7 A1C152 *
X1-D		CAPACITOR, FIXED, MICA: CM05ED330G03, (81349)		EA	20									3-60	A8A7E7 A1C114 *
X1-D		CAPACITOR, FIXED, MICA: CM05ED330G03, (81349)		EA	REF									3-60	A8A7E7 A1C116 *
X1-D		CAPACITOR, FIXED, MICA: CM05ED330G03, (81349)		EA	REF									3-60	A8A7E7 A1C118 *
X1-D		CAPACITOR, FIXED, MICA: CM05ED330G03, (81349)		EA	REF									3-60	A8A7E7 A1C120 *
X1-D		CAPACITOR, FIXED, MICA: CM05ED330G03, (81349)		EA	REF									3-60	A8A7E7 A1C122 *
X1-D		CAPACITOR, FIXED, MICA: CM05ED330G03, (81349)		EA	REF									3-60	A8A7E7 A1C124 *
X1-D		CAPACITOR, FIXED, MICA: CM05ED330G03, (81349)		EA	REF									3-60	A8A7E7 A1C126 *
X1-D		CAPACITOR, FIXED, MICA: CM05ED330G03, (81349)		EA	REF									3-60	A8A7E7 A1C128 *
X1-D		CAPACITOR, FIXED, MICA: CM05ED330G03, (81349)		EA	REF									3-60	A8A7E7 A1C130 *
X1-D		CAPACITOR, FIXED, MICA: CM05ED330G03, (81349)		EA	REF									3-60	A8A7E7 A1C132 *
X1-D		CAPACITOR, FIXED, MICA: CM05ED330G03, (81349)		EA	REF									3-60	A8A7E7 A1C134 *
X1-D		CAPACITOR, FIXED, MICA: CM05ED330G03, (81349)		EA	REF									3-60	A8A7E7 A1C136 *
X1-D		CAPACITOR, FIXED, MICA: CM05ED330G03, (81349)		EA	REF									3-60	A8A7E7 A1C138 *
		*SELECT PER OPERATIONAL REQUIREENT													

****REPAIR PARTS FOR DIRECT SUPPORT, GENERAL SUPPORT, AND DEPOT MAINTENANCE****															
(1) SMR CODE	(2) FEDERAL STOCK NUMBER	(3) DESCRIPTION Reference Number & Mfr. Code Usable on Code		(4) UNIT OF MEAS	(5) 30 DAY DS MAINTENANCE QTY INC IN UNIT	(6) 30 DAY GS MAINTENANCE ALLOWANCE			(7) 1 YR ALW ALLOWANCE			(8) DEPOT MAINT PER 100 EQUIP CNTGCTY	(9) ALW PER 100 EQUIP	(10) ILLUSTRATION	
						(a) 1-20	(b) 21-50	(c) 51-100	(a) 1-20	(b) 21-50	(c) 51-100			(a) FIG NO.	(b) ITEM NO.
X1-D		CAPACITOR, FIXED, MICA CM05ED330G03, (81349)		EA	REF									3-60	A8A7E7 A1C140 *
X1-D		CAPACITOR, FIXED, MICA CM05ED330G03, (81349)		EA	REF									360	A8A7E7 A1C142 *
X1-D		CAPACITOR, FIXED, MICA: CM05ED330G03, (81349)		EA	REF									3-60	A8A7E7 A1C144 *
X1-D		CAPACITOR, FIXED, MICA CM05ED330G03, (81349)		EA	REF									3-60	A8A7E7 A1C116 *
X1-D		CAPACITOR, FIXED, MICA CM05ED330G03, (81349)		EA	REF									3-60	A8A7E7 A1C118 *
X1-D		CAPACITOR, FIXED, MICA CM05ED330G03, (81349)		EA	REF									3-60	A8A7E7 A1C150 *
X1-D		CAPACITOR, FIXED, MICA CM05ED330G03, (81349)		EA	REF									3-60	A8A7E7 A1C152 *
X1-D		CAPACITOR, FIXED, MICA: CM05ED360G03; (81349)		EA	20									360	A8A7E7 A1C112 *
X1-D		CAPACITOR, FIXED, MICA CM05ED360G03; (81349)		EA	REF									360	A8A7E7 A1C16 *
X1-D		CAPACITOR, FIXED, MICA CM05ED360G03, (81349)		EA	REF									3-60	A8A7E7 A1C118 *
X1-D		CAPACITOR, FIXED, MICA CM05ED360G03; (81349)		EA	REF									3-60	A8A7E7 A1C120 *
X1-D		CAPACITOR, FIXED, MICA: CM05ED360G03; (81349)		EA	REF									3-60	A8A7E7 AC122 *
X1-D		CAPACITOR, FIXED, MICA: CM05ED360G03; (81349)		EA	REF									3-60	A8A7E7 A1C124 *
X1-D		CAPACITOR, FIXED, MICA. CM05ED360G03; (81349)		EA	REF									3-60	A8A7E7 A1C126 *
X1-D		CAPACITOR, FIXED, MICA: CM05ED360G03; (81349)		EA	REF									3-60	A8A7E7 A1C128 *
X1-D		CAPACITOR, FIXED, MICA CM05ED360G03; (81349)		EA	REF									3-60	A8A7E7 A1C130 *
X1-D		CAPACITOR, FIXED, MICA CM05ED360G03; (81349)		EA	REF									3-60	A8A7E7 A1C132 *
X1-D		CAPACITOR, FIXED, MICA CM05ED360G03; (81349)		EA	REF									3-60	A8A7E7 A1C134 *
X1-D		CAPACITOR, FIXED, MICA CM05ED360G03; (81349)		EA	REF									3-60	A8A7E7 A1C136 *
X1-D		CAPACITOR, FIXED, MICA. CM05ED360G03; (81349)		EA	REF									3-60	A8A7E7 A1C138 *
X1-D		CAPACITOR, FIXED, MICA: CM05ED360G03; (81349)		EA	REF									3-60	A8A7E7 A1C140 *
X1-D		CAPACITOR, FIXED, MICA. CM05ED360G03; (81349)		EA	REF									3-60	A8A7E7 A1C142 *
X1-D		CAPACITOR, FIXED, MICA: CM05ED360G03; (81349)		EA	REF									3-60	A8A7E7 A1C144 *
X1-D		CAPACITOR, FIXED, MICA CM05ED360G03; (81349)		EA	REF									3-60	A8A7E7 A1C146 *
X1-D		CAPACITOR, FIXED, MICA CM05ED360G03; (81349)		EA	REF									3-6	A8A7E7 A1C148 *
		SELECT PER OPERATIONAL REQUIREMENT													

****REPAIR PARTS FOR DIRECT SUPPORT, GENERAL SUPPORT, AND DEPOT MAINTENANCE****															
(1) SMR CODE	(2) FEDERAL STOCK NUMBER	(3) DESCRIPTION Reference Number & Mfr. Code Usable on Code		(4) UNIT OF MEAS	(5) 30 DAY DS MAINTENANCE QTY INC IN UNIT	(6) 30 DAY GS MAINTENANCE ALLOWANCE			(7) 1 YR ALW ALLOWANCE			(8) DEPOT MAINT PER 100 EQUIP CNTGCTY	(9) ALW PER 100 EQUIP	(10) ILLUSTRATION	
						(a) 1-20	(b) 21-50	(c) 51-100	(a) 1-20	(b) 21-50	(c) 51-100			(a) FIG NO.	(b) ITEM NO.
X1-D		CAPACITOR, FIXED, MICA: CM05ED360G03; (81349)		EA	REF									3-60	A8A7E7 A1C150 *
X1-D		CAPACITOR, FIXED, MICA: CM05ED360G03; (81349)		EA	REF									3-60	A8A7E7 A1C152 *
X1-D		CAPACITOR, FIXED, MICA: CM05ED390G03; (81349)		EA	20									3-60	A8A7E7 A1C114 *
X1-D		CAPACITOR, FIXED, MICA: CM05ED390G03; (81349)		EA	REF									3-60	A8A7E7 A1C116 *
X1-D		CAPACITOR, FIXED, MICA: CM05ED390G03; (81349)		EA	REF									3-60	A8A7E7 A1C118 *
X1-D		CAPACITOR, FIXED, MICA: CM05ED390G03; (81349)		EA	REF									3-60	A8A7E7 A1C120 *
X1-D		CAPACITOR, FIXED, MICA: CM05ED390G03; (81349)		EA	REF									3-60	A8A7E7 A1C122 *
X1-D		CAPACITOR, FIXED, MICA:: CM05ED390G03; (81349)		EA	REF									3-60	A8A7E7 A1C124 *
X1-D		CAPACITOR, FIXED, MICA: CM05ED390G03; (81349)		EA	REF									3-60	A8A7E7 A1C126 *
X1-D		CAPACITOR, FIXED, MICA: CM05ED390G03; (81349)		EA	REF									3-60	A8A7E7 A1C128 *
X1-D		CAPACITOR, FIXED, MICA: CM05ED390G03; (81349)		EA	REF									3-60	A8A7E7 A1C130 *
X1-D		CAPACITOR, FIXED, MICA: CM05ED390G03; (81349)		EA	REF									3-60	A8A7E7 A1C132 *
X1-D		CAPACITOR, FIXED, MICA: CM05ED390G03; (81349)		EA	REF									3-60	A8A7E7 A1C134 *
X1-D		CAPACITOR, FIXED, MICA: CM05ED390G03; (81349)		EA	REF									3-60	A8A7E7 A1C136 *
X1-D		CAPACITOR, FIXED, MICA: CM05ED390G03; (81349)		EA	REF									3-60	A8A7E7 A1C138 *
X1-D		CAPACITOR, FIXED, MICA: CM05ED390G03; (81349)		EA	REF									3-60	A8A7E7 A1C140 *
X1-D		CAPACITOR, FIXED, MICA: CM05ED390G03; (81349)		EA	REF									3-60	A8A7E7 A1C142 *
X1-D		CAPACITOR, FIXED, MICA: CM05ED390G03; (81349)		EA	REF									3-60	A8A7E7 A1C144 *
X1-D		CAPACITOR, FIXED, MICA: CM05ED390G03; (81349)		EA	REF									3-60	A8A7E7 A1C144 *
X1-D		CAPACITOR, FIXED, MICA: CM05ED390G03; (81349)		EA	REF									3-60	A8A7E7 A1C146 *
X1-D		CAPACITOR, FIXED, MICA: CM05ED390G03; (81349)		EA	REF									3-60	A8A7E7 A1C148 *
X1-D		CAPACITOR, FIXED, MICA: CM05ED390G03; (81349)		EA	REF									3-60	A8A7E7 A1C150 *
X1-D		CAPACITOR, FIXED, MICA: CM05ED390G03; (81349)		EA	REF									3-60	A8A7E7 A1C152 *
X1-D		CAPACITOR, FIXED, MICA: CM05ED430G03; (81349)		EA	20									3-60	A8A7E7 A1C114 *
X1-D		CAPACITOR, FIXED, MICA: CM05ED430G03; (81349)		EA	REF									3-60	A8A7E7 A1C116 *
X1-D		CAPACITOR, FIXED, MICA: CM05ED430G03; (81349)		EA	REF									3-60	A8A7E7 A1C118 *
		SELECT PER OPERATIONAL REQUIREMENT													

****REPAIR PARTS FOR DIRECT SUPPORT, GENERAL SUPPORT, AND DEPOT MAINTENANCE****															
(1) SMR CODE	(2) FEDERAL STOCK NUMBER	(3) DESCRIPTION Reference Number & Mfr. Code Usable on Code		(4) UNIT OF MEAS	(5) 30 DAY DS MAINTENANCE QTY INC IN UNIT	(6) 30 DAY GS MAINTENANCE ALLOWANCE			(7) 1 YR ALW ALLOWANCE			(8) DEPOT MAINT PER 100 EQUIP CNTGCTY	(9) ALW PER 100 EQUIP	(10) ILLUSTRATION	
						(a) 1-20	(b) 21-50	(c) 51-100	(a) 1-20	(b) 21-50	(c) 51-100			(a) FIG NO.	(b) ITEM NO.
X1-D		CAPACITOR, FIXED, MICA: CM05ED430G03, (81349)		EA	REF									3-60	A8A7E7 A1C120 *
X1-D		CAPACITOR, FIXED, MICA: CM05ED430G03, (81349)		EA	REF									3-60	A8A7E7 A1C122 *
X1-D		CAPACITOR, FIXED, MICA: CM05ED430G03, (81349)		EA	REF									3-60	ABA7E7 A1C124 *
X1-D		CAPACITOR, FIXED, MICA: CM05ED430G03, (81349)		EA	REF									3-60	A8A7E7 . A1C126 *
X1-D		CAPACITOR, FIXED, MICA:: CM05ED430G03, (81349)		EA	REF									3-60	A8A7E7 A1C128 *
X1-D		CAPACITOR, FIXED, MICA: CM05ED4300O3, (81349)		EA	REF									3-60	A8A7E7 A1C130 *
X1-D		CAPACITOR, FIXED, MICA: CM05ED430G03, (81349)		EA	REF									3-60	A8A7E7 A1C132 *
X1-D		CAPACITOR, FIXED, MICA: CM05ED430G03, (81349)		EA	REF									3-60	A8A7E7 . A1C134 *
X1-D		CAPACITOR, FIXED, MICA: CM05ED430G03, (81349)		EA	REF									3-60	A8A7E7 A1C136 *
X1-D		CAPACITOR, FIXED, MICA: CM05ED430G03, (81349)		EA	REF									3-60	A8A7E7 A1C138 *
X1-D		CAPACITOR, FIXED, MICA: CM05ED430G03, (81349)		EA	REF									3-60	A8A7E7 A1C140 *
X1-D		CAPACITOR, FIXED, MICA: CM05ED430G03, (81349)		EA	REF									3-60	A8A7E7 . A1C142 *
X1-D		CAPACITOR, FIXED, MICA: CM05ED430G03, (81349)		EA	REF									3-60	A8A7E7 A1C144 *
X1-D		CAPACITOR, FIXED, MICA: CM05ED430G03, (81349)		EA	REF									3-60	A8A7E7 A1C146 *
X1-D		CAPACITOR, FIXED, MICA: CM05ED430G03, (81349)		EA	REF									3-60	A8A7E7 A1C148 *
X1-D		CAPACITOR, FIXED, MICA: CM05ED430G03, (81349)		EA	REF									3-60	A8A7E7 . A1C150 *
X1-D		CAPACITOR, FIXED, MICA: CM05ED430G03, (81349)		EA	REF									3-60	A8A7E7 A1C152 *
P-H-S	5820-953-5772	OSCILLATOR SUBASSEMBLY, CRYSTAL: 549-5778-004, (13499)		EA	1				*	*	*	*	*	3-60	A8A7E7A2
X1-D		BOARD, PRINTED CIRCUIT: 549-5780-004, (13499)		EA	1									3-60	A8A7E7 A2E1
P-D	5910-683-7114	CAPACITOR, VARIABLE, GLASS: VC10GWY, (73899)		EA	20							*	*	3-60	A8A7E7 A2C113
P-D	5910-683-7114	CAPACITOR, VARIABLE, GLASS: VC10GWY, (73899)		EA	REF							REF	REF	3-60	A8A7E7 A2C115
P-D	5910-683-7114	CAPACITOR, VARIABLE, GLASS: VC10GWY, (73899)		EA	REF							REF	REF	3-60	A8A7E7 A2C117
P-D	5910-683-7114	CAPACITOR, VARIABLE, GLASS: VC10GWY, (73899)		EA	REF							REF	REF	3-60	A8A7E7 A2C119
P-D	5910-683-7114	CAPACITOR, VARIABLE, GLASS: VC10GWY, (73899)		EA	REF							REF	REF	3-60	A8A7E7 A2C121
P-D	5910-683-7114	CAPACITOR, VARIABLE, GLASS: VC10GWY, (73899)		EA	REF							REF	REF	3-60	A8A7E7 A2C123
* SELECT PER OPERATIONAL REQUIREMENT.															

****REPAIR PARTS FOR DIRECT SUPPORT, GENERAL SUPPORT, AND DEPOT MAINTENANCE****															
(1) SMR CODE	(2) FEDERAL STOCK NUMBER	(3) DESCRIPTION Reference Number & Mfr. Code Usable on Code		(4) UNIT OF MEAS	(5) 30 DAY DS MAINTENANCE QTY INC IN UNIT	(6) 30 DAY GS MAINTENANCE ALLOWANCE			(7) 1 YR ALW ALLOWANCE			(8) DEPOT MAINT PER 100 EQUIP CNTGCTY	(9) ALW PER 100 EQUIP	(10) ILLUSTRATION	
						(a) 1-20	(b) 21-50	(c) 51-100	(a) 1-20	(b) 21-50	(c) 51-100			(a) FIG NO.	(b) ITEM NO.
P-D	5910-683-7114	CAPACITOR, VARIABLE, GLASS: VC10GWY, (73899)		EA	REF							REF	REF	3-60	A8A7E7 A2C125
P-D	5910-683-7114	CAPACITOR, VARIABLE, GLASS: VC10GWY, (73899)		EA	REF							REF	REF	3-60	A8A7E7 A2C127
P-D	5910-683-7114	CAPACITOR, VARIABLE, GLASS: VC10GWY, (73899)		EA	REF							REF	REF	3-60	A8A7E7 A2C129
P-D	5910-683-7114	CAPACITOR, VARIABLE, GLASS: VC10GWY, (73899)		EA	REF							EF	REF	3-60	A8A7E7 A2C131
P-D	5910-683-7114	CAPACITOR, VARIABLE, GLASS: VC10GWY, (73899)		EA	RE							REF	REF	3-60	A8A7E7 A2C133
P-D	5910-683-7114	CAPACITOR, VARIABLE, GLASS: VC10GWY, (73899)		EA	REF							REF	REF	3-60	A8A7E7 A2C135
A2C135 P-D	5910-683-7114	CAPACITOR, VARIABLE, GLASS: VC10GWY, (73899)		EA	REF							REF	REF	3-60	A8A7E7 A2C137
P-D	5910-683-7114	CAPACITOR, VARIABLE, GLASS: VC10GWY, (73899)		EA	REF							REF	REF	3-60	A8A7E7 A2C139
P-D	5910-683-7114	CAPACITOR, VARIABLE, GLASS: VC10GWY, (73899)		EA	REF							REF	REF	3-60	A8A7E7 A2C141
P-D	5910-683-7114	CAPACITOR, VARIABLE, GLASS: VC10GWY, (73899)		EA	REF							REF	REF	360	A8A7E7 A2C143
P-D	5910-683-7114	CAPACITOR, VARIABLE, GLASS: VC10GWY, (73899)		EA	REF							REF	REF	3-60	A8A7E7 A2C145
P-D	5910-683-7114	CAPACITOR, VARIABLE, GLASS: VC10GWY, (73899)		EA	REF							REF	REF	3-60	A8A7E7 A2C147
P-D	5910-683-7114	CAPACITOR, VARIABLE, GLASS: VC10GWY, (73899)		EA	REF							REF	REF	3-60	A8A7E7 A2C119
P-D	5910-683-7114	CAPACITOR, VARIABLE, GLASS: VC10GWY, (73899)		EA	REF							REF	REF	3-60	A8A7E7 A2C151
P-D		CONTACT ARM, NO. 2: 548-7858-003; (13499)		EA	2							*	*		A8A7E7 A2E1
P-D	5310-622-1724	NUT, SELF-LOCKING, HEXAGON: 68-1660-26, (72962)		EA	2							*	*		A8A7E7 A2E1H1
P-D	5310-622-1724	NUT, SELF-LOCKING, HEXAGON: 68-1660-26, (72962)		EA	REF							REF	REF		A8A7E7 A2E1H2
P-D	5305-407-8559	SCREW, MACHINE: P347-010-000, (77250)		EA	2							*	*		A8A7E7 A2E1H3
P-D	5305-407-8559	SCREW, MACHINE: P347-010-000, (77250)		EA	REF							REF	REF		A8A7E7 A2E1H4
P-D		CONTACT ARM, NO 2 548-7858-003, (13499)		EA	REF							REF	REF		A8A7E7 A2E2
P-D	5310-622-1724	NUT, SELF-LOCKING, HEXAGON: 68-1660-26, (72962)		EA	2							REF	REF		A8A7E7 A2E2H1
P-D	5310-622-1724	NUT, SELF-LOCKING, HEXAGON: 681660-26, (72962)		EA	REF							REF	REF		A8A7E7 A2E2H2
P-D	5305-407-8559	SCREW, MACHINE: P347-0104-000, (77250)		EA	2							REF	REF		A8A7E7 A2E2H3
P-D	5305-407-8559	SCREW, MACHINE: P347-0104-000, (77250)		EA	REF							REF	REF		A8A7E7 A2E2H4
P-D	5999-957-8504	CONTACT ASSEMBLY, ELECTRICAL: 756-7600-000, (13499)		EA	2							*	*		A8A7E7 A2E3

****REPAIR PARTS FOR DIRECT SUPPORT, GENERAL SUPPORT, AND DEPOT MAINTENANCE****															
(1) SMR CODE	(2) FEDERAL STOCK NUMBER	(3) DESCRIPTION Reference Number & Mfr. Code Usable on Code		(4) UNIT OF MEAS	(5) 30 DAY DS MAINTENANCE QTY INC IN UNIT	(6) 30 DAY GS MAINTENANCE ALLOWANCE			(7) 1 YR ALW ALLOWANCE			(8) DEPOT MAINT PER 100 EQUIP CNTGCTY	(9) ALW PER 100 EQUIP	(10) ILLUSTRATION	
						(a) 1-20	(b) 21-50	(c) 51-100	(a) 1-20	(b) 21-50	(c) 51-100			(a) FIG NO.	(b) ITEM NO.
P-D		CONTACT ASSEMBLY, ELECTRICAL 756-7600-004, (13499)		EA	REF							REF	REF		A8A7E7 A2E4
P-D	5955-950-8554	CRYSTAL UNIT, QUARTZ: S289-3490-000, (94148)		EA	1							*	*	3-60	A8A7E7 A2Y1
P-D	5955-950-8560	CRYSTAL UNIT, QUARTZ: S289-3491-000, (94148)		EA	1							*	*	3-60	A8A7E7 A2Y2
P-D	5955-950-8561	CRYSTAL UNIT, QUARTZ S289-3492-000, (94148)		EA	1							*	*	3-60	A8A7E7 A2Y3
P-D	5955-950-8568	CRYSTAL UNIT, QUARTZ S289-3493-000, (94148)		EA	1							*	*	3-60	A8A7E7 A2Y4
P-D	5955-950-8562	CRYSTAL UNIT, QUARTZ S289-3494-000, (94148)		EA	1							*	*	3-60	A8A7E7 A2Y5
P-D	5955-950-8563	CRYSTAL UNIT, QUARTZ S289-3495-000, (94148)		EA	1							*	*	3-60	A8A7E7 A2Y6
P-D	5955-950-8564	CRYSTAL UNIT, QUARTZ S289-3496-000, (91,148)		EA	1							*	*	3-60	A8A7E7 A2Y7
P-D	5955-950-8565	CRYSTAL UNIT, QUARTZ S289-3497-000, (94148)		EA	1							*	*	3-60	A8A7E7 A2Y8
P-D	5955-950-8566	CRYSTAL UNIT, QUARTZ: S289-3498-000, (94148)		EA	1							*	*	3-60	A8A7E7 A2Y9
P-D	5955-950-8567	CRYSTAL UNIT, QUARTZ S289-3499-000, (94148)		EA	1							*	*	3-60	A8A7E7 A2Y10
P-D	59559 950-8550	CRYSTAL UNIT, QUARTZ S289-3500-000, (94148)		EA	1							*	*	3-60	A8A7E7 A2Y11
P-D	5955-950-8569	CRYSTAL UNIT, QUARTZ S289-3501-000, (94148)		EA	1							*	*	3-60	A8A7E7 A2Y12
P-D	5955-950-8551	CRYSTAL UNIT, QUARTZ S289-3502-000, (94148)		EA	1							*	*	3-60	A8A7E7 A2Y13
P-D	5955-950-8552	CRYSTAL UNIT, QUARTZ. 289-3503-000, (94148)		EA	1							*	*	3-60	A8A7E7 A2Y14
P-D	5955-950-8553	CRYSTAL UNIT, QUARTZ: S289-3504-000, (94148)		EA	1							*	*	3-60	A8A7E7 A2Y15
P-D	5955-950-8554	CRYSTAL UNIT, QUARTZ S289-3505-000, (94148)		EA	1							*	*	3-60	A8A7E7 A2Y16
P-D	5955-950-8555	CRYSTAL UNIT, QUARTZ S289-3506-000, (94148)		EA	1							*	*	3-60	A8A7E7 A2Y17
P-D	5955-950-8556	CRYSTAL UNIT, QUARTZ S289-3507-000, (94148)		EA	1							*	*	3-60	A8A7E7 A2Y18
P-D	5955-950-8557	CRYSTAL UNIT, QUARTZ S289-3508-000, (94148)		EA	1							*	*	3-60	A8A7E7 A2Y19
P-D	5955-950-8558	CRYSTAL UNIT, QUARTZ- S289-3509-000, (94148)		EA	1							*	*	3-60	A8A7E7 A2Y20
P-D	5365-159-3714	DISK, SUPPORT. 549-5843-002, (13499)		EA	2							*	*		A8A7E7 A2MP1
P-D		DISK, SUPPORT 549-5843-002, (13499)		EA	REF							REF	REF		A8A7E7 A2MP2
P-D	5999-165-3691	RETAINER, SWITCH 549-5737-002, (13499)		EA	4							*	*		A8A7E7 A2MP3
P-D		RETAINER, SWITCH 549-5737-002, (13499)		EA	REF							REF	REF		A8A7E7 A2MP4

REPAIR PARTS FOR DIRECT SUPPORT, GENERAL SUPPORT, AND DEPOT MAINTENANCE (Continued)															
(1) SMR CODE	(2) FEDERAL STOCK NUMBER	(3) DESCRIPTION Reference Number & Mfr. Code Usable on Code		(4) UNIT OF MEAS	(5) QTY INC IN UNIT	(6) 30 DAY DS MAINTENANCE ALLOWANCE			(7) 30 DAY GS MAINTENANCE ALLOWANCE			(8) 1 YR ALW PER 100 EQUIP CNTGCTY	(9) DEPOT MAINT ALW PER 100 EQUIP	(10) ILLUSTRATION	
						(a)	(b)	(c)	(a)	(b)	(c)			(a) FIG NO.	(b) ITEM NO. OR REFERENCE DESIGNATION
						1-20	21-50	51-100	1-20	21-50	51-100				
P-D	5999-165-3691	RETAINER, SWITCH 549-5737-002, (13499)		EA	REF							REF	REF		A8A7E7A2MPS
P-D		RETAINER, SWITCH. 549-3737-002, (13499)		EA	REF							REF	REF		A8A7E7A2MP6
M-D		SPACER, PLATE 756-4171-002, (13499)		EA	2										A8A7E7A2MP7
M-D		SPACER, PLATE 756-4171-002, (13499)		EA	REF										A8A7E7A2MP8
M-D		SPACER, SLEEVE 549-5735-002, (13499)		EA	2										A8A7E7A2MP9
M-D		SPACER, SLEEVE 549-5735-002, (13499)		EA	REF										A8A7E7A2MP10
P-HR-	5820-975-5422	CONVERTER, FREQUENCY, ELECTRICAL- 549-5801-004, (13499)		EA	1				*	*	*	*	*	3-14	A8A7E6
X1-D		BOARD, PRINED CIRCUIT: 549-5803-004; (13499)		EA	1									3-59	A8A7E6E1
X1-D		CAPACITOR, FIXED, CERAMIC- 20C91A, (56289)		EA	3									3-57	A8A7E6C96
X1-D		CAPACITOR, FIXED, CERAMIC. 20C91A, (56289)		EA	REF									3-59	A8A7E6C98
X1-D		CAPACITOR, FIXED, CERAMIC 20C91A; (56289)		EA	REF									3-59	A8A7E6C111
X1-D		CAPACITOR, FIXED, CERAMIC. 6S8082, (56289)		EA	3									3-59	A8A7E6C94
X1-D		CAPACITOR, FIXED, CERAMIC. 6S8082, (56289)		EA	REF									3-59	A8A7E6C102
X1-D		CAPACITOR, FIXED, CERAMIC 6S8082, (56289)		EA	REF									3-59	A8A7E6C112
X1-D		CAPACTTOR, FIXED, MICA- CM05CD050D03, (81349)		EA	2									3-59	A8ATE6C100
X1-D		CAPACITOR, FIXED, MICA: CM05CD050D03, (81349)		EA	REF									3-59	A8A7E6C101
X1-D		CAPACITOR, FIXED, MICA: CM05ED390J03; (81349)		EA	3									3-59	A8A7E6C104
X1-D		CAPACITOR, FIXED, KICA- CM05ED390J03, (81349)		EA	REF									3-59	A8A7E6C106
X1-D		CAPACITOR, FIXED, MICA: CM05ED390J03, (81349)		EA	REF									3-59	A8A7E6C108
X1-D		CAPACITOR, FIXED, MICA- CM05FD181C03, (81349)		EA	2									3-59	A8A7E6C97
X1-D		CAPACITOR, FIXED, MICA- CM05FD181G03, (81349)		EA	REF									3-59	A8A7E6C99
X1-D		CAPACITOR, FIXED, MICA: CM05FD221J03, (81349)		EA	3									3-59	A8A7E6C105
X1-D		CAPACITOR, FIXED, MICA CM05FD221J03, (81349)		EA	REF									3-59	A8A7E6C107
X1-D		CAPACITOR, FIXED, MICA- CM05FD221J03, (81349)		EA	RE									3-59	A8A7E6C119
X1-D		CAPACITOR, FIXED, MICA: CM05FD241J03, (81349)		EA	1									3-59	A8A7E6C103

REPAIR PARTS FOR DIRECT SUPPORT, GENERAL SUPPORT, AND DEPOT MAINTENANCE (Continued)															
(1) SMR CODE	(2) FEDERAL STOCK NUMBER	(3) DESCRIPTION Reference Number & Mfr. Code Usable on Code		(4) UNIT OF MEAS	(5) QTY INC IN UNIT	(6) 30 DAY DS MAINTENANCE ALLOWANCE			(7) 30 DAY GS MAINTENANCE ALLOWANCE			(8) 1 YR ALW PER 100 EQUIP CNTGCTY	(9) DEPOT MAINT ALW PER 100 EQUIP	(10) ILLUSTRATION	
						(a)	(b)	(c)	(a)	(b)	(c)			(a) FIG NO.	(b) ITEM NO. OR REFERENCE DESIGNATION
						1-20	21-50	51-100	1-20	21-50	51-100				
X1-D		CAPACITOR, FIXED, MICA: DM15F511J300WV4CR; (72136)		EA	2									3-59	A8A7E6C95
X1-D		CAPACITOR, FIXED, MICA: DM15F511J300WV4CR; (72136)		EA	REF									3-59	A8A7E6C156
X1-D		COIL, RADIO FREQUENCY: LT10K020, (81349)		EA	4									359	A8A7E6L23
X1-D		COIL, RADIO FREQUENCY: LT10K020; (8134 9)		EA	REF									3-59	A8A7E6L24
X1-D		COIL, RADIO FREQUEICY: LT10K020, (81349)		EA	REF									3-59	A8A7E6L25
X1-D		COIL, RADIO FREQUENCY: LT10K020; (81349)		EA	REF									3-59	A8A7E6L26
X1-D		COIL, RADIO FREQUECY: LT10K036, (81349)		EA	2									3-59	A8A7E6L21
X1-D		COIL, RADIO FREQUENCY: LT10K036; (81349)		EA	REF									3-59	A8A7E6L22
X1-D		HOLDER, TRANSISTOR: A51048; (08289)		EA	1										A8A7E6MP1
X1-D		JACK, TIP: 105-738-100, (74970)		EA	1									3-59	A8A7E6J1
X1-D		RESISTOR, FIXED, COMPOSITION: RCR07G121KS, (81349)		EA	1									3-59	A8A7E6R118
X1-D		RESISTOR, FIXED, COMPOSITION: RCR07G102KS; (81349)		EA	1									3-59	A8A7T6R117
X1-D		RESISTOR, FIXED, COMPOSITION: RCR07G272ES; (81349)		EA	1									3-59	A8A7E6R116
X1-D		RESISTOR, FIXED, COMPOSITION: RCR07G183KS, (81349)		EA	1									3-59	A8A7E6R113
X1-D		RESISTOR, FIXED, COMPOSITION: RCR07G223KS, (81349)		EA	1									3-59	A8A7E6R112
X1-D		RESISTOR, FIXED, COMPOSITION: RCR07G273KS; (81349)		EA	1									3-59	A8A7E6R114
X1-D		RESISTOR, FIXED, COMPOSITION: RCR07G333KS, (81349)		EA	1									3-59	A8A7E6R115
X1-D		RESISTOR, FIXED, COMPOSITION: RCR07G393KS; (81349)		EA	6									3-59	A8A7E6R105
X1-D		RESISTOR, FIXED, COMPOSITION: RCR07G393XS, (81349)		EA	REF									3-59	A8A7E6R106
X1-D		RESISTOR, FIXED, COMPOSITION: RCR07G393KS, (81349)		EA	REF									3-59	A8A7E6R107
X1-D		RESISTOR, FIXED, COMPOSITION: RCR070393KS, (81349)		EA	REF									3-59	A8A7E6R108
X1-D		RESISTOR, FIXED, COMPOSITION: RCR07G393KS; (81349)		EA	REF									3-59	A8A7E6R109
X1-D		RESISTOR, FIXED, COMPOSITION: RCR07G393KS, (81349)		EA	REF									3-59	A8A7E6R110
X1-D		RESISTOR, FIXED, COMPOSITION: RCR07G683KS, (81349)		EA	1									3-59	A8A7E6R111
X1-D		SEMICONDUCTOR DEVICE, DIODE 1N916, (07688)		EA	2									3-59	A8A7E6CR7

SECTION II

TM 11-5820-509-35

REPAIR PARTS FOR DIRECT SUPPORT, GENERAL SUPPORT, AND DEPOT MAINTENANCE (Continued)															
(1) SMR CODE	(2) FEDERAL STOCK NUMBER	(3) DESCRIPTION Reference Number & Mfr. Code Usable on Code		(4) UNIT OF MEAS	(5) QTY INC IN UNIT	(6) 30 DAY DS MAINTENANCE ALLOWANCE			(7) 30 DAY GS MAINTENANCE ALLOWANCE			(8) 1 YR ALW PER 100 EQUIP CNTGCTY	(9) DEPOT MAINT ALW PER 100 EQUIP	(10) ILLUSTRATION	
						(a)	(b)	(c)	(a)	(b)	(c)			(a) FIG NO.	(b) ITEM NO. OR REFERENCE DESIGNATION
						1-20	21-50	51-100	1-20	21-50	51-100				
X1-D		SEMICONDUCTOR DEVICE, DIODE: 1N916, (07688)		EA	REF									3-59	A8A7E6CR8
X1-D		TRANSISTOR: 2N697, (07688)		EA	1									3-59	A8A7E6Q23
X1-D		TRANSISTOR: 2N703, (07688)		EA	3									3-59	A8A7E6Q20
X1-D		TRANSISTOR: 2N703; (07688)		EA	REF									3-59	A8A7E6Q21
X1-D		TRANSISTOR: 2N703, (07688)		EA	REF									3-59	A8A7E6Q22
M-D		COVER, FILTER: 756-0317-003; (13499)		EA	1										A8A7MP7
P-D	5305-206-1270	SCREW, MACHINE: P343-0284-000; (77250)		EA	2							*	*		A8A7MP7H1
P-D	5305-206-1270	SCREW, MACHINE: P343-0284-000, (77250)		EA	REF							REF	REF		A8A7MP7H2
P-D	5310-184-8996	WASHER, SPRING TENSION: 310-0396-00; (79807)		EA	2							*	*		A8A7MP7H3
P-D	5310-184-8996	WASHER, SPRING TENSION: 310-0396-00; (79807)		EA	REF							REF	REF		A8A7MP7H4
M-D		COVER, OSCILLATOR CONTROL: 548-7762-003; (13499)		EA	1										A8A7MP8
P-D	5305-054-5647	SCREW, MACHINE: MS51957-13, (96906)		EA	11							*	*		A8A7MP8H1
P-D	5305-054-5647	SCREW, MACHINE: MS51957-13; (96906)		EA	REF							REF	REF		A8A7MP8H2
P-D	5305-054-5647	SCREW, MACHINE: MS51957-13, (96906)		EA	REF							REF	REF		A8A7MP8H3
P-D	5305-054-5647	SCREW, MACHINE: MS51957-13, (96906)		EA	REF							REF	REF		A8A7MP8H4
P-D	5305-054-5647	SCREW, MACHINE: MS51957-13, (96906)		EA	REF							REF	REF		A8A7MP8H5
P-D	5305-054-5647	SCREW, MACHINE: MS51957-13, (96906)		EA	REF							REF	REF		A8A7MP8H6
P-D	5305-054-5647	SCREW, MACHINE: MS51957-13, (96906)		EA	REF							REF	REF		A8A7MP8H7
P-D	5305-054-5647	SCREW, MACHINE: MS51957-13, (96906)		EA	REF							REF	REF		A8A7MP8H8
P-D	5305-054-5647	SCREW, MACHINE: MS51957-13, (96906)		EA	REF							REF	REF		A8A7MP8H9
P-D	5305-054-5647	SCREW, MACHINE: MS51957-13, (96906)		EA	REF							REF	REF		A8A7MP8H10
P-D	5305-054-5647	SCREW, MACHINE: MS51957-13, (96906)		EA	REF							REF	REF		A8A7MP8H11
P-D		WASHER, LOCK, SPRING: MS35338-135, (96906)		EA	11							REF	REF		A8A7MP8H12
P-D		WASHER, LOCK, SPRING: M4S35338-135, (96906)		EA	REF							REF	REF		A8A7MPHF13
P-D		WASHER, LOCK, SPRING: MS35338-135, (96906)		EA	REF							REF	REF		A8A7MPNH14

REPAIR PARTS FOR DIRECT SUPPORT, GENERAL SUPPORT, AND DEPOT MAINTENANCE (Continued)															
(1) SMR CODE	(2) FEDERAL STOCK NUMBER	(3) DESCRIPTION Reference Number & Mfr. Code Usable on Code		(4) UNIT OF MEAS	(5) QTY INC IN UNIT	(6) 30 DAY DS MAINTENANCE ALLOWANCE			(7) 30 DAY GS MAINTENANCE ALLOWANCE			(8) 1 YR ALW PER 100 EQUIP CNTGCTY	(9) DEPOT MAINT ALW PER 100 EQUIP	(10) ILLUSTRATION	
						(a)	(b)	(c)	(a)	(b)	(c)			(a)	(b)
						1-20	21-50	51-100	1-20	21-50	51-100			FIG NO.	ITEM NO. OR REFERENCE DESIGNATION
P-D		WASHER, LOCK, SPRING: MS35338-135; (96906)		EA	REF							REF	REF	A8A7MP8H15	
P-D		WASHER, LOCK, SPRING: MS35338-135, (96906)		EA	REF							REF	REF	A8A7MP8H16	
P-D		WASHER, LOCK, SPRING: MS35338-135; (96906)		EA	REF							REF	REF	A8A7MP8H17	
P-D		WASHER, LOCK, SPRING: MS35338-135, (96906)		EA	REF							REF	REF	A8A7MP8H18	
P-D		WASHER, LOCK, SPRING: MS35338-135, (96906)		EA	REF							REF	REF	A8A7MP8H19	
P-D		WASHER, LOCK, SPRING: MS35338-135; (96906)		EA	REF							REF	REF	A8A7MP8H20	
P-D		WASHER, LOCK, SPRING: MS35338-135; (96906)		EA	REF							REF	REF	A8A7MP8H21	
P-D		WASHER, LOCK, SPRING: MS35338-135; (96906)		EA	REF							REF	REF	A8A7MP8H22	
P-H-T	5820-975-5423	DISCRIMINATOR, PHASEANDFREQUENCY 549-5794-004, (13499)		EA	1			*	*	*	*	*	3-14	A8A7E2	
X1-D		BOARD, PRINTED CIRCUIT: 549-57T1-003; (13499)		EA	1								3-55	A8A7E2E2	
X1-D		CAPACITOR, FIXED, CERAMIC: 658082, (56289)		EA	2									A8A7E2C22	
X1-D		CAPACITOR, FIXED, CERAMIC: 6S8082, (56289)		EA	REF								3-55	A8A7E2C30	
X1-D		CAPACITOR, FIXED, CERAMIC: 658083, (56289)		EA	6								3-55	A8A7E2C23	
X1-D		CAPACITOR, FIXED, CERAMIC: 6S8083, (56289)		EA	REF								3-55	A8A7E2C25	
X1-D		CAPACITOR, FIXED, CERAMIC: 658083, (56289)		EA	REF								3-55	A8A7E2C29	
X1-D		CAPACITOR, FIXED, CERAMIC: 658083, (56289)		EA	REF								3-55	A8A7E2C32	
X1-D		CAPACITOR, FIXED, CERAMIC: 658083; (56289)		EA	REF								3-55	A8A7E2C35	
X1-D		CAPACITOR, FIXED, CERAMIC: 658083; (56289)		EA	REF								3-55	A8A7E2C36	
X1-D		CAPACITOR, FIXED, ELECTROLYTIC: 150D335X0035B2; (56289)		EA	1								3-55	A8A7E2C26	
X1-D		CAPACITOR, FIXED, ELECTROLYTIC: 150D10X0035A2, (56289)		EA	2								3-55	A8A7E2C92	
X1-D		CAPACITOR, FIXED, ELECTROLYTIC: 150D104X0035A2; (56289)		EA	REF								3-55	A8A7E2C93	
X1-D		CAPACITOR, FIXED, MICA: CM05FD151J03, (81349)		EA	2								3-55	A8A7E2C28	
X1-D		CAPACITOR, FIXED, MICA: CM405FD151J03; (81349)		EA	REF								3-55	A8A7E2C34	
X1-D		CAPACITOR, FIXED, MICA: CMN5FD271J03; (81349)		EA	2								3-55	A8A7E2C27	
X1-D		CAPACITOR, FIXED, MICA: CM405FD271J03; (81349)		EA	REF								3-55	A8A7E2C33	

SECTION II

TM 11-5820-509-35

REPAIR PARTS FOR DIRECT SUPPORT, GENERAL SUPPORT, AND DEPOT MAINTENANCE (Continued)															
(1) SMR CODE	(2) FEDERAL STOCK NUMBER	(3) DESCRIPTION Reference Number & Mfr. Code Usable on Code		(4) UNIT OF MEAS	(5) QTY INC IN UNIT	(6) 30 DAY DS MAINTENANCE ALLOWANCE			(7) 30 DAY GS MAINTENANCE ALLOWANCE			(8) 1 YR ALW PER 100 EQUIP CNTGCTY	(9) DEPOT MAINT ALW PER 100 EQUIP	(10) ILLUSTRATION	
						(a)	(b)	(c)	(a)	(b)	(c)			(a) FIG NO.	(b) ITEM NO. OR REFERENCE DESIGNATION
						1-20	21-50	51-100	1-20	21-50	51-100				
P--D		RESISTOR, FIXED, COMPOSITION: RCR07G470KS; (81349)		EA	1							*	*	3-56	A8A7TB1R124
P--D		RESISTOR, FIXED, COMPOSITION: RCR070680KS; (81349)		EA	1							*	*	3-56	A8A7TB1R135
P--D	5905-104-8363	RESISTOR, FIXED, COMPOSITION: RCR07G820KS; (81349)		EA	1							*	*	3-54	A8A7TB1R144*
P--D		RESISTOR, FIXED, COMPOSITION: RCR07G101KS; (81349)		EA	1							*	*	3-56	A8A7TB1R131
P--D		RESISTOR, FIXED, COMPOSITION: RCR07G151KS; (81349)		EA	1							*	*	3-56	A8A7TB1R144*
P--D		RESISTOR, FIXED, COMPOSITION: RCR070221KS; (81349)		EA	2							*	*	3-56	A8A7TB1R139
P--D		RESISTOR, FIXED, COMPOSITION: RCR0TG221KS; (81349)		EA	REF							REF	REF	3-56	A8A7TB1R144*
P--D		RESISTOR, FIXED, COMPOSITION: RCR07G331KS; (81349)		EA	1							*	*	3-56	A8A7TB1R144*
P--D	5905-120-9154	RESISTOR, FIXED, COMPOSITION: RCR07G471KS; (81349)		EA	1							*	*	3-56	A8A7TB1R144*
P--D	5905-135-6046	RESISTOR, FIXED, COMPOSITION: RCR0TG681KS; (81349)		EA	2							*	*	3-56	A8A7TB1R142
P--D		RESISTOR, FIXED, COMPOSITION: RCR0TG681KS; (81349)		EA	REF							REF	REF	3-56	A8A7TB1R144*
P--D		RESISTOR, FIXED, COMPOSITION: RCRC7G821KS; (81349)		EA	1							*	*	3-56	A8A7TB1R144*
P--D		RESISTOR, FIXED, COMPOSITION: RCR07G02XS; (81349)		EA	5							*	*	3-56	ASA7TBIR120
P--D		RESISTOR FIXED, COMPOSITION: RCR07C102KS; (81349)		EA	REF							REF	REF	3-56	A8A7TBIR144*
P--D		RESISTOR, FIXED, COMPOSITION: RCR7cG102KS; (81349)		EA	REF							REF	REF	3-56	A8A7TB1R145
P--D		RESISTOR, FIXED, COMPOSITION: RCR07G102KS; (81349)		EA	REF							REF	REF	3-56	A8A7TB1R146
P--D		RESISTOR, FIXED, COMPOSITION: RCR07G102KS; (81349)		EA	REF							REF	REF	3-56	A8A7TB1R147
P--D		RESISTOR, FIXED, COMPOSITION: RCR07G152KS; (81349)		EA	2								*	3-56	A8A7TB1R143
P--D		RESISTOR, FIXED, COMPOSITION: RCR07G152KS; (813*9)		EA	REF							REF	REF	3-56	A8A7TB1R144*
P--D		RESISTOR, FIXED, COMPOSITION: RCR07G222KS; (81349)		EA	1							*		3-56	A8A7TB1R123
P--D	5905-686-4527	RESISTOR, FIXED, COMPOSITION: RCR07G272KS; (81349)		EA	1							*	*	3-56	A8A7TB1R134
P--D	5905-070-9391	RESISTOR, FIXED, COMPOSITION: RCR07G392KS; (81349)		EA	1							*	*	3-56	A8A7TB1R141
P--D		RESISTOR, FIXED, COMPOSITION: RCR07G472KS; (81349)		EA	2							*	*	3-56	A8A7TB1R119
P--D		RESISTOR, FIXED, COMPOSITION: RCR07G72KS; (81349)		EA	REF							REF	REF	3-56	A8A7TB1R130
P--D	5905-070-9392	RESISTOR, FIXED, COMPOSITION: RCR07G562KS; (81349) *SELECT PER OPERATIONAL REQUIREMENT		EA	1							*	*	3-56	A8A7TB1R151

SECTION II

TM 11-5820-509-35

REPAIR PARTS FOR DIRECT SUPPORT, GENERAL SUPPORT, AN DEPOT MAINTENANCE (Continued)															
(1) SMR CODE	(2) FEDERAL STOCK NUMBER	(3) DESCRIPTION Reference Number & Mfr. Code Usable on Code		(4) UNIT OF MEAS	(5) QTY INC IN UNIT	(6) 30 DAY DS MAINTENANCE ALLOWANCE			(7) 30 DAY GS MAINTENANCE ALLOWANCE			(8) 1 YR ALW PER 100 EQUIP CNTGCTY	(9) DEPOT MAINT ALW PER 100 EQUIP	(10) ILLUSTRATION	
						(a) 1-20	(b) 21-50	(c) 51-100	(a) 1-20	(b) 21-50	(c) 51-100			(a) FIG NO.	(b) ITEM NO. OR REFERENCE DESIGNATION
P--D		RESISTOR, FIXED, COMPOSITION: RCR07G822KS; (81349)		EA	1							*	*	3-56	A8A7TB1R140
P--D	5905-816-8554	RESISTOR, FIXED, COMPOSITION: RCR07GC103KS, (81349)		EA	1							*	*	3-56	A8A7TB1R127
P--D	5905-686-4529	RESISTOR, FIXED, COMPOSITION: RCR07G123KS, (81349)		EA	1							*	*	3-56	A8A7TB1R128
P--D		RESISTOR, FDXED, COMPOSITION: RCR07G223KS, (81349)		EA	3							*	*	3-56	A8A7TB1R129
P--D		RESISTOR, FIXED, COMPOSITION: RCR07G223KS, (81349)		EA	REF							REF	REF		A8A7TB1R136
P--D		RESISTOR, FIXED, COMPOSITION- RCR07G223KS; (81349)		EA	REF							REF	REF	3-56	A8A7TB1R137
P--D	5905-752-3157	RESISTOR, FIXED, COMPOSITION: RCR07C273KS, (81349)		EA	1							*	*	3-56	A8A7TB1R148
P--D		RESISTOR, FIXED, COMPOSITION: RCR07G683KS, (81349)		EA	2							REF	REF	3-56	A8A7TB1R121
P--D		RESISTOR, FIXED, COMPOSITION: RCR007683xc, (81349)		EA	REF							REF	REF	3-56	A8A7TB1R122
P--D	5905-988-2310	RESISTOR, FIXED, FIIM: RN60D1000F, (81349)		EA								*	*	3-56	A8A7TB1R125
P--D	5905-988-2310	RESISTOR, FDE-, FIIM. RN60D1000F; (81349)		EA	REF							REF	REF	3-56	A8A7TB1R126
P--D	5905-988-2310	RESISTOR, FIXED, FIIX: RN60D1000F, (81349)		EA	REF							REF	REF	3-56	A8A7TB1R132
P--D	5905-988-2310	RESISTOR, FIXED, FILM: RN60D1000F, (81349)		EA	REF							REF	REF	3-56	A8A7TB1R133
P--D	5905-781-8015	RESISTOR, FIXED, FILM: RN60D3800F; (81349)		EA	1							*	*	3-56	A8A7TB1R149
P--D	5905-985-5465	RESISTOR, FIXED, FILM: RN60D1962F, (81349)		EA	1							*	*	3-56	A8A7TB1R150
P--D		SEMICONDUCTOR DEVICE, DIODE: 1N198, (07688)		EA	2							*	*	3-56	A8A7TB1CR12
P--D		SEMICONDUCTOR DEVICE, DIODE: 1N198, (07688)		EA	REF							REF	REF	3-56	A8A7TB1CR13
P--D	5961-752-5230	SEMICONDUCTOR DEVICE, DIODE: 1N916, (07688)		EA	2							*	*	3-56	A8A7TB1CR15
P--D	5961-752-5230	SEMICONDUCTOR DEVICE, DIODE: 1N916; (07688)		EA	REF							REF	REF	3-56	A8A7TBICR9
P--D		S1MICONDUCTOR DEVICE, DIODE: JAMIN754A, (81350)		EA	1							*	*	3-56	A8A7TBICR14
P--D	5961-724-6164	SEMICONDUCTOR DEVICE, DIODE: FA4092, (07263)		EA	2							*	*	3-56	A8A7TBICR10
P--D	5961-724-6164	SEMICONDUCTDR DEVICE, DIODE: FA4092, (07263)		EA	REF							REF	REF	3-56	A8A7TB1CR11
P--D	5940-423-2988	TERMINAL, STUD-GROUND: AB397-2, (12615)		EA	17								*	*	A8A7TB1E2
P--D	5310-934-9740	NUT, PLAIN, HBXAGON: MS35649-225; (96906)		EA	1								*	*	A8A7TB1E2H1
P--D	5310-18-8990	WASHER, SPRING TENSION: 310-0075-000; (79807)		EA	1							*	*	*	A8A7TB1E2H2

SECTION II

TM 11-5820-509-35

REPAIR PARTS FOR DIRECT SUPPORT, GENERAL SUPPORT, AND DEPOT MAINTENANCE (Continued)															
(1) SMR CODE	(2) FEDERAL STOCK NUMBER	(3) DESCRIPTION Reference Number & Mfr. Code Usable on Code		(4) UNIT OF MEAS	(5) QTY INC IN UNIT	(6) 30 DAY DS MAINTENANCE ALLOWANCE			(7) 30 DAY GS MAINTENANCE ALLOWANCE			(8) 1 YR ALW PER 100 EQUIP CNTGCTY	(9) DEPOT MAINT ALW PER 100 EQUIP	(10) ILLUSTRATION	
						(a)	(b)	(c)	(a)	(b)	(c)			(a) FIG NO.	(b) ITEM NO. OR REFERENCE DESIGNATION
						1-20	21-50	51-100	1-20	21-50	51-100				
P--D		TERMINAL, STUD-GROUND: AB397-2, (12615)		EA	REF								REF	REF	A8A7TB1E3
P--D	5310-934-9740	NUT, PLAIN, HEXAGON: MS35649-225, (96906)		EA	1								REF	REF	A8A7TB1E3H1
P--D	5310-680-5557	WASHER, SPRING TENSION: 310-0075-000, (79807)		EA	1								REF	REF	A8A7TB1E3H2
P--D		TERMINAL, STUD-GROUND: AB397-2, (12615)		EA	REF								REF	REF	A8A7TB1E4
P--D	5310-934-9740	NUT, PLAIN, HEXAGON: MS35649-225, (96906)		EA	1								REF	REF	A8A7TB1E4H1
P--D	5310-680-5557	WASHER, SPRING TENSION: 310-0075-000, (79807)		EA	1								REF	REF	A8A7TB1E4H2
P--D		TERMINAL, STUD-GROUND: AB397-2, (12615)		EA	REF								REF	REF	A8A7TB1E5
P--D	5310-934-9740	NUT, PLAIN, HEXAGON: MS35649-225, (96906)		EA	1								REF	REF	A8A7TB1E5H1
P--D	5310-680-5557	WASER, SPRING TENSION: 310-0075-000, (79807)		EA	1								REF	REF	A8A7TB1E5H2
P--D		TERMIINAL, STUD-GROUND: AB397-2, (12615)		EA	REF								REF	REF	ABA7TB1E6
P--D	5310-934-9740	NUT, PLAIN, HEXAGON: MS35649-225, (96906)		EA	1								REF	REF	A8A7TB1E6H1
P--D	5310-680-5557	WASHER, SPRING TENSION: 310-0075-000, (79807)		EA	1								REF	REF	A8A7TB1E6H2
P--D		TERMINAL, STUD-GROUND: AB397-2, (12615)		EA	REF								REF	REF	A8A7TB1E7
P--D	5310-934-9740	NUT, PLAIN, HEXAGON: MS35649-225, (96906)		EA	1								REF	REF	A8A7TB1E7H1
P--D	5310-680-5557	WASHER, SPRING TENSION: 310-0075-000, (79807)		EA	1								REF	REF	A8A7TB1E7H2
P--D		TERMINAL, STUD-GROUND: AB397-2, (12615)		EA	REF								REF	REF	A8A7TB1E8
P--D	5310-934-9740	NUT, PLAIN, HEXAGON: MS35649-225, (96906)		EA	1								REF	REF	A8A7TB1E8H1
P--D	5310-680-5557	WASHER, SPRING TENSION: 310-0075-000, (79807)		EA	1								REF	REF	A8A7TB1E8H2
P--D		TERMINAL, STUD-GROUND: AB397-2, (12615)		EA	REF								REF	REF	A8A7TB1E9
P--D	531093-9-9740	NUT, PLAIN, HEXAGON: MS35649-225, (96906)		EA	1								REF	REF	A8A7TB1E9H1
P--D	5310-680-5557	WASHER, SPRING TENSION: 310-0075-000, (79807)		EA	1								REF	REF	A8A7TB1E9H2
P--D		TERMINAL, STUD-GROUND: AB397-2, (12615)		EA	REF								REF	REF	A8A7TB1E10
P--D	5310-93h-9740	NUT, PLAIN, HEXAGON: MS35649-225, (96906)		EA	1								REF	REF	A8A7TB1E10H1
P--D	5310-680-5557	WASHER, SPRING TENSION: 310-0075-000, (79807)		EA	1								REF	REF	A8A7TB1E10H2
P--D	AB397-2, (12615)	TERMINAL, STUD-GROUND:		EA	REF								REF	REF	A8A7TB1E11

REPAIR PARTS FOR DIRECT SUPPORT, GENERAL SUPPORT, AND DEPOT MAINTENANCE (Continued)															
(1) SMR CODE	(2) FEDERAL STOCK NUMBER	(3) DESCRIPTION Reference Number & Mfr. Code Usable on Code		(4) UNIT OF MEAS	(5) QTY INC IN UNIT	(6) 30 DAY DS MAINTENANCE ALLOWANCE			(7) 30 DAY GS MAINTENANCE ALLOWANCE			(8) 1 YR ALW PER 100 EQUIP CNTGCTY	(9) DEPOT MAINT ALW PER 100 EQUIP	(10) ILLUSTRATION	
						(a) 1-20	(b) 21-50	(c) 51-100	(a) 1-20	(b) 21-50	(c) 51-100			(a) FIG NO.	(b) ITEM NO. OR REFERENCE DESIGNATION
P--D	5310-934-9740	NUT, PLAIN, HEXAGON: MS35649-225, (96906)		EA	1							REF	REF		ASA7TB1E11H1
P--D	5310-680-5557	WASHER, SPRING TENSION: 310-0075-000, (79807)		EA	1							REF	REF		A8A7TB1E11H2
P--D		TETBONAL, STUD-GROUND: AB397-2, (12615)		EA	REF							REF	REF		A8A7TB1E12
P--D	5310-934-9740	NUT, PLAIN, HEXAGON: MS35649-225, (96906)		EA	1							REF	REF		A8A7TB1E12H1
P--D	5310-680-5557	WASHER, SPRING TENSION: 310-0075-000, (79807)		EA	1							REF	REF		A8A7TB1E12H2
P--D		TERKMNAL, STUD-GROUND: AB397-2, (12615)		EA	REF							REF	REF		A8A7TB1E13
P--D	5310-934-9740	NUT, PLAIN, HEXAGON: MS35649-225, (96906)		EA	1							REF	REF		A8SATB1E13H1
P--D	5310-680-5557	WASHER, SPRING TENSION: 310-0075-000, (79807)		EA	1							REF	REF		A8A7TB1E13H2
P--D		TENIAL, STUD-GROUND: AB397-2, (12615)		EA	REF							REF	REF		A8A7TB1E14
P--D	5310-934-9740	NUT, PLAIN, HEXAGON: MS35649-225, (96906)		EA	1							REF	REF		A8A7TB1E4H1
P--D	5310-680-5557	WASHER, SPRING TENSION: 310-0075-000, (79807)		EA	1							REF	REF		A8A7TB1E14H2
P--D		TERMINAL, STUD-GROUND: AB397-2, (12615)		EA	REF							REF	REF		A8A7TB1E15
P--D	5310-934-9740	NUT, PLAIN, HXAGON: MS35649-225, (96906)		EA	1							REF	REF		A8A7TB1E15H1
P--D	5310-680-5557	WASHER, SPRING TENSION: 310-0075-000, (79807)		EA	1							REF	REF		A8A7TB1E15H2
P--D		TERMINAL, STUD-GROUND: AB397-2, (12615)		EA	REF							REF	REF		A8A7TB1E16
P--D	5310-934-9740	NUT, PLAIN, HEXAGON: M6356L9-225, (96906)		EA	1							REF	REF		A8A7TB1E16H1
P--D	5310-680-5557	WASHER, SPRING TENSION: 310-0075-000; (79807)		EA	1							REF	REF		A8A7TB1E16H2
P--D		TERMINAL, STUD-GROUND: AB397-2, (12615)		EA	REF							REF	REF		A8A7TB1E17
P--D	5310-934-9740	NUT, PLAIN, HEXAGON: MS35649-225, (96906)		EA	1							REF	REF		A8A7TB1E17H1
P--D	5310-680-5557	WASHER, SPRING TENSION: 310-0075-000, (79807)		EA	1							REF	REF		A8A7TB1E17H2
P--D		TERMINAL, STUD-GROUND: AB397-2, (12615)		EA	REF							REF	REF		A8A7TB1E18
P--D	5310-934-9740	NUT, PLAIN, HEXAGON: W635649-225, (96906)		EA	1							REF	REF		A8A7TB1E8H1
P--D	5310-680-5557	WASHER, SPRING TENSION: 310-0075-000, (79807)		EA	1							REF	REF		A8A7TB1E18H2
P--D	5950-960-7338	TRANSFORMER, RADIO FREQUENCY: 553-9312-003, (13499)		EA	2						*	*		3-56	A8A7TB1T1
P--D	5310-934-9740	NUT, PLAIN, HEXAGON: MS35649-225; (96906)		EA	2							REF	REF		A8A7TB1T1H1

SECTION II

TM 11-5820-509-35

REPAIR PARTS FOR DIRECT SUPPORT, GENERAL SUPPORT, AND DEPOT MAINTENANCE (Continued)															
(1) SMR CODE	(2) FEDERAL STOCK NUMBER	(3) DESCRIPTION Reference Number & Mfr. Code Usable on Code		(4) UNIT OF MEAS	(5) QTY INC IN UNIT	(6) 30 DAY DS MAINTENANCE ALLOWANCE			(7) 30 DAY GS MAINTENANCE ALLOWANCE			(8) 1 YR ALW PER 100 EQUIP CNTGCTY	(9) DEPOT MAINT ALW PER 100 EQUIP	(10) ILLUSTRATION	
						(a) 1-20	(b) 21-50	(c) 51-100	(a) 1-20	(b) 21-50	(c) 51-100			(a) FIG NO.	(b) ITEM NO. OR REFERENCE DESIGNATION
P--D	5310-934-9740	NUT, PLAIN, HEXAGON: MS35649-225, (96906)		EA	REF							REF	REF		A8A7TB1IH2
P--D	5305-922-3506	SCREW, MACHINE: 330-2352-000, (70601)		EA	2							*	*		A8A7TB1H3
P--D		SCREW, MACHINE: 330-2352-000, (70601)		EA	REF							REF	REF		A8A7TB1T1H4
P--D		WASHER, NONMETALLIC, FLAT: 302-0050-000;(74921)		EA	2							*	*		A8A7TB1T1H5
P--D		WASHER, NONMETALLIC, FLAT: 302-0050-000, (74921)		EA	REF							REF	REF		A8A7TB1T1H6
P--D		WASHER, NONMETALLIC, FLAT: 303-1000-000, (79807)		EA	2							*	*		A8A7TB1T1H7
P--D		WASHER, NONMETALLIC, FLAT: 303-1000-000; ((9807)		EA	REF							REF	REF		A8A7TB1T1H8
P--D	5950-960-7338	TRANSFORMER, RADIO FREQUENCY: 553-9312-003; (13499)		EA	REF							REF	REF	3-56	A8A7TB1T3
P--D	5310-934-9740	NUT, PLAIN, HEXAGON: MS35649-225;(96906)		EA	2							REF	REF		A8A7B1T3H1
P--D	5310-934-9740	NUT, PLAIN, HEXAGON: MS35649-225; (96906)		EA	REF							REF	REF		A8A7TB1T3H2
P--D		SCREW, MACHINE: 330-2352-000; (70601)		EA	2							REF	REF		A8A7B1T3H3
P--D		SCREW, MACHINE; 330-2352-000; (70601)		EA	REF							REF	REF		A8A7TB1T3H4
P--D		WASHER, NONMETALLIC, FLAT: 302-0050-000;(74921)		EA	2							REF	REF		A8A7TB1T3H5
P--D		WASHER, NONMETALLIC, FLAT: 302-0050-000; (74921)		EA	REF							REF	REF		A8A7TB1T3H6
P--D		WASHER, NONMETALLIC, FLAT: 303-1000-000;(79807)		EA	2							REF	REF		A8A7TB1T3H7
P--D		WASHER, NONMETALLIC, FLAT: 303-1000-000;(79807)		EA	REF							REF	REF		A8A7TB1T3H8
P--D	5950-960-7339	TRANSFORMER, RADIO FREQUENCY: 553-9313-003, (13499)		EA	2								*	3-56	A8A7TB1T2
P--D	5950-960-7339	TRANSFORMER, RADIO FREQUENCY: 553-9313-003; (13499)		EA	REF							REF	REF	3-56	A8A7TB1T4
P--D	5961-787-5305	TRANSISTOR: 4JX11B2023; (03508)		EA	1							*	*	3-56	A87B1Q29
P--D	5961-836-0176	TRANSISTOR: 2N703, (07688)		EA	4							*	*	3-56	A8A7TB1Q24
P--D	5961-836-0376	TRANSISTOR: 2N703, (07688)		EA	REF							REF	REF	3-56	A8A7TB1Q25
P--D	5961-836-0376	TRANSISTOR: 2N703, (07688)		EA	REF							REF	REF	3-56	A8A7TB1Q26
P--D		5961-836-0376 TRANSISTOR: 2N703, (07688)		EA	REF							REF	REF	3-56	A8ATB1Q28
P--D	5961-842-6937	TRANSISTOR: JAN2N706, (81350)		EA	1							*	*	3-56	A8A7TB1Q27
P-H-T	5820-975-5419	MULTIPLIER, FREQUENCY: 549-5783-004, (13499)		EA	1				*	*	*	*	*	3-15	A8A7E5

SECTION II

TM 11-5820-509-35

REPAIR PARTS FOR DIRECT SUPPORT, GENERAL SUPPORT, AND DEPOT MAINTENANCE (Continued)															
(1) SMR CODE	(2) FEDERAL STOCK NUMBER	(3) DESCRIPTION Reference Number & Mfr. Code Usable on Code		(4) UNIT OF MEAS	(5) QTY INC IN UNIT	(6) 30 DAY DS MAINTENANCE ALLOWANCE			(7) 30 DAY GS MAINTENANCE ALLOWANCE			(8) 1 YR ALW PER 100 EQUIP CNTGCTY	(9) DEPOT MAINT ALW PER 100 EQUIP	(10) ILLUSTRATION	
						(a)	(b)	(c)	(a)	(b)	(c)			(a) FIG NO.	(b) ITEM NO. OR REFERENCE DESIGNATION
						1-20	21-50	51-100	1-20	21-50	51-100				
P--D		SCREW, MACHINE: MS51957-20, (96906)		EA	4							*	*		A8A7E5HL
P--D		D5310-245-880 WASHER: 310-6325-000; (79807)		EA	4							*	*		A8A7E5H4
P--D		WASHER, LOCK, SPRING: MS35338-135, (96906)		EA	4							REF	REF		A8A7ESH4
X1-D		BOARD, PRINTED CIRCUIT: 549-5785-004, (13499)		EA	1									13-58	A6A7E5E1
X1-D		SCREW, MACHINE: MS51957-14, (96906)		EA	4										A8A7E5E1Hi
X1-D		SCREW, MACHINE: MS51957-14, (96906)		EA	REF										A8A7E5E1H2
X1-D		SCREW, MACHINE: MS51957-14, (96906)		EA	REF										A8A7E5E1H3
X1D		SCREW, MACHINE: MS51957-14, (96906)		EA	REF										A8A7E5E1H4
X1-D		BRACKET, FREQUENCY MULTIPLIER: 549-5742-002, (13499)		EA	2										A8A7ESMP1
X1-D		BRACKET, FREQUENCY MIULTIPLIER: 549-5742-002, (1399)		EA	REF										A8A7E5MP2
X1-D		CAPACITOR, FIXED, MICA: CM05CD00D03, (81349)		EA	1									3-58	A8A7ESC71
X1-D		CAPACITOR, FIXED, MICA: CM05ED360J03, (81349)		EA	1									3-58	A8A7ESC91
X1-D		CAPACITOR, FIXED, MICA: CM05ED560J03; (81349)		EA	1									3-58	A8A7ESC89
X1-D		CAPACITOR, FIXED, MICA: CM05ED680J03, (81349)		EA	1									3-58	A8A7E5C87
X1-D		CAPACITOR, FIXED, MICA: CM05ED820J03, (81349)		EA	1									3-58	A8A7E5C85
X1-D		CAPACITOR, FIXED, MICA: CM0SFD131J03, (81349)		EA	1									3-58	ASA7ESC83
Y1-D		CAPACITOR, FIXED, MICA: CM0SFD131J03, (81349)		EA	1									3-58	A8A7E5C81
X1-D		CAPACITOR, FIXED, MICA: C',-D1i6co03, (131 9)		EA	1									3-58	A8A7E5C79
X1-D		CAPACITOR, FIXED, MICA: CM05FD201G03, (8-179)		EA	1									3-58	A8A7ESC77
X1-D		CAPACITOR, FIXED, MICA: CM05FD271G03, (813-9)		EA	1									358	A8A7ESC75
XI-D		CAPACITOR, FIXED, MICA: CM05FD361G03, (81349)		EA	1									3-58	A8A7E5C73
X1-D		CAPACITOR, VARIABLE, CERAMIC: 557-018-8-50E		EA	10									3-58	A8A7E5C72
X1-D		SCREW, MACHINE: MS51957-14, (96906)		EA	2										A8A7E5C72H1
X1-D		SCREW, MACHINE: MS51957-14; (96906)		EA	REF										A8A7E5C72F2
X1-D		CAPACITOR, VARIABLE, CERAMIC: 557-018-8-50E; (72982)		EA	REF									3-58	A8A7E5C74

SECTION II

TM 11-5820-509-35

REPAIR PARTS FOR DIRECT SUPPORT, GENERAL SUPPORT, AND DEPOT MAINTENANCE (Continued)															
(1) SMR CODE	(2) FEDERAL STOCK NUMBER	(3) DESCRIPTION Reference Number & Mfr. Code Usable on Code		(4) UNIT OF MEAS	(5) QTY INC IN UNIT	(6) 30 DAY DS MAINTENANCE ALLOWANCE			(7) 30 DAY GS MAINTENANCE ALLOWANCE			(8) 1 YR ALW PER 100 EQUIP CNTGCTY	(9) DEPOT MAINT ALW PER 100 EQUIP	(10) ILLUSTRATION	
						(a) 1-20	(b) 21-50	(c) 51-100	(a) 1-20	(b) 21-50	(c) 51-100			(a) FIG NO.	(b) ITEM NO. OR REFERENCE DESIGNATION
X1-D		SCREW, MACHINE: MS51957-14 (96906)		EA	2										A8A7E5C74H1
X1-D		SCREW, MACHINE: MS51957-14; (9690 6)		EA	REF										A8A7ESC74H2
X1-D		CAPACITOR, VARIABLE, CERAMIC: 557-018-8-50E.(72982)		EA	REF								3-58		A8A7ESC76
Y1-D		SCREW, MACHINE: MS51957-14, (96906)		EA	2										A8A7ESC76H1
X1-D		SCREW, MACHINE: MS51957-14, (96906)		EA	REF										A8A7LSC76H2
X1-D		CAPACITOR, VARIABLE CERAMIC: 557-018-8-50E, (72982)		EA	REF								3-58		A8A7E5C78
X1-D		SCREW, MACHINE: MS51957-14.(96906)		EA	2A										8A7E5C78H1
X1-D		SCREW, MACHINE: MS51957-14; (96906)		EA	REF										A3A7E5C78H2
X1-D		CAPACITOR, VARIABLE, CERAMIC: 557-018-8-50E, (72982)		EA	REF								3-58		A8A7E5C80
X1-D		SCREW, MACHINE: MS51957-14; (96906)		EA	2										A8A7ESC80H1
X1-D		SCREW, MACHINE: MS51957-14.(96906)		EA	REF										A8A7ESC80H2
X1-D		CAPACITOR, VARIABLE, CERAMIC: 557-018-8-50E; (72982)		EA	REF								3-58		A8A7E5C82
X1-D		SCREW, MACHINE: MS51957-14, (96906)		EA	2										A8A7E5C8-H1
X1-D		SCREW, MACHINE: MS51957-14, (96906)		EA	REF										A8A7E5C82H2
X1-D		CAPACITOR, VARIABLE, CERAMIC: 557-018-8-50 E (72982)		EA	REF								3-58		A8A7E5C84
X1-D		SCREW, MACHINE: MS51957-14; (96906)		EA	2										A8A7ESC84H1
X1-D		SCREW, MACHINE: MS51957-14, (96906)		EA	REF										A8A7E5C84H2
X1-D		CAPACITOR, VARIABLE, CERAMIC: 557-018-8-50E, (72982)		EA	REF								3-58		A8A7ESC86
X1-D		SCREW, MACHINE: S51957-14; (96906)		EA	2										A8A7ESC86H1
X1-D		SCREW, MACHINE: MS51957-14, (96906)		EA	REF										A8A7E5C86H2
X1-D		CAPACITOR, VARIABLE, CERAMIC: 557-0188-8-5E, (72982)		EA	REF								3-58		A8A7E5C88
X1-D		SCREW, MOCHINE: MS51957-14;(96906)		EA	2										A8A7ESC88H1
X1-D		SCREW, MACHIME: 1S51957-14, (96906)		EA	REF										A8A7E5C88H2
X1-D		CAPACITOR, VARIABLE, CERAMIC: 557-018-8-50E; (72982)		EA	REF								3-58		A8A7E5C90
X1-D		SCREW, MACHINE: MS51957-14, (96906)		EA	2										A8A7E5C90H1

SECTION II

TM 11-5820-509-35

REPAIR PARTS FOR DIRECT SUPPORT, GENERAL SUPPORT, AND DEPOT MAINTENANCE (Continued)															
(1) SMR CODE	(2) FEDERAL STOCK NUMBER	(3) DESCRIPTION Reference Number & Mfr. Code Usable on Code		(4) UNIT OF MEAS	(5) QTY INC IN UNIT	(6) 30 DAY DS MAINTENANCE ALLOWANCE			(7) 30 DAY GS MAINTENANCE ALLOWANCE			(8) 1 YR ALW PER 100 EQUIP CNTGCTY	(9) DEPOT MAINT ALW PER 100 EQUIP	(10) ILLUSTRATION	
						(a) 1-20	(b) 21-50	(c) 51-100	(a) 1-20	(b) 21-50	(c) 51-100			(a) FIG NO.	(b) ITEM NO. OR REFERENCE DESIGNATION
X1-D		SCREW, MACHINE: MS51957-14, (96906)		EA	REF										A8A7ESC90H2
X1-D		CLAP, CABLE: 549-56L 3-002, (13499)		EA	1										A8A7E5MP3
X1-D		SCREW, MACHINE: P34L3-02P7-000, (77250)		EA	1										A8A7E5SP3H1
X1-D		COIL, RADIO FREQUENCY: 549-574R-002 (13499)		EA	1								3-58		A8A7ESL19
X1-D		CONTACT, ELECTRICAL-NO1: 5L9-5746-002 (13499)		EA	2										A8A7ESE2
X1-D		NUT, SELF-LOCKING, HEXAGON: 65-1660-26; (72962)		EA	4										A8A7E5E2H1
X1-D		NUT, SELF-LOCKING, HEXAGON: 68-1660-26, (72962)		EA	REF										A8A7E5E2H2
X1-D		NUT, SELF-LOCKING, HEXAGON: 68-1660-26, (72962)		EA	REF										A8A7E5E2H3
X1-D		NUT, SELF-LOCKING, HEXAGON: 68-1660-26, (72962)		EA	REF										A8A7E5E2H4
X1-D		SCREW, MACHINE: MS51957-4, (96906)		EA	4										A8A7E5E2H5
X1-D		SCREW, MACHINE: MS51957-4, (96906)		EA	REF										A8A7ESE2H6
X1-D		SCREW, MACHINE: MS51957-4, (96906)		EA	REF										A8A7ESE2H7
X1-D		SCREW, MACHINE: MS51957-L, (96906)		EA	REF										A8A7E5E2H8
X1-D		CONTACT, ELECTRICAL-NO1: 549-57L6-002, (13499)		EA	REF										A8A7E5E3
X1-D		PETAINER, SWITCH 549-5744-002, (13499)		EA	2										A8A7ES4P4
X1-D		RETAINER, SWITCH: 549-5744-002, (13499)		EA	REF										A8A7E5KP5
X1-D		ROTOR, ELECTRICAL SWITCH: 549-5743-002, (13499)		EA	1										A8A7E5E4
X1-D		SLEEVE, SPACING: 756-7602-002, (13499)		EA	1										A8A7E54P6
M-D		PLATE, BASE, CONTROL: 5L9-5755-003, (13499)		EA	1										A8A7MP9
P--D		SCREW, SELF-LOCKING: LP51959-13M, (03038)		EA	1							REF	REF		A8A7MP9K1
P--D		SCREW, SELF-LOCKING: LP51959-13M, (0303e)		EA	REF							REF	REF		A8A74P9H2
P--D		SCREW, SELF-LOCKING: LP51959-13M, (03038)		EA	REF							REF	REF		A8A774P9H3
P--D		SCREW, SELF-LOCKING: LP51959-13M, (03038)		EA	PEF							REF	REF		A8AMiP9H4
P--D		SCREW, SELF-LOCKING: LP51959-13M; (03038)		EA	REF							REF	REF		A8A714P9H5
P--D		SCREW, SELF-LOCKING: LP51959-13M, (03038)		EA	REF							REF	REF		A8A7MP9H6

SECTION II

TM 11-5820-509-35

REPAIR PARTS FOR DIRECT SUPPORT, GENERAL SUPPORT, AND DEPOT MAINTENANCE (Continued)															
(1) SMR CODE	(2) FEDERAL STOCK NUMBER	(3) DESCRIPTION Reference Number & Mfr. Code Usable on Code		(4) UNIT OF MEAS	(5) QTY INC IN UNIT	(6) 30 DAY DS MAINTENANCE ALLOWANCE			(7) 30 DAY GS MAINTENANCE ALLOWANCE			(8) 1 YR ALW PER 100 EQUIP CNTGCTY	(9) DEPOT MAINT ALW PER 100 EQUIP	(10) ILLUSTRATION	
						(a) 1-20	(b) 21-50	(c) 51-100	(a) 1-20	(b) 21-50	(c) 51-100			(a) FIG NO.	(b) ITEM NO. OR REFERENCE DESIGNATION
P--D		SCREW, SELF-LOCKING LP51959-13M; (03038)		EA	REF							REF	REF	A8A7MP9H7	
P--D		SCREW, SELF-LOCKING: LP51959-13M; (03038)		EA	REF							REF	REF	A8A714P9H8	
P--D		SCREW, SELF-LOCKING: LP51959-13M; (03038)		EA	REF							REF	REF	A8A7MP9H9	
P--D		SCREW, SELF-LOCKING: LP51959-13M; (03038)		EA	REF							REF	REF	ABA7MP9H10	
P--D		SCREW, SELF-LOCKING: LP51959-13M; (03038)		EA	REF							REF	REF	A8A7MP9H11	
P--D		SCREW, SELF-LOCKING: LP51959-13M; (03038)		EA	REF							REF	REF	A8A7MP9H12	
P--D		SCREW, SELF-LOCKING: LP51959-13M; (03038)		EA	REF							REF	REF	A8A7MP9H13	
P--D		SCREW, SELF-LOCKING: LP51959-13M; (03038)		EA	REF							REF	REF	A8A7MP9H14	
M--D		PLATE, CHASSIS-FRONT: 549-5711-002; (13499)		EA	1									A8A7MP10	
P--D		SCREW, SELF-LOCKING: LP51959-13M; (03038)		EA	6							REF	REF	A8A7MP10H1	
P--D		SCREW, SELF-LOCKING: LP51959-13M; (03038)		EA	REF							REF	REF	ABATM4P10H2	
P--D		SCREW, SELP-LOCKING: LP51959-13M; (03038)		EA	REF							REF	REF	A8A7MP10H3	
P--D		SCREW, SELF-LOCKING: LP51959-139; (03038)		EA	REF							REF	REF	A8A77P10H4	
P--D		SCREW, SELF-LOCKING: LP51959-13M; (03038)		EA	REF							REF	REF	A8A7MP10H5	
P--D		SCREW, SELF-LOCKING: LP51959-13M; (03038)		EA	REF							REF	REF	A8A7TP10H6	
P--D		PLATE, CHASSIS-REAR: 549-5775-004, (13499)		EA	1									A8A7MP11	
P--D		SCREW, SELF-LOCKING: LP51959-13M; (03038)		EA	6							REF	REF	A8A7MP11H1	
P--D		SCREW, SELF-LOCKING: LP51959-13M; (03038)		EA	REF							REF	REF	A8A7AP11H2	
P--D		SCREW, SELF-LOCKING: LP51959-13M; (03038)		EA	REF							REF	REF	A8A7TP11H3	
P--D		SCREW, SELF-LOCKING: LP51959-13M; (03038)		EA	REF							REF	REF	A8A7TP11H1H	
P--D		SCREW, SELF-LOCKING: LP51959-13M; (03038)		EA	REF							REF	REF	A8A7MP11H5	
P--D		SCREW, SELF-LOCKING: LP51959-13M; (03038)		EA	REF							REF	REF	A8A74P11H6	
M--D		PLATE, ELECTRICAL SHIELD 569-5767-003; (13499)		EA	1									ARATMP12	
P--D	5305-770-2533	SCREW, MACHINE: MS51959-13; (96906)		EA	4						REF	REF		A8A7MP12H1	
P--D	5305-770-2533	SCREW, MACHINE: MS51959-13; (96906)		EA	REF							REF	REF	A8A7M4P12H2	

SECTION II

TM 11-5820-509-35

REPAIR PARTS FOR DIRECT SUPPORT, GENERAL SUPPORT, AND DEPOT MAINTENANCE (Continued)															
(1) SMR CODE	(2) FEDERAL STOCK NUMBER	(3) DESCRIPTION Reference Number & Mfr. Code Usable on Code		(4) UNIT OF MEAS	(5) QTY INC IN UNIT	(6) 30 DAY DS MAINTENANCE ALLOWANCE			(7) 30 DAY GS MAINTENANCE ALLOWANCE			(8) 1 YR ALW PER 100 EQUIP CNTGCTY	(9) DEPOT MAINT ALW PER 100 EQUIP	(10) ILLUSTRATION	
						(a) 1-20	(b) 21-50	(c) 51-100	(a) 1-20	(b) 21-50	(c) 51-100			(a) FIG NO.	(b) ITEM NO. OR REFERENCE DESIGNATION
P--D	5305-770-2533	SCREW, MACHINE: MS51959-13, (96906)		EA	REF							REF	REF		A8A7MP12H3
P--D	5305-770-2533	SCREW MACHINE: MS51959-13, (96906)		EA	REF							REF	REF		A7AMP12H4
M--D		PLATE, RETAINING, BEARING: 549-5710-002, (13b99)		EA	2										A8A7MP13
P--D	5305-054-5636	SCREW, MACHINE: MS51957-2, (96906)		EA	3							*	*		A8A7MP13H1
P--D	5305-054-5636	SCREW, MACHINE: MS51957-2, (96906)		EA	REF							REF	REF		A8A7MP13H2
P--D	5305-054-5636	SCREW, MACHINE: MS51957-2, (96906)		EA	REF							REF	REF		A8A7MP13H3
P--D	5310-928-2690	WASHER, LOCK, SPRING: WM35338-134, (96906)		EA	3							*	*		A8A7MP13H4
P--D	5310-928-2690	WASHER, LOCK, SPRING: MS35338-134, (96906)		EA	REF							REF	REF		A8A7MP13HS
P--D	5310-928-2690	WASHER, LOCK, SPRING: MS35338-134, (96906)		EA	REF							REF	REF		A8A7MP13H6
M--D		PLATE, RETAINING, BEARING: 549-5710-002; /13499)		EA	REF										A8A7MP14
P--D	5305-054-5636	SCREW, MACHINE: MS51957-2, (96906)		EA	3							REF	REF		A8A7MP1LH1
P--D	5305-054-5636	SCREW, MACHINE: MS51957-2; (96906)		EA	REF							REF	REF		A8A7MP14H2
P--D	5305-054-5636	SCREW, MACHINE: MS51957-2, (96906)		EA	REF							REF	REF		A8A7MP14H3
P--D	5310-928-2690	WASHER, LOCK, SPRING: MS35338-134, (96906)		EA	3							REF	REF		A8A7MP1LHL
P--D	5310-928-2690	WASHER, LOCK, SPRING: MS35338-13L; (96906)		EA	REF							REF	REF		A8A7MP14H5
P--D	5310-928-2690	WASHER, LOCK, SPRING: MS35338-134, (96906)		EA	REF							REF	REF		A8A7MP14H6
P--D	5340-663-1245	RING, RETAINING: MS16632-1031, (96906)		EA	2							*	*		A8A7H1
P--D	5310-663-1245	RING, RETAINING MS16632-1031, (96906)		EA	REF							REF	REF		ASA7H2
M--D	5820-975-7645	SHAFT, SWITCH NO1: 5L9-5717-002, (13499)		EA	1										A8A7A2
M--D		COUPLING, SHAFT, FLEXIBLE: 549-5719-002, (13L99)		EA	1										A8A7A2A1
M--D		COUPLING, HALF, SHAFT: 5h49-5760-003, (13499)		EA	1										ASA7A2A1MP1
M--D		INSERT, FLEXIBLE COUPLING: 549-5720-002, (13499)		EA	1										A8A7A2A1MP2
M--D		PIN, SHOULDER, HEADED: 549-5721-002, (13499)		EA	1										A8A7A2A1MP3
M--D	5315-058-9698	PIN, SPRING, TUBULAR SLOTTED: MS16562-191, (96906)		EA	1										A8A7A2MP1
M--D		SHAFT, SHOULDERED NO1: 549-5718-002, (13499)		EA	1										A8A7A2MP2

REPAIR PARTS FOR DIRECT SUPPORT, GENERAL SUPPORT, AND DEPOT MAINTENANCE (Continued)

(1) SMR CODE	(2) FEDERAL STOCK NUMBER	(3) DESCRIPTION Reference Number & Mfr. Code Usable on Code		(4) UNIT OF MEAS	(5) QTY INC IN UNIT	(6) 30 DAY DS MAINTENANCE ALLOWANCE			(7) 30 DAY GS MAINTENANCE ALLOWANCE			(8) 1 YR ALW PER 100 EQUIP CNTGCTY	(9) DEPOT MAINT ALW PER 100 EQUIP	(10) ILLUSTRATION	
						(a) 1-20	(b) 21-50	(c) 51-100	(a) 1-20	(b) 21-50	(c) 51-100			(a) FIG NO.	(b) ITEM NO. OR REFERENCE DESIGNATION
						M--D	5820-975-7646	SHAFT, SWITCH-NO.2: 549-5722-002, (13499)	EA	1					
M--D		COUPLING, SHAFT, FLEXIBLE: 549-5719-002, (13499)	EA	1											ABA7A3A1
M--D		COUPLING, HALF, SHAFT: 549-5760-003, (13499)	EA	1											A8A7A3A1MP1
M--D		INSERT, FLEXIBLE COUPLING: 549-5720-002, (13499)	EA	1											A8A7A3A1MP2
M--D		PIN, SHOULDER, HEADED: 549-5721-002, (13499)	EA	1											A8A7A3A1MP3
M--D	5315-058-9698	PIN, SPRING, TUBULAR SLOTTED: MS16562-191, (96906)	EA	1											A8A7A3MP1
M--D		SHAFT, SHOULDERED NO.2: 549-5723-002; (13499)	EA	1											A8A7A3MP2
M--D		SPACER, SLEEVE: 541-5987-002, (13499)	EA	REF											A8A7MP15
M--D		SPACER, SLEEVE: 541-5987-002; (13499)	EA	REF											A8A7MP16
M--D		SPACER, SLEEVE: 541-5987-002; (13499)	EA	REF											A8A7MP17
M--D		SPACER, SLEEVE: 541-5987-002, (13499)	EA	REF											A8A7MP18
P--D	5340-975-7037	POST, ELECTRICAL, MECHANICAL: 549-5709-002, (13499)	EA	1							*	*			A8A7E8
P--D	5940-259-8457	TERMINAL, STUD: RTmT12M, (91663)	EA	1							*	*			A8A7E9
P-F-S		AMPLIFIER, MODULATOR: AN350TPRC47, (80058)	EA	1	*	*	*	*	*	*	*	*	3-4		A8A2
P-H-T	5820-975-5427	AMPLIFIER, MIXER SUBASSIBLY-IF: 549-5691-003; (13499)	EA	1				*	*	*	*	*	3-21		A8A2E3
P--D		SCREW, SELF-LOCKING: MAS1190C04P3; (80205)	EA	3							*	*			A8A2E3H3
X1-D		BOARD, PRINTED CIRCUIT, NO.3: 549-5682-003, (13499)	EA	1									3-21		A8A2E3E1
X1-D		CAPACITOR, FIXED, CERAMIC: CK60AWn02n; (813;9)	EA	1									3-21		A8A2E3C30
X1-D		CAPACITOR, FIXED, CERAMIC: 6S8084, (56289)	EA	1									3-21		A8A2E3C31
X1-D		CAPACITOR, FIXED, ELECTROLYTIC: 150D104X0035A2; (56289)	EA	1									3-21		A8A2E3C25
X1-D		CAPACITOR, FIXED, ELECTROLYTIC: 150D685X00035B2, (56289)	EA	1									3-21		A8A2E3C13
X1-D		CAPACITOR, FIXED, MICA: CM05FDIOGC3, (81349)	EA	1									3-21		A8A2E3CII
X1-D		CAPACITOR, FIXED, MICA: CM05DFD21J03, (81349)	EA	1									3-21		A8A2E3C12
X1-D		CAPACITOR, FIXED, MICA: CM05FD391C03, (81349)	EA	1									3-21		A8A2E3C11
X1-D		CAPACITOR, FIXED, MICA: DM15F511J300VV4CR, (72135)	EA	2									3-21		A8A2E3C28

SECTION II

TM 11-5820-509-35

REPAIR PARTS FOR DIRECT SUPPORT, GENERAL SUPPORT, AND DEPOT MAINTENANCE (Continued)															
(1) SMR CODE	(2) FEDERAL STOCK NUMBER	(3) DESCRIPTION Reference Number & Mfr. Code Usable on Code		(4) UNIT OF MEAS	(5) QTY INC IN UNIT	(6) 30 DAY DS MAINTENANCE ALLOWANCE			(7) 30 DAY GS MAINTENANCE ALLOWANCE			(8) 1 YR ALW PER 100 EQUIP CNTGCTY	(9) DEPOT MAINT ALW PER 100 EQUIP	(10) ILLUSTRATION	
						(a)	(b)	(c)	(a)	(b)	(c)			(a) FIG NO.	(b) ITEM NO. OR REFERENCE DESIGNATION
						1-20	21-50	51-100	1-20	21-50	51-100				
X1-D		CAPACITOR, FIXED, MICA: DM15F511J300WV4CR; (72136)		EA	REF									3-21	A8A2E3C29
X1-D		CAPACITOR, VARIABLE, CERAMIC: 557-099-8-50E; (72982)		EA	1									3-21	A8A2E3C15
X1-D		COIL, RADIO FREQUENCY: LT10K043; (81349)		EA	1									3-21	A8A2E3L8
X1-D		RESISTOR, FIXED, COOMPOSITION: RCR07G561KS; (81349)		EA	2									3-21	A8A2E3R36
X1-D		RESISTOR, FIXED, COMPOSITION: RCR07G561KS; (81349)		EA	REF									3-21	A8A2E3R37
X1-D		RESISTOR, FIXED, COMPOSITION: RCR07C222KS; (81349)		EA	2									3-21	A8A2E3R20
X1-D		RESISTOR, FIXED, COMPOSITION: RCR07G222KS; (81349)		EA	REF									3-21	A8A2E3R21
X1-D		RESISTOR, FIXED, COMPOSITION: RCRD7G562KS; (81349)		EA	1									3-21	A8A2E3R38
X1-D		RESISTOR, FIXED, COMPOSITION: RCR07GC103KS; (81349)		EA	1									3-21	A8A2E3R24
X1-D		RESISTOR, FIXED, COMPOSITION: RCR07G183KS; (81349)		EA	1									3-21	A8A2E3R22
X1-D		SEMICONDUCTOR DEVICE, DIODE: 1N198; (07688)		EA	2									3-21	A8A2E3CR7
X1-D		SEMICONDUCTOR DEVICE, DIODE: 1N198; (07688)		EA	REF									3-21	A8A2E3CR8
X1-D		TRANSISTOR: 2N274, (07688)		EA	1									3-21	A8A2E3Q2
P-H-T	5880-975-5428	AMPLIFIER SURASSEMBLY IF BOARD: 549-5692-004; (13499)		EA	1				*	*	*	*	*	3-21	A8A2E4
P--D		SCREW, SELF-LOCKING: NAS1090C4P3; (80205)		EA	3							*	*		AA2E4H3
X1-D		BOARD, PRINTED CIRCUIT-NO.4: 549-5684-003; (13499)		EA	1									3-21	A8A2E4E1
X1-D		CAPACITOR, FIXED, ELECTROLYTIC: 150D156X0020B2; (56289)		EA	1									3-21	A8A2E4C18
X1-D		CAPACITOR, FIXED, ELECTROLYTIC: 150D104X0035A2; (56289)		EA	2									3-21	A8A2E4C19
X1-D		CAPACITOR, FIXED, ELECTROLYTIC: 150D01X0035A2; (56289)		EA	REF									3-21	A8A2E4C20
X1-D		CAPACITOR, FIXED, ELECTROLYTIC: 150D0105X935A2; (56289)		EA	1									3-21	A8A2E4C23
X1-D		CAPACITOR, FIXED, MICA: CMD5FD910G03; (81349)		EA	1									3-21	A8A2E4C16
X1-D		CAPACITOR, FIXED, MICA: CMD05FD221J03; (81349)		EA	1									3-21	A8A2E4C22
X1-D		CAPACITOR, FIXED, MICA: DM15F511J300WV4CR; (72136)		EA	1									3-21	A8A2E4C21
X1-D		CAPACITOR, VARIABLE, CERAMIC: 557-099-8-50E; (72982)		EA	1									3-21	A8A2E4C17
X1-D		COIL, RADIO FREQUENCY: LT10K043; (81349)		EA	1									3-21	A8A2E4L5

SECTION II

TM 11-5820-509-35

REPAIR PARTS FOR DIRECT SUPPORT, GENERAL SUPPORT, AND DEPOT MAINTENANCE (Continued)															
(1) SMR CODE	(2) FEDERAL STOCK NUMBER	(3) DESCRIPTION Reference Number & Mfr. Code Usable on Code		(4) UNIT OF MEAS	(5) QTY INC IN UNIT	(6) 30 DAY DS MAINTENANCE ALLOWANCE			(7) 30 DAY GS MAINTENANCE ALLOWANCE			(8) 1 YR ALW PER 100 EQUIP CNTGCTY	(9) DEPOT MAINT ALW PER 100 EQUIP	(10) ILLUSTRATION	
						(a) 1-20	(b) 21-50	(c) 51-100	(a) 1-20	(b) 21-50	(c) 51-100			(a) FIG NO.	(b) ITEM NO. OR REFERENCE DESIGNATION
X1-D		RESISTOR, FIXED, COMPOSITION: RCR07G102KS; (81349)		EA	1									321	ASA2E4R23
X1-D		RESISTOR, FIXED, COMPOSITION: RCR07C222KS; (81349)		EA	2									3-21	A8A2E4R26
X1-D		RESISTOR, FIXED, COMPOSITION: RCR07G222KS; (81349)		EA	REF									3-21	A8A2E4R30
X1-D		RESISTOR, FIXED, COMPOSITION: RCR07G272KS; (81349)		EA	1									3-21	A8A2E4R25
X1-D		RESISTOR, FIXED, COMPOSITION: RCR07G562KS; (81349)		EA	1									3-21	A8A2E4R29
X1-D		RESISTOR, FIXED, COMPOSITION: RCR07G103KS; (81349)		EA	2									3-21	A8A2E4R31
X1-D		RESISTOR, FIXED, COMPOSITION: RCR07CG103KS; (81349)		EA	REF									3-21	A8A2E4R39
X1-D		RESISTOR, FIXED, COMPOSITION: RCR07TG273KS; (81349)		EA	1									3-21	A8A2E4R32
X1-D		RESISTOR, FIXED, COMPOSITION: RCR07C683KS; (81349)		EA	1									3-21	A8A2E4R28
X1-D		TRANSISTOR: 2N274; (07688)		EA	2									3-21	A8A2E4Q3
X1-D		TRANSISTOR: 21274; (07688)		EA	REF									3-21	A8A2E4Q4
P-H-T	5820-975-429	AMPLIFIER SUBASSEMBLY, IF BOARD: 549-5693-004; (13499)		EA	1				*	*	*	*	*	3-21	A8A2E5
P--D		SCREW, SELF-LOCKING: NAS119CO4P3; (80205)		EA	2							REF	REF	3-21	A8A2E5H2
X1-D		BOARD, PRINTED CIRCUIT-NO.5: 519-5686-003; (13499)		EA	1										A8A2E5E1
X1-D		CAPACITOR, FIXED, CERAMIC: 658084; (56289)		EA	1									3-21	A8A2E5C26
X1-D		CAPACITOR, FIXED, MICA: CM05FD21J03; (81349)		EA	2									3-21	A8A2E5C27
X1-D		CAPACITOR, FIXED, MICA: CM05FD221J03; (81349)		EA	REF									321	A8A2E5C32
X1-D		CAPACITOR, FIXED, MICA: CM05FD391GC3; (81349)		EA	1									3-21	A8A2E5C24
X1-D		COIL, RADIO FREQUENCY: X419-1; (81815)		EA	2									3-21	A8A2E5L6
X1-D		COIL, RADIO FREQUENCY: X419-1; (81815)		EA	REF									3-21	A8A2E5L7
X1-D		RELAY, ARMATURE: 3100L037-1001; (80294)		EA	1									321	A8A2E5K1
X1-D		RESISTOR, FIXED, COMPOSITION: RCR07CG390KS; (81349)		EA	1									3-21	A8A2E5R40
X1-D		RESISTOR, FIXED, COMPOSITION: RCR07G152KS; (81349)		EA	1									3-21	A8A2E5R33
X1-D		RESISTOR, FIXED, COMPOSITION: RCR07C273KS; (81349)		EA	1									3-21	A8A2E5R34
X1-D		RESISTOR, FIXED, COMPOSITION: RCR07G683KS; (81349)		EA	1									3-21	A8A2E5R35

SECTION II

TM 11-5820-509-35

REPAIR PARTS FOR DIRECT SUPPORT, GENERAL SUPPORT, AND DEPOT MAINTENANCE (Continued)															
(1) SMR CODE	(2) FEDERAL STOCK NUMBER	(3) DESCRIPTION Reference Number & Mfr. Code Usable on Code		(4) UNIT OF MEAS	(5) QTY INC IN UNIT	(6) 30 DAY DS MAINTENANCE ALLOWANCE			(7) 30 DAY GS MAINTENANCE ALLOWANCE			(8) 1 YR ALW PER 100 EQUIP CNTGCTY	(9) DEPOT MAINT ALW PER 100 EQUIP	(10) ILLUSTRATION	
						(a) 1-20	(b) 21-50	(c) 51-100	(a) 1-20	(b) 21-50	(c) 51-100			(a) FIG NO.	(b) ITEM NO. OR REFERENCE DESIGNATION
X1-D		TRANSISTOR: 2N274; (07688)		EA	1									3-21	A8A2E5Q5
X1-D		TRANSFORMER, INTERMEDIATE FREQUENCY X418-1; (31815)		EA	1									3-21	A8A2E5Q3
P--D		CAPACITOR, FIXED, CERAMIC: CK13BX103; (81349)		EA	1							REF	REF	3-21	A6A2C33
P--D	5910-663-7276	CAPACITOR, FIXED, ELECTROLYTIC: 150DL7LX0035A2; (56289)		EA	1							*	*	3-20	A8A2C37
P--D	5999-165-3692	CHASSIS, ELECTRICAL EQUIPMENT: 549-6404-004; (13499)		EA	1							*	*	3-20	A8A2A1
Xi-D		JACK, TIP: 72-153BRN; (12615)		EA	1									3-21	A8A2A1J1
X1-D		JACK, TIP: 72-153RED; (12615)		EA	1									3-20	A8A2A1J2
X1-D		JACK, TIP: 72-153ORN; (12615)		EA	1									3-21	A8A2A1J3
X1-D		JACK, TIP: 72-153YEL; (12615)		EA	1									3-21	A8A2A1J4
P--D	5950-070-7642	COIL, RADIO FREQUENCY: LT10K053; (813L9)		EA	1							REF	REF	3-21	A8A2L110
P--D	5950-070-7644	COIL, RADIO FREQUENCY: LT10K060; (81349)		EA	1							*	*	3-21	A8A2L9
P--D	5935-810-6598	CONNECTOR, RECEPTACLE: DAM7W2P; (71468)		EA	1							REF	REF	3-21	A8A2P1
P--D	5310-622-1724	NUT, SELF-LOCKING: 68-1660-26; (72962)		EA	2							PEF	REF		A8A2P3H1
P--D	5310-622-1724	NUT, SELF-LOCKING: 68-1660-26; (72962)		EA	REF							REF	REF		A8A2P3H2
P--D		SCREW, MACHINE: MS51959-3; (96906)		EA	2							*	*		A8A2P3H3
P--D		SCREW, MACHINE: MS51959-3; (96906)		EA	REF							REF	REF		A8A2P3H4
P--D	5310-167-0797	WASHER, FLAT: 310-0044-000; (79807)		EA	2							*	*		A8A2P3H5
P--D	5310-167-0797	WASHER, FLAT: 310-0444-000; (79807)		EA	REF							REF	REF		A8A2P3H6
P--D	5935-811-1382	CONNECTOR, RECEPTACLE: DBM13W3P; (71468)		EA	1							*	*	3-21	A8A2P4
P--D	5310-622-1724	NUT, SELF-LOCKING: 68-1660-26; (72962)		EA	2							REF	REF		A8A2P4H1
P--D	5310-622-1724	NUT, SELF-LOCKING: 68-1660-26; (72962)		EA	REF							REF	REF		A8A2P4H2
P--D	5305-764-2964	SCREW, MACHINE: KS51959-4; (96906)		EA	2							*	*		A8A2P4H3
P--D	5305-764-2964	SCREW, MACHINE: MS51959-4; (96906)		EA	REF							REF	REF		A8A2P4H4
P--D	5310-167-0797	WASHER, FLAT: 310-0044-000; (79807)		EA	2							REF	REF		A8A2P4H5
P--D	5310-167-0797	WASHER, FLAT: 310-0044-000; (79807)		EA	REF							REF	REF		A8A2P4H6

SECTION II

TM 11-5820-509-35

REPAIR PARTS FOR DIRECT SUPPORT, GENERAL SUPPORT, AND DEPOT MAINTENANCE (Continued)															
(1) SMR CODE	(2) FEDERAL STOCK NUMBER	(3) DESCRIPTION Reference Number & Mfr. Code Usable on Code		(4) UNIT OF MEAS	(5) QTY INC IN UNIT	(6) 30 DAY DS MAINTENANCE ALLOWANCE			(7) 30 DAY GS MAINTENANCE ALLOWANCE			(8) 1 YR ALW PER 100 EQUIP CNTGCTY	(9) DEPOT MAINT ALW PER 100 EQUIP	(10) ILLUSTRATION	
						(a) 1-20	(b) 21-50	(c) 51-100	(a) 1-20	(b) 21-50	(c) 51-100			(a) FIG NO.	(b) ITEM NO. OR REFERENCE DESIGNATION
P--D	5935-885-6505	CONTACT, ELECTRICAL: DM53740-5000; (71468)		EA	3							REF	REF		A8A2P3A1
P--D	5935-885-6505	CONTACT, ELECTRICAL: DM53740-5000; (71468)		EA	REF							REF	REF		A8A2P4A1
P--D	5935-885-6505	CONTACT, ELECTRICAL: DM53740-5000; (71468)		EA	REF							REF	REF		A8A2P4A2
P--D	5935-885-6508	CONTACT, ELECTRICAL: DM53741-5002; (71468)		EA	1							*	*		A8A2P4A3
P-H-T	5820-088-2515	CONTROL, AMPLIFIER, BOARD NO.2: 549-5678-003, (13499)		EA	1				*	*	*	*	*	3-20	A8A2E2
P--D		SCREW, SELF-LOCKING: NAS190C04P3; (80205)		EA	2							REF	REF	3-20	A8A2E2H2
X1-D		BOARD, PRINTED CIRCUIT-NO.2: 549-5680-003; (13499)		EA	1									3-20	A8A2E2E1
X1-D		CAPACITOR, FIXED, CERAMIC: SSM-1-77; (86335)		EA	1									3-20	A8A2E2C10
X1-D		CAPACITOR, FIXED, ELECTROLYTIC: 29F461; (06001)		EA	1									3-20	A8A2E2C3
X1-D		CAPACITOR, FIXED, ELECTROLYTIC: CL23BE400UNE; (81349)		EA	1									3-20	A8A2E2C5
X1-D		COIL, RADIO FREQUENCY: X419-1; (81815)		EA	1									3-20	A8A2E2L4
X1-D		RESISTOR, FIXED, COMPOSITION: RCR07G470KS; (81349)		EA	1									3-20	A8A2E2R13
X1-D		RESISTOR, AIXED, COMPOSITION: RCR07G152KS; (81349)		EA	1									3-20	A8A2E2R17
X1-D		RESISTOR, FIXED, COMPOSITION: RCR07G182KS; (81349)		EA	1									3-20	A8A2E2R14*
X1-D		RESISTOR, FIXED, COMPOSITION: RCR07G222KS; (81349)		EA	2									3-20	A8A2E2R14*
X1-D		RESISTOR, FIXED, COMPOSITION: RCR07G222KS; (81349)		EA	REF									3-20	A8A2E2R15
XI-D		RESISTOR, FIXED, COMPOSITION: RCR07G272KS; (81349)		EA	1									3-20	A8A2E2R14*
X1-D		RESISTOR, FIXED, COMPOSITION: RCR07G332KS; (81349)		EA	1									3-20	A8A2E2R11*
X1-D		RESISTOR, FIXED, COMPOSITION: RCR07G392KS; (81349)		EA	1									3-20	A8A2E2R14*
X1-D		RESISTOR, FIXED, COMPOSITION: RCR07GC72KS; (81349)		EA	1									3-20	A8A2E2R14*
X1-D		RESISTOR, FIXED, COMPOSITION: RCR07G562KS; (81349)		EA	1									3-20	A8A2E2R14*
X1-D		RESISTOR, FIXED, COMPOSITION: RCR07G682KS; (81349)		EA	1									3-20	A8A2E2R14*
X1-D		RESISTOR, FIXED, COMPOSITION: RCR07G822KS; (81349)		EA	1									3-20	A8A2E2R14*
X1-D		RESISTOR, FIXED, COMPOSITION: RCR07G103KS; (81349)		EA	1									3-20	A8A2E2R14*
X1-D		RESISTOR, FIXED, COMPOSITION RCR07GC153KS; (81349) *SELECT RER OPERATIONAL REQUIREMENT.		EA	1									3-20	A8A2E2R16

SECTION II

TM 11-5820-509-35

REPAIR PARTS FOR DIRECT SUPPORT, GENERAL SUPPORT, AND DEPOT MAINTENANCE (Continued)															
(1) SMR CODE	(2) FEDERAL STOCK NUMBER	(3) DESCRIPTION Reference Number & Mfr. Code Usable on Code		(4) UNIT OF MEAS	(5) QTY INC IN UNIT	(6) 30 DAY DS MAINTENANCE ALLOWANCE			(7) 30 DAY GS MAINTENANCE ALLOWANCE			(8) 1 YR ALW PER 100 EQUIP CNTGCTY	(9) DEPOT MAINT ALW PER 100 EQUIP	(10) ILLUSTRATION	
						(a) 1-20	(b) 21-50	(c) 51-100	(a) 1-20	(b) 21-50	(c) 51-100			(a) FIG NO.	(b) ITEM NO. OR REFERENCE DESIGNATION
						X1-D		RESISTOR, FIXED, COMPOSITION: RCR07GL73KS; (813L9)	EA	1					
X1-D		RESISTOR, FIXED, COMPOSITION: RCR20G473KS; (81349)	EA	1										3-20	A8A2E2R18
X1-D		RESISTOR, THERMAL: 763H10; (10646)	EA	1										3-20	A8A2E2R17
X1-D		TRANSFORMER, INTERMEDIATE FREQUEDCY X377-1; (81815)	EA	1										3-20	A8A2E2T2
X1-D		TRANSISTOR: 2N440; (07688)	EA	1										3-20	A8A2E2QI
M--D		COVER, CHASSIS-FRODT: 549-6412-003; (13499)	EA	1											A8A2MP1
P--D		SCREW, SELF-LOCKING: LP51959-13M; (03038)	EA	4								REF	REF		A8A2MP1H1
P--D		SCREW, SELF-LOCKING: LP51959-13M; (03038)	EA	REF								REF	REF		A8A2MP1H2
P--D		SCREW, SELF-LOCKING: LP51959-13M; (03038)	EA	REF								REF	REF		A8A2MP1H3
P--D		SCREW, SELF-LOCKING: LP51959-13M, (03038)	EA	REF								REF	REF		A8A2MP1H4
M--D		COVER, CHASSIS-REAR: 549-6411-003, (13499)	EA	1											A8A2MP2
P--D		SCREW, SELF-LOCKING: LP51959-13M, (03038)	EA	4								REF	REF		A8A2MP2H1
P--D		SCREW, SELF-LOCKING: LP51959-13M; (03038)	EA	REF								REF	REF		A8A2MP2H2
P--D		SCREW, SELF-LOCKING: LP51959-13M; (03038)	EA	REF								REF	REF		A8A2MP2H3
P--D		SCREW, SELF-LOCKING: LP51959-13M; (03038)	EA	REF								REF	REF		A8A2MP2H4
P--D	5915-846-0453	FILTER, MECHANICAL: 526-9376-000; (13499)	EA	1								*	*	3-21	A8A2FL1
P--D	5325-286-6047	GROMMET, RUBBER: MS35L89-1; (96906)	EA	1								*	*		A8A2H1
P-H-T	5820-975-5L26	MODULATOR, RADIO TRANSMITTER: 549-5688-004; (13499)	EA	1				*	*	*		*	*	3-20	A8A2E1
P--D		SCREW, SELF-LOCKING: NAS1190C04P3; (80205)	EA	REF								REF	REF		A8A2ELHL
X1-D		BOARD, PRINTED CIRCUIT, NO 1: 549-5690-004; (13499)	EA	1											A8A2E1E1
X1-D		CAPACITOR, FIXED, CERAMIC: 6S8082; (56289)	EA	2										3-20	A8A2E1C1
X1-D		CAPACITOR, FIXED, CERAMIC: 6S8082; (56289)	EA	REF										3-20	A8A2E1C34
X1-D		CAPACITOR, FIXED, ELECTROLYTIC: 29F461; (06001)	EA	1										3-20	A8JA2E106
X1-D		CAPACITOR, FIXED, ELECTROLYTIC: CL21BQ040SPE; (81349)	EA	1										3-20	A8A2E1C4
X1-D		CAPACITOR, FIXED, MICA: DM15C150J500VDC; (72136)	EA	1										3-20	A6A2E1C36*
* SELECT PER OPERATIONAL REQUIREMENT.															

SECTION II

TM 11-5820-509-35

REPAIR PARTS FOR DIRECT SUPPORT, GENERAL SUPPORT, AND DEPOT MAINTENANCE (Continued)															
(1) SMR CODE	(2) FEDERAL STOCK NUMBER	(3) DESCRIPTION Reference Number & Mfr. Code Usable on Code		(4) UNIT OF MEAS	(5) QTY INC IN UNIT	(6) 30 DAY DS MAINTENANCE ALLOWANCE			(7) 30 DAY GS MAINTENANCE ALLOWANCE			(8) 1 YR ALW PER 100 EQUIP CNTGCTY	(9) DEPOT MAINT ALW PER 100 EQUIP	(10) ILLUSTRATION	
						(a) 1-20	(b) 21-50	(c) 51-100	(a) 1-20	(b) 21-50	(c) 51-100			(a) FIG NO.	(b) ITEM NO. OR REFERENCE DESIGNATION
X1-D		CAPACITOR, FIXED, MICA: CM05CD180J03; (81349)		EA	1									3-20	A8A2E1C36*
X1-D		CAPACITOR, FIXED, MICA: CM05ED220J03; (81349)		EA	1									3-20	ASA2E1C36*
X1-D		CAPACITOR, FIXED, MICA: CMD5ED270J03; (81349)		EA	2									3-20	A8A2E1C9
X1-D		CAPACITOR, FIXED, MICA: CM05ED270J03; (81349)		EA	REF									3-20	A8A2E1C36*
X1-D		CAPACITOR, FIXED, MICA: CMDSED300J03; (81349)		EA	1									3-20	A8A2E1C36*
X1-D		CAPACITOR, FIXED, MICA: CMDSED330J03; (81349)		EA	1									3-20	A8A2E1C36*
X1-D		CAPACITOR, FIXED, MICA: CMDSED360J03; (81349)		EA	1									3-20	A8A2E1C36*
X1-D		CAPACITOR, FIXED, MICA: CM05FD221J03; (81349)		EA	2									3-20	A8A2E1C7
X1-D		CAPACITOR, FIXED, MICA: CM05FD221J03; (81349)		EA	REF									3-20	A8A2E1C8
X1-D		CAPACITOR, FIXED, MICA: DM20F22J0; (72136)		EA	1									3-20	A8A2E1C2
X1-D		CAPACITOR, VARIABLE, GLASS: SC156Y; (73899)		EA	1									3-20	A8A2E1C35
X1-D		COIL, RADIO FREQUENCY: LT10D036; (81349)		EA	1									3-20	A8A2E1L2
X1-D		COIL, RADIO FREQUENCY: LT10K053; (81349)		EA	2									3-20	A8A2E1L1L1
X1-D		COIL, RADIO FREQUENCY: LT10K053; (81349)		EA	REF									3-20	A8A2E1L3
X1-D		RESISTOR, FIXED, FILM: RN60C5110F; (81349)		EA	2									3-20	A8A2E1R4
X1-D		RESISTOR, FIXED, FILM: RN60C5110F; (81349)		EA	REF									3-20	A8A2E1R6
X1-D		RESISTOR, FIXED, FILM: RN60Db2R2F; (813b9)		EA	2									3-20	A8A2E1R7
X1-D		RESISTOR, FIXED, FILM: RN60D2R2F; (813b9)		EA	REF									3-20	A8A2E1R8
X1-D		RESISTOR, FIXED, FILM: RN60D1170F; (81349)		EA	1									3-20	A8A2E1R1
X1-D		RESISTOR, FIXED, FILM: RN60D1001F; (81349)		EA	1									3-20	A8A2E1R3
X1-D		RESISTOR, FIXED, FILM: RN60D7501F; (81349)		EA	1									3-20	A8A2E1R2
X1-D		RESISTOR, FIXED, FILM: RN65D1002F; (81349)		EA	1									3-20	A8A2E1R1
X1-D		RESISTOR, VARIABLE, WIRE WOUND: 224P1-201; (80294)		EA	1									3-20	A8A2E1R5
X1-D		SEMICONDUCTOR DEVICE SET: FA4092; (07263)		EA	1									3-20	A8A2E1CR1
P--D		RESISTOR, FIXED, COMPOSITION: RCR07G681KS; (81349)		EA	1							REF	REF	3-21	A8A2R45
*SELECT FOR OPERATIONAL REQUIREMENT															

SECTION II

TM 11-5820-509-35

REPAIR PARTS FOR DIRECT SUPPORT, GENERAL SUPPORT, AND DEPOT MAINTENANCE (Continued)															
(1) SMR CODE	(2) FEDERAL STOCK NUMBER	(3) DESCRIPTION Reference Number & Mfr. Code Usable on Code		(4) UNIT OF MEAS	(5) QTY INC IN UNIT	(6) 30 DAY DS MAINTENANCE ALLOWANCE			(7) 30 DAY GS MAINTENANCE ALLOWANCE			(8) 1 YR ALW PER 100 EQUIP CNTGCTY	(9) DEPOT MAINT ALW PER 100 EQUIP	(10) ILLUSTRATION	
						(a) 1-20	(b) 21-50	(c) 51-100	(a) 1-20	(b) 21-50	(c) 51-100			(a) FIG NO.	(b) ITEM NO. OR REFERENCE DESIGNATION
P--D	5905-816-8554	RESISTOR, FIXED, COMPOSITION: RCR07TC103KS; (81349)		EA	1							REF	REF	3-20	A8A2R27
P--D		SELFCONDUCTOR DEVICE, DIODE: 1N916; (07688)		EA	1							REF	REF	3-20	A8A2CR9
P--D	5340-984-7537	STRAP, RETAINING FILTER: 549-5660-002; (13499)		EA	1							*	*	3-21	A8A2MP3
P--D	5305-206-1270	SCREW, MACHINE: P343-0284-000; (T7250)		EA	1							REF	REF	3-21	AA2P3H1
P--D	5940-836-3536	TERMINAL, LUG: 4040-2HDSPL; (77147)		EA	3							*	*		A8A2E6
P--D	5940-836-3536	TERMINAL, LUG: 4040-2HDSPL; (77147)		EA	REF							REF	REF		A8A2E7
P--D	5940-836-3536	TERMINAK, LUG: 4040-2HDSPL; (77717)		EA	REF							REF	REP		A8A2E8
P--D	5940-455-7441	TERMTINAL, LUG: 4040-5HDSPL; (77147)		EA	1							*	*		A8A2E9
P--D		SCREW, MACHINE: P343-0285-00; (77250)		EA	1							*	*		A8A29HL
P--D		WASER, LOCK: 310-0396-00; (79807)		EA	1							REF	REF		A8A2E9M2
P-H-S	5820-087-0328	OSCILLATOR, RADIO FREQUENCY: 0-1032PRC47; (80058)		EA	1				*	*	*	*	*	3-4	A8A6
N--D		BLOCK, INSULATION, THERMAL: 549-1549-003; (13499)		EA	1										A8A6MP1
P--D		CAPACITOR, FIXED, MICA: DM15E191F050WV4CR; (72136)		EA	5							*	*		A8A6C14*
P--D		CAPACITOR, FIXED, MICA: DM15E191F050WV4CR; (72136)		EA	REF							REF	RIF		A8A6C20*
P--D		CAPACITOR, FIXED, MICA: DM15E191F050WV4CR; (72136)		EA	REF							REF	REF		A8A6C23*
P--D		CAPACITOR, FIXED, MICA: DM15E191F050WV4CR; (72136)		EA	REF							REF	REF		A8A6C29*
P--D		CAPACITOR, FIXED, MICA: DM15E191F050WV4CR; (72136)		EA	REF							REF	REF		A8A6C34*
P--D		CAPACITOR, FIXED, MICA: DM15E191F050WV4CR; (72136)		EA	5							*	*		A8A6C14*
P--D		CAPACITOR, FIXED, MICA: DM15E191F0500WV4CR; (72136)		EA	REF							REF	REF		A8A6C20*
P--D		CAPACITOR, FIXED, MICA: DM15E191f050WV4CR; (72136)		EA	REF							REF	REF		A8A6C23*
P--D		CAPACITOR, FIXED, MICA: DM15E191F0500WV4CR, (72136)		EA	REF							REF	REF		A8A6C29*
P--D		CAPACITOR, FIXED, MICA: DM15E191F0500WVCR; (72136)		EA	REF							REL	REF		A8A6C34*
P--D	5910-902-0031	CAPACITOR, FIXED, MICA: CMD5CDO50DO3, (81349)		EA	5							*	*		A8A6C14*
P--D	5910-902-0031	CAPACITOR, FIXED, MICA: CM05CD050D03, (81349)		EA	REF							REF	REF		A8A6C20*
P--D	5910-902-0031	CAPACITOR, FIXED, MICA:		EA	REF							REF	REF		A8A6C23*

*SELECT PER OPERATIONAL REQUIRED

SECTION II

TM 11-5820-509-35

REPAIR PARTS FOR DIRECT SUPPORT, GENERAL SUPPORT, AND DEPOT MAINTENANCE (Continued)															
(1) SMR CODE	(2) FEDERAL STOCK NUMBER	(3) DESCRIPTION Reference Number & Mfr. Code Usable on Code		(4) UNIT OF MEAS	(5) QTY INC IN UNIT	(6) 30 DAY DS MAINTENANCE ALLOWANCE			(7) 30 DAY GS MAINTENANCE ALLOWANCE			(8) 1 YR ALW PER 100 EQUIP CNTGCTY	(9) DEPOT MAINT ALW PER 100 EQUIP	(10) ILLUSTRATION	
						(a) 1-20	(b) 21-50	(c) 51-100	(a) 1-20	(b) 21-50	(c) 51-100			(a) FIG NO.	(b) ITEM NO. OR REFERENCE DESIGNATION
P--D	5910-902-0031	CAPACITOR, FIXED, MICA: CM05CD050D03; (81349)		EA	REF							REF	REF		A8A6C29*
P--D	5910-902-0031	CAPACITOR, FIXED, MICA: CM05CD050D03; (81349)		EA	REF							REF	REF		A8A6C34*
P--D	5910-902-0335	CAPACITOR, FIXED, MICA: CM05CD050D03; (81349)		EA	5							*	*		A8A6C14*
P--D	5910-902-0335	CAPACITOR, FIXED, MICA: CM05CD050D03; (81349)		EA	REF							REF	REF		A8A6C20*
P--D	5910-902-0335	CAPACITOR, FIXED, MICA: CM05CD050D03; (81349)		EA	REF							REF	REF		A8A6C23*
P--D	5910-902-0335	CAPACITOR, FIXED, MICA: CM05CD050D03; (81349)		EA	REF							REF	REF		A8A6C29*
P--D	5910-902-0335	CAPACITOR, FIXED, MICA: CM05CD050D03; (81349)		EA	REF							REF	REF		A8A6C34*
P--D	5910-936-7372	CAPACITOR, FIXED, MICA: CM05CD120J03; (81349)		EA	5							*	*		A8A6C14*
P--D	5910-936-7372	CAPACITOR, FIXED, MICA: CM05CD120J03; (81349)		EA	REF							REF	REF		A8A6C20*
P--D	5910-936-7372	CAPACITOR, FIXED, MICA: CM05CD120J03; (81349)		EA	REF							REF	REF		A8A6C23*
P--D	5910-936-7372	CAPACITOR, FIXED, MICA: CM05CD120J03; (81349)		EA	RKF							REF	REF		A8A6C29*
P--D	5910-936-7372	CAPACITOR, FIXED, MICA: CM05CD120J03; (81349)		EA	REF							REF	REF		AA6C34*
P--D		CAPACITOR, FIXED, MICA: DM15C150J500VDC; (72136)		EA	5							*	*		A8A6C19*
P--D		CAPACITOR, FIXED, MICA: DM15C150J500VDC; (72136)		EA	REF							REF	RKF		A8A6C20*
P--D		CAPACITOR, FIXED, MICA: DM15C150J500VDC; (72136)		EA	REF							REF	REF		A8A6C23*
P--D		CAPACITOR, FIXED, MICA: DM15C150J500VDC; (72136)		EA	REF							REF	REF		A8A6CR29*
P--D		CAPACITOR, FIXED, MICA: DM15C150J500VDC; (72136)		EA	RKF							REF	REF		A8A6C34*
P--D	5910-832-8080	CAPACITOR, FIXED, MICA: CM05ED200J03; (81349)		EA	5							*	*		A8A6C14*
P--D	5910-832-8080	CAPACITOR, FIXED, MICA: CM05ED200J03; (81349)		EA	REF							REF	REF		A8A6C20*
P--D	5910-832-8080	CAPACITOR, FIXED, MICA: CM05ED200J03; (81349)		EA	REF							REF	REF		AA6C23*
P--D	5910-832-8080	CAPACITOR, FIXED, MICA: CM05ED200J03; (81349)		EA	REF							REF	REF		A8A6C29*
P--D	5910-832-8080	CAPACITOR, FIXED, MICA: CM05ED200J03; (81349)		EA	REF							REF	REF		A8A6C34*
P--D	5910-954-5496	CAPACITOR, FIXED, MICA: CM05ED200J03; (81349)		EA	5							*	*		A8A6C14*
P--D	5910-954-5496	CAPACITOR, FIXED, MICA: CM05ED200J03; (81349)		EA	REF							REF	REF		A8A6C20*
P--D	5910-954-5496	CAPACITOR, FIXED, MICA: CM05ED200J03; (81349) *SELECT PER OPERATIONAL REQUIREMENT		EA	REF							REF	REF		A8A6C23*

SECTION II

TM 11-5820-509-35

REPAIR PARTS FOR DIRECT SUPPORT, GENERAL SUPPORT, AND DEPOT MAINTENANCE (Continued)															
(1) SMR CODE	(2) FEDERAL STOCK NUMBER	(3) DESCRIPTION Reference Number & Mfr. Code Usable on Code		(4) UNIT OF MEAS	(5) QTY INC IN UNIT	(6) 30 DAY DS MAINTENANCE ALLOWANCE			(7) 30 DAY GS MAINTENANCE ALLOWANCE			(8) 1 YR ALW PER 100 EQUIP CNTGCTY	(9) DEPOT MAINT ALW PER 100 EQUIP	(10) ILLUSTRATION	
						(a) 1-20	(b) 21-50	(c) 51-100	(a) 1-20	(b) 21-50	(c) 51-100			(a) FIG NO.	(b) ITEM NO. OR REFERENCE DESIGNATION
						P--D	5910-954-5496	CAPACITOR, FIXED MICA: CM05ED220J03; (81349)		EA	REF				
P--D	5910-954-5496	CAPACITOR, FIXED MICA: CM05ED220J03; (81349)		EA	REF							REF	REF		A9A6C34*
P--D	5910-051-4612	CAPACITOR, FIXED MICA: CM05ED220J03; (81349))		EA	5							*	*		ABA6C14*
P--D	5910-051-4612	CAPACITOR, FIXED MICA: CM05ED220J03; (81349))		EA	REF							REF	REF		A8A6C20*
P--D	5910-051-4612	CAPACITOR, FIXED MICA: CM05ED220J03; (81349)		EA	REF							REF	REF		A8A6C23*
P--D	5910-051-4612	CAPACITOR, FIXED MICA: CM05ED220J03; (81349)		EA	REF							REF	REF		A8AEC29*
P--D	5910-051-4612	CAPACITOR, FIXED MICA: CM05ED240J03; (81349)		EA	REF							REF	REF		A8A6C34*
P--D	5910-957-8578	CAPACITOR, FIXED MICA: CM05ED240J03; (81349)		EA	5								*		AA6BC14*
P--D	5910-957-8578	CAPACITOR, FIXED MICA: CM05ED240J03; (81349)		EA	REF							REF	REF		A6A6C20*
P--D	5910-957-8578	CAPACITOR, FIXED MICA: CM05ED240J03; (81349)		EA	REF							REF	REF		A8A6C23*
P--D	5910-957-8578	CAPACITOR, FIXED MICA: CM05ED240J03; (81349)		EA	REF							REF	REF		A8A6C29*
P--D		CAPACITOR, FIXED MICA: CM05ED270J03; (81349)		EA	REF							REF	REF		AYA6C34*
P--D		CAPACITOR, FIXED MICA: CM05ED270J03; (81349)		EA	5							*	*		A8A6C14 *
P--D		CAPACITOR, FIXED MICA: CM05ED270J03; (81349)		EA	REF							REF	REF		A8A6C20*
P--D		CAPACITOR, FIXED MICA: CM05ED270J03; (81349)		EA	REF							REF	REF		A8A6C23*
P--D		CAPACITOR, FIXED MICA: CM05ED270J03; (81349)		EA	REF							REF	REF		A8A6C29*
P--D		CAPACITOR, FIXED MICA: CM05ED270J03; (81349)		EA	REF							REF	REF		A8A6C34*
P--D		CAPACITOR, FIXED MICA: CM05ED300J03; (81349)		EA	5							*	*		AA6C14*
P--D		CAPACITOR, FIXED MICA: CM05ED300J03; (81349)		EA	REF							REF	REF		8A6C20*
P--D		CAPACITOR, FIXED MICA: CM05ED300J03; (81349)		EA	REF							REF	REF		A8A6C23*
P--D		CAPACITOR, FIXED MICA: CM05ED300J03; (81349)		EA	REF							REF	REF		A8A6C29*
P--D		CAPACITOR, FIXED MICA: CM05ED300J03; (81349)		EA	REF							REF	REF		A8A6C34*
P--D	5910-824-8036	CAPACITOR, FIXED MICA: CM05ED330J03; (81349)		EA	5							*	*		A8A6C14*
P--D	5910-824-8036	CAPACITOR, FIXED MICA: CM05ED330J03; (81349)		EA	REF							REF	REF		A8A6C20*
P--D	5910-824-8036	CAPACITOR, FIXED MICA: CM05ED330J03; (81349)		EA	REF							REF	REF		A8A6C23*

*SELECT PER OPERATIONAL REQUIREMENT.

SECTION II

TM 11-5820-509-35

REPAIR PARTS FOR DIRECT SUPPORT, GENERAL SUPPORT, AND DEPOT MAINTENANCE (Continued)															
(1) SMR CODE	(2) FEDERAL STOCK NUMBER	(3) DESCRIPTION Reference Number & Mfr. Code Usable on Code		(4) UNIT OF MEAS	(5) QTY INC IN UNIT	(6) 30 DAY DS MAINTENANCE ALLOWANCE			(7) 30 DAY GS MAINTENANCE ALLOWANCE			(8) 1 YR ALW PER 100 EQUIP CNTGCTY	(9) DEPOT MAINT ALW PER 100 EQUIP	(10) ILLUSTRATION	
						(a) 1-20	(b) 21-50	(c) 51-100	(a) 1-20	(b) 21-50	(c) 51-100			(a) FIG NO.	(b) ITEM NO. OR REFERENCE DESIGNATION
P--D	5910-824-8036	CAPACITOR, FIXED, MICA: CM05ED330J03; (81349)		EA	REF							REF	REF		A8A6C29*
P--D	5910-824-8036	CAPACITOR, FIXED, MICA: CM05ED330J03; (81349)		EA	REF							REF	REF		A8A6C34*
P--D	5910-964-6511	CAPACITOR, FIXED, MICA: CM05ED360J03; (813L9)		EA	5							*	*		A8A6C14*
P--D	5910-964-6511	CAPACITOR, FIXED, MICA: CM05ED360J03; (81349)		EA	REF							REF	REF		A8A6C20*
P--D	5910-964-6511	CAPACITOR, FIXED, MICA: CM05ED360J03; (81349)		EA	REF							REF	REF		A8A6C23*
P--D	5910-964-6511	CAPACITOR, FIXED, MICA: CM05ED360J03; (81349)		EA	REF							REF	REF		A8A6C29*
P--D	5910-964-6511	CAPACITOR, FIXED, MICA: CM05ED360J03; (81349)		EA	REF							REF	REF		A8A6C34*
P--D	5910-964-6511	CAPACITOR, FIXED, MICA: CM05ED390J03; (813L9)		EA	5							*	*		A8A6C14*
P--D	5910-964-6511	CAPACITOR, FIXED, MICA: CM05ED390J03; (81349)		EA	REF							REF	REF		A8A6C20*
P--D	5910-964-6511	CAPACITOR, FIXED, MICA: CM05ED390J03; (81349)		EA	REF							REF	REF		A8A6C23*
P--D	5910-964-6511	CAPACITOR, FIXED, MICA: CM05ED390J03; (81349)		EA	REF							REF	REF		A8A6C29*
P--D	5910-964-6511	CAPACITOR, FIXED, MICA: CM05ED390J03; (81349)		EA	REF							REF	REF		A8A6C34*
P--D	5910-964-6511	CAPACITOR, FIXED, MICA: CM05ED430J03; (81349)		EA	5							*	*		A8A6C14*
P--D	5910-964-6511	CAPACITOR, FIXED, MICA: CM05ED430J03; (81349)		EA	REF							REF	REF		A8A6C20*
P--D	5910-964-6511	CAPACITOR, FIXED, MICA: CM05ED430J03; (813L9)		EA	REF							REF	REF		A8A6C23*
P--D	5910-964-6511	CAPACITOR, FIXED, MICA: CM05ED430J03; (81349)		EA	REF							REF	REF		A8A6C29*
P--D	5910-964-6511	CAPACITOR, FIXED, MICA: CM05ED430J03; (81349)		EA	REF							REF	REF		A8A6C34*
P--D	5910-964-6511	CAPACITOR, FIXED, MICA: CM05ED470J03; (81349)		EA	5							*	*		A8A6C14*
P--D	5910-964-6511	CAPACITOR, FIXED, MICA: CM05ED470J03; (81349)		EA	REF							REF	REF		A8A6C20*
P--D	5910-964-6511	CAPACITOR, FIXED, MICA: CM05ED470J03; (81349)		EA	REF							REF	REF		A8A6C23*
P--D	5910-964-6511	CAPACITOR, FIXED, MICA: CM05ED470J03; (81349)		EA	REF							REF	REF		A8A6C29*
P--D	5910-964-6511	CAPACITOR, FIXED, MICA: CM05ED470J03; (81349)		EA	REF							REF	REF		A8A6C34*
P--D	5910-837-6687	CAPACITOR, FIXED, MICA: CM05ED510J03; (81349)		EA	5							*	*		A8A6C14*
P--D	5910-837-6687	CAPACITOR, FIXED, MICA: CM05ED510J03; (81349)		EA	REF							REF	REF		A8A6C20*
P--D	5910-837-6687	CAPACITOR, FIXED, MICA: CM05ED510J03; (81349)		EA	REF							REF	REF		A8A6C23*

*SELECT PER OPERATIONAL REQUIREMENT

SECTION II

TM 11-5820-509-35

REPAIR PARTS FOR DIRECT SUPPORT, GENERAL SUPPORT, AND DEPOT MAINTENANCE (Continued)															
(1) SMR CODE	(2) FEDERAL STOCK NUMBER	(3) DESCRIPTION Reference Number & Mfr. Code Usable on Code		(4) UNIT OF MEAS	(5) QTY INC IN UNIT	(6) 30 DAY DS MAINTENANCE ALLOWANCE			(7) 30 DAY GS MAINTENANCE ALLOWANCE			(8) 1 YR ALW PER 100 EQUIP CNTGCTY	(9) DEPOT MAINT ALW PER 100 EQUIP	(10) ILLUSTRATION	
						(a) 1-20	(b) 21-50	(c) 51-100	(a) 1-20	(b) 21-50	(c) 51-100			(a) FIG NO.	(b) ITEM NO. OR REFERENCE DESIGNATION
P--D		CAPACITOR, FIXED, MICA: CM05ED510J03; (81349)		EA	REF							REF	REF		A8A6C29*
P--D		CAPACITOR, FIXED, MICA: CM05ED510J03; (81349)		EA	REF							REF	REF		A8A6C34*
P--D	5910-825-5288	CAPACITOR, FIXED, MICA: CM05ED560J03; (81349)		EA	5							*	*		A8A6C14*
P--D	5910-825-5288	CAPACITOR, FIXED, MICA: CM05ED560J03; (81349)		EA	REF							REF	REF		A8A6C20*
P--D	5910-825-5288	CAPACITOR, FIXED, MICA: CM05ED560J03; (81349)		EA	REF							REF	REF		A8A6C23*
P--D	5910-825-5288	CAPACITOR, FIXED, MICA: CM05ED560J03; (81349)		EA	REF							REF	REF		A8A6C29*
P--D	5910-825-5288	CAPACITOR, FIXED, MICA: CM05ED560J03; (81349)		EA	REF							REF	REF		A8A6C34*
P--D		CAPACITOR, FIXED, MICA: CM05ED620J03; (81349)		EA	5							*	*		A8A6C14*
P--D		CAPACITOR, FIXED, MICA: CM05ED620J03; (81349)		EA	REF							REF	REF		A8A6C20*
P--D		CAPACITOR, FIXED, MICA: CM05ED620J03; (81349)		EA	REF							REF	REF		A8A6C23*
P--D		CAPACITOR, FIXED, MICA: CM05ED620J03; (81349)		EA	REF							REF	REF		A8A6C29*
P--D		CAPACITOR, FIXED, MICA: CM05ED620J03; (81349)		EA	REF							REF	REF		A8A6C34*
P--D		CAPACITOR, FIXED, MICA: CM05ED680J03; (81349)		EA	5							REF	REF		A8A6C14*
P--D		CAPACITOR, FIXED, MICA: CM05ED680J03; (81349)		EA	REF							REF	REF		A8A6C20*
P--D		CAPACITOR, FIXED, MICA: CM05ED680J03; (81349)		EA	REF							REF	REF		ABA6C23*
P--D		CAPACITOR, FIXED, MICA: CM05ED680J03; (81349)		EA	REF							REF	REF		A8A6C29*
P--D		CAPACITOR, FIXED, MICA: CM05ED680J03; (81349)		EA	REF							REF	REF		A8A6C34*
P--D	5910-814-0419	CAPACITOR, FIXED, MICA: CM05ED750J03; (81349)		EA	5							*	*		A8A6C14*
P--D	5910-814-0419	CAPACITOR, FIXED, MICA: CM05ED750J03; (81349)		EA	REF							REF	REF		A8A6C20*
P--D	5910-814-0419	CAPACITOR, FIXED, MICA: CM05ED750J03; (81349)		EA	REF							REF	REF		A8A6C23*
P--D	5910-814-0019	CAPACITOR, FIXED, MICA: CM05ED750J03; (81349)		EA	REF							REF	REF		A8A6C29*
P--D	5910-814-0419	CAPACITOR, FIXED, MICA: CM05ED750J03; (81349)		EA	REF							REF	REF		A8A6C34*
P--D	5910-578-1976	CAPACITOR, FIXED, MICA: CM05ED820J03; (81349)		EA	5							*	*		A8A6C14*
P--D	5910-578-1976	CAPACITOR, FIXED, MICA: CM05ED820J03; (81349)		EA	REF							REF	REF		A8A6C20*
P--D	5910-578-1976	CAPACITOR, FIXED, MICA: CM05ED820J03; (81349)		EA	REF							REF	REF		ABA6C23*

*ELECT PER OPERATIONAL REQUIREMINT.

SECTION II

TM 11-5820-509-35

REPAIR PARTS FOR DIRECT SUPPORT, GENERAL SUPPORT, AND DEPOT MAINTENANCE (Continued)															
(1) SMR CODE	(2) FEDERAL STOCK NUMBER	(3) DESCRIPTION Reference Number & Mfr. Code Usable on Code		(4) UNIT OF MEAS	(5) QTY INC IN UNIT	(6) 30 DAY DS MAINTENANCE ALLOWANCE			(7) 30 DAY GS MAINTENANCE ALLOWANCE			(8) 1 YR ALW PER 100 EQUIP CNTGCTY	(9) DEPOT MAINT ALW PER 100 EQUIP	(10) ILLUSTRATION	
						(a)	(b)	(c)	(a)	(b)	(c)			(a) FIG NO.	(b) ITEM NO. OR REFERENCE DESIGNATION
						1-20	21-50	51-100	1-20	21-50	51-100				
P--D	5910-578-1976	CAPACITOR, FIXED, MICA: CM05ED820J03; (81349)		EA	REF							REF	REF		A8A6C29*
P--D	5910-578-1976	CAPACITOR, FIXED, MICA: CM05ED820J03; (81349)		EA	REF							REF	REF		A8A6C34*
P--D		CAPACITOR, FIXED, MICA: CM05FD910J03; (81349)		EA	5							*	*		A8A6C14*
P--D		CAPACITOR, FIXED, MICA: CM05FD910J03; (81349)		EA	REF							REF	REF		A8A6C20*
P--D		CAPACITOR, FIXED, MICA: CM05FD910J03; (81349)		EA	REF							REF	REF		A8A6C23*
P--D		CAPACITOR, FIXED, MICA: CM05FD910J03; (81349)		EA	REF							REF	REF		A8A6C29*
P--D		CAPACITOR, FIXED, MICA: CM05FD910J03; (81349)		EA	REF							REF	REF		A8A6C34*
P--D		CAPACITOR, FIXED, MICA: CM05FD101J03; (81349)		EA	5							*	*		A8A6C14*
P--D		CAPACITOR, FIXED, MICA: CM05FD101J03; (81349)		EA	REF							REF	REF		A8A6C20*
P--D		CAPACITOR, FIXED, MICA: CMD5FD101J03; (81349)		EA	REF							REF	REF		A8A6C23*
P--D		CAPACITOR, FIXED, MICA: CMD5FD101J03; (81349)		EA	REF							REF	REF		A8A6C29*
P--D		CAPACITOR, FIXED, MICA: CMD5FD101J03; (81349)		EA	REF							REF	REF		A8A6C34*
P--D	5910-825-3067	CAPACITOR, FIXED, MICA: CM05FD111J03; (81349)		EA	5							*	*		A8A6C14*
P--D	5910-825-3067	CAPACITOR, FIXED, MICA: CM05FD111J03; (81349)		EA	REF							REF	REF		A8A6C20*
P--D	5910-825-3067	CAPACITOR, FIXED, MICA: CM05FD111J03; (81349)		EA	REF							REF	REF		A8A6C23*
P--D	5910-825-3067	CAPACITOR, FIXED, MICA: CMD5FD111J03; (81349)		EA	REF							REF	REF		A8A6C29*
P--D	5910-825-3067	CAPACITOR, FIXED, MICA: CM05FD111J03; (81349)		EA	REF							REF	REF		A8A6C34*
P--D	5910-954-5504	CAPACITOR, FIXED, MICA: CM05FD121J03; (81349)		EA	5							*	*		A8A6C14*
P--D	5910-954-5504	CAPACITOR, FIXED, MICA: CMD5FD121J03; (81349)		EA	REF							REF	REF		A8A6C20*
P--D	5910-954-5504	CAPACITOR, FIXED, MICA: CM05FD121J03; (81349)		EA	REF							REF	REF		A8A6C23*
P--D	5910-954-5504	CAPACITOR, FIXED, MICA: CM05FD121J031; (81349)		EA	REF							REF	REF		A8A6C29*
P--D	5910-954-5504	CAPACITOR, FIXED, MICA: CM05FD121J03; (81349)		EA	REF							REF	REF		A8A6C34*
P--D		CAPACITOR, FIXED, MICA: CM05FD131J03; (81349)		EA	5							*	*		A8A6C14*
P--D		CAPACITOR, FIXED, MICA: CM05FD131J03; (81349)		EA	REF							REF	REF		A8A6C20*
P--D		CAPACITOR, FIXED, MICA: CMD5FD131J03; (81349)		EA	REF							REF	REF		A8A6C23*

*SELECT PER OPERATIONAL REQUIREMENT.

SECTION II

TM 11-5820-509-35

REPAIR PARTS FOR DIRECT SUPPORT, GENERAL SUPPORT, AND DEPOT MAINTENANCE (Continued)															
(1) SMR CODE	(2) FEDERAL STOCK NUMBER	(3) DESCRIPTION Reference Number & Mfr. Code Usable on Code		(4) UNIT OF MEAS	(5) QTY INC IN UNIT	(6) 30 DAY DS MAINTENANCE ALLOWANCE			(7) 30 DAY GS MAINTENANCE ALLOWANCE			(8) 1 YR ALW PER 100 EQUIP CNTGCTY	(9) DEPOT MAINT ALW PER 100 EQUIP	(10) ILLUSTRATION	
						(a)	(b)	(c)	(a)	(b)	(c)			(a) FIG NO.	(b) ITEM NO. OR REFERENCE DESIGNATION
						1-20	21-50	51-100	1-20	21-50	51-100				
P--D		CAPACITOR, FIXED, MICA: CM05FD131J03; (813h9)		EA	REF							REF	REF		A8A6C29*
P--D		CAPACITOR, FIXED, MICA: CM05FD131J03; (813L9)		EA	REF							REF	REF		A8A6C34*
P--D		CAPACITOR, FIXED, MICA: CM05FD151J03; (81349)		EA	5							*	*		A8A6C14*
P--D		CAPACITOR, FIXED, MICA: CM05FD151J03; (81349)		EA	REF							REF	REF		A8A6C20*
P--D		CAPACITOR, FIXED, MICA: CM05FD151J03; (81349)		EA	REF							REF	REF		A8A6C23*
P--D		CAPACITOR, FIXED, MICA: CM05FD151J03; (81349)		EA	REF							REF	REF		A8A6C29*
P--D		CAPACITOR, FIXED, MICA: CM05FD151J03; (81349)		EA	REF							REF	REF		A8A6C34*
P--D		CAPACITOR, FIXED, MICA: CM05FD161J03; (81349)		A	5							*	*		A8A6C14*
P--D		CAPACITOR, FIXED, MICA: CM05FD161J03; (81349)		EA	REF							REF	REF		A8A6C20*
P--D		CAPACITOR, FIXED, MICA: CM05FD161J03; (81349)		EA	REF							REF	REF		A8A6C23*
P--D		CAPACITOR, FIXED, MICA: CM05FD161J03; (81349)		EA	REF							REF	REF		A8A6C29*
P--D		CAPACITOR, FIXED, MICA: CM05FD161J03; (81349)		EA	REF							REF	REF		A8A6C34*
P--D		CAPACITOR, FIXED, MICA: CM05FD181J03; (81349)		EA	5							*	*		AA6C14*
P--D		CAPACITOR, FIXED, MICA: CM05FD181J03; (81349)		EA	REF							REF	REF		AA6C20*
P--D		CAPACITOR, FIXED, MICA: CM05FD181J03; (81349)		EA	REF							REF	REF		A8A6C23*
P--D		CAPACITOR, FIXED, MICA: CM05FD181J03; (81349)		EA	REF							REF	REF		A8A6C29*
P--D		CAPACITOR, FIXED, MICA: CM05FD181J03; (81349)		EA	REF							REF	REF		A8A6C34*
P--D		CAPACITOR, FIXED, MICA: CM05FD181J03; (81349)		EA	5							*	*		A8A6C14*
P--D		CAPACITOR, FIXED, MICA: CM05FD201J03; (81349)		EA	REF							REF	REF		A8A6C20*
P--D		CAPACITOR, FIXED, MICA: CM05FD201J03; (81349)		EA	REF							REF	REF		A8A6C23*
P--D		CAPACITOR, FIXED, MICA: CM05FD201J03; (81349)		EA	REF							REF	REF		A8A6C29*
P--D		CAPACITOR, FIXED, MICA: CM05FD201J03; (81349)		EA	REF							REF	REF		A8A6C34*
P--D		CAPACITOR, FIXED, MICA: CM05FD221J03; (81349)		EA	5							*	*		A8A6C14*
P--D		CAPACITOR, FIXED, MICA: CM05FD221J03; (81349)		EA	REF							REF	REF		A8A6C20*
P--D		CAPACITOR, FIXED, MICA: CM05FD221J03; (81349)		EA	REF							REF	REF		A8A6C23*

*SELECT PER OPERATIONAL REQUIREMENT.

SECTION II

TM 11-5820-509-35

REPAIR PARTS FOR DIRECT SUPPORT, GENERAL SUPPORT, AND DEPOT MAINTENANCE (Continued)															
(1) SMR CODE	(2) FEDERAL STOCK NUMBER	(3) DESCRIPTION Reference Number & Mfr. Code Usable on Code		(4) UNIT OF MEAS	(5) QTY INC IN UNIT	(6) 30 DAY DS MAINTENANCE ALLOWANCE			(7) 30 DAY GS MAINTENANCE ALLOWANCE			(8) 1 YR ALW PER 100 EQUIP CNTGCTY	(9) DEPOT MAINT ALW PER 100 EQUIP	(10) ILLUSTRATION	
						(a)	(b)	(c)	(a)	(b)	(c)			(a)	(b)
						1-20	21-50	51-100	1-20	21-50	51-100			FIG NO.	ITEM NO. OR REFERENCE DESIGNATION
P--D	5910-460-0869	CAPACITOR, FIXED, MICA: CM05FD221J03; (81349)		EA	REF							REF	REF		A8A6C29*
P--D	5910-460-0869	CAPACITOR, FIXED, MICA: CM05FD221J03; (81349)		EA	REF							REF	REF		A8A6C34*
P--D	5910-456-0797	CAPACITOR, FIXED, MICA: CM05FD241J03; (81349)		EA	5							*	*		A8A6C11*
P--D	5910-456-0797	CAPACITOR, FIXED, MICA: CM05FD241J03; (81349)		EA	REF							REF	REF		A8A6C20*
P--D	5910-456-0797	CAPACITOR, FIXED, MICA: CM05FD241J03; (81349)		EA	REF							REF	REF		A8A6C23*
P--D	5910-456-0797	CAPACITOR, FIXED, MICA: CM05FD241J03; (81349)		EA	REF							REF	REF		A8A6C29*
P--D	5910-456-0797	CAPACITOR, FIXED, MICA: CM05FD241J03; (81349)		EA	REF							REF	REF		A8A6C34*
P--D	5910-456-0797	CAPACITOR, FIXED, MICA: CM05FD271J03; (81349)		EA	5							*	*		A8A6C11*
P--D	5910-456-0797	CAPACITOR, FIXED, MICA: CM05FD271J03; (81349)		EA	REF							REF	REF		A8A6C20*
P--D	5910-456-0797	CAPACITOR, FIXED, MICA: CM05FD271J03; (81349)		EA	REF							REF	REF		A8A6C23*
P--D	5910-456-0797	CAPACITOR, FIXED, MICA: CM05FD271J03; (81349)		EA	REF							REF	REF		A8A6C29*
P--D	5910-456-0797	CAPACITOR, FIXED, MICA: CM05FD271J03; (81349)		EA	REF							REF	REF		A8A6C34*
P--D	5910-456-0793	CAPACITOR, FIXED, MICA: CM05FD301J03; (81349)		EA	5							*	*		A8A6C14*
P--D	5910-456-0793	CAPACITOR, FIXED, MICA: CM05FD301J03; (81349)		EA	REF							REF	REF		A8A6C20*
P--D	5910-456-0793	CAPACITOR, FIXED, MICA: CM05FD301J03; (81349)		EA	REF							REF	REF		A8A6C23*
P--D	5910-456-0793	CAPACITOR, FIXED, MICA: CM05FD301J03; (81349)		EA	REF							REF	REF		A8A6C29*
P--D	5910-456-0793	CAPACITOR, FIXED, MICA: CM05FD301J03; (81349)		EA	REF							REF	REF		A8A6C34*
P--D	5910-456-0793	CAPACITOR, FIXED, MICA: CM05FD301J03; (81349)		EA	5							*	*		A8A6C14*
P--D	5910-456-0793	CAPACITOR, FIXED, MICA: CM05FD331J03; (81349)		EA	REF							REF	REF		A8A6C20*
P--D	5910-456-0793	CAPACITOR, FIXED, MICA: CM05FD331J03; (81349)		EA	REF							REF	REF		A8A6C23*
P--D	5910-456-0793	CAPACITOR, FIXED, MICA: CM05FD331J03; (81349)		EA	REF							REF	REF		A8A6C29*
P--D	5910-456-0793	CAPACITOR, FIXED, MICA: CM05FD331J03; (81349)		EA	REF							REF	REF		A8A6C34*
P--D	5910-456-0793	CAPACITOR, FIXED, MICA: CM05FD361J03; (81349)		EA	5							*	*		A8A6C14*
P--D	5910-456-0793	CAPACITOR, FIXED, MICA: CM05FD361J03; (81349)		EA	REF							REF	REF		A8A6C20*
P--D	5910-456-0793	CAPACITOR, FIXED, MICA: CM05FD361J03; (81349)		EA	REF							REF	REF		A8A6C23*

*SELECT PER OPERATIONAL REQUIREMENT

SECTION II

TM 11-5820-509-35

REPAIR PARTS FOR DIRECT SUPPORT, GENERAL SUPPORT, AND DEPOT MAINTENANCE (Continued)															
(1) SMR CODE	(2) FEDERAL STOCK NUMBER	(3) DESCRIPTION Reference Number & Mfr. Code Usable on Code		(4) UNIT OF MEAS	(5) QTY INC IN UNIT	(6) 30 DAY DS MAINTENANCE ALLOWANCE			(7) 30 DAY GS MAINTENANCE ALLOWANCE			(8) 1 YR ALW PER 100 EQUIP CNTGCTY	(9) DEPOT MAINT ALW PER 100 EQUIP	(10) ILLUSTRATION	
						(a) 1-20	(b) 21-50	(c) 51-100	(a) 1-20	(b) 21-50	(c) 51-100			(a) FIG NO.	(b) ITEM NO. OR REFERENCE DESIGNATION
P--D	5910-255-1608	CAPACITOR, FIXED, MICA: CM05FD361J03, (81349)		EA	REF							REF	REF		A8A6C29*
P--D	5910-255-1608	CAPACITOR, FIXED, MICA: CM05FD361J03, (81349)		EA	REF							REF	REF		A8A6C34*
P--D		CAPACITOR, FIXED, MICA: CM05FD391J03, (81349)		EA	5							*	*		A8A6C14*
P--D		CAPACITOR, FIXED, MICA: CM50'D391J03; (81349)		EA	REF							REF	REF		A8A6C20*
P--D		CAPACITOR, FIXED, MICA: CM05FD391J03, (813h9)		EA	REF							REF	REF		A8A6C23*
P--D		CAPACITOR, FIXED, MICA: CM05FD391J03, (81349)		EA	REF							REF	REF		A8A6C29*
P--D		CAPACITOR, FIXED, MICA: CM05FD391J03, (81349)		EA	REF							REF	REF		A8A6C34*
P--D	5910-023-2068	CAPACITOR, FIXED, MICA: DM15F131J300WV4CR; (72136)		EA	5							*	*		AA6C114*
P--D	5910-023-2068	CAPACITOR, FIXED, MICA: DM15F431J300WV4CR; (72136)		EA	REF							REF	REF		A8A6C20*
P--D	5910-023-2068	CAPACITOR, FIXED, MICA: DM15F431J300WV4CR; (72136)		EA	REF							REF	REF		A8A6C23*
P--D	5910-023-2068	CAPACITOR, FIXED, MICA: DM15F1471J300WV4CR; (72136)		EA	REF							REF	REF		A8A6C29*
P--D	5910-023-2068	CAPACITOR, FIXED, MICA: DM15F4311J300WV4CR; (72136)		EA	REF							REF	REF		A8A6C34*
P--D	5910-997-5399	CAPACITOR, FIXED, MICA: DM15F471J300WV4CR; (72136)		EA	5							*	*		A8A6C14*
P--D	5910-997-5399	CAPACITOR, FIXED, MICA: DM15F471J300WV4CR; (72136)		EA	REF							REF	REF		A8A6C20*
P--D	5910-997-5399	CAPACITOR, FIXED, MICA: DM15F471J300WV4CR; (72156)		EA	REF							REF	REF		A8A6C23*
P--D	5910-997-5399	CAPACITOR, FIXED, MICA: DM15F471J300WV4CR; (72136)		EA	REF							REF	REF		A8A6C29*
P--D	5910-997-5399	CAPACITOR, FIXED, MICA: DM15F471J300WV4CR; (72136)		EA	REF							REF	REF		A8A6C34*
P--D	5910-686-6126	CAPACITOR, FIXED, MICA: DM15F511J300WV4CR; (72136)		EA	5							*	*		AA6C1*
P--D	5910-686-6126	CAPACITOR, FIXED, MICA: DM15F511J300V4CR; (72136)		EA	REF							REF	REF		A8A6C20*
P--D	5910-686-6126	CAPACITOR, FIXED, MICA: DM15F511J300WV4CR; (72136)		EA	REF							REF	REF		A8A6C23*
P--D	5910-686-6126	CAPACITOR, FIXED, MICA: DM15F511J300WV4CR; (72136)		EA	REF							REF	REF		A8A6C29*
P--D	5910-686-6126	CAPACITOR, FIXED, MICA: DM15F511J300WV4CR; (72136)		EA	REF							REF	REF		A8A6C34*
P--D	5910-958-8257	CAPACITOR, FIXED, MICA: DM15E621J0300WV4CR; (72136)		EA	5							*	*		A8A6C14*
P--D		CAPACITOR, FIXED, MICA: DM15E621J0300WV4CR; (72136)		EA	REF							REF	REF		A8A6C20*
P--D		CAPACITOR, FIXED, MICA: DM15E621J0300WV4CR; (72136)		EA	REF							REF	REF		A8A6C23*

*SELECT PER OPERATIONAL REQUIREMENT.

SECTION II

TM 11-5820-509-35

REPAIR PARTS FOR DIRECT SUPPORT, GENERAL SUPPORT, AND DEPOT MAINTENANCE (Continued)															
(1) SMR CODE	(2) FEDERAL STOCK NUMBER	(3) DESCRIPTION Reference Number & Mfr. Code Usable on Code		(4) UNIT OF MEAS	(5) QTY INC IN UNIT	(6) 30 DAY DS MAINTENANCE ALLOWANCE			(7) 30 DAY GS MAINTENANCE ALLOWANCE			(8) 1 YR ALW PER 100 EQUIP CNTGCTY	(9) DEPOT MAINT ALW PER 100 EQUIP	(10) ILLUSTRATION	
						(a) 1-20	(b) 21-50	(c) 51-100	(a) 1-20	(b) 21-50	(c) 51-100			(a) FIG NO.	(b) ITEM NO. OR REFERENCE DESIGNATION
P--D	5910-958-8257	CAPACITOR, FIXED, MICA DM15E621J0300WV4CR, (72136)		EA	REF							REF	REF		A8A6C29 *
P--D	5910-958-8257	CAPACITOR, FIXED, MICA DN15E621J0300WV4CR, (72136)		EA	REF							REF	REF		A8A6C34 *
P--D		CAPACITOR, FIXED, MICA- CM06FD751J03; (81349)		EA	5							*	*		A8A6C14.*
P--D		CAPACITOR, FIXED, MICA: CM06FD751J3, (81349)		EA	REF							REF	REF		A8A6C20 *
P--D		CAPACITOR, FIXED, MICA. CM06FD751J03; (81349)		EA	REF							REF	REF		A8A6C23 *
P--D		CAPACITOR, FIXED, MICA- CM06FD751J03, (81349)		EA	REF							REF	REF		A8A6C29 *
P--D		CAPACITOR, FIXED, MICA: CM06FD751J03, (81349)		EA	REF							REF	REF		A8A6C34 *
P--D	5910-851-3328	CAPACITOR, FIXED, MICA: DM15E821J0300WV4CR, (72136)		EA	5										A8A6C14 *
P--D		CAPACITOR, FIXED, MICA: DM15E821J0300WV4CR, (72136)		EA	REF							REF	REF		A8A6C20.*
P--D		CAPACITOR, FIXED, MICA DM15E821J0300WV4CR, (72136)		EA	REF							REF	REF		A8A6C23 *
P--D		CAPACITOR, FIXED, MICA. DM15E821J0300WV4CR, (72136)		EA	REF							REF	REF		A8A6C29 *
P--D		CAPACITOR, FIXED, MICA DM15E821J0300WV4CR, (72136)		EA	REF							REF	REF		A8A6C34 *
P--D	5910-878-5239	CAPACITOR, FIXED, MICA DM15E1690F0300WVCR, (72136)		EA	5							*	*		A8A6C14 *
P--D	5910-878-5239	CAPACITOR, FIXED, MICA- DM15E1690F0300WV4CR, (72136)		EA	REF							REF	REF		A8A6C20.*
P--D	5910-878-5239	CAPACITOR, FIXED, MICA DM15E1690F0300WV4CR, (72136)		EA	REF							REF	REF		A8A6C23 *-
P--D	5910-878-5239	CAPACITOR, FIXED, MICA DM15E1690F0300WV4CR, (72136)		EA	REF							REF	REF		A8A6C29 *
P--D	5910-878-5239	CAPACITOR, FIXED, MICA DM15E1690F0300WV4CR, (72136)		EA	REF							REF	REF		A8A6C34.*
P--D		CAPACITOR, FIXED, MICA DM15F561J300WV4CR, (72136)		EA	5							*	*		A8A6C14 *
P--D		CAPACITOR, FIXED, MICA DM15F561J300WV4CR, (72136)		EA	REF							REF	REF		A8A6C20.*
P--D		CAPACITOR, FIXED, MICA DM15F561J300WV4CR, (72136)		EA	REF							REF	REF		A8A6C23 *
P--D		CAPACITOR, FIXED, MICA DM15F561J300WV4CR, (7213 6)		EA	REF							REF	REF		A8A6C29 *
P--D		CAPACITOR, FIXED, MICA DM15F561J300WV4CR, (72136)		EA	REF							REF	REF		A8A6C34.*
P--D	5935-811-1382	CONNECTOR, RECEPTACLE, ELECTRICAL DBM13W3P; (71468)		EA	1							REF	REF	3-52	A8A6P1
P--D	5310-934-9740	NUT, PLAIN, HEXAGON: MS35649-225, (96906)		EA	1							REF	REF		A8A6P1H1
P--D	5305-151-0732	SCREW, MACHINE P342-0143-000, (77250)		EA	2							*	*		A8A6P1H2
														* SELECT PER OPERATIONAL REQUIREMENT.	

SECTION II

TM 11-5820-509-35

REPAIR PARTS FOR DIRECT SUPPORT, GENERAL SUPPORT, AND DEPOT MAINTENANCE.(Continued)															
(1) SMR CODE	(2) FEDERAL STOCK NUMBER	(3) DESCRIPTION Reference Number & Mfr. Code Usable on Code		(4) UNIT OF MEAS	(5) QTY INC IN UNIT	(6) 30 DAY DS MAINTENANCE ALLOWANCE			(7) 30 DAY GS MAINTENANCE ALLOWANCE			(8) 1 YR ALW PER 100 EQUIP CNTGCTY	(9) DEPOT MAINT ALW PER 100 EQUIP	(10) ILLUSTRATION	
						(a)	(b)	(c)	(a)	(b)	(c)			(a) FIG NO.	(b) ITEM NO. OR REFERENCE DESIGNATION
						1-20	21-50	51-100	1-20	21-50	51-100				
P--D	5305-151-0732	SCREW, MACHINE P342-0143-000, (77250)		EA	REF							REF	REF		A8A6P1H3
P--D	5310-316-9040	WASHER, FLAT- 310-0053-000, (79807)		EA	2							*	*		A8A6P1H4
P--D	5310-316-9040	WASHER, FLAT 310-0053-000, (79807)		EA	REF							REF	REF		A8A6P1H5
P--D	5310-981-2255	WASHER, SPRING TENSION 310-0074-000, (79807)		EA	2							*	*		A8A6P1H6
P--D	5310-981-2255	WASHER, SPRING TENSION 310-0074-000, (79807)		EA	REF							REF	REF		A8A6P1H7
P--D	5935-885-6505	CONTACT,ELECTRICAL,COAXIALINSERT DM53740-5000, (71468)		EA	3							REF	REF		ABA6P1A1
P--D	5935-885-6505	CONTACT,ELECTRICAL,COAXIALINSERT D453740-5000, (71468)		EA	REF							REF	REF		A8A6P1A2
P--D	5935-885-6505	CONTACT,ELECTRICAL,COAXIALINSERT DM53740-5000, (71468)		EA	REF							REF	REF		A8A6P1A3
M--D		COVER, OSCILLATOR-RIVETED 549-1544-003, (13499)		EA	1										A8A6MP2
P--D	5305-054-6651	SCREW, MACHINE MS51957-27, (96906)		EA	2								*	*	A8A6MP2H1
P--D	5305-054-6651	SCREW, MACHINE MS51957-27, (96906)		EA	REF							REF	REF		A8A6MP2H2
P--D	5310-515-8243	WASHER, FLAT 310-00006-000, (79807)		EA	2							*	*		A8A614P2H3
P--D	5310-515-8243	WASHER, FLAT 310-00006-000, (79807)		EA	REF							REF	REF		A8A6MP2H4
P--F-T	5820-088-1379	DIVIDER, FREQUENCY-100KC 549-1553-004, (13499)		EA	1	*	*	*	*	*	*	*	*	3-12	A8A6E1
P--D	5305-059-8228	SCREW, MACHINE P343-0299-000, (77250)		EA	6							*	*	3-52	A8A6E1H6
P--D	5310-981-2255	WASHER, SPRING TENSION 310-0074-000, (79807)		EA	6							REF	REF		A8A6E1H6
X1-D		BOARD, TERMINAL-PRESSED 549-1551-003, (13499)		EA	1									3-52	A8A6E1TB1
X1-D		CAPACITOR, FIXED, CERAMIC CK13BX223M, (81349)		EA	1									3-52	A8A6E1C32
X1-D		CAPACITOR, FIXED, CERAMIC. K13BX103K, (81349)		EA	1									3-52	A8A6E1C35
X1-D		CAPACITOR, FIXED, ELECTROLYTIC 150D105X0035A2, (56289.)		EA	2									3-52	A8A6E1C37
X1-D		CAPACITOR, FIXED, ELECTROLYTIC 150D105X0035A2, (56289)		EA	REF									3-52	A8A6E1C38
X1-D		CAPACITOR, FIXED, FILM 192P1039R8, (56289)		EA	1									3-52	A8A6E1C30
X1-D		CAPACITOR, FIXED, FILM 192P4739R8, (56289)		EA	1									3-52	A8A6E1C31
X1-D		CAPACITOR, FIXED, MICA CM06FD242J03, (81349)		EA	1									3-52	A8A6E1C28
X1-D		CAPACITOR, FIXED, MICA. CM06FD272F03, (81349)		EA	1									3-52	A8A6E1C33

SECTION II

REPAIR PARTS FOR DIRECT SUPPORT, GENERAL SUPPORT, AND DEPOT MAINTENANCE.(Continued)

(1) SMR CODE	(2) FEDERAL STOCK NUMBER	(3) DESCRIPTION Reference Number & Mfr. Code Usable on Code	(4) UNIT OF MEAS	(5) QTY INC IN UNIT	(6) 30 DAY DS MAINTENANCE ALLOWANCE			(7) 30 DAY GS MAINTENANCE ALLOWANCE			(8) 1 YR ALW PER 100 EQUIP CNTGCTY	(9) DEPOT MAINT ALW PER 100 EQUIP	(10) ILLUSTRATION	
					(a)	(b)	(c)	(a)	(b)	(c)			(a)	(b)
					1-20	21-50	51-100	1-20	21-50	51-100			FIG NO.	ITEM NO. OR REFERENCE DESIGNATION
X1-D		CAPACITOR, FIXED, MICA DM15E102J0100WV4CR, (72136)	EA	1								3-52	A8A6E1C27	
X1-D		COIL, RADIO FREQUENCY LT10K037, (813L9)	EA	1								3-52	A8A6E1L8	
X1-D		COIL, RADIO FREQUENCY LT10K043, (81349)	EA	1								3-52	A8A6E1L7	
X1-D		COIL, RADIO FREQUENCY LT10K060, (81349)	EA	1								3-52	A8A6E1L9	
X1-D		GROMMET, RUBBER MS35489-4, (96906)	EA	3								3-52	A8A6E1H1	
X1-D		GROMMET, RUBBER MS35489-4, (96906)	EA	REF								3-52	A8A6E1H2	
X1-D		GROMMET, RUBBER MS35489-4, (96906)	EA	REF								3-52	ABA6E1H3	
X1-D		RESISTOR, FIXED, COMPOSITION RCR07G222KS, (81349)	EA	1								3-52	A8A6E1R36	
X1-D		RESISTOR, FIXED, COMPOSITION RCR07G472KS, (81349)	EA	5								3-52	A8A6E1R34	
X1-D		RESISTOR, FIXED, COMPOSITION RCR07G472KS, (81349)	EA	REF								3-52	A8A6E1R38	
X1-D		RESISTOR, FIXED, COMPOSITION RCR07G472KS, (81349)	EA	REF								3-52	A8A6E1R39	
X1-D		RESISTOR, FIXED, COMPOSITION RCR07G472KS, (81349)	EA	REF								3-52	A8A6ERL40	
X1-D		RESISTOR, FIXED, COMPOSITION RCR07GC72KS, (81349)	EA	REF								3-52	A8A6E1R43	
X1-D		RESISTOR, FIXED, COMPOSITION. RCR07G103KS, (81349)	EA	4								3-52	A8A6E1R35	
X1-D		RESISTOR, FIXED, COPOSITION RCR07G103KS, (81349)	EA	REF								3-52	A8A6E1R37	
X1-D		RESISTOR, FIXED, COMPOSITION RCR07G103KS, (81349)	EA	REF								3-52	A8A6E1R41	
X1-D		RESISTOR, FIXED, COMPOSITION RCR07G103KS, (81349)	EA	REF								3-52	A8A6E1R42	
X1-D		RESISTOR, FIXED, FILM R60D26R1F, (81349)	EA	1								3-52	A8A6E1R44	
X1-D		TERMINAL, STUD-GROUD AB396-1, (12615)	EA	6									A8A6E1E	
X1-D		SCREW, MACHINE P343-0298-00000, (77250)	EA	1									A8A6E1E1H	
X1-D		WASHER, SPRING TENSION 310-0074-000, (79807)	EA	1									A8A6E1E1H2	
X1-D		TERMINAL, STUD-GROUND AB396-1, (12615)	EA	REF									A8A6E1E2	
X1-D		SCREW, MACHINE P343-0298-00, (77250)	EA	1									A8A6E1E2H1	
X1-D		WASHER, SPRING TENSION 310-0074-000, (79807)	EA	1									A8A6E1E2H2	
X1-D		TERMINAL, STUD-GROUND AB396-1, (12615)	EA	REF									A8A6E1E3	

SECTION II

TM 11-5820-509-35

REPAIR PARTS FOR DIRECT SUPPORT, GENERAL SUPPORT, AND DEPOT MAINTENANCE.(Continued)															
(1) SMR CODE	(2) FEDERAL STOCK NUMBER	(3) DESCRIPTION Reference Number & Mfr. Code Usable on Code		(4) UNIT OF MEAS	(5) QTY INC IN UNIT	(6) 30 DAY DS MAINTENANCE ALLOWANCE			(7) 30 DAY GS MAINTENANCE ALLOWANCE			(8) 1 YR ALW PER 100 EQUIP CNTGCTY	(9) DEPOT MAINT ALW PER 100 EQUIP	(10) ILLUSTRATION	
						(a)	(b)	(c)	(a)	(b)	(c)			(a) FIG NO.	(b) ITEM NO. OR REFERENCE DESIGNATION
						1-20	21-50	51-100	1-20	21-50	51-100				
X1-D		CAPACITOR, FIXED, MICA DM15E102J0100WV4CR, (72136)		EA	1									3-52	A8A6E1C27
X1-D		COIL, RADIO FREQUENCY LT10K037, (813L9)		EA	1									3-52	A8A6E1L8
X1-D		COIL, RADIO FREQUENCY LT10K043, (81349)		EA	1									3-52	A8A6E1L7
X1-D		COIL, RADIO FREQUENCY LT10K060, (81349)		EA	1									3-52	A8A6E1L9
X1-D		GROMMET, RUBBER MS35489-4, (96906)		EA	3									3-52	A8A6E1H1
X1-D		GROMMET, RUBBER MS35489-4, (96906)		EA	REF									3-52	A8A6E1H2
X1-D		GROMMET, RUBBER MS35489-4, (96906)		EA	REF									3-52	ABA6E1H3
X1-D		RESISTOR, FIXED, COMPOSITION RCR07G222KS, (81349)		EA	1									3-52	A8A6E1R36
X1-D		RESISTOR, FIXED, COMPOSITION RCR07G472KS, (81349)		EA	5									3-52	A8A6E1R34
X1-D		RESISTOR, FIXED, COMPOSITION RCR07G472KS, (81349)		EA	REF									3-52	A8A6E1R38
X1-D		RESISTOR, FIXED, COMPOSITION RCR07G472KS, (81349)		EA	REF									3-52	A8A6E1R39
X1-D		RESISTOR, FIXED, COMPOSITION RCR07G472KS, (81349)		EA	REF									3-52	A8A6ERL40
X1-D		RESISTOR, FIXED, COMPOSITION RCR07GC72KS, (81349)		EA	REF									3-52	A8A6E1R43
X1-D		RESISTOR, FIXED, COMPOSITION. RCR07G103KS, (81349)		EA	4									3-52	A8A6E1R35
X1-D		RESISTOR, FIXED, COPOSITION RCR07G103KS, (81349)		EA	REF									3-52	A8A6E1R37
X1-D		RESISTOR, FIXED, COMPOSITION RCR07G103KS, (81349)		EA	REF									3-52	A8A6E1R41
X1-D		RESISTOR, FIXED, COMPOSITION RCR07G103KS, (81349)		EA	REF									3-52	A8A6E1R42
X1-D		RESISTOR, FIXED, FILM R60D26R1F, (81349)		EA	1									3-52	A8A6E1R44
X1-D		TERMINAL, STUD-GROUD AB396-1, (12615)		EA	6										A8A6E1E
X1-D		SCREW, MACHINE P343-0298-00000, (77250)		EA	1										A8A6E1E1H
X1-D		WASHER, SPRING TENSION 310-0074-000, (79807)		EA	1										A8A6E1E1H2
X1-D		TERMINAL, STUD-GROUND AB396-1, (12615)		EA	REF										A8A6E1E2
X1-D		SCREW, MACHINE P343-0298-00, (77250)		EA	1										A8A6E1E2H1
X1-D		WASHER, SPRING TENSION 310-0074-000, (79807)		EA	1										A8A6E1E2H2
X1-D		TERMINAL, STUD-GROUND AB396-1, (12615)		EA	REF										A8A6E1E3

SECTION II

TM 11-5820-509-35

REPAIR PARTS FOR DIRECT SUPPORT, GENERAL SUPPORT, AND DEPOT MAINTENANCE (Continued)															
(1) SMR CODE	(2) FEDERAL STOCK NUMBER	(3) DESCRIPTION Reference Number & Mfr. Code Usable on Code		(4) UNIT OF MEAS	(5) QTY INC IN UNIT	(6) 30 DAY DS MAINTENANCE ALLOWANCE			(7) 30 DAY GS MAINTENANCE ALLOWANCE			(8) 1 YR ALW PER 100 EQUIP CNTGCTY	(9) DEPOT MAINT ALW PER 100 EQUIP	(10) ILLUSTRATION	
						(a) 1-20	(b) 21-50	(c) 51-100	(a) 1-20	(b) 21-50	(c) 51-100			(a) FIG NO.	(b) ITEM NO. OR REFERENCE DESIGNATION
						X1-D		SCREW, MACHINE: P343-0298-000; (77250)	EA	1					
X1-D		WASHER, SPRING TENSION: 310-0074-000; (79807)	EA	1											A8A6E1E3H2
X1-D		TERMINAL, STUD-GROUND: AB396-1; (12615)	EA	REF											A8A6E1E4
X1-D		SCREW, MACHINE: P343-0298-000; (77250)	EA	1											A8A6E1E4H1
X1-D		WASHER, SPRING TENSION: 310-0074-000; (79807)	EA	1											A8A6E1E4H2
X1-D		TERMINAL, STUD-GROUND: AB396-1; (12615)	EA	REF											A8A6E1E5
X1-D		SCREW, MACHINE: P343-0298-000; (77250)	EA	1											A8A6E1E5H1
X1-D		WASHER, SPRING TENSION: 310-0074-000; (79807)	EA	1											A8A6EIE5H2
X1-D		TERMINAL, STUD-GROUND AB396-1; (12615)	EA	REF											A8A6L1E6
X1-D		SCREW, MACHINE: P34-3-0298-000; (77250)	EA	1											A8A6E1E6H1
X1-D		WASHER, SPRING TENSION: 310-007-400; (79807)	EA	1											A8A6E1E6H2
X1-D		TRANSISTOR: 2N703; (07688)	EA	3											A8A6E1E6H2
X1-D		TRANSISTOR: 2N703; (07688)	EA	REF									3-52		A8A6E1Q8
X1-D		TRANSISTOR: 2N703; (07688)	EA	REF									3-52		A8A6E1Q9
P--D	5340-157-7860	MOUNT, RESILIENT-BASE; 549-1545-003, (13499)	EA	1							*	*			A8A6MP3
P-H-T	5821-019-6291	OSCILLATOR, RADIO FREQUENCY: 549-1680-004, (13499)	EA	1				*	*	*	*	*	3-52		A8A6L2
X1-D		BOARD, TERMINAL-PRESSED: 549-1682-004; (13499)	EA	1									3-52		A8A6E2TB1
X1-D		CAPACITOR, FIXED, MICA: 805-014X5V0103Z; (72982)	EA	1									3-52		A8A6L2C11
X1-D		CAPACITOR, FIXED, MICA: CM05FD101J03; (81349)	EA	2									3-52		A8A6E2C6
X1-D		CAPACITOR, FIXED, MICA: CM05FD101J03; (81349)	EA	REF									3-52		A8A6E2C7
X1-D		CAPACITOR, FIXED, MICA: DM15F511J300WV4CR; (72136)	EA	2									3-52		A8A6E2C2
X1-D		CAPACITOR, FIXED, MICA: DM15F511J300WV4CR; (72136)	EA	REF									3-52		A8A6E2C4
X1-D		CAPACITOR, FIXED, MICA: 1115E102J0100WV4CR; (72136)	EA	4									3-52		A8A6E2C3
X1-D		CAPACITOR, FIXED, MICA: DM15E102J0100WV4CR; (72136)	EA	REF									3-52		A8A6E2C5
X1-D		CAPACITOR, FIXED, MICA: DM15E102J0100WV4CR; (72136)	EAR	REF									3-52		A8A6E2C8

SECTION II

TM 11-5820-509-35

****REPAIR PARTS FOR DIRECT SUPPORT, GENERAL SUPPORT, AND DEPOT MAINTENANCE (Continued)****															
(1) SMR CODE	(2) FEDERAL STOCK NUMBER	(3) DESCRIPTION Reference Number & Mfr. Code Usable on Code		(4) UNIT OF MEAS	(5) 30 DAY DS MAINTENANCE QTY INC IN UNIT	(6) 30 DAY GS MAINTENANCE ALLOWANCE			(7) 1 YR ALW ALLOWANCE			(8) DEPOT MAINT PER 100 EQUIP CNTGCTY	(9) ALW PER 100 EQUIP	(10) ILLUSTRATION	
						(a) 1-20	(b) 21-50	(c) 51-100	(a) 1-20	(b) 21-50	(c) 51-100			(a) FIG NO.	(b) ITEM NO.
X1-D		CAPACITOR, FIXED, MTICA DM15EIO2JO-ocWv4CR, (72136)		EA	REF									3-52	A8A6E2C10
X1-D		CAPACITOR, FIXED, MICA CM05CDOI0D03, (81349)		EA	2									3-52	A8A6E2C9 *
X1-D		CAPACITOR, FIXED, MICA CM04CDOI0D03, (81349)		EA	REF										A8A6E2C13*
X1-D		CAPACITOR, FIXED, MICA DMIOC020D0, (14655)		EA	2									3-52	A8A6E2C9*
X1-D		CAPACITOR, FIXED, MICA. DMTOCO20D0, (14655)		EA	REF										A8A6E2C13*
X1-D		CAPACITOR, FIXED, MTCA DHIOC030D0, (14655)		EA	2									3-52	A8A6E2C9.*
X1-D		CAPACITOR, FIXED, MECA DMOCO30D0, (14655)		'A	REF										A8A6E2C13*
X1-D		CAPACITOR, FIXED, MICA CM(4CD050D03; (81349)		EA	2									3-52	A8A6E2C9 *
X1-D		CAPACITOR, FIXED, MICA' CMO4CDO50D03, (81349)		EA	REF										A8A6E2C13*
X1-D		CAPACITOR, FIXED, MTCA. CMD4CD100D03, (81349)		LA	2									3-52	A8A6E2C9 *
X1-D		CAPACITOR, FIXED, MICA CM04CDIO0D03, (81349)		EA	REF										A8A6E2C13*
X1-D		CAPACITOR, FIXED, MICA CM04CD120J03, (81349)		EA	2									3-52	A8A6E2C9 *
X1-D		CAPACITOR, FIXED, MICA CMD4CD120J03, (81349)		EA	REF										A8A6E2C13*
X1-D		CAPACITOR, FIXED, MICA- CM04CD150J03, (81349)		EA	2									3-52	A8A6E2C9*
X1-D		CAPACITOR, FIXED, MICA CM04DCD150J03, (81349)		EA	E										A8A6E2C13*
XI-D		CAPACTTOR, FIXED, MTICA DM1OC022D03, (72136)		EA	2									3-52	A8A6E2C9 *
X1-D		CAPACITOR, FIXED, MICA DMIOC022DW3, (72136)		EA	REF										A8A6E2C13*
X1-D		CAPACITOR, FIXED, MTCA- DMIOC024D03, (72136)		EA	2									3-52	A8A6E2C9*
X1-D		CAPACITOR, FIXED, MTCA DMIOC024D03, (72136)		EA	REF										A8A6E2C13*
X1-D		CAPACITOR, FIXED, MICA DMIOC027D03, (72136)		EA	2									3-52	A8A6E2C9*
X1-D		CAPACITOR, FIXED, MTICA. DMOC027D03, (72136)		EA	REF										A8A6E2C13*
X1-D		CAPACITOR, FIXED, MICA DM1OCO33D03, (72136)		EA	2									3-52	A8A6E2C9*
X1-D		CAPACITOR, FIXED, MICA. DMOC033D03, (72136)		EA	REF										A8A6E2C13*
XI-D		CAPACITOR, FIXED, MICA DMIOC036D03, (72136)		EA	2									3-52	A8A6E2C9*
X1-D		CAPACITOR, FIXED, MICA DM1OC036D03, (72136)		EA	REF										A8A6E2C13*

* SELECT PER OPERATIONAL REQUIREMENT.

SECTION II

TM 11-5820-509-35

****REPAIR PARTS FOR DIRECT SUPPORT, GENERAL SUPPORT, AND DEPOT MAINTENANCE (Continued)****															
(1) SMR CODE	(2) FEDERAL STOCK NUMBER	(3) DESCRIPTION Reference Number & Mfr. Code Usable on Code		(4) UNIT OF MEAS	(5) QTY INC IN UNIT	(6) 30 DAY DS MAINTENANCE ALLOWANCE			(7) 30 DAY GS MAINTENANCE ALLOWANCE			(8) 1 YR ALW PER 100 EQUIP CNTGCTY	(9) DEPOT MAINT ALW PER 100 EQUIP	(10) ILLUSTRATION	
						(a) 1-20	(b) 21-50	(c) 51-100	(a) 1-20	(b) 21-50	(c) 51-100			(a) FIG NO.	(b) ITEM NO. OR REFERENCE DESIGNATION
X1-D		CAPACITOR, FIXED, MICA' DMIOC039D03, (72136)		EA	2									3-52	A8A6E2C9 *
X1-D		CAPACITOR, FIXED, MICA DMIOC039D03; (72136)		EA	REF										A8A6E2C13 *
X1-D		CAPACITOR, FIXED, MICA. EMIOCO43D03, (72136)		MA	2									3-52	A8A6Z2C9 8
X1-D		CAPACITOR, FIXED, MICA DMiOCOh3D03; (72136)		EA	REF										A8A6E2C13 *
X1-D		CAPACITOR, FIXED, MICA: DMOC047D03; (72136)		EA	2									3-52	A8A62C9 *
X1-D		CAPACITOR, FIXED, MICA DM1OC0o7D03, (72136)		EA	REF										A8A6E2C13 *
X1-D		CAPACITOR, FIXED, MICA. DMIOCO56D03; (72136)		EA	2									3-52	A8A6Z2C9 *
X1-D		CAPACITOR, FIXED, MICA: DItOC056D03, (72136)		EA	REF										A8A6E2C13 *
X1-D		CAPACITOR, FIXED, MICA- Dmoco66D03, (72136)		EA	2									3-52	A8A6Z2C9 8 *
X1-D		CAPACITOR, FIXED, MICA DMioco66D03, (72136)		EA	REF										A8F6E2C13 *
X1-D		CAPACITOR, FIXED, MICA- MT1oCo68D03, (72136)		EA	2									3-52	AA62C9 *
X1-D		CAPACITOR, FIXED, MTCA- DMOC068D03; (72136)		EA	REF										AaA6f2C13 8
X1-D		CAPACITOR, FIXED, MTCA: DMIOC075D03; (72136)		EA	2									3-52	A8A6Z2C9 *
X1-D		CAPACITOR, FIXED, MICA- DMiOC075D03, (72136)		A	REF										A8A6E2C13 *
X1-D		CAPACITOR, FIXED, MICA- DMIOC082D03, (72136)		EA	2									3-52	A8A6E2C9 *
X1-D		CAPACITOR, FIXED, MICA. DM10Co82D03, (72136)		EA	REF										A8A6E2C13 *
X1-D		CAPACITOR, FIXED, MICA: DMTOCO91D03; (72136)		EA	2									3-52	A8A6E2C9 *
X1-D		CAPACITOR, FIXED, MICA- DMIOCO91D03; (72136)		EA	RF										A8A6E2C13 *
X1-D		CAPACITOR, VARIABLE, GLASS 682268, (19644)		EA	1									3-52	A8A6E2C1
X1-D		CAPACITOR, VOLTAGE, VARIABLE: hN4795B, (01281)		EA	1									3-52	A8A6E2C12
X1-D		COIL, RADIO FREQUENCY- LTIOK003; (81349)		EA	1									3-52	AaA6E2LI
X1-D		COIL, RADIO FREQUENCY: LTIOK029, (81349)		EA	1									3-52	A8A6Z2L2
X1-D		OSCILLATOR, SUBASSEMBLY 756-7606-003, (13499)		EA	1									3-52	A8A6E2AI
XI-D		RESISTOR, FIXED, CDNPOSITION RCR07G221KS, (81349)		EA	1									3-52	A8A6E2R17
X1-D		RESISTOR, FIXED, COMPOSITION. RCR07G56iKS, (813h9)		EA	1									3-52	A8A6E2R13
* SELECT PER OPERATIONAL REQUIREMENT.															

SECTION II

TM 11-5820-509-35

****REPAIR PARTS FOR DIRECT SUPPORT, GENERAL SUPPORT, AND DEPOT MAINTENANCE (Continued)****															
(1) SMR CODE	(2) FEDERAL STOCK NUMBER	(3) DESCRIPTION Reference Number & Mfr. Code Usable on Code		(4) UNIT OF MEAS	(5) QTY INC IN UNIT	(6) 30 DAY DS MAINTENANCE ALLOWANCE			(7) 30 DAY GS MAINTENANCE ALLOWANCE			(8) 1 YR ALW PER 100 EQUIP CNTGCT	(9) DEPOT MAINT ALW PER 100 EQUIP	(10) ILLUSTRATION	
						(a) 1-20	(b) 21-50	(c) 51-100	(a) 1-20	(b) 21-50	(c) 51-100			(a) FIG NO.	(b) ITEM NO. OR REFERENCE DESIGNATION
X1-D		RESISTOR, FIXED, COMPOSITION RCR07G222KS, (81349)		EA	1									3-52	A8A6E2R16
X1-D		RESISTOR, FIXED, COMPOSITION RCR07G472MS, (81349)		EA	1									3-52	A8A6E2R12
X1-D		RESISTOR, FIXED, COMPOSITION RCR07GC1003KS, (FP3L49)		EA	L									3-52	A8A6ECR1C
X1-D		RESISTOR, FIXED, COMPOSITION RCR07G103KS, (81349)		EA	REF									3-52	A8A6ERIII
X1-D		RESISTOR, FIXED, COMPOSITION RCR07G103KS, (81349)		EA	REF									3-52	A8A6E2R'L
X1-D		RESISTOR, FIXED, COMPOSITION RCR07C1003KS, (81349)		EA	REF									3-52	A8A6E2R15
X1-D		RESISTOR, FIXED, COMPOSITION RCRO7Gh7hKS, (81349)		EA	2									3-52	A8A6E2R5
X1-D		RESISTOR, FIXED, COMPOSITION RCRO7G474KS, (81349)		EA	REF									3-52	A8A6E2R6
X1-D		RESISTOR, FIXED, COMPOSITION RN60D3830F, (81349)		EA	1									3-52	A8A6E2R18 *
X1-D		RESISTOR, FIXED, FILM RN60D4220F, (81349)		EA	1									3-52	A8A6E2R18 "
X1-D		RESISTOR, FIXED, FILM RN60D6L40F, (81349)		EA	1									3-52	A8A6E2R18 '
X1-D		RESISTOR, FIXED, FILM RN60D5110F, (81349)		EA	1									3-52	A8A6E2R18 -
X1-D		RSISTOR, FIXED, FILM RN60D5620F, (81349)		EA	1									3-52	A8A6E2R18 *
X1-D		RESISTOR, FIXED, FILM RN60DD102F, (81349)		EA	2									3-52	A8A6E2R7
X1-D		RESISTOR, FIXED, FILM RN60D1002F, (81349)		EA	REF									3-52	A8A6E2R8
X1-D		RESISTOR, FIXED, FILM: RP60D2152F, (81349)		EA	1									3-52	A8A6E2R9
X1-D		RESISTOR, FIXED, FILM RF60D6813F, (81349)		EA	1									3-52	A8A6E2Rb4
X1-D		RESISTOR, FIXED, FILM RN60D9093F, (81349)		EA	1									3-52	A8A6E2RL *
X1-D		RESISTOR, FIXED, FILM RN65D1L74F, (81349)		EA	1									3-52	A8A6E2R4 *
X1-D		RESISTOR, FIXED, FILM RN65D1964F, (81349)		EA	1									3-52	A8A6E2Rb -
X1-D		RESISTOR, VARIABLE, COMPOSITION 3051P1-105, (80294)		EA	1									3-52	A8A6E2R1
X1-D		NUT, SELF-LOCKING, HEXAGON 68-1660-26, (72962)		EA	2										A8A6E2R1H1
X1-D		NUT, SELF-LOCKING, HEXAGON 68-1660-26, (72962)		EA	REF										A8A6E2R1H2
X1-D		SCREW, MACHINE P343-0301-000, (77250)		EA	2										A8A6E2R1H3
X1-D		SCREW, MACHINE P343-0301-000, (77250)		EA	REF										A8A6E2R1H4
		* SELECT PER OPERATIONAL REQUIREMENT													

****REPAIR PARTS FOR DIRECT SUPPORT, GENERAL SUPPORT, AND DEPOT MAINTENANCE (continued)****															
(1) SMR CODE	(2) FEDERAL STOCK NUMBER	(3) DESCRIPTION Reference Number & Mfr. Code Usable on Code		(4) UNIT OF MEAS	(5) QTY INC IN UNIT	(6) 30 DAY DS MAINTENANCE ALLOWANCE			(7) 30 DAY GS MAINTENANCE ALLOWANCE			(8) 1 YR ALW PER 100 EQUIP CNTGCT	(9) DEPOT MAINT ALW PER 100 EQUIP	(10) ILLUSTRATION	
						(a) 1-20	(b) 21-50	(c) 51-100	(a) 1-20	(b) 21-50	(c) 51-100			(a) FIG NO.	(b) ITEM NO. OR REFERENCE DESIGNATION
XI-D		RESISTOR, VARIABLE, WIRE WOUND. 224P1-503, (80294)		EA	2									3-52	A8A6E2R2
X1-D		NUT, SELF-LOCKING, HEXAGON. 68-1660-26; (72962)		EA	2										A8A6E2R2H1
XI-D		NUT, SELF-LOCKING, HEXAGON: 68-1660-26; (72962)		EA	REF										A8A6E2R2H2
X1-D		SCREW, MACHINE: P343-0361-000, (77250)		EA	2										A8A6E2R2H3
X1-D		SCREW, MACHINE. P343-0361-000; (77250)		EA	RKF										A8A6E2RH4
X1-D		RESISTOR, VARIABLE, WRE WOUND: 224P1-503; (80294)		EA	REF										A8A6E2R3
X1-D		SEMICONDUCTOR DEVICE, DIODE: 111821A; (87688)		EA	2								3-52	A8A6E2CRI	
XI-D		SEMICONDUCTOR DEVICE, DIODE: 111821A, (07688)		EA	REF								3-52	A8A6E2CR2	
X1-D		TRANSISTOR: 21703; (07688)		EA	3								3-52	A8A6E2Q1	
X1-D		TRAIISISTOR: 2r703; (o7688)		EA	REF								3-52	A8A6E2q2	
X1-D		TRANSISTOR 2w703; (07688)		EA	REF								3-52	A8A6E2Q3	
P-H-T	5820-087-3440	OSCILLATOR SUBASSEMBLY, FRAME 549-1552-00o, (13499)		EA	1				*	*	*	*	*	3-13	A8A6Ai
P-D	5910-9h5-0313	CAPACITOR, FIXED, CERAMIC: CK13AX222M, (81349)		EA	1							*	*	3-53	A8A6AIC22
P-D	5910-102-1346	CAPACITOR, FIXED, CERAMIC: CK12BX472K; (81349)		EA	3							*	*	3-53	A8A6AIC18
P-D	5910-102-1346	CAPACITOR, FIXED, CERAIIIC: CK12BX472K; (81349)		EA	REF							REF	REF	3-53	A8A6A1C23
P-D	5910-102-1346	CAPACITOR, FIXED, CERAMIC: CK12BX472K; (81349)		EA	REF							REF	REF	3-53	A8A6A1C26
P-D	5910-726-5003	CAPACITOR, FIXED, ELECTROLYTIC: 150D10SXO35A2, (56289)		EA	2							REF	REF	3-53	A8A6AiC36
P-D	5910-726-5003	CAPACITOR, FIXED, ELECTROLYTIC 150D105XOO35A2, (56289)		EA	REF							REF	REF	3-53	A8A6AiC39
P-D	5910-901-6105	CAPACITOR, FIXED, FILM 192P4729R8, (56289)		EA	2							*	*	3-53	A8A6AIC15
P-D	5910-901-6105	CAPACITOR, FIXED, FILM. 192P4729R8; (56289)		EA	REF							REF	REF	3-53	A8A6AIC16
P-D	5910-844-0905	CAPACITOR, FIXED, MICA: CM05FDIOJ03, (81349)		EA	2							REF	RFF	3-53	A8A6AIC17
P-D	5910-844-0905	CAPACITOR, FIXED, MICA: C05FD101J03; (81349)		EA	REF							REF	REF	3-5-	A8A6AIC19
P-D	5910-460-0869	CAPACITOR, FIXED, MICA: CM05FD221J03, (81349)		EA	1							REF	REF	3-53	A8A6AiC40
P-D		CAPACITOR, FIXED, MICA DM15F511J300W4CR, (72136)		EA	2							REF	REF	3-53	A8A6A1C13
P-D		CAPACITOR, FIXED, MICA DM15F511J300WV4CR, (72136)		EA	REF							REF	REF	3-53	A8A6A1C21

SECTION II

TM 11-5820-509-35

****REPAIR PARTS FOR DIRECT SUPPORT, GENERAL SUPPORT, AND DEPOT MAINTENANCE (continued)****															
(1) SMR CODE	(2) FEDERAL STOCK NUMBER	(3) DESCRIPTION Reference Number & Mfr. Code Usable on Code		(4) UNIT OF MEAS	(5) QTY INC IN UNIT	(6) 30 DAY DS MAINTENANCE ALLOWANCE			(7) 30 DAY GS MAINTENANCE ALLOWANCE			(8) 1 YR ALW PER 100 EQUIP CNTGCT	(9) DEPOT MAINT ALW PER 100 EQUIP	(10) ILLUSTRATION	
						(a) 1-20	(b) 21-50	(c) 51-100	(a) 1-20	(b) 21-50	(c) 51-100			(a) FIG NO.	(b) ITEM NO. OR REFERENCE DESIGNATION
P-D	5910-903-6144	CAPACITOR, FIXED, MIICA CMO6FD162Jo3, (81349)		EA	1							*	*	3-53	A8A6AIC24
M-D	CHASSIS, ELECT	TRICAL EQUIPMENT 549-1555-005, (13499)		EA	1									3-53	A8AbALAI
P-D	5935-806-2688	JACK, TIP 72-140-1, (12615)		EA	1							*	*	3-2	A8A6AIAIJ1
P-D	5935-432-6472	JACK, TIP, 72-1140-2, (12615)		EA	1							*	*	3-12	A8A6AIA1J2
P-D	5935-432-6473	JACK, TIP. 72-140-3, (12615)		EA	1							*	*	3-53	A8A6AIAIJ3
P-D	5935-432-474	JACK, TIP- 72-140-4, (12615)		EA	1							*	*	3-53	A8A6AIA1J4
P-D	5950-828-1336	COIL, RADIO FREQUENCY LTIOK010, (81349)		EA	1							*	*	3-53	A8A6ALL5
P-D	5950-994-6600	COIL, RADIO FREQUENCY LT1OK020, (81349)		EA	1							REF	REF	3-53	A8A6A1L3
P-D	5950-893-8650	COIL, RADIO FREQUENCY- LTIOK036, (81349)		EA	1							*	*	3-53	A8A6A1L4
P-D	5950-070-7641	COIL, RADIO FREQUENCY LTIOK060, (81349)		EA	1							REF	REF	3-53	ASA6A1L6
P-D	5325-174-5317	GROC, RUBBER MS14S35489-4, (96906)		EA	4							REF	REF	3-53	A8A6AIHI
P-D	5325-174-5317	GROHMET, RUBBER MS35489-4, (96906)		EA	REF							REF	REF	3-53	A8A6AH2
P-D	5325-174-5317	GR ONET, RUBBER NS35489-4, (96906)		EA	REF							REF	REF	3-53	A8A6AIH3
P-D	5325-174-5317	GROHMET, RUBBER- NS 35489-4, (96906)		EA	REF							REF	REF		A8A6AIH4
P-D	5905-825-2360	RESISTOR, FIXED, CCMPOSITION RCR07G221KS, (81349)		EA	1							REF	REF	3-53	A8A6AiR45
P-D		RESISTOR, FIXED, CPOSITION- RCR07G222KS, (81349)		EA	1							REF	REF	3-53	A8A6AiR29
P-D		RESISTOR, FIXED, COMPOSITION: RCR07G272KS, (81349)		EA	1							REF	REF	3-53	A8A6AiR25
P-D		RESISTOR, FIXED, COHPOSITION. RCR07G332KS, (81349)		EA	2							*	*	3-53	A8A6A1R24
P-D		RESISTOR, FIXED, COMPOSITION RCR07G332KS, (81349)		EA	REF							REF	REF	3-53	A8A6AiR33
P-D		RESISTOR, FIXED, COMPOSITION: RCR07c472KS; (81349)		EA	2							REF	REF	3-53	A8A6A1R26
P-D		RESISTOR PIXED, COMPOSITION RCR764,72KS, (81349)		EA	REF							REF	REF	3-53	A8A6A1R27
P-D	5905-816-8554	RESISTOR, FIXED, CCMPOSITION RCR07G103KS, (8139)		EA	4							REF	REF	3-53	A8A6A1R23
P-D	5905-816-8554	RESISTOR, FIXED, COMPOSITION RCR07GI03KS, (81349)		EA	REF							REF	REF	3-53	A8A6A1R28
P-D	5905-816-8554	RESISTOR, FIXED, CC4POSITION: RCR07G103KS, (81349)		EA	REF							REF	REF	3-53	A8A6AiR31
P-D	5905-816-8554	RESISTOR, FIXED, COKPOSITION. RCR07G103KS, (81349)		EA	REF							REF	REF	3-53	A8A6A1R32

SECTION II

TM 11-5820-509-35

****REPAIR PARTS FOR DIRECT SUPPORT, GENERAL SUPPORT, AND DEPOT MAINTENANCE (continued)****															
(1) SMR CODE	(2) FEDERAL STOCK NUMBER	(3) DESCRIPTION Reference Number & Mfr. Code Usable on Code		(4) UNIT OF MEAS	(5) QTY INC IN UNIT	(6) 30 DAY DS MAINTENANCE ALLOWANCE			(7) 30 DAY GS MAINTENANCE ALLOWANCE			(8) 1 YR ALW PER 100 EQUIP CNTGCTY	(9) DEPOT MAINT ALW PER 100 EQUIP	(10) ILLUSTRATION	
						(a) 1-20	(b) 21-50	(c) 51-100	(a) 1-20	(b) 21-50	(c) 51-100			(a) FIG NO.	(b) ITEM NO. OR REFERENCE DESIGNATION
P-D	5910-702-3517	TERMIAl, STUD-GROUND. AB396-1; (12615)		EA	5							*	*		A8A6A1E1
P-D		SCREW, MACHINE P343-298-000, (77250)		EA	1							*	*		A8A6A1iEH1
P-D	5310-981-2255	WASHER, SPRING TENSION. 310-0074-000, (79807)		EA	1							REF	REF		A8A6A1EIH2
P-D	5940-702-3517	TERMIAl, STUD-GROUND: AB396-i, (12615)		EA	REF							REF	REF		A8A6A1E2
P-D		SCREW, MACHINE P343-0298-000, (77250)		EA	1							REF	REF		A8A6E2li
P-D	5310-981-2255	WASHER, SPRING TENSION 310-0074-000; (79807)		EA	1							REF	REF		A8A6A1E2H2
P-D	5940-702-3517	TERMIAl, STUD-GROUND AB396-1, (12615)		EA	REF							REF	REF		A8A6AIE3
P-D		SCREW, MACHINE- P343-0829-00, (77250)		EA	1							REF	REF		AAK6AIE3N1
P-D	5310-981-2255	WASHER, SPRING TENSION 310-0074-000, (79807)		EA	1							REF	REF		A8A6AIE3H2
P-D	5940-702-3517	TERMIAl, STUD-GROUND AB396-1, (12615)		EA	REF							REF	REF		AaA6A1E4
P-D		SCREW, MACHINE- P3h3-0298-000, (77250)		EA	1							REF	REF		ABA6AIEbH1
P-D	5310-981-2255	WASHER, SPRING TENSION. 310-0074-000; (79807)		EA	1							REF	REF		A8A6AE4H2
P-D	5940-702-3517	TERMIAl, STUD-GROUD AB39-1; (12615)		EA	REF							REF	REF		A8A6A1E5
P-D		SCREW, MACHINE P343-0298-000, (77250)		EA	1							REF	REF		A8A6A1ESHI
P-D	5310-981-2255	WASHER, SPRING TENSION 310-0074-000; (79807)		EA	1							REF	REF		A&A6A1ESH2
P-D		TRANSISTOR- 2N703; (07688)		EA	3							REF	REF	3-53	A8A6A1Qh
P-D		TRANSISTOR 2N7D03, (07688)		EA	REF							REF	REF	3-53	A8A6A1Q5
P-D		TRANSISTOR. 2N703, (07688)		EA	REF							REF	REF	3-53	A8A6A1Q6
P-D		RESISTOR, FIXED, COMPOSITION RCR07G272KS; (81349)		EA	3							REF	REF	3-53	ABA6R30 *
P-D		RESISTOR, FIXED, COMPOSITION RCRO7G272KS, (813b9)		EA	PEPF							REF	REF		A8A6R45 *
P-D		RESISTOR, FIXED, COMPOSITION RCR07G272KS; (813h9)		EA	REF							REF	REF		ABA6R46 *
P-D		RESISTOR, FIXED, COWMOSITION RCRO7G332KS; (81349)		EA	3							REF	REF		A8A6R30 *
P-D		RESISTOR, FIXED, COMPOSITION RCRo7G332XS; (813b9)		EA	REF							REF	REF		A83A6R45 *
P-D		RESISTOR, FIXED, COMPOSITION RCRO7G332KS, (813L9)		EA	REF							REF	REF		A8A6R46 *
P-D		RESISTOR, FIXED, COMPOSITION RCRB7G392KS; (81349)		EA	3							REF	REF		A8A6R30 *

* SELECT PER OPERATIONAL REQUIREMENT.

****REPAIR PARTS FOR DIRECT SUPPORT, GENERAL SUPPORT, AND DEPOT MAINTENANCE (continued)****															
(1) SMR CODE	(2) FEDERAL STOCK NUMBER	(3) DESCRIPTION Reference Number & Mfr. Code Usable on Code		(4) UNIT OF MEAS	(5) QTY INC IN UNIT	(6) 30 DAY DS MAINTENANCE ALLOWANCE			(7) 30 DAY GS MAINTENANCE ALLOWANCE			(8) 1 YR ALW PER 100 EQUIP CNTGCTY	(9) DEPOT MAINT ALW PER 100 EQUIP	(10) ILLUSTRATION	
						(a)	(b)	(c)	(a)	(b)	(c)			(a) FIG NO.	(b) ITEM NO. OR REFERENCE DESIGNATION
						1-20	21-50	51-100	1-20	21-50	51-100				
P-D	5905-070-9391	RESISTOR, FIXED, COMPOSITION RCRO7G392KS, (81349)		EA	REF							REF	REF		A8A6R45 *
P-D	5905-070-9391	RESISTOR., FIXED, COMPOSITION: RCRO7G392KS, (81349)		EA	REF							REF	REF		A8A6R46 *
P-D	5905-752-3340	RESISTOR, FIXED, COMPOSITION. RCRO7G472KS, (81349)		EA	3							REF	REF		A8A6R0 *
P-D	5905-752-3340	RESISTOR, FIXED, COMPOSITION RCRO7G472KS; (81349)		EA	REF							REF	REF		A8A6R5 *
P-D	5905-752-3340	RESISTOR, FIXED, COMPOSITION. RCRO7C472KS, (81349)		EA	REF							REF	REF		A8A6R46 *
P-D	5905-070-9392	RESISTOR, FIXED, COMPOSITION. RCRO7G562KS, (81349)		EA	3							REF	REF		A8A6R30 *
P-D	5905-070-9392	RESISTOR, FIXED, COMPOSITION- RCRO7G562KS, (81349)		EA	REF							REF	REF		A8A6RS5 *
P-D	5905-070-9392	RESISTOR, FIXED, COMPOSITION- RCRO7G562KS, (81349)		EA	REF							REF	REF		A8A6R46 *
P-D		RESISTOR, FXED, COMPOSITION- RCRo7C682KS, (81349)		EA	3							*	*		A8A6R30 *
P-D		RESISTOR, FIXED, COMPOSITIOD: RCRO7G682Ks, (81349)		EA	REF							REF	REF		A8A6Rb45 *
P-D		RESISTOR, FIXED, COMPOSITIOD- RCRO7G682Ks, (81349)		EA	REF							REF	REF		A8A6R46 *
P-D	5905-834-9874	RESISTOR, FIXED, COMPOSITION RCRO7C822Ks, (81349)		EA	3							REF	REF		A8A6R30 *
P-D	5905-834-9874	RESISTOR, FIXED, COMPOSITION RCR7CG822KS, (81349)		EA	REF							REF	REF		A8A6R45 *
P-D	5905-834-9874	RESISTOR, FIXED, COMPOSITION. RCRo7c822Ks, (81349)		EA	REF							REF	REF		A8A6R46 *
P-D	5905-816-8554	RESISTOR, FIXED, COMPOSITION- RCRo7GIO3Ks; (81349)		EA	3							REF	REF		A8A6R30 *
P-D	5905-816-8554	RESISTOR, FIXED, COMPOSITION' RCRO7GC103KS, (813b9)		EA	REF							REF	REF		A8A6R4S *
P-D	5905-816-8554	RESISTOR, FIXED, COMPOSITION- RCRO7G103KS, (81349)		EA	REF							REF	REF		A8A6R46 *
P-D		RESISTOR, FIXED, COMPOSITION RCRO7G123KS, (81349)		EA	3							REF	REF		A8A6R30 *
P-D		RESISTOR, FIXED, COMPOSITION- RCRO7G123KS, (81349)		EA	REF							REF	REF		A8A6Rb5 *
P-D		RESISTOR, FIXED, COMPOSITION RCRO7123KS, (81349)		EA	REF							REF	REF		A8A6R46 *
P-D		RESISTOR, FIXED, COMPOSITION' RCR7GC153KS, (81349)		EA,	3							*	*		A8A6R30 *
P-D		RESISTOR, FTXED, COMPOSITION. RCRO7G153KS, (81349)		EA	REF							REF	REF		A8A6R45 *
P-D		RESISTOR, FIXED, COMPOSITION RCRO7G153KS, (81349)		EA	REF							REF	REF		A8A6Rb6 *
P-D		RESISTOR, FIXED, COMPOSITION RCRO7G183KS; (81349)		EA	3							REF	REF		A8A6R30 *
P-D		RESISTOR, FIXED, COMPOSITION RCRO7G183KS, (81349)		EA	REF							*	*		ASA6R4S *

* SELECT PER OPERATIONAL REQUIREMENT.

****REPAIR PARTS FOR DIRECT SUPPORT, GENERAL SUPPORT, AND DEPOT MAINTENANCE (continued)****															
(1) SMR CODE	(2) FEDERAL STOCK NUMBER	(3) DESCRIPTION Reference Number & Mfr. Code Usable on Code		(4) UNIT OF MEAS	(5) QTY INC IN UNIT	(6) 30 DAY DS MAINTENANCE ALLOWANCE			(7) 30 DAY GS MAINTENANCE ALLOWANCE			(8) 1 YR ALW PER 100 EQUIP CNTGCTY	(9) DEPOT MAINT ALW PER 100 EQUIP	(10) ILLUSTRATION	
						(a)	(b)	(c)	(a)	(b)	(c)			(a) FIG NO.	(b) ITEM NO. OR REFERENCE DESIGNATION
						1-20	21-50	51-100	1-20	21-50	51-100				
P-D	5905-838-6599	RESISTOR, FIXED, COMPOSITION RCR07G183KS, (81349)		EA	REF							REF	REF		A8A6R46 *
P-D	5905-824-1729	RESISTOR, FIXED, COMPOSITION RCR07G223KS, (813L9)		EA	3							REF	REF		A8A6R30 *
P-D	5905-824-1729	RESISTOR, FIXED, COMPOSITION RCR07G223KS, (81349)		EA	REF							REF	REF		A8A6RB5 *
P-D	5905-824-1729	RESISTOR, FIXED, COMPOSITION. RCR07G223KS, (81349)		EA	REF							REF	REF		A8A6R46 *
P-D		RESISTOR, FIXED, COMPOSITION: RCR07G273KS, (81349)		EA	3							REF	REF		A8A6R30 *
P-D		RESISTOR, FIXED, COMPOSITION. RCR07G273KS, (81349)		EA	REF							REF	REF		A8A6R45 *
P-D		RESISTOR, FIXED, COMPOSITION RCR07G273KS, (81349)		EA	REF							REF	REF		A8A6R46 *
P-D	5940-702-3517	TERMINAL, STUD-GROUND AB396-1, (12615)		EA	1							REF	REF		A8A6E3
P-H-S	5820-960-7845	TRANSLATOR, SIGNAL DATA: CV1377APRC47, (80058)		EA	1				*	*	*	*	*	3-4	A8A3
P-H-T	5820-975-5432	AMPLIFIER, RADIO FREQUENCY 549-5984-003, (13499)		EA	1				*	*	*	*	*	3-10	A8A3E46
P-D	5305-054-5636	SCREW, MACHINE MS51957-2; (96906)		EA	2							REF	REF		A8A3E46H2
X1-D		BOARD, PRINTED CIRCUIT. 549-5982-003, (13499)		EA	1									3-37	A8A3E46E1
X1-D		COIL, RADIO FREQUENCY- 4422-11-117; (82142)		EA	1									3-37	A8A3E46L102
X1-D		CAPACITOR, FIXED, CERAMIC CK14BX223M, (81349)		EA	2									3-37	A8A3E46C276
X1-D		CAPACITOR, FIXED, CERAMIC: CK14BX223M; (81349)		EA	REF									3-37	A8A3E46C281
X1-D		CAPACITOR, FIXED, CERAMIC: 6s8o83, (56289)		EA	4									3-37	A8A3E46C247
X1-D		CAPACITOR, FIXED, CERAMIC. 6S8083, (56289)		EA	REF									3-37	A8A3E46C269
X1-D		CAPACITOR, FIXED, CERAMIC: 6S8083, (56289)		EA	REF									3-37	A8A3E46C272
X1-D		CAPACITOR, FIXED, CERAMIC- 6S8083, (56289)		EA	REF									3-37	A8A3E46c275
X1-D		CAPACITOR, FIXED, MICA CMDSCDOSD0W3; (81349)		EA	1									3-37	A8A3E46C280
X1-D		CAPACITOR, FIXED, MICA. CMJ5FDIO1JO3, (81349)		EA	3									3-37	A8A3Eh6C246
X1-D		CAPACITOR, FIXED, MICA- CMDSFDIO1JO3, (81349)		EA	REF									3-37	A8A3E46C268
X1-D		CAPACITOR, FIXED, MICA- CM5FD101JO3, (81349)		EA	REF									3-37	A8A3E46C271
X1-D		CAPACIT6R, FIXED, MICA CM05DFD181JO3, (81349)		EA	2									3-37	A8A3E46C270
X1-D		CAPACITOR, FIXED, MICA CM05FD181JO3, (81349)		EA	REF									3-37	A8A3E46C273

* SELECT PER OPERATIONAL REQUIREMENT.

SECTION II

TM 11-5820-509-35

****REPAIR PARTS FOR DIRECT SUPPORT, GENERAL SUPPORT, AND DEPOT MAINTENANCE (continued)****															
(1) SMR CODE	(2) FEDERAL STOCK NUMBER	(3) DESCRIPTION Reference Number & Mfr. Code Usable on Code		(4) UNIT OF MEAS	(5) QTY INC IN UNIT	(6) 30 DAY DS MAINTENANCE ALLOWANCE			(7) 30 DAY GS MAINTENANCE ALLOWANCE			(8) 1 YR ALW PER 100 EQUIP CNTGCTY	(9) DEPOT MAINT ALW PER 100 EQUIP	(10) ILLUSTRATION	
						(a)	(b)	(c)	(a)	(b)	(c)			(a) FIG NO.	(b) ITEM NO. OR REFERENCE DESIGNATION
						1-20	21-50	51-100	1-20	21-50	51-100				
X1-D		CAPACITOR, FIXED, MICA. DM15F471J300WV4CR, (72136)		EA	1									3-37	A8A3E46C274
X1-D		RESISTOR, FIXED, COMPOSITION RCR07G121KS, (81349)		EA	3									3-37	A8A3E46R125
X1-D		RESISTOR, FIXED, COMPOSITION RCR07G121KS, (81349)		EA	REF									3-37	A8A3E46R130
X1-D		RESISTOR, FIXED, COMPOSITION RCR07G121KS, (81349)		EA	REF									3-37	A8A3E46R135
X1-D		RESISTOR, FIXED, COMPOSITION RCR07CG331KS, (81349)		EA	1									3-37	A8A3E46R134
X1-D		RESISTOR, FIXED, COMPOSITION RCR07GC1002KS, (81349)		EA	6									3-37	A8A3E46R119
X1-D		RESISTOR, FIXED, COMPOSITION RCR07C10cKS, (81349)		EA	REF									3-37	A8A3E462
Xi-D		RESISTOR, FIXED, COMPOSITION RCR07G102KS, (81349)		EA	REF									3-37	A8A3E46R124
X1-D		RESISTOR, FIXED, COMPOSITION RCR07G102KS, (81349)		EA	REF									3-37	A8A3E46R128
X1-D		RESISTOR, FIXED, COMPOSITION RCR07G102KS; (81349)		EA	REF									3-37	A8A3E46R129
X1-D		RESISTOR, FIXED, COMPOSITION RCR07G102KS, (81349)		EA	REF									3-37	A8A3E46R133
X1-D		RESISTOR, FIXED, COMPOSITION RCR07GC153KS; (81349)		EA	1									3-37	A8A3E46R120
X1-D		RESISTOR, FIXED, COMPOSITION. RCR07G223KS, (81349)		EA	2									3-37	A8A3E46R122
X1-D		RESISTOR, FIXED, COMPOSITION RCR07G223KS, (81349)		EA	REF									3-37	A8A3E46R132
X1-D		RESISTOR, FIXED, COMPOSITION- RCR07CG822KS, (81349)		EA	1									3-37	A8A3E46R127
X1-D		RESISTOR, FIXED, COMPOSITION: RCR07G273KS, (81349)		EA	3									3-37	A8A3E46R121
X1-D		RESISTOR, FIXED, COMPOSITION RCR07G273KS, (81349)		EA	RE2									3-37	A8A3E46R126
X1-D		RESISTOR, FIXED, COMPOSITION RCR07C273KS, (81349)		EA	REF									3-37	A8A3E46R131
X1-D		TRANSISTOR 2N703, (07688)		EA	4									3-37	A8A3E46Q16
X1-D		TRANSISTOR 2N703, (07688)		EA	REF									3-37	A8A3E46Q17
X1-D		TRANSISTOR 2N703, (07688)		EA	REF									3-37	A8A3E46Q18
X1-D		TRANSISTOR 2N703, (07688)		EA	REF									3-37	A8A3E46Q19
P-H-T	5820-975-5430	AMPLIFIER, RADIO FREQUENCY 549-5996-oo00, (13499)		EA	1				*	*	*	*	*	3-9	A8A3E47
X1-D		BOARD, PRINTED CIRCUIT 549-5995-004, (13499)		EA	1									3-38	A8A3E47E1
X1-D		CAPACITOR, FIXED, CERAMIC CK14BX223M, (81349)		EA	2									3-38	A8A3E47C144

****REPAIR PARTS FOR DIRECT SUPPORT, GENERAL SUPPORT, AND DEPOT MAINTENANCE (continued)****															
(1) SMR CODE	(2) FEDERAL STOCK NUMBER	(3) DESCRIPTION Reference Number & Mfr. Code Usable on Code		(4) UNIT OF MEAS	(5) QTY INC IN UNIT	(6) 30 DAY DS MAINTENANCE ALLOWANCE			(7) 30 DAY GS MAINTENANCE ALLOWANCE			(8) 1 YR ALW PER 100 EQUIP CNTGCTY	(9) DEPOT MAINT ALW PER 100 EQUIP	(10) ILLUSTRATION	
						(a)	(b)	(c)	(a)	(b)	(c)			(a)	(b)
						1-20	21-50	51-100	1-20	21-50	51-100			FIG NO.	ITEM NO. OR REFERENCE DESIGNATION
X1-D		CAPACITOR, FIXED, CERAMIC CK14BX223M; (81349)		A	REF									3-38	A8A3E47C153
X1-D		CAPACITOR, FIXED, CERAMIC 6S8083, (56289)		EA	13									3-38	A8A3E47C142
X1-D		CAPACITOR, FIXED, CERLMIC- 6S8083, (56289)		EA	REF									3-38	A8A3E47C143
X1-D		CAPACITOR, FIXED, CERAMIC: 6S8o83, (56289)		EA	REF									3-38	A8A3E47C150
X1-D		CAPACITOR, FIXED, CERAMIC: 6S8083, (56289)		EA	REF									3-38	A8A3Eh7C151
X1-D		CAPACITOR, FIXED, CERAMIC. 6S8083, (56289)		EA	REF									3-38	A8A3E47C154
X1-D		CAPACITOR, FIXED, CERAMIC. 6S8083; (56289)		EA	REF									3-38	A8A3E47C156
X1-D		CAPACITOR, FIXED, CERAMC- 6S8083, (56289)		EA	REF									3-38	A8A3E47C158
X1-D		CAPACITOR, FIXED, CERAMIC 6S8083, (56289)		EA	REF									3-38	A8A3E47C159
X1-D		CAPACITOR, FIXED, CERAMIC 6S8083, (56289)		EA	REF									3-38	A8A3E47C160
X1-D		CAPACITOR, FIXED, CERAMIC 6S8083, (56289)		EA	REF									3-38	A8A3E47C161
X1-D		CAPACITOR, FIXED, CERAMIC 6S8083, (56289)		EA	REF									3-38	A8A3Eh7C177
X1-D		CAPACITOR, FIXED, CERAMIC 6S8083, (56289)		EA	REF									3-38	A8A3E47C178
X1-D		CAPACITOR, FIXED, CERAMIC- 6S8083, (56289)		EA	REF									3-38	A8A3E47C183
X1-D		CAPACITOR, FIXED, MICA- CM05SD200JO3, (81349)		EA	1									3-38	A8A3Eh7C180
X1-D		CAPACITOR, FIXED, M CM05CDIOD0D3, (81349)		EA	1									3-38	A8A3E47C165
X1-D		CAPACITOR, FIXED, MICA CMD5FD391JO3, (81349)		EA	1									3-38	A8A3E47C148
X1-D		CAPACITOR, FIXED, MICA. DM15F511J30OOWVCR, (72136)		EA	8									3-38	A8A3E47C145
X1-D		CAPACITOR, FIXED, MICA DM15F511J300WV4hCR; (72136)		EA	REF									3-38	A8A3E47C147
X1-D		CAPACITOR, FIXED, MICA DM15F511J300Ov4CR; (72136)		EA	REF									3-38	A8A3E47C149
X1-D		CAPACITOR, FIXED, MICA- DM15F511J300WVhCR; (72136)		EA	REF									3-38	A8A3E47C152
X1-D		CAPACITOR, FIXED, MICA DM5F511J30WVh4CR, (72%36)		EA	REF									3-38	A8A3E47C155
XL-D		CAPACITOR, FIXED, MICA DM15F511J30OOWV4CR, (72136)		EA	REF									3-38	A8A3E47C157
X1-D		CAPACITOR, FIXED, MICA. DM15F511J300WV4CR, (72136)		EA	REF									3-38	A8A3E47C176
X1-D		CAPACITOR, FIXED, MICA: DM15F511J300WV4CR; (72136)		EA	REF									3-38	A8A3E47C181

****REPAIR PARTS FOR DIRECT SUPPORT, GENERAL SUPPORT, AND DEPOT MAINTENANCE (continued)****															
(1) SMR CODE	(2) FEDERAL STOCK NUMBER	(3) DESCRIPTION Reference Number & Mfr. Code Usable on Code		(4) UNIT OF MEAS	(5) QTY INC IN UNIT	(6) 30 DAY DS MAINTENANCE ALLOWANCE			(7) 30 DAY GS MAINTENANCE ALLOWANCE			(8) 1 YR ALW PER 100 EQUIP CNTGCTY	(9) DEPOT MAINT ALW PER 100 EQUIP	(10) ILLUSTRATION	
						(a) 1-20	(b) 21-50	(c) 51-100	(a) 1-20	(b) 21-50	(c) 51-100			(a) FIG NO.	(b) ITEM NO. OR REFERENCE DESIGNATION
XL-D		JACK, TIP 105-734-100; (74970)		EA	1									3-38	A8A3E47J5
X1-D		JACK, TIP: 105-740-100, (74970)		EA	1									3-38	A8A3E47J6
X1-D		RESISTOR, FIXED, COMPOSITION RCR07G270KS, (81349)		EA	2									3-38	ABA3E47R24
X1-D		RESISTOR, FIXED, COMPOSITION RCR07G270KS, (81349)		EA	REF									3-38	ABA3E47R30
X1-D		RESISTOR, FIXED, COMPOSITION RCR07C101KS, (81349)		EA	1									3-38	A8A3E47R41
X1-D		RESISTOR, FI-XED, COMPOSITION RCR07C121KS; (81349)		EA	3									3-38	A8A3E47R43
X1-D		RESISTOR, FIXED, COMPOSITION. RCR07G121KS; (81349)		EA	RE									3-38	ABA3E47R57
X1-D		RESISTOR, FIXED, COMPOSITION' RCR7OG121KS, (81349)		EA	REF									3-38	A8A3E47RI19
X1-D		RESISTOR, FIXED, COMPOSITION RCR07G331KS, (81349)		EA	1									3-38	A8A3E47R143
X1-D		RESISTOR, FIXED, COMPOSITION RCRO7G561KS, (81349)		EA	5									3-38	A8A3E47R28
X1-D		RESISTOR, FIXED, COMPOSITION: RCR07G561KS, (81349)		EA	REF									3-38	A8A3E47R37
X1-D		RESISTOR, FIXED, COMPOSITION RCR07G561KS, (81349)		EA	REF									3-38	A8A3E47Rs4
X1-D		RESISTOR, FIXED, COMPOSITION RCRO7G561KS, (81349)		EA	REF									3-38	ABA3E47R139
X1-D		RESISTOR, FIXED, COMPOSITION RCR07G561KS, (81349)		EA	REF									3-38	A8A3E47R144
X1-D		RESISTOR, FIXED, COMPOSITION RCR07G821KS, (81349)		EA	1									3-38	A8A3E47R42
X1-D		RESISTOR, FIXFD, COMPOSITION- RCRO7G1021S, (81349)		EA	7									3-38	A8A3E47R34
X1-D		RESISTOR, FIXED, COMPOSITION RCR07G102KS, (81349)		EA	REX									3-38	A8A3E47R46
X1-D		RESISTOR, FIXED, COMPOSITION RCR07GIO2KS, (81349)		EA	REF									3-38	A8A3E47R47
X1-D		RESISTOR, FIXED, COMPOSITION RCRO7G102KS, (81349)		EA	REF									3-38	A8A3E47R50
X1-D		RESISTOR, FIXED, COMPOSITION RCR07G102KS; (81349)		EA	RE									3-38	ABA3E47R51
X1-D		RESISTOR, FIXED, COMPOSITION RCRD7G102KS, (81349)		EA	REF									3-38	ABA3E47R55
X1-D		RESISTOR, FIXED, COMPOSITION RCR07G102KS, (81349)		EA	REF									3-38	A8A3E47R138
X1-D		RESISTOR, FIXED, COMPOSITION RCRO7G222KS, (81349)		EA	2									3-38	A8A3E47R29
X1-D		RESISTOR, FIXED, COMPOSITION RCR07G222KS, (81349)		EA	REF									3-38	A8A3E47R32
XL-D		RESISTOR, FIXED, COMPOSITION RCR07G332KS, (81349)		EA	1									3-38	A8A3E47R36

SECTION II

TM 11-5820-509-35

****REPAIR PARTS FOR DIRECT SUPPORT, GENERAL SUPPORT, AND DEPOT MAINTENANCE (continued)****															
(1) SMR CODE	(2) FEDERAL STOCK NUMBER	(3) DESCRIPTION Reference Number & Mfr. Code Usable on Code		(4) UNIT OF MEAS	(5) QTY INC IN UNIT	(6) 30 DAY DS MAINTENANCE ALLOWANCE			(7) 30 DAY GS MAINTENANCE ALLOWANCE			(8) 1 YR ALW PER 100 EQUIP CNTGCTY	(9) DEPOT MAINT ALW PER 100 EQUIP	(10) ILLUSTRATION	
						(a)	(b)	(c)	(a)	(b)	(c)			(a) FIG NO.	(b) ITEM NO. OR REFERENCE DESIGNATION
						1-20	21-50	51-100	1-20	21-50	51-100				
X1-D		RESISTOR, FIXED, COMPOSITION. RCR07G472S, (81349)		EA	1									3-38	A8A3E47R142
XI-D		RESISTOR, FIXED, COMPOSITION: RCR07G682KS, (e13h9)		EA	1									3-38	A8A3E47R39
X1-D		RESISTOR, FIXED, COMPOSITION. RCRo7C822KS; (813h9)		EA	3									3-38	A8A3Eh7Rh0
XI-D		RESISTOR, FIXED, COMPOSTION: RCRo7c822KS; (81349)		EA	REF									3-38	A8A3E47Rh5
X1-D		RESISTOR, FIXED, COMPOSITION: RCR07G822KS, (81349)		EA	REF									3-38	A8A3E47R4g
XI-D		RESISTOR, FIXED, CODPOSITION: RCR07GIO3KS; (813h9)		EA	4									3-38	A8A3Eh7R25
XI-D		RESISTOR, FIXED, COMPOSITION: RCR07G103KS; (81349)		EA	REF									3-38	A8A3E47Rh4
X1-D		RESISTOR, FIXED, COMPOSITION: RCR07CG03KS; (81349)		FA	RF									3-38	A8A3E47R48
X1-D		RESISTOR, FIXED, COMPOSITION: RCR07G103KS, (813h9)		EA	REF									3-38	A8A3E47R56
XI-D		RESISTOR, FIXED, COMPOSITION: RCR07G123KS; (8134 9)		EA	7									3-38	A8A3E47R31
X1-D		RESISTOR, FIXED, CODPOSITION: RCR07G123KS; (81349)		EA	REF									3-38	A8A3Eh7R35
X1-D		RESISTOR, FIXED, COMPOSITION. RCRD7G123KS, (81349)		EA	REF									3-38	A8A3Eh7R52
X1-D		RESISTOR, FIXED, COMPOSITION- RCR07G123KS, (81349)		EA	REF									3-38	A8A3Eh7R53
X1-D		RESISTOR, FIXED, COMPOSITION: RCR07G123KS; (813h9)		EA	REF									3-38	A8A3E47R136
XI-D		RESISTOR, FIXED, COMPOSITION- RCR07G123KS; (81349)		EA	REF									3-38	A8A3Eb7R137
X1-D		RESISTOR, FIXED, COMPOSITION: RCR07G1?3KS; (813h9)		EA	REF									3-38	A8A3E47R1
X1-D		RESISTOR, FIXED, COMPOSITIOB- RCR07G?21KS; (81349)		EA	2									3-38	A8A3E47R26
X1-D		RESJSTOR, FIXED, COMPOSITION RCR07G?23XS; (81349)		EA	REF									3-38	A8A3E47R27
X1-D		RESISTOR, FIXED, COMPOSITION: RCR07C333KS, (/813b9)		EA	2									3-38	A8A3E47RI40
X1-D		RESISTOR, FIXED, COMPOSITION RCR07G333KS; (813h9)		EA	REF									3-38	AA3E47RI45
X1-D		RESISTOR, FIXED, FILM Rn60D1960F; (81349)		EA	2									3-38	A8A3E47R33
X1-D		RESISTOR, FIXED, FILM. RN6,DJ960F, (81349)		EA	REF									3-38	A8A3E47R38
X1-D		SEMICONDUCTOR DEVICE, DIODE- 16645; (07688)		EA	2									3-38	A8A3E47CR5
XI-D		SEMICONDUCTOR DEVICE, DIODE 1N6h5, (o7688)		EA	REF									3-38	A8A3E47CR6
XJ-D		TRANSISTOR. 2N703, (07688)		EA	7									3-38	A8A3E47Q2

SECTION II

TM 11-5820-509-35

****REPAIR PARTS FOR DIRECT SUPPORT, GENERAL SUPPORT, AND DEPOT MAINTENANCE (continued)****															
(1) SMR CODE	(2) FEDERAL STOCK NUMBER	(3) DESCRIPTION Reference Number & Mfr. Code Usable on Code		(4) UNIT OF MEAS	(5) QTY INC IN UNIT	(6) 30 DAY DS MAINTENANCE ALLOWANCE			(7) 30 DAY GS MAINTENANCE ALLOWANCE			(8) 1 YR ALW PER 100 EQUIP CNTGCTY	(9) DEPOT MAINT ALW PER 100 EQUIP	(10) ILLUSTRATION	
						(a)	(b)	(c)	(a)	(b)	(c)			(a)	(b)
						1-20	21-50	51-100	1-20	21-50	51-100			FIG NO.	ITEM NO. OR REFERENCE DESIGNATION
X1-D		TRANSISTOR: 2N703, (07688)		EA	REF									3-38	ABA3E47QS
X1-D		TRANSISTOR: 2N703, (07688)		EA	REF									3-38	A8A3E47Q6
X1-D		TRANSISTOR 2N703, (07688)		EA	REF									3-38	A8A3E47Q7
X1-D		TRANSISTOR. 2N703; (07688)		EA	REF									3-38	A8A3E47Q8
X1-D		TRANSISTOR: 2N703; (07688)		EA	REF									3-38	ABA3E47Q12
X3-D		TRANSISTOR: 2N703, (07688)		EA	REF									3-38	A8A3E47Q13
X1-D		TRANSISTOR: MM2181, (04713)		EA	2									3-38	A8A3E47Q3
X1-D		TRANSISTOR: M1181, (04713)		EA	REF									3-38	A8A3E477Q
P-H-T	5820-981-5877	AMPLIFIER,RADIO FREQUENCY, FIRST: 549-6522-003, (13499)		EA	1				*	*	*	*	*	3-10	ABA3TBi
P-D	5305-938-4044,	SCREW, MACHINE: P342-0152-00, (T7250)		EA	2							*	*		ABA3TBLR2
P-D	5305-576-6002	SCREW, MACHINE P343-o298-ooo; (77250)		EA	1							REF	REF		ABA3TBH1
P-D	5310-680-5557	WASHER, SPRING TENSION 31n n075-000, (79807)		EA	1							REF	REF		A8A3TBIH
X1-D		BO ., TERMINAL 549-65.7-000, (13499)		EA	1									3-22	ABA3TBIEI
X1-D		CAPACITOR, FIXED, CERAMIC CK1 4BX223N, (81349)		EA	2									3-22	AdA31Cb3
X1-D		CAPACITOR, FTXED, CERAXIC CK14HX22T13, (81349)		EA	REF									3-22	A8A3TB1C66
X1-D		CAPACITOR, FIXED, MICA: D15F511J3Orv4hCR; (72136)		EA	2									3-22	A8A3rBC61
X1-D		CAPACITOR, FIXED, MICA: DM15F511J300Wv4CR, (72136)		EA	REF									3-22	BA3BIC65
X1-D		RESISTOR, FIXED, COMPOSTION. RCR07C680KS, (81 3)9)		EA	1									3-22	A8A3TB1R3
X1-D		RESISTOR, FIXED, COMPOSITIOR RCR07GCIOIKS; (81349)		EA	1									3-22	A8A3TBiR6
X1-D		RESISTOR, FIXED, COWMOSITIORN RCR07G102KS; (81349)		EA	1									3-22	*8A3TBiIR
X1-D		RESISTOR, FI-.XED, COMPOSITION RCR07C103KS, (81349)		EA	1									3-22	ABA3TBRI
XI-D		RESISTOR, FIXED, COMPOSITTOR RCR07G104KS; (81349)		EA	1									3-22	A8A3TB1R2
X1-D		SHIELD, ELECTRON TUBE T3A361R, (98978)		EA	1									3-22	A8A3TBE2
X1-D		SUPPRESSOR, PARASITIC F193-1-01, (72656)		EA	1									3-22	A8A3TRIE3
X1-D		TERMIAl., LUG 4007-4HT, (77147)		EA	3										ABA3TB1E4

****REPAIR PARTS FOR DIRECT SUPPORT, GENERAL SUPPORT, AND DEPOT MAINTENANCE (continued)****															
(1) SMR CODE	(2) FEDERAL STOCK NUMBER	(3) DESCRIPTION Reference Number & Mfr. Code Usable on Code		(4) UNIT OF MEAS	(5) QTY INC IN UNIT	(6) 30 DAY DS MAINTENANCE ALLOWANCE			(7) 30 DAY GS MAINTENANCE ALLOWANCE			(8) 1 YR ALW PER 100 EQUIP CNTGCV	(9) DEPOT MAINT ALW PER 100 EQUIP	(10) ILLUSTRATION	
						(a) 1-20	(b) 21-50	(c) 51-100	(a) 1-20	(b) 21-50	(c) 51-100			(a) FIG NO.	(b) ITEM NO. OR REFERENCE DESIGNATION
X1-D		NUT, PLAIN, HEXAGON' P313-0156-000, (77250)		EA	1										ABA3TB1E4H1
X1-D		SCREW, MACHINE P343-0285-000, (77250)		EA	1										AA3TB1ELH2
X1-D		WASHER, SPRING TENSION 310-0396-00, (79807)		EA	1										ABA3TB1EhH3
X1-D		TEMWINAL, LUG 4007-4HT, (77147)		EA	REF										A8A3TBIE5
X1-D		NUT, PLAIN, HEXAGON- P313-O156-000, (T7250)		EA	1										A8A3TB1ES5H
X1-D		SCREW, MACHINE P343-0285-00, (77250)		EA	1										A8A3TB1E5H2
X1-D		WASHER, SPRING TENSION' 310-0396-00, (79807)		EA	1										A8A3TBIE5H3
X1-D		TERMINAL, LUG 4007-4HT, (77147)		EA	REF										A8A3TB1E6
X1-D		NUT, PLAIN, HEXAGON: P313-O156-000, (77250)		EA	1										A8A3TBLE6H1
X1-D		SCREW, MACHINE P343-0285-000, (77250)		EA	1										A8A3TB1E6H2
X1-D		WASHER, SPRING TENSION. 310-0396-00, (79807)		EA	1										A8A3TB1E6H3
X1-D		TUBE, ELECTRON. JAN 5907, (81349)		EA	1								3-22		A8A3TBVIV
P-H-T	5820-995-6535	AMPLIFIER, RADIO REQUENCY, SECOND- 549-6521-003, (13499)		EA					*	*	*	*	*		A8A3TB2
P-D	5305-576-6002	SCREW, MACHINE- P343-O298-000, (77250)		EA	1								REF	REF	A8A3TB2H1
P-D	5305-938-40bl	SCREW, MACHINE: P342-0152-000, (77250)		EA	2								REF	REF	A8A3TB2H2
P-D	5310-680-5557	WASHER, SPRING TENSION: 310-0075-000; (79807)		EA	1								REF	REF	A8A3TB2H1
X1-D		BOARD, TERMINAL, SECOND 549-6529-0000, (13499)		EA	1									3-23	A8A3TB2E1
X1-D		CAPACITOR, FIXED, CERAMIC. DA146; (71590)		EA	2									3-23	A8A3TB2C89
X1-D		CAPACITOR, FIXED, CERAMIC DA146, (71590)		EA	REF									3-23	A8A3TB2C90
X1-D		CAPACITOR, FIXED, MICA CMD5ED270003, (813h9)		EA	1									3-23	A8A3TB2C187
X1-D		CAPACITOR, FIXED, MICA- Ds5F5IJ300WVVCr; (72136)		EA	1									3-23	A8A3TB2C92
X1-D		RELAY, ARMATURE: 310-Lols-100l, (80294)		EA	1									3-23	A8A3TB2K1
X1-D		SCREW, MACHINE P343-0298-000, (77250)		EA	2									3-23	A8A3TB2K1H1
X1-D		SCREW, MACHINE P343-0298-000, (77250)		EA	REF									3-23	A8A3TB2K.H2
X1-D		WASHER, LOCK. 310-0075-000, (79807)		EA	2										A8A3TB2K1H3

****REPAIR PARTS FOR DIRECT SUPPORT, GENERAL SUPPORT, AND DEPOT MAINTENANCE (continued)****															
(1) SMR CODE	(2) FEDERAL STOCK NUMBER	(3) DESCRIPTION Reference Number & Mfr. Code Usable on Code		(4) UNIT OF MEAS	(5) QTY INC IN UNIT	(6) 30 DAY DS MAINTENANCE ALLOWANCE			(7) 30 DAY GS MAINTENANCE ALLOWANCE			(8) 1 YR ALW PER 100 EQUIP CNTGCT	(9) DEPOT MAINT ALW PER 100 EQUIP	(10) ILLUSTRATION	
						(a)	(b)	(c)	(a)	(b)	(c)			(a) FIG NO.	(b) ITEM NO. OR REFERENCE DESIGNATION
						1-20	21-50	51-100	1-20	21-50	51-100				
X1-D		WASHER, LOCK 310-0075-000		EA	REF										A8A3TB2K1H4
X1-D		RESISTOR, FIXED, COMPOSITION RCR07G101KS, (81349)		EA	2								3-23		8A3TB2R1I
X1-D		RESISTOR, FIXED, COMPOSITION- RCR07G101KS; (81349)		EA	REF								3-23		A8A3TB2R14
X1-D		RESISTOR, FIXED, COMPOSITION RCR07G103KS, (81349)		EA	1								3-23		A8A3TB2R9
X1-D		RESISTOR, FIXED, COPOSITION: RCR07G123KS; (81349)		EA	1								3-23		ABA3TB2R13
X1-D		RESISTOR, FIXED, CONPOSITION- RCR07G10L(S), (81349)		EA	1								3-23		A8A3TB2R10
X1-D		SHIELD, ELECTODN TUBE: T3A361R; (98978)		EA	1								3-23		A8A3TB2E2
X1-D		SUPPRISSOR, PARASITIC F1913-1-01, (72656)		EA	1								3-23		A8A3TB2E3
X1-D		TERIINAL, LUG. 4040-2HT, (77147)		EA	4										A8A3TB2E4
X1-D		NUT, PLAIN, HEXAGCN: MS35649-225, (96906)		EA	1										A8A3TB2E4H1
X1-D		SCREW, MACHINE:: P343-0299-000, (77 250)		EA	1										A8A3TB2E4H2
X1-D		WASHER, SPRINGIC TENSION: 310-0075-000, (79807)		EA	1										AA3TB2E4H3
X1-D		TERMINAL, LUG- 4040-2HT, (77147)		EA	REF										A8A3TB2E5
X1-D		NUT, PLAIN, HEXAOII MS35649-225, (96906)		EA	1										A8A3TB2E5H1
X1-D		SCREW, MACHINE P343-0299-000, (77250)		EA	1										A8A3TB2E5H2
X1-D		WASHER, SPRING TNSIOI 310-0075-000, (79807)		EA	1										A8A3TB2E5H3
X1-D		TERMINAL, LUG 40400-2HT; (77147)		EA	REF										A8A3TB2E6
X1-D		NUT, PLAIN, HEXAGON MS35649-225, (96906)		EA	1										A8A3TB2E6H1
X1-D		SCREW, MACHINE' P343-0299-ooo, (77250)		EA	1										A8A3TB2E6H2
X1-D		WASHER, SPRING TESION'- 310-0075-000, (79807)		EA	1										A8A3TB2E6H3
X1-D		TERMINAL, LUG 4040-2HT, (77147)		EA	REF										A8A3TB2E7
X1-D		TERMINAL, LUG 4007-4HT, (77147)		EA	1										AATTB2E8
X1-D		NUT, PLAIN, HEXAGON P313-0156-ooo, (77250)		EA	1										A8A3TB2E8H1
X1-D		SCREW, MACHINE P343-0285-000, (77250)		EA	1										A8A3TB2E8H2
X1-D		WASHER, SPRING TENSION 310-0396-00, (79807)		EA	1										A8A3TB2E8H3

****REPAIR PARTS FOR DIRECT SUPPORT, GENERAL SUPPORT, AND DEPOT MAINTENANCE (continued)****															
(1) SMR CODE	(2) FEDERAL STOCK NUMBER	(3) DESCRIPTION Reference Number & Mfr. Code Usable on Code		(4) UNIT OF MEAS	(5) QTY INC IN UNIT	(6) 30 DAY DS MAINTENANCE ALLOWANCE			(7) 30 DAY GS MAINTENANCE ALLOWANCE			(8) 1 YR ALW PER 100 EQUIP CNTGCTY	(9) DEPOT MAINT ALW PER 100 EQUIP	(10) ILLUSTRATION	
						(a) 1-20	(b) 21-50	(c) 51-100	(a) 1-20	(b) 21-50	(c) 51-100			(a) FIG NO.	(b) ITEM NO. OR REFERENCE DESIGNATION
X1-D		TUBE, ELECTRON: 7761, (82219)		EA	1									3-23	A8A3TB2V2
M-D		ARM, SPRING 549-5869-002, (13499)		EA	2										A8A3MP1
M-D		ARM, SPRING. 549-5869-oo2; (13499)		EA	REF										ASA3MP2
P-D	3110-851-7674	BEARING, BALL, ANNULAR S6316FRHH3P15L02, (40920)		EA	2						*	*			A8A3MP3
P-D	3110-851-7674	BEARING, BALL, ANULAR. S6316FRHH3P15L02, (40920)		EA	REF						REF	REF			A8A3MP4
P-D	5820-977-7651	BELT, SLUG RACK 549-5860-002; (13499)		EA	2						*	*			A8A3MP5
P-D	5820-977-7651	BELT, SLUG RACK. 549-5860-002, (13499)		EA	REF						REF	REF			A8A3MP6
M-D		BUSHING, MACHINE THREAD: 548-7777-oo3, (13499)		EA	2										A8A3MP7
P-D	5310-275-5147	NUT, PLAIN, HEXAGON: P334-4120-000; (77250)		EA	1						*	*			ASA3MP7H1
M-D		BUSHING, MACHINE THRAD 548-7777-003; (13499)		EA	REF										AA3MP8
P-D	5310-275-5147	NUT, PLAIN, HEXACON. P334-4120-000, (77250)		EA	1						REF	REF			A8A3MP8H1
M-D		BUSHING, SCREW' 548-7783-002; (13499)		EA	1										A8A3MP9
P-D		CAPACITOR, FIXED, CERAMIC CK15BX104M; (81349)		EA	1						*	*	13-41		A8A3C189
P-D	5910-080-4020	CAPACITOR, FIXED, CERAMIC. 6s8083; (56289)		EA	3						*	*	3-40		A8A3C115
P-D	5910-080-4020	CAPACITOR, FIXED, CERAMIC 6S8083, (56289)		EA	REF						REF	REF	3-40		A8A3C116
P-D	5910-080-Oo20	CAPACITOR, FIXED, CERAMIC: 6S8083, (56289)		EA	REF						REF	REF	3-40		A8A3C293
P-D	5910-080-1713	CAPACITOR, FIXED, CERAMIC' DA146, (71590)		EA	4						*	*	3-41		AA3C188
P-D	5910-080-1713	CAPACITOR, FIXED, CERAMIC DA146, (71590)		EA	REF						REF	REF	3-41		A8A3C289
P-D	5910-080-1713	CAPACITOR, FIXED, CERAMIC- DA146, (71590)		EA	REF						REF	REF	3-41		A8A3C290
P-D	5910-080-1713	CAPACITOR, FIXED, CERAMIC DA146, (71590)		EA	REF						REF	REF	3-41		AA3C291
P-D	5910-762-2828	CAPACITOR, FIXED, CERAMIC: C023B102P223Z; (56289)		EA	2						*	*	3-40		A8A3C17
P-D	5910-762-2828	CAPACITOR, FIXED, CERAIC. C023B102P223Z, (56289)		EA	REF						REF	REF	3-40		A8A3C292
P-D	5910-649-7756	CAPACITOR, FIXED, GLASS VC22GY, (73899)		EA	1						*	*	3-40		AA3C344
P-D	5910-765-4415	CAPACITOR, FIXED, MICA D1910F511JO; (53021)		EA	1						*	*	3-40		ASA3C118
M-D	5325-960-2410	CHANNEL, PLASTIC MS21266-1N, (96906)		EA	4										A8A3MP10

****REPAIR PARTS FOR DIRECT SUPPORT, GENERAL SUPPORT, AND DEPOT MAINTENANCE (continued)****																
(1) SMR CODE	(2) FEDERAL STOCK NUMBER	(3) DESCRIPTION Reference Number & Mfr. Code Usable on Code		(4) UNIT OF MEAS	(5) QTY INC IN UNIT	(6) 30 DAY DS MAINTENANCE ALLOWANCE			(7) 30 DAY GS MAINTENANCE ALLOWANCE			(8) 1 YR ALW PER 100 EQUIP CNTGCTY	(9) DEPOT MAINT ALW PER 100 EQUIP	(10) ILLUSTRATION		
						(a) 1-20	(b) 21-50	(c) 51-100	(a) 1-20	(b) 21-50	(c) 51-100			(a) FIG NO.	(b) ITEM NO. OR REFERENCE DESIGNATION	
M-D	5325-960-2410	CHANNEL, PLASTIC M 21266-1I, (96906)		EA	REF											A8A3MP11
M-D	5325-960-2410	CHANNEL, PLASTIC- MS21266-1N, (96906)		EA	REF											A8A3MP12
M-D	5325-960-2410	CHANNEL, PLASTIC MS21266-1N, (96906)		EA	REF											A8A3MP13
M-D		CHASSIS, ELECTRICAL EQUIPM'- 548-7886-000, (13199)		EA	1											A8A3AI
P-D	5935-027-2636	JAC, TIP 69003-1183 BROWN (73680)		EA	1							*	*	3-9		A8A3AIJ1
P-D	5934-432-6501	JAC, TIP 69003-1183 RED (73680)		EA	1							*	*	3-9		ABA3A1J2
P-D	5935-683-7648	JACK, TIP 69003-1183 ORANGE (73680)		EA	1							*	*	3-9		A8A3AIJ3
P-D	5935-683-7649	JACK, TP 69003-1183YELLOW (73680)		EA	1							*	*	3-9		ABA3A1Jh
P-D		CLAMP, LOOP-TUIER- 504-7577-002, (13499)		EA	1							*	*			ASA3PI12
P-D	5310-276-1104	NUT, PLAIN, SQUARE. P334-0085-000, (77250)		1	*							*	*			A8A3MP12H
P-D	5305-952-1410	SCREW, CAP- 324-1682-100, (08664)		EA	1							*	*			ABA3MP12H2
MD	5820-977-7650	CLIP-TAPE 549-5862-002, (13499)		EA	2											AA3MP13
P-D	5305-141-4310	SCREW, MACHINE P347-0021-000, (77250)		EA	1							*	*			A8A3M13H1
M-D	5820-977-7650	CLIP-TAPE 549-5862-002, (13499)		EA	REF											A8A3MP14
P-D	5305-141-4310	SCREW, MACHINE P347-0021-000, (77250)		EA	1							REF	REF			A8A3MPi1H1
P-D	5950-766-7833	COIL, RADIO FREQUENCY. 240-1994-000, (13499)		EA	1							*	*	3-40		ABA3L98
P-D	5305-770-2533	SCREW, MACHINE MS51959-13, (96906)		EA	1							REF	REF			A8A3L98H1
P-D	5310-782-1349	WASHER, LAT 310-0045-000, (79807)		EA	1							REF	REF			A8A3L98H2
P-D	5950-932-2727	COIL, RADIO FREQUENCY LT10K029, (81349)		EA	2							*	*	3-40		A8A3L120
P-D	5950-932-2727	COIL, RADIO FREQUENCY- LT1CK029, (81349)		EA	REF							REF	REF	3-40		ABA3L121
P-D	5950-960-7850	COIL, RADIO FREQUENCY. 548-7797-004, (13499)		EA	1							*	*	3-41		A8A3L145
P-D		SCREW, MACHINE P347-0024-000, (77250)		EA	3							*	*			A8A3L145H
P-D		SCREW, MACHINE P347-0024-000, (77250)		EA	REF							REF	REF			A8A3L145H2
P-D		SCREW, MACHINE P347-0024-000, (77250)		EA	REF							REF	REF			A8A3L145H3
P-D	5950-950-4176	COIL, RADIO FREQUENCY. 5L9-5972-002, (13499)		EA	3							*	*	3-41		AA3L1

****REPAIR PARTS FOR DIRECT SUPPORT, GENERAL SUPPORT, AND DEPOT MAINTENANCE (continued)****															
(1) SMR CODE	(2) FEDERAL STOCK NUMBER	(3) DESCRIPTION Reference Number & Mfr. Code Usable on Code		(4) UNIT OF MEAS	(5) QTY INC IN UNIT	(6) 30 DAY DS MAINTENANCE ALLOWANCE			(7) 30 DAY GS MAINTENANCE ALLOWANCE			(8) 1 YR ALW PER 100 EQUIP CNTGCTY	(9) DEPOT MAINT ALW PER 100 EQUIP	(10) ILLUSTRATION	
						(a) 1-20	(b) 21-50	(c) 51-100	(a) 1-20	(b) 21-50	(c) 51-100			(a) FIG NO.	(b) ITEM NO. OR REFERENCE DESIGNATION
P-D	5950-950-4176	COIL, RADIO FREQUENCY- 549-5972-002, (13499)		EA	REF							REF	REF	3-41	A8A3L2
P-D	5950-950-4176	COIL, RADIO FREQUENCY: 519-5972-002; (13499)		EA	REF							REF	REF	3-41	A8A3L3
P-D	5950-044-2428	COIL, RADIO FREQUENCY: 756-3160-003, (13499)		EA	1							*	*	3-1	A8A3L5
P-D	5950-044-2429	COIL, RADIO FREQUENCY: 756-4179-003, (13499)		EA	1							*	*	3-41	A8A3L4
P-D		CONNECTOR, RECEPTACLE, ELECTRICAL DAMW2P; (71468)		EA	4							REF	REF	3-41	AA3P1
P-D	5310-685-7739	NUT, PLAIN, CAP 334-0043-000; (21537)		EA	1							*	*		A8A3PH1
P-D	5310-275-0889	NUT, PLAIN, HEXAON P313-0132-000, (77250)		EA	1							*	*		A8A3P1H2
P-D	5305-770-2533	SCREW, MACHINE. MS51959-13, (96906)		EA	1							REF	REF		A8A3P1H3
P-D	5305-763-7822	SCREW, MACHINE: Ms51959-14; (96906)		EA	1							REF	REF		A8A3P1H4
P-D		WASHER, FLAT 310-6325-000, (79807)		EA	1							REF	REF		ABA3P1H5
P-D	5310-058-2949	WASHER, LOCK 310-0278-000, (70318)		EA	2							*	*		ARA3P1H6
P-D	5310-058-2949	WASHER, LOCK 310-0278-000, (70318)		EA	REF							REF	REF		48A3P1H7
P-D		CONNECTOR, RECEPTACLE, ELECTRICAL DAMTW2P, (71468)		EA	REF							REF	REF	3-41	A8A3P2
P-D	5310-685-7 739	NUT, PLAIN, CAP 334-0043-000, (21537)		EA	1							REF	REF		A8A3P2H1
P-D	5310-275-0889	NUT, PLAIN, HEXAGON- P313-0132-000; (77250)		EA	1							REF	REF		A8A3P2H2
P-D	5305-770-2533	SCREW, MACHINE MS51959-13, (96906)		EA	2							REF	REF		A8A3P2H3
P-D	5305-770-2533	SCREW, MACHINE MS51959-13, (96906)		EA	REF							REF	REF		A8A3P2H4
P-D	5310-058-2949	WASHER, LOCK 310-0278-000, (70318)		EA	1							REF	REF		A8A3P2H5
P-D		CONNECTOR, RECEPTACLE, ELECTRICAL DAMTW2P, (71468)		EA	REF							REF	REF	3-41	A8A3P3
P-D	5310-685-7739	NUT, PLAIN, CAP 33-00003-000, (21537)		EA	1							REF	REF		A8A3P3H1
P-D	5310-275-0889	NUT, PLAIN, HEXAGON P313-0132-000, (77250)		EA	1							REF	REF		A8A3P3H2
P-D	5305-770-2533	SCREW, MACHINE: MS51959-13, (96906)		EA	2							REF	REF		A8A3P3H 3
P-D	5305-770-2533	SCREW, MACHINE MS51959-13, (96906)		EA	REF							REF	REF		A8A3P3H 4
P-D	5310-058-2949	WASHER, LOCK 310-0278-000; (70318)		EA	1							REF	REF		A8A3P3H 5
P-D		CONNECTOR, RECEPTACLE, ELECTRICAL DAM7W2P, (71468)		EA	REF							REF	REF	3-41	A8A3P4

SECTION II

TM 11-5820-509-35

****REPAIR PARTS FOR DIRECT SUPPORT, GENERAL SUPPORT, AND DEPOT MAINTENANCE (continued)****															
(1) SMR CODE	(2) FEDERAL STOCK NUMBER	(3) DESCRIPTION Reference Number & Mfr. Code Usable on Code		(4) UNIT OF MEAS	(5) QTY INC IN UNIT	(6) 30 DAY DS MAINTENANCE ALLOWANCE			(7) 30 DAY GS MAINTENANCE ALLOWANCE			(8) 1 YR ALW PER 100 EQUIP CNTGCTY	(9) DEPOT MAINT ALW PER 100 EQUIP	(10) ILLUSTRATION	
						(a)	(b)	(c)	(a)	(b)	(c)			(a) FIG NO.	(b) ITEM NO. OR REFERENCE DESIGNATION
						1-20	21-50	51-100	1-20	21-50	51-100				
P-D	5310-685-7739	NUT, PLAIN, CAP 334-0043-000, (21537)		EA	1							REF	REF		A8A3P4H1
P-D	5310-275-0889	NUT, PLAIN, HEXAGON P313-0132-000, (77250)		EA	1							REF	REF		A8A3P4H2
P-D	5305-770-2533	SCREW, MACHINE MS519-13, (96906)		EA	2							REF	REF		A8A3P4H3
P-D	5305-770-2533	SCREW, MACHINE MS51959-13, (96906)		EA	REF							REF	REF		A8A3P4H4
P-D	5310-058-2949	WASHER LOCK 310-0278-000; (70318)		EA	1							REF	REF		A8A3P4HS
P-D	5935-885-6505	CONTACT, ELECTRICAL DM53740-5000, (71468)		EA	8							REF	REF		A8A3PIA1
P-D	5935-885-6505	CONTACT, ELECTRICAL DM53740-500, (71468)		EA	REF							REF	REF		AsA3PIA2
P-D	5935-885-6505	CONTACT, ELECTRICAL DM53740-5000, (71468)		EA	REF							REF	REF		ASA3P2A1
P-D	5935-885-6505	CONTACT, ELECTRICAL. DM53740-5000, (71468)		EA	REF							REF	REF		A8A3P2A2
P-D	5935-885-6505	CONTACT, ELECTRICAL DM53740-5000; (71468)		EA	REF							REF	REF		A8A3P3A1
P-D	5935-885-6505	CONTACT, ELECTRICAL DM53740-500000, (71468)		EA	REF							REF	REF		A8A3P3A2
P-D	5935-885-6505	CONTACT, ELECTRICAL. DM53740-5000; (71468)		EA	REF							REF	REF		A8A3P4A1
P-D	5935-885-65b5	CONTACT, ELECTRICAL DM53740-5000; (71468)		EA	REF							REF	REF		A8A3PIA2
P-D	5950-4501161	CORE, ADJUSTABLE TUNING 57-3540, (78488)		EA	6							*	*	3-9	AsA3E1
P-D		CORE, ADJUSTABLE TUNING 57-3540, (78488)		EA	REF							REF	REF	3-9	AsA3E2
P-D		CORE, ADJUSTABLE TUNING EA 57-3540; (78L88)		REF	REF							REF	REF	3-9	A8A3E3
P-D		CORE, ADJUSTABLE TUNING 57-3540, (78L88)		EA	REF							REF	REF	3-9	AsA3E4
P-D		CORE, ADJUSTABLE TUNING 57-3540, (78488)		EA	REF							REF	REF	3-9	ASA3E5
P-D		CORE, ADJUSTABLE TUNING 57-3540, (78488)		EA	REF							REF	REF	3-9	A8A3E6
M-D		COUPLING HALF ASSERBLY. 549-5881-002; (13499)		EA	1										AsA3A2
M-D		COUPLING HALF, SHAFT 549-5853-002, (13499)		EA	1										AA3A2MP1
M-D		INSERT, FLEXIBLE COUPLING 553-9786-003, (13499)		EA	1										AsA3A2MP2
M-D		PIN, LOCATING 549-5721-002, (13499)		EA	1										A8A3A2MP3
M-D		COVER, CIRCUIT BOARD 549-6525-003, (13499)		EA	1										A8A3MP15
P-D	5305-805-9801	SCREW, MACHINE P347-0090-00,0, (77250)		EA	4							33	20		ASA3P15H1

****REPAIR PARTS FOR DIRECT SUPPORT, GENERAL SUPPORT, AND DEPOT MAINTENANCE (continued)****															
(1) SMR CODE	(2) FEDERAL STOCK NUMBER	(3) DESCRIPTION Reference Number & Mfr. Code Usable on Code		(4) UNIT OF MEAS	(5) QTY INC IN UNIT	(6) 30 DAY DS MAINTENANCE ALLOWANCE			(7) 30 DAY GS MAINTENANCE ALLOWANCE			(8) 1 YR ALW PER 100 EQUIP CNTGCTY	(9) DEPOT MAINT ALW PER 100 EQUIP	(10) ILLUSTRATION	
						(a) 1-20	(b) 21-50	(c) 51-100	(a) 1-20	(b) 21-50	(c) 51-100			(a) FIG NO.	(b) ITEM NO. OR REFERENCE DESIGNATION
P-D	5305-805-9801	SCREW, MACHINE- P347-0090-000, (77250)		EA	REF							REF	REF		A8A3MP15H2
P-D	5305-805-9801	SCREW, MACHINE: P347-0090-000, (77250)		EA	REF							REF	REF		A8A3MP15H3
P-D	5305-805-9801	SCREW, MACHINE: P347-0090-DOD; (77250)		EA	REF							REF	REF		A8A3MP15H4
P-D	5310-685-1971	WASHER, SPRING TENSION 310-0396-00; (79807)		EA	4							REF	REF		A8A3MP15H5
P-D	5310-685-1971	WASHER, SPRING TENSION 310-0396-OC, (79807)		EA	REF							REF	REF		A8A3MP15H6
P-D	5310-685-1971	WASHER, SPRING TENSION- 310-0396-0000, (79807)		EA	REF							REF	REF		A8A3P15H7
P-D	5310-685-1971	WASHER, SPRING TENSION: 310-0396-00; (79807)		EA	REP							REF	REF		A8A3MP15H8
P-D	5820-015-1607	FILTER ASSEMBLY, RADIO FREQUENCY 756-3172-002; (13499)		EA	1							*	*	3-41	A8A3A2
P-D	5310-614-3500	NUT, SELF-LOCKING, OIKXAGON: 68-1660-40, (72962)		EA	2							REF	REF		A8A3A2H2
P-D	5305-054-5647	SCREW, MACHINE: MS51957-13; (96906)		EA	2							REF	REF		A8A3A2H2
X1-D		CABLE, RADIO FREQUENCY: RG178TBU; (80058)		EA	1										A8A3A2W1
X1-D		CAPACITOR, FIXED, CERAMIC: 2465-008WST0102P; (72982)		EA	3									3-41	A8A3A2C350
X1-D		CAPACITOR, FIXED, CERAMIC- 2465-00WS5TO102P; (72982)		EA	REF									3-41	A8A3A2C351
X1-D		CAPACITOR, FIXED, CERAMIC: 2465-008WST0102P, (72982)		EA	REF									3-41	A8A3A2C352
X1-D		PLATE, MOUNTING, CAPACITOR. 756-3174-002, (13499)		EA	1										A8A3A2MPI
P-D	5325-174-5317	GROMMET, RUBBER. YS35489-4, (96906)		EA	1							REF	REF		A8A3H1
P-D	5325-276-4993	DORET, RUBBER. 905, (75543)		EA	1							*	*		A8A3H2
M-D		HARNES, WIRING, BRANCHED: 549-583-0000; (13499)		EA	1										A8A3W1
N-D		HARNES, WIRING, BRANCHED: 756-3168-005; (13499)		EA	1										A8A3W2
P-D	5820-960-7844	HEATSINK, ELECTRON TUBE 549-6523-003; (13499)		EA	1										A8A3E7
P-D		SCREW, SELF-LOCKING: LP51959-13M, (03038)		EA	4							REF	REF		A8A3E7H1
P-D		SCREW, SELF-LOCKING. LP51959-134; (03038)		EA	REF							REF	REF		A8A3E7H2
P-D		SCREW, SELF-LOCKING: LP51959-13M, (03038)		EA	REF							REF	REF		A8A3E7H3
P-D		SCREW, SELF-LOCKING' LP51959-13M; (03038)		EA	REF							REF	REF		A8A3E7H4
P-D	5995-426-1599	LEAD, ELECTRICAL. 549-6598-002, (13499)		EA	1							*	*		A8A3A3

****REPAIR PARTS FOR DIRECT SUPPORT, GENERAL SUPPORT, AND DEPOT MAINTENANCE (continued)****															
(1) SMR CODE	(2) FEDERAL STOCK NUMBER	(3) DESCRIPTION Reference Number & Mfr. Code Usable on Code		(4) UNIT OF MEAS	(5) QTY INC IN UNIT	(6) 30 DAY DS MAINTENANCE ALLOWANCE			(7) 30 DAY GS MAINTENANCE ALLOWANCE			(8) 1 YR ALW PER 100 EQUIP CNTGCTY	(9) DEPOT MAINT ALW PER 100 EQUIP	(10) ILLUSTRATION	
						(a)	(b)	(c)	(a)	(b)	(c)			(a) FIG NO.	(b) ITEM NO. OR REFERENCE DESIGNATION
						1-20	21-50	51-100	1-20	21-50	51-100				
P-D	531-275-0889	NUT, PLAIN, HEXAGON: P313-0132-000, (77250)		EA	2							REF	REF	A8A3A3H2	
P-D	5305-051-567	SCREW, MACHINE: MS51957-13, (96906)		EA	2							REF	REF	A8A3A3H2	
P-D	5310-29-0960	WASHER, LOCK: 1704-03; (78189)		EA	2							*	*	A3A3H2	
X1-D		BRAID, WIRE: 36109; (75818)		EA	1									A8A3A3W1	
X1-D		TERMINAL, LUG: 321k2; (0sTT9)		EA	2									A8A3A3E1	
X1-D		TERMINAL, LUG: 32442; (00779)		EA	REF									A8A3A3E2	
P-D	6150-182-1993	LEAD, ELECTRICAL-GROUND STRIP: 553-9321-002; (13499)		EA	2							*	*	AA3E8	
P-D		LEAD, ELECTRICAL-GROUND STRIP: 553-9321-002; (13499)		EA	REF							REF	REF	A8A3E9	
P-4-T	5820-042-5719	MIXER STAGE, FREQUENCY: 549-6000-004; (13199)		EA	1				*	*	*	*	*	3-9 A8A3E48	
P-D		SCREW, SELF-LOCKING: LP51959-13M; (03038)		EA	4							REF	REF	A8A3E48H4	
X1-D		BOARD, PRINTED CIRCUIT: 549-5999-004; (13499)		EA	1									3-39 A8A3E48E1	
X1-D		CAPACITOR, FIXED, CIRCUIT: 20C91A, (56289)		EA	1									3-39 A8A348C179	
X1-D		CAPACITOR, FIXED, CIRCUIT: 658083; (56289)		EA	4									3-39 A8A3E8,166	
X1-D		CAPACITOR, FIXED, CERAMIC: 6S8083; (56289)		EA	REF									3-39 A8A3E48C171	
X1-D		CAPACITOR, FIXED, CERAMIC: 6S8083; (56289)		EA	REF									3-39 A8A3E48C173	
X1-D		CAPACITOR, FIXED, CERAMIC: 6S8083, (56289)		EA	REF									3-39 A8A3E48C182	
X1-D		CAPACITOR, FIXED, ELECTROLYTIC. 150DIOX0035A2, (56289)		EA	2									3-39 ASA3E48C175	
X1-D		CAPACITOR, FIXED, EILCTROLYTIC. 150D100X0035A2, (56289)		EA	REF									3-39 A8A3ES8C185	
X1I-D		CAPACITOR, FIXED, MICA: CMD5ED750co3; (813J9)		EA	2									3-39 A8A3E48C169	
X1-D		CAPACITOR, FIXED, MICA: CM05ED750O03, (81349)		EA	RKF									3-39 A8A3E48C184	
X1-D		CAPACITOR, FIXED, MICA: CM05ED820Jo3; (81349)		EA	2									3-39 A8A3E48C162	
X1-D		CAPACITOR, FIXED, MICA: CMD5ED820Jo3; (81349)		EA	REF									3-39 A8A3E48C174	
X1-D		CAPACITOR, FIXED, MICA: CMD5FD121c03; (81349)		EA	1									3-39 ASA3E48C168-	
X1-D		CAPACITOR, FIXED, MICA: CM05FD131C03; (813&9)		EA	1									3-39 A8A3E48C168	
X1-D		CAPACITOR, FIXED, MICA: CMD5FD151C03, (813&9)		EA	1									3-39 A8A3E48C168	

* SELECT PER OPERATIONAL EQUIPMENT-

SECTION II

TM 11-5820-509-35

****REPAIR PARTS FOR DIRECT SUPPORT, GENERAL SUPPORT, AND DEPOT MAINTENANCE (continued)****															
(1) SMR CODE	(2) FEDERAL STOCK NUMBER	(3) DESCRIPTION Reference Number & Mfr. Code Usable on Code		(4) UNIT OF MEAS	(5) QTY INC IN UNIT	(6) 30 DAY DS MAINTENANCE ALLOWANCE			(7) 30 DAY GS MAINTENANCE ALLOWANCE			(8) 1 YR ALW PER 100 EQUIP CNTGCT	(9) DEPOT MAINT ALW PER 100 EQUIP	(10) ILLUSTRATION	
						(a)	(b)	(c)	(a)	(b)	(c)			(a) FIG NO.	(b) ITEM NO. OR REFERENCE DESIGNATION
						1-20	21-50	51-100	1-20	21-50	51-100				
X1-D		CAPACITOR, FIXED, MICA CM05FD161GO3, (81349)		EA	1									3-39	A8A3E48C168
X1-D		CAPACITOR, FIXED, MICA CM05FD221GO3; (81349)		EA	3									3-39	ASA3Eh8C167
X1-D		CAPACITOR, FIXED, MICA- CM05FD221GO3, (81349)		EA	REF									3-39	ASA3E48c170
X1-D		CAPACITOR, FIXED, MICA. CM05FD221GO3, (81349)		EA	REF									3-39	A8A3Eh8CIT2
X1-D		CAPACITOR, FIXED, MICA: DM15F471J300WV4CR, (72136)		EA	3									3-39	ASA3E48C163
X1-D		CAPACITOR, FIXED, MICA DM15F471J300WV4CR, (72136)		EA	REF									3-39	ASA3E48c16h
X1-D		CAPACITOR, FIXED, MICA. DK5F471J300WV4CR; (72136)		EA	REF									3-39	ASA3E48cl86
X1-D		CAPACITOR, FIXED, MICA: DM15F1330F0500WV4 CR, (72136)		EA	1									3-39	AA3E,48c168
X1-D		CAPACITOR, FIXED, MICA- DM15E141F0500WV4CR, (72136)		EA	1									3-39	A8A3zE8c168
X1-D		CAPACITOR, FIXED, MICA: DM15E1270F0500WV4CR		EA	1									3-39	ASA3E8C1i68
X1-D		COIL, RADIO FREQUENCY LT0IK020, (81349)		EA	1									3-39	A8A3E48L101
X1-D		COIL, RADIO FREQUENCY- LT10K029, (81349)		EA	1									3-39	AA03E48L100
X1-D		RESISTOR, FIXED, COMPOSITION RCR07G560KS; (81349)		EA	1									3-39	ABA3EH8R190
X1-D		DRESISTOR, FIXED, COMPOSITION RCR07G121KS, (81349)		EA	2									3-39	A8A3E48R77
X1-D		RESISTOR, FIXED, COWOSITION RCR07G121KS, (81349)		EA	REF									3-39	A\$A3E48R94
X1-D		RESISTOR, FIXED, COMPOSITION: RCR07CG71KS; (81340)		EA	1									3-39	A8A3E48R58
X1-D		RESISTOR, FIXED, COMPOSITION RCR07C102KS, (81 349)		EA	3									3-39	ASA3E48R59
X1-D		RESISTOR, FIXED, COMPOSITION RCR07G102KS, (81349)		EA	REF									3-39	A8A3E48R89
X1-D		RESISTOR, FIXED, COMPOSITION. RCR07G102KS; (81349)		EA	REF									3-39	A8A3E48R90
X1-D		RESISTOR, FIXED, COMPOSITIOD- RCR07G222KS, (81349)		EA	1									3-39	ASA3E48R91
X1-D		RESISTOR, FIXED, COMPOSITION- RCR07G272KS, (81349)		EA	1									3-39	A8A3E48R67
X1-D		RESISTOR, FIXED, COMPOSITION- RCR07CG72KS, (81349)		EA	1									3-39	AkA3E48R66
X1-D		RESISTOR, FIXED, COMPOSITION RCR07G682KS; (81349)		EA	2									3-39	ASA3E48R64
X1-D		RESISTOR, FIXED, COBMPOSITION RCR07C682KS, (81349)		EA	REF									3-39	A8A3E48R70

* SELECT PER OPERATIONAL EQUIPMENT

SECTION II

TM 11-5820-509-35

****REPAIR PARTS FOR DIRECT SUPPORT, GENERAL SUPPORT, AND DEPOT MAINTENANCE (continued)****															
(1) SMR CODE	(2) FEDERAL STOCK NUMBER	(3) DESCRIPTION Reference Number & Mfr. Code Usable on Code		(4) UNIT OF MEAS	(5) QTY INC IN UNIT	(6) 30 DAY DS MAINTENANCE ALLOWANCE			(7) 30 DAY GS MAINTENANCE ALLOWANCE			(8) 1 YR ALW PER 100 EQUIP CNTGCTY	(9) DEPOT MAINT ALW PER 100 EQUIP	(10) ILLUSTRATION	
						(a)	(b)	(c)	(a)	(b)	(c)			(a) FIG NO.	(b) ITEM NO. OR REFERENCE DESIGNATION
						1-20	21-50	51-100	1-20	21-50	51-100				
X1-D		RESISTOR, FIXED, COMPOSITION RCR07G822KS, (81349)		EA	3									3-39	A8A3E48R63
X1-D		RESISTOR, FIXED, COMPOSITION RCR07G822KS, (81349)		EA	REF									3-39	ABA3E48R69
X1-D		RESISTOR, FIXED, COMPOSITION- RCR07G822Ks; (81349)		EA	REF									3-39	A8A3E48R87
X1-D		RESISTOR, FIXED, COMPOSITION RCR07G103KS, (81349)		EA	1									3-39	A8A3E48R97
X1-D		RESISTOR, FIXED, COMPOSITION. RCR7G183XS, (81349)		EA	1									3-39	A8A3E48R92
X1-D		RESISTOR, FIXED, COMPOSITION RCR07G223KS, (81349)		EA	1									3-39	A8A3E48R93
X1-D		RESISTOR, FIXED, COMPOSITION: RCR07G333KS, (81349)		EA	3									3-39	A8A3E48R62
X1-D		RESISTOR, FIXED, COWMK)STION- RCR07G333KS, (81349)		EA	REF									3-39	ABA3E48R68
X1-D		RESISTOR, FIXED, COMPOSITION- RCR07G333KS, (81349)		EA	REF									3-39	A8A3E48R72
X1-D		RESISTOR, FIXED, COMPOSITION- RCR07G473KS; (81349)		EA	2									3-39	A8A3E48R61
X1-D		RESISTOR, FIXED, COMPOSITION RCR07G473KS; (81349)		EA	REF									3-39	ABA3E48R71
X1-D		RESISTOR, FIXED, COMPOSITION- RCR07G683KS; (81349)		EA	1									3-39	A8A3E48R65
X1-D		RESISTOR, FIXED, COMPOSITION. RCR07G474KS, (81349)		EA	4									3-39	A8A3E48R78
X1-D		RESISTOR, FIXED, COMPOSITION. RCR07G474KS; (81349)		EA	REF									3-39	A8A3E48R79
X1-D		RESISTOR, FIXED, COMPOSITION- RCR7CG474KS; (81349)		EA	REF									3-39	A8A3E48R80
XC-D		RESISTOR, FIXED, COMPOSITION RCR07G474Ks; (81349)		EA	REF									3-39	A8A3E48R81
X1-D		RESISTOR, FIXED, FILM RN60D75ROF, (81349)		EA	2									3-39	A8A3E48RL46
X1-D		RESISTOR, FIXED, FILM- RN60DTSROF, (81349)		EA	REF									3-39	A8A3E48RL47
X1-D		RESISTOR, VARIABLE, WIREWOUND- 224L1-201, (80294)		EA	1									3-39	A8A3E48RI15
X1-D		NUT, PLAIN, EEXAGON: MS3569g-225; (96906)		EA	2									3-39	A8A3E48R1501H
X1-D		NUT, PLAIN, HEXAGON MS35649-225, (96906)		EA	REF										A8A3E48RI50H2
X1-D		SCREW, MACHINE. NS51957-5, (96906)		EA	2								3-39	A8A3E48R150h3	
X1-D		SCREW, MACHINE- MS51957-5, (96906)		EA	REF										A8A3E48RI50cH
X1-D		WASHER, FLAT 310-6320-00, (79807)		EA	2										A8A3E48RI50H5
X1-D		WASHER, FLAT 310-6320-00, (79807)		EA	REF										A8A3E48R150H6

SECTION II

TM 11-5820-509-35

****REPAIR PARTS FOR DIRECT SUPPORT, GENERAL SUPPORT, AND DEPOT MAINTENANCE (continued)****															
(1) SMR CODE	(2) FEDERAL STOCK NUMBER	(3) DESCRIPTION Reference Number & Mfr. Code Usable on Code		(4) UNIT OF MEAS	(5) QTY INC IN UNIT	(6) 30 DAY DS MAINTENANCE ALLOWANCE			(7) 30 DAY GS MAINTENANCE ALLOWANCE			(8) 1 YR ALW PER 100 EQUIP CNTGCTY	(9) DEPOT MAINT ALW PER 100 EQUIP	(10) ILLUSTRATION	
						(a)	(b)	(c)	(a)	(b)	(c)			(a) FIG NO.	(b) ITEM NO. OR REFERENCE DESIGNATION
						1-20	21-50	51-100	1-20	21-50	51-100				
X1-D		RESISTOR, VARIABLE, WIRE WOUND- 224L1-503, (80294)	EA	1										3-39	A8A3E48R148
X1-D		NUT, PLAIN, HEXAGON MS356h9-225, (96906)	EA	2										3-39	A8A3E48R148HI
X1-D		NUT, PLAIN, HEXAGON MS35649-225; (96906)	EA	REF											A8A3E48R148H2
X1-D		SCREW, MACHINE- MS51957-5, (96906)	EA	2											A8A3E18R148H3
X1-D		SCREW, MACHINE WS51957-5, (96906)	EA	REF											A8A3E48R148H4
X1-D		WASHER, FLAT 310-6320-00, (79807)	EA	2											A8A3E48R148H5
X1-D		WASHER, FLAT 310-6320-00; (79807)	EA	REF											A8A3E48Rih8SH6
X1-D		SEMICOINDUCTOR DEVICE, DIODE INB98, (07688)	EA	2										3-39	A8A3E48CR3
X1-D		SEMICONDUCTOR DEVICE, DIODE: 1N198; (07688)	EA	REF										3-39	A8A3E48CR8
X1-D		SEMICONDUCTOR DEVICE, DIODE- 1N916; (07688)	EA	1										3-39	A8A3E48CR2
X1-D		TRANSFORMER, RADIO FREQUENCY- 549-6002-003; (13499)	EA	1										3-39	A8A3E48T1
X1-D		TRANSISTOR. 2N703, (07688)	EA	4										3-39	ABA3E48Q9
X1-D		TRANSISTOR 2N703, (07688)	EA	REF										3-39	A8A3E48Q1Q
X1-D		TRANSISTOR 2N703, (07688)	EA	REF										3-39	A8A3E48QI4
X1-D		TRANSISTOR: 2703, (07688)	EA	REF										3-39	A8A3E48QI5
X1-D		TRANSISTOR- MS2181, (04713)	EA	1										3-39	AnA3ES48Qi
P-D	5310-158-5227	NUT, GUIDE. 553-9748-002, (13499)	EA	2								*	*		A8A3MP16
P-D	5305-05h-5638	SCREW, MACHINE MS51957-4; (96906)	EA	1								*	*		A8A3MP16H1
P-D 3		WASHER, FLAT 10-6320-00, (79807)	EA	1								*	*		A8A3MP16H2
P-D		NUT, GUIDE 553-9748-002, (13499)	EA	REF								REF	REF		A8A3MP17
P-D	5305-054-5638	SCREW, MACHINE- MS51957-4, (96906)	EA	1								REF	REF		A8A3MP17H1
P-D		WASHER, FLAT 310-6320-00, (79807)	EA	1								REF	REF		A8A3MP17H2
P-D	5310-952-1h23	NUT, PLAJN, HEXAGON P313-0143-000; (77250)	EA	6								*	*		A8A3H3
P-D	5310-952-1423	NUT, PLAIN, HEXAGON P313-01 b3-000, (77250)	EA	REF								REF	REF		A8A3H4
P-D	5310-952-1423-	NUT, PLAIN, HEXAGON P313-0143-000, (77250)	EA	REF								REF	REF		A8A3H5

SECTION II

TM 11-5820-509-35

****REPAIR PARTS FOR DIRECT SUPPORT, GENERAL SUPPORT, AND DEPOT MAINTENANCE (continued)****															
(1) SMR CODE	(2) FEDERAL STOCK NUMBER	(3) DESCRIPTION Reference Number & Mfr. Code Usable on Code		(4) UNIT OF MEAS	(5) QTY INC IN UNIT	(6) 30 DAY DS MAINTENANCE ALLOWANCE			(7) 30 DAY GS MAINTENANCE ALLOWANCE			(8) 1 YR ALW PER 100 EQUIP CNTGCTY	(9) DEPOT MAINT ALW PER 100 EQUIP	(10) ILLUSTRATION	
						(a) 1-20	(b) 21-50	(c) 51-100	(a) 1-20	(b) 21-50	(c) 51-100			(a) FIG NO.	(b) ITEM NO. OR REFERENCE DESIGNATION
P-D	5310-952-1423	NUT, PLAIN, HEXAGON P313-014 3-000, (77250)		EA	REF							REF	REF		A8A3H6
P-D	5310-952-1423	NUT, PLA1N, HEXAGON P313-0143-000, (77250)		EA	REF							REF	REF		A8A3H7
P-D	5310-952-1423	NUT, PLAIN, HEXAGON P313-01L3-000, (77250)		EA	REF							REF	REF		A8A3H8
P-H-T	5820-960-7852	OSCILLATOR SUBASSEMBLY 5L8-7794-005, (13499)		EA	1				*	*	*	*	*	3-9	A8A3A4
P-D	5310-622-1724	NUT, SELF-LOCKING, HEXAGON 68-1660-26, (72962)		EA	1							REF	REF		A8A3A4H1
P-D	5305-054-5638	SCREW, MACHINE MS51957-4, (96906)		EA	1							REF	REF		A8A3A4H1
P-D	5305-059-8228	SCREW, MACHINE P343-0299-000, (77250)		EA	2							REF	REF		A8A3A4H2
P-D		WASHER, FLAT 310-0053-000; (79807)		EA	2							REF	REF		A8A3A4H2
P-D	5310-907-0459	WASHER, FLAT 310-6320-00,		EA (79807)	1							REF	REF		A8A3A4H1
P-D	5310-818-6245	WASHER, FLAT 504-0726-003, (13499)		EA	1							*	*		A8A3A4H1
P-D	5310-043-2149	WASHER, FLAT 546-3043-003, (13499)		EA	1							*	*		A8A3A4H1
P-D	5310-680-5557	WASHER, SPRING TENSION 310-000075-00, (79807)		EA	1							REF	REF		A8A3ALH1
X1-D		BOARD, PRINTED CIRCUIT- 548-7799-005,		EA (13499)	1									3-33	A8A3AIE6
X1-D		BOARD, PRINTED CIRCUIT 548-7802-004, (13499)		EA	1									3-34	A8A3A4E7
P-D	5910-244-1622	CAPACITOR, FIXED, CERAMIC TC50-83; (09052)		EA	1							*	*	3-33	A8A3A4C338
P-D	5910-685-9692	CAPACITOR, FIXED, CERAMIC CK13BX103M, (81349)		EA	6							REF	REF	3-33	A8A3A4C318
P-D	5910-685-9692	CAPACITOR, FIXED, CERAMIC CK13BX103M, (81349)		EA	REF							REF	REF	3-33	A8A3A4C319
P-D	5910-685-9692	CAPACITOR, FIXED, CERAMIC CK13BX103M, (81349)		EA	REF							REF	REF	3-34	A8A3A4C334
P-D	5910-685-9692	CAPACITOR, FIXED, CERAMIC CK13BX103M, (81349)		EA	REF							REF	REF	3-33	A8A3A4C335
P-D	5910-685-9692	CAPACITOR, FIXED, CERAMIC CK13BX103M, (81349)		EA	REF							REF	REF	3-33	A8A3A4C336
P-D	5910-685-9692	CAPACITOR, FIXED, CERAMIC CK13BX103M, (81349)		EA	REF							REF	REF	3-33	A8A3ALC3h3
P-D		CAPACITOR, FIXED, ELECTROLYTIC 150D154XCO35A2, (56289)		EA	2							*	*	3-34	A8A3A4C331
P-D		CAPACITOR, FIXED, ELECTROLYTIC 150D154XCO35A2, (56289)		EA	REF							REF	REF	3-34	ABA3A4C332
P-D		CAPACITOR, FIXED, MICA. DM15F511G301DOv4CR, (72136)		EA	2							*	*	3-34	A8A3A4C330
P-D		CAPACITOR, FIXED, MICA: DM15F511CG30WV4CR, (72136)		EA	REF							REF	REF	3-34	A8A3A4C333

SECTION II

TM 11-5820-509-35

****REPAIR PARTS FOR DIRECT SUPPORT, GENERAL SUPPORT, AND DEPOT MAINTENANCE (continued)****															
(1) SMR CODE	(2) FEDERAL STOCK NUMBER	(3) DESCRIPTION Reference Number & Mfr. Code Usable on Code		(4) UNIT OF MEAS	(5) QTY INC IN UNIT	(6) 30 DAY DS MAINTENANCE ALLOWANCE			(7) 30 DAY GS MAINTENANCE ALLOWANCE			(8) 1 YR ALW PER 100 EQUIP CNTGCTY	(9) DEPOT MAINT ALW PER 100 EQUIP	(10) ILLUSTRATION	
						(a) 1-20	(b) 21-50	(c) 51-100	(a) 1-20	(b) 21-50	(c) 51-100			(a) FIG NO.	(b) ITEM NO. OR REFERENCE DESIGNATION
P-D	5910-764-275e	CAPACITOR, FIXED, MICA CM04ED050D03, (81349)		EA	1							*	*	3-33	A8A3AbC341
P-D	5910-089-7504	CAPACITOR, FIXED, MICA CM04ED100D03, (81349)		EA	1							*	*	3-33	A8A3A4C339
P-D		CAPACITOR, FIXED, MICA CM04ED360G03, (81349)		EA	2							*	*	3-34	A8A3A4C329
P-D		CAPACITOR, FIXED, MICA CM04ED360G03, (81349)		EA	REF							REF	REF	3-33	ABA3A4C345
P-D	5910-891-7266	CAPACITOR, FIXED, MICA CM04ED430G03, (81349)		EA	1							*	*	3-34	A8A3A4C328
P-D	5910-064-4697	CAPACITOR, FIXED, MICA CM04ED470G03, (81349)		EA	1							*	*	3-34	ABA3A4C327
P-D	5910-107-2682	CAPACITOR, FIXED, MICA' CM04ED62F0F3; (81349)		EA	2							*	*	3-3	A8A3A4C325
P-D	5910-107-2682	CAPACITOR, FIXED, MICA CM04ED620FO3, (81349)		EA	REF							REF	REF	3-34	A8A3A4C326
P-D	5910-960-7298	CAPACITOR, FIXED, MICA CK04ED680Fo3; (81349)		EA	1							*	*	3-34	A8A3A4C340
P-D	5910-960-7299	CAPACITOR, FIXED, MICA CM04ED820FO3, (81349)		EA	1							*	*	3-34	A&A3A4C324
P-D	5910-829-3372	CAPACITOR, FIXED, MICA. CM04FDIIIIF03, (81349)		EA	1							*	*	3-33	A8A3A4C337
P-D	5910-829-3371	CAPACITOR, FIXED, MICA- CM04FD121F03, (81349)		EA	1							*	*	3-34	A8A3A4C323
P-D	5910-078-2024	CAPACITOR, FIXED, MICA CM04FD151F03, (81349)		EA	1							*	*	3-34	A8A3A4C322
P-D	5910-069-0376	CAPACITOR, FIXED, MICA CM04FD241F03, (81349)		EA	1							*	*	3-34	A8A3A4C321
P-D	5910-118-7937	CAPACITOR, FIXED, MICA CM04FA331F03, (81349)		EA	1							*	*	3-34	A8A3A4C349
P-D	5910-830-4910	CAPACITOR, FIXED, MICA' CM04FA361FO3, (81349)		EA	1							*	*	3-34	A8A3A4C320
P-D	5961-960-7835	SEMICONDUCTOR DEVICE, DIODE- V499, (01281)		EA	2							*	*	3-3	A8A3A4CR9
P-D	5961-960-7835	SEMICONDUCTOR DEVICE, DIODE' V499, (01281)		EA	REF							REF	REF	3-34	A8A3A4CR10
P-H-T		COIL ASSEMBLY, RADIO FREQUENCY 5L8-7793-004, (13499)		EA	1				*	*	*	*	*	3-33	A8A3AA1
P-D	5310-622-1724	NUT, SELF-LOCKING, REXAGON. 68-1660-26, (72962)		EA	4							REF	REF		A8A3A4A1H4
P-D	5305-727-8883	SCREW, MACHINE MS51959-3, (96906)		EA	4							REF	REF		A8A3A4AiH4
X1-D		CAPACITOR, FIXED, MICA DH1OC020DO, (1L655)		EA	5									3-31	A8A3AhA1C305
X1-D		CAPACITOR, FIXED, MICA DMIOCO20DO, (14655)		EA	REF									3-31	A8A3A14AC307
X1-D		CAPACITOR, FIXED, MICA: DM1OC020DO, (14655)		EA	REF									3-31	A8A3A4AIC309 *
X1-D		CAPACITOR, FIXED, MICA DM10CO20DO, (114655)		EA	REF									3-31	ABA3A4A1C311 *

* SELECT PER OPERATIONAL EQUIPMENT.

SECTION II

TM 11-5820-509-35

****REPAIR PARTS FOR DIRECT SUPPORT, GENERAL SUPPORT, AND DEPOT MAINTENANCE (continued)****															
(1) SMR CODE	(2) FEDERAL STOCK NUMBER	(3) DESCRIPTION Reference Number & Mfr. Code Usable on Code		(4) UNIT OF MEAS	(5) QTY INC IN UNIT	(6) 30 DAY DS MAINTENANCE ALLOWANCE			(7) 30 DAY GS MAINTENANCE ALLOWANCE			(8) 1 YR ALW PER 100 EQUIP CNTGCTY	(9) DEPOT MAINT ALW PER 100 EQUIP	(10) ILLUSTRATION	
						(a)	(b)	(c)	(a)	(b)	(c)			(a) FIG NO.	(b) ITEM NO. OR REFERENCE DESIGNATION
						1-20	21-50	51-100	1-20	21-50	51-100				
X1-D		CAPACITOR, FIXED, MICA DM10C020DO, (14655)		EA	REF									3-31	A8A3A4AIC313 .
X1-D		CAPACITOR, FIXED, MICA CM04CD120J03, (81349)		EA	5									3-31	A8A3A4AIC305 .
X1-D		CAPACITOR, FIXED, MICA' CM04CD120J03, (81349)		EA	REF									3-31	A8A3A4A1C307 .
X1-D		CAPACITOR, FIXED, MICA CM04CD120J03, (81349)		EA	REF									3-31	A8A3A4A1C309 -
X1-D		CAPACITOR, FTXED, MICA CM04CD120J03, (81349)		EA	REF									3-31	A8A3A4A1C311 .
X1-D		CAPACITOR, FIXED, MICA. CM04CD120J03, (81349)		EA	REF									3-31	A8A3A4A1C313 I
X1-D		CAPACITOR, FIXED, MICA. CM04CD150J03, (81349)		EA	5									3-31	A8A3A4AIC305 .
X1-D		CAPACITOR, FIXED, MCA CM04CD150J03, (81349)		EA	REF									3-31	A8A3A4AIC307 .
X1-D		CAPACITOR, FIXED, MICA CM04CD150J03, (81349)		EA	REF									3-31	A8A3A4AIC309 -
X1-D		CAPACITOR, FIXED, MICA CM04CD150J03; (81349)		EA	REF									3-31	A8A3A4AIC311 -
X1-D		CAPACITOR, FIXED, MICA- CM04CD15W0J3, (81349)		EA	REF									3-31	A8A3A4A1C313 .
X1-D		CAPACITOR, FIXED, MICA CM04ED220J03, (81349)		EA	5									3-31	A8A3Ah4AC305 .
X1-D		CAPACITOR, FIXED, MICA CM04ED220J03, (81349)		EA	REF									3-31	A8A3A4AIC307 .
X1-D		CAPACITOR, FIXED, MICA: CM04ED220J03, (81349)		EA	REF									3-31	A8A3A4AIC309 '
X1-D		CAPACITOR, FIXED, MICA: CM04ED220J03, (81349)		EA	REF									3-31	A8A3A4AIC311
X1-D		CAPACITOR, FIXED, MICA' CM04ED220J03, (81349)		EA	REF									3-31	A8A3A4AIC313
X1-D		CAPACITOR, FIXED, MICA CM04ED270G03, (81349)		EA	5									3-31	A8A3A4AIC305 .
X1-D		CAPACITOR, FIXED, MICA CM04ED270G03, (81349)		EA	REF									3-31	A8A3A4AIC307 *
X1-D		CAPACITOR, FIXED, MICA. CM04ED270Go3, (81349)		EA	REF									3-31	A8A3A4AIC309
X1-D		CAPACITOR, FHXED, MICA CM04ED270G03, (81349)		EA	REF									3-31	A8A3A4AIC311
X1-D		CAPACITOR, FIXED, MICA CM04ED270G03, (81349)		EA	REF									3-31	A8A3A4AIC313 .
X1-D		CAPACITOR, FIXED, MICA CM04ED300OG3, (81349)		EA	1									3-31	A8A3A4AIC312
X1-D		CAPACITOR, FIXED, MICA CK04ED390G03, (81349)		EA	5									3-31	A8A3A4AIC305 .
X1-D		CAPACITOR, FIXED, MICA CM04ED390G03, (81349)		EA	REF									3-31	A8A3A4AIC307 .
X1-D		CAPACITOR, FIXED, MICA CM04ED390Go3, (81349)		EA	REF									3-31	A8A3A4A1C309 -

* SELECT PER OPERATIONAL REQUIREMENT

SECTION II

TM 11-5820-509-35

****REPAIR PARTS FOR DIRECT SUPPORT, GENERAL SUPPORT, AND DEPOT MAINTENANCE (continued)****															
(1) SMR CODE	(2) FEDERAL STOCK NUMBER	(3) DESCRIPTION Reference Number & Mfr. Code Usable on Code		(4) UNIT OF MEAS	(5) QTY INC IN UNIT	(6) 30 DAY DS MAINTENANCE ALLOWANCE			(7) 30 DAY GS MAINTENANCE ALLOWANCE			(8) 1 YR ALW PER 100 EQUIP CNTGCTY	(9) DEPOT MAINT ALW PER 100 EQUIP	(10) ILLUSTRATION	
						(a)	(b)	(c)	(a)	(b)	(c)			(a) FIG NO.	(b) ITEM NO. OR REFERENCE DESIGNATION
						1-20	21-50	51-100	1-20	21-50	51-100				
XI-D		CAPACITOR, FIXED, MICA: CD04ED390G03, (81349)		EA	RE									3-31	A8A3A4AIC311 -
X1-D		CAPACITOR, FIXED, MICA: CM04ED390G03; (81349)		EA	REF									3-31	A8A3A4A1C313 *
XI-D		CAPACITOR, FIXED, MICA: CM04ED430G03, (81349)		EA	1									3-31	A8A3AhAIC310
X1-D		CAPACITOR, FIXED, MICA. CM04ED510F03, (81349)		EA	5									3-31	A8A3A4AIC305 .
XI-D		CAPACITOR, FIXED, MICA- CM04ED51F03; (81349)		EA	REF									3-31	A8A3A4AiC307 .
X1-D		CAPACITOR, FIXED, MICA. CM04ED510F03; (81349)		EA	REF									3-31	A8A3A4AIC309 .
X1-D		CAPACITOR, FIXED, MICA CM04ED51CF03, (81349)		EA	REF									3-31	A8A3A4AIC311 -
X1-D		CAPACITOR, FIXED, MICA. CM04ED510F03; (81349)		EA	REF									3-31	A8A3A4A1C313 '
X1-D		CAPACITOR, FIXED, K[CA' CM04ED620F03, (81349)		EA	1									3-31	A8A3A4AIC308
X1-D		CAPACITOR, FIXED, MICA: CM04FD101F03, (81349)		EA	2									3-31	A8A3A4AIC3O4
X1-D		CAPACITOR, FIXED, MICA: CM04FD101F03; (81349)		EA	RF									3-31	A8A3A4AIC306
X1-D		CHANNEL, COIL MDUWTINC- 548-7789-003, (13499)		EA	1										A8A3A4ALUP1
X1-D		COIL, RADIO FREQUENCY-NO. 1 548-7805-004, (13499)		EA	1									3-31	A8A3A4A1L125
X1-D		NUT, PLAIN, HEXAGON. 334-1290-000; (13499)		EA	1										A8A3A4AIL125H1
X1-D		WASHER, SPRING TENSION 310-0397-00, (79807)		EA	1										A8A3A4AIL125H2
X1-D		COIL, RADIO FREQUENCY-NO. 2: 548-7807-004; (13499)		EA	2									3-31	A8A3A4AIL126
X1-D		NUT, PLAIN, HEXAGON 334-1290-000, (13499)		EA	1										A8A3A4AL126H1
X1-D		WASKER, SPRING TENSION 310-0397-00, (79807)		EA	1										A8A3A4A1L126H2
X1-D		COIL, RADIO FREQUENCY-NO. 2- 548-7807-004, (13499)		EA	REF									3-31	A8A3A4A1L142
X1-D		NUT, PLAIN, HEXAGON 334-1290-000, (13499)		EA	1										A8A3A4AIL142H2
X1-D		WASHER, SPRING TENSION 310-0397-00; (79807)		EA	1										A8A3A4A1L142HI
X1-D		COIL, RADIO FREQUENCY-NO. 4: 548-7808-004, (13499)		EA	3									3-31	A8A3AI4AL127
X1-D		NUT, PLAIN, HEXAGON 334-1290-000, (13499)		EA	1										A8A3A4AIL127H1
X1-D		WASHER, SPRING TENSION 310-0397-00, (79807)		EA	1										A8A3A4AIL127H2
X1-D		COIL, RADIO FREQUENCY-NO. 4 548-7808-004, (13499)		EA	REF									3-31	A8A3A4A1L133

* SELECT PER OPERATIONAL REQUIREMENT.

****REPAIR PARTS FOR DIRECT SUPPORT, GENERAL SUPPORT, AND DEPOT MAINTENANCE (continued)****															
(1) SMR CODE	(2) FEDERAL STOCK NUMBER	(3) DESCRIPTION Reference Number & Mfr. Code Usable on Code		(4) UNIT OF MEAS	(5) QTY INC IN UNIT	(6) 30 DAY DS MAINTENANCE ALLOWANCE			(7) 30 DAY GS MAINTENANCE ALLOWANCE			(8) 1 YR ALW PER 100 EQUIP CNTGCT	(9) DEPOT MAINT ALW PER 100 EQUIP	(10) ILLUSTRATION	
						(a)	(b)	(c)	(a)	(b)	(c)			(a) FIG NO.	(b) ITEM NO. OR REFERENCE DESIGNATION
						1-20	21-50	51-100	1-20	21-50	51-100				
X1-D		NUT, PLAIN, HEXAGON 334-1290000; (13499)		EA	1										A8A3A4A1L133H1
X1-D		WASHER, SPRING, TENSION: 310-0397-00; (79807)		EA	1										ABA3A1LJ 332
X1-D		COIL, RADIO, FREQUENCY-NO. 4 548-7808-004; (13499)		EA	REF								3-31		AA3AhA1L134
X1-D		NUT, PLAIN, HEXAGON: 334-1290-000; (1399)		EA	1										A8A3A4AL134HI
X1-D		WASHER, SPRING TENSION: 310-03970; (79807)		EA	1										AA3AhA1L134H2
X1-D		COIL, RADIO FREQUENCY-NO. 5: 548-7809-004; (13k99)		EA	1								3-31		A:8A3A4A1L41
X1-D		NUT, PLAIN, HEXAGON: 334-129 000; (13499)		EA	1										A8A3A4A1LL14111
X1-D		WASHER, SPRING TENSION: 310-0397-00; (79807)		EA	1										A8A3A4AL14LIH2
X1-D		COIL, RADIO, FREQUENCY-NO. 6: 54B-7810-004; (13499)		EA	1									3-41	ABA3A4AiL1L4
X1-D		NUT, PLAIN, HEXAGON. 334-1290-000; (13h99)		EA	1										A8A3A4A1LL4bOH
X1-D		WASKER, SPRING, TENSION: 310-0397-0; (79807)		EA	1										AA3A4A1L140H2
X1-D		COIL, RADIO FREQUENCY-NO. 7: 548-7811-0; (13499)		EA	1									3-31	A8A3A4AL139
X1-D		NUT, PLAIN, HEXAGON: 334-1290-000; (13h99)		EA	1										A8A3A4AtL39H1
X1-D		WASHER, SPRING TENSION 310-0397-00; (79&O7)		EA	1										A8A3A4AiL13392
X1-D		COIL, RADIO, FREQUENCY-NO. 8: 548-T812-000, (13499)		EA	1									3-31	3A4A L138
X1-D		NUT, PLAIN, HEXADON: 334129002; (13499)		EA	1										A8A3A4A1L138H11
X1-D		WASHER, SPRING TENSION: 31-00397-00; (79807)		EA	1										A8A3AI4AL138H2
X1-D		RESISTOR, FIXED, COMPOSITION:: R5CGn332K; (813h9)		EA	3									3-31	A8A3A4AIR175
X1-D		RESISTOR, FIXED, COMPOSITION: RC05Gsn3, (813h9)		EA	REF									3-31	A8A3A(AKR176
X1-D		RESISTOR, FIXED, COMPOSTION:: RC050(332, (81349)		EA	REF									3-31	A8A3A4AIR177
X1-D		RESISTOR, FIXED, COMPOSITION: RC05GG39; (81319)		EA	1									3-31	A8A3A4AiR178
X1-D		RESISTOR, FIXED, COMPOSITION:: RC05G969K; (81349)		EA	1									3-31	AA3AhAR174
X1-D		TERMINAL, LUG: 407-8HT; (77147)		EA	3										A8A3A4AIE1
X1-D		TERMAL, LUG: 4007-8HT; (77147)		EA	REF										AA3AAIGE2
X1-D		TERMINAL, LUG: 4007-8HT, (77147)		EA	REF										A8A3A4AIE3

SECTION II

TM 11-5820-509-35

****REPAIR PARTS FOR DIRECT SUPPORT, GENERAL SUPPORT, AND DEPOT MAINTENANCE (continued)****																
(1) SMR CODE	(2) FEDERAL STOCK NUMBER	(3) DESCRIPTION Reference Number & Mfr. Code Usable on Code		(4) UNIT OF MEAS	(5) QTY INC IN UNIT	(6) 30 DAY DS MAINTENANCE ALLOWANCE			(7) 30 DAY GS MAINTENANCE ALLOWANCE			(8) 1 YR ALW PER 100 EQUIP CNTGCTY	(9) DEPOT MAINT ALW PER 100 EQUIP	(10) ILLUSTRATION		
						(a) 1-20	(b) 21-50	(c) 51-100	(a) 1-20	(b) 21-50	(c) 51-100			(a) FIG NO.	(b) ITEM NO. OR REFERENCE DESIGNATION	
X1-D		TERMINAL, LUG 5148-7800-002, (13499)		EA	5											A8A3A4A1E4
X1-D		TERMINAL, LUG 548-7800-002, (13499)		EA	REF											A8A3A4A1E5
X1-D		TERMINAL, LUG- 548-7800-002, (13499)		EA	REF											A8A3A4A1E6
X1-D		TERMINAL, LUG 548-7800-002, (13499)		EA	REF											A8A3A4A1E7
X1-D		TERMINAL, LUG 548-7800-002, (13499)		EA	REF											A8A3A4A1E8
X1-D		TERMINAL, STUD AB397-1A, (12615)		EA	4											A8A3A4A1E9
X1-D		WASHER, SPRING TENSION- 310-0075-00, (79807)		EA	1											A8A3A4A1E9H1
X1-D		TERMINAL, STUD AB397-1A, (12615)		EA	REF											A8A3AA1E3 O
X1-D		WASHER, SPRING TENSION' 310-0075-00, (79807)		EA	1											A8A3A1A1EIOH1
X1-D		TERMINAL, STUD AB397-1A, (12615)		EA	REF											ABA3A4A1EII
X1-D		WASHER, SPRING TENSION 310-0075-oo, (79807)		EA	1											A8A3A4A1EIIIH1
X1-D		TERMINAL, STUD AB397-1A, (12615)		EA	REF											A8A3A4A1E12
X1-D		WASHER, SPRING TENSION 310-0075-00, (79807)		EA	1											A8A3A4A1E12H1
P-H-T	5950-960-7848	COIL ASSEMBLY, RADIO FREQUENCY 548-7795-005, (13499)		EA	1				*	*	*	*	*	3-33		A8A3A4A2
P-D		NUT, SELF-LOCKING, HEXAGON 68-1660-26, (72962)		EA	4							REF	REF			A8A3A4A2H4
P-D		SCREW, MACHINE MS51959-3, (96906)		EA	4							REF	REF			A8AB3AA2H4
X1-D		CAPACITOR, FIXED, MICA CM04CDo50DO3, (81349)		EA	5									3-32		A8A3AhA2C299
X1-D		CAPACITOR, FIXED, MICA CM04CDO50Do3, (81349)		EA	REF									3-32		A8A3A4A2C301 *
X1-D		CAPACITOR, FIXED, MICA CM04CDO50Do3, (81349)		EA	REF									3-32		A8A3A4A2C303 *
X1-D		CAPACITOR, FIXED, MICA- CM04CDo5oDo3, (81349)		EA	REF									3-32		A8A3A4A2C315 '
X1-D		CAPACITOR, FIXED, MICA- CM04CDO50DO3, (81349)		EA	REF									3-32		A8A3A4A2C317 #
X1-D		CAPACITOR, FIXED, MICA CM04CD150J03, (81349)		EA	6									3-32		A8A3AhA2C299 ^
X1-D		CAPACITOR, FIXED, MICA CM04CD150J03, (81349)		EA	REF									3-32		A8A3A4A2C301 *
X1-D		CAPACITOR, FIXED, MICA CM04CD150J03, (81349)		EA	REF									3-32		A8A3A4A2C303 *
X1-D		CAPACITOR, FIXED, MICA CM04CD150J03, (81349)		EA	REF									3-32		A8A3A4A2C315 *

* SELECT PER OPERATIONAL REQUIREMENT

SECTION II

TM 11-5820-509-35

REPAIR PARTS FOR DIRECT SUPPORT, GENERAL SUPPORT, AND DEPOT MAINTENANCE (Continued)															
(1) SMR CODE	(2) FEDERAL STOCK NUMBER	(3) DESCRIPTION Reference Number & Mfr. Code Usable on Code		(4) UNIT OF MEAS	(5) QTY INC IN UNIT	(6) 30 DAY DS MAINTENANCE ALLOWANCE			(7) 30 DAY GS MAINTENANCE ALLOWANCE			(8) 1 YR ALW PER 100 EQUIP CNTGCTY	(9) DEPOT MAINT ALW PER 100 EQUIP	(10) ILLUSTRATION	
						(a)	(b)	(c)	(a)	(b)	(c)			(a) FIG NO.	(b) ITEM NO. OR REFERENCE DESIGNATION
						1-20	21-50	51-100	1-20	21-50	51-100				
X1-D		CAPACITOR, FIXED, MICA: CM04CD150J03, (81349)		EA	REF									3-32	A8A3A4A2C316
X1-D		CAPACITOR, FIXED, MICA: CM04CD150J03, (81349)		EA	REF									3-32	A8A3A4A2C317 *
X1-D		CAPACITOR, FIXED, MICA: CM04ED200J03, (81349)		EA	6									3-32	A8A3A4A2C299 *
X1-D		CAPACITOR, FIXED, MICA: CM04ED200J03, (81349)		EA	REF									3-32	A8A3A4A2C301 *
X1-D		CAPACITOR, FIXED, MICA: CM04ED200J03, (81349)		EA	REF									3-32	A8A3A4A2C303 *
X1-D		CAPACITOR, FIXED, MICA: CM04ED200J03, (81349)		EA	REF									3-32	A8A3A4A2C314 *
X1-D		CAPACITOR, FIXED, MICA: CM04ED200J03, (81349)		EA	REF									3-32	A8A3A4A2C315 *
X1-D		CAPACITOR, FIXED, MICA: CM04ED200J03, (81349)		EA	REF									3-32	A8A3A4A2C317 *
X1-D		CAPACITOR, FIXED, MICA: CM04ED240J03, (81349)		EA	5									3-32	A8A3A4A2C299 *
X1-D		CAPACITOR, FIXED, MICA: CM04ED240J03, (81349)		EA	REF									3-32	A8A3A4A2C301 *
X1-D		CAPACITOR, FIXED, MICA: CM04ED240J03, (81349)		EA	REF									3-32	A8A3A4A2C303 *
X1-D		CAPACITOR, FIXED, MICA: CM04ED240J03, (81349)		EA	REF									3-32	A8A3A4A2C315 *
X1-D		CAPACITOR, FIXED, MICA: CM04ED240J03, (81349)		EA	REF									3-32	A8A3A4A2C317 *
X1-D		CAPACITOR, FIXED, MICA: CM04ED270G03, (81349)		EA	5									3-32	A8A3A4A2C299 *
X1-D		CAPACITOR, FIXED, MICA: CM04ED270G03, (81349)		EA	REF									3-32	A8A3A4A2C301 *
X1-D		CAPACITOR, FIXED, MICA: CM04ED270G03, (81349)		EA	REF									3-32	A8A3A4A2C303 *
X1-D		CAPACITOR, FIXED, MICA: CM04ED270G03; (81349)		EA	REF									3-32	A8A3A4A2C315 *
X1-D		CAPACITOR, FIXED, MICA: CM04ED270G03; (81349)		EA	REF									3-32	A8A3A4A2C317 *
X1-D		CAPACITOR, FIXED, MICA: CM04ED620F03, (81349)		EA	5									3-32	A8A3A4A2C299 *
X1-D		CAPACITOR, FIXED, MICA: CM04ED620F03, (81349)		EA	REF									3-32	A8A3A4A2C301 *
X1-D		CAPACITOR, FIXED, MICA: CM04ED620F03, (81349)		EA	REF									3-32	A8A3AE2C303 *
X1-D		CAPACITOR, FIXED, MICA: CM04ED620F03, (81349)		EA	REF									3-32	A8A3A4A2C315 *
X1-D		CAPACITOR, FIXED, MICA: CM04ED620F03, (813.9)		EA	REF									3-32	A8A3A4A2C317 *
X1-D		CAPACITOR, FIXED, MICA: CM04ED820F03, (81349)		EA	5									3-32	A8A3A4A2C299 *
X1-D		CAPACITOR, FIXED, MICA: CM04ED820F03, (81349)		EA	REF									3-32	A8A3A4A2C301 *

*SELECT PER OPERATIONAL REQUIREMENT.

REPAIR PARTS FOR DIRECT SUPPORT, GENERAL SUPPORT, AND DEPOT MAINTENANCE (Continued)															
(1) SMR CODE	(2) FEDERAL STOCK NUMBER	(3) DESCRIPTION Reference Number & Mfr. Code Usable on Code		(4) UNIT OF MEAS	(5) QTY INC IN UNIT	(6) 30 DAY DS MAINTENANCE ALLOWANCE			(7) 30 DAY GS MAINTENANCE ALLOWANCE			(8) 1 YR ALW PER 100 EQUIP CNTGCTY	(9) DEPOT MAINT ALW PER 100 EQUIP	(10) ILLUSTRATION	
						(a)	(b)	(c)	(a)	(b)	(c)			(a) FIG NO.	(b) ITEM NO. OR REFERENCE DESIGNATION
						1-20	21-50	51-100	1-20	21-50	51-100				
X1-D		CAPACITOR, FIXED, MICA: CM04EDB20F03, (81349)		EA	REF									3-32	A8A3A4A2C303 *
X1-D		CAPACITOR, FIXED, MICA: CM04ED820F03, (81349)		EA	REF									3-32	A8A3A4A2C315 *
X1-D		CAPACITOR, FIXED, MICA: CM04ED820F03; (81349)		EA	REF									3-32	A8A3A4A2C317 *
X1-D		CAPACITOR, FIXED, MICA: CM04FD910F03; (81349)		EA	5									3-32	A8A3A4A2C299 *
X1-D		CAPACITOR, FIXED, MICA: CM04FD910F03, (81349)		EA	REF									3-32	A8A3A4A2C301 *
X1-D		CAPACITOR, FIXED, MICA: CM04FD910F03, (81349)		EA	REF									3-32	A8A3ALA2C303 *
X1-D		CAPACITOR, FIXED, MICA: CM04FD910F03, (81349)		EA	REF									3-32	A8A3A4A2C315 *
X1-D		CAPACITOR, FIXED, MICA: CM04FD910F03, (81349)		EA	REF									3-32	A8A3A4A2C317 *
X1-D		CAPACITOR, FIXED, MICA: CM04FD101F03, (81349)		EA	5									3-32	A8A3A4A2C299 *
X1-D		CAPACITOR, FIXED, MICA: CM04FD101F03, (81349)		EA	REF									3-32	A8A3A4A2C301 *
X1-D		CAPACITOR, FIXED, MICA: CM04FD101F03, (81349)		EA	REF									3-32	A8A3A4A2C303 *
X1-D		CAPACITOR, FIXED, MICA: CM04FD101F03, (81349)		EA	REF									3-32	A8A3A4A2C315 *
X1-D		CAPACITOR, FIXED, MICA: CM04FD101F03, (81349)		EA	REF									3-32	A8A3A4A2C317 *
X1-D		CAPACITOR, FIXED, MICA: CM04FD111F03, (81349)		EA	5									3-32	A8A3A4A2C299 *
X1-D		CAPACITOR, FIXED, MICA: CM04FD111F03, (81349)		EA	REF									3-32	A8A3A4A2C301 *
X1-D		CAPACITOR, FIXED, MICA: CM04FD111F03, (81349)		EA	REF									3-32	A8A3A4A2C303 *
X1-D		CAPACITOR, FIXED, MICA: CM04FD111F03, (81349)		EA	REF									3-32	A8A3A4A2C315 *
X1-D		CAPACITOR, FIXED, MICA: CM04FD111F03, (81349)		EA	REF									3-32	A8A3A4A2C317 *
X1-D		CAPACITOR, FIXED, MICA: CM04FD121F03, (81349)		EA	1									3-32	A8A3A4A2C302
X1-D		CAPACITOR, FIXED, MICA: CM04FD131F03, (81349)		EA	5									3-32	A8A3A4A?C299 *
X1-D		CAPACITOR, FIXED, MICA: CM04FD131F03, (81349)		EA	REF									3-32	A8A3A4A2C301 *
X1-D		CAPACITOR, FIXED, MICA: CM04FD131F03, (81349)		EA	REF									3-32	A8A3A4A2C303 *
X1-D		CAPACITOR, FIXED, MICA: CM04FD131F03, (81349)		EA	REF									3-32	A8A3A4A2C315 *
X1-D		CAPACITOR, FIXED, MICA: CM04FD131F03, (81349)		EA	REF									3-32	A8A3A4A2C317 *
X1-D		CAPACITOR, FIXED, MICA: CM04FD151F03, (81349)		EA	6									3-32	A8A3A4A2C299 *

* SELECT PER OPERATIONAL REQUIREMENT.

SECTION II

TM 11-5820-509-35

REPAIR PARTS FOR DIRECT SUPPORT, GENERAL SUPPORT, AND DEPOT MAINTENANCE (Continued)															
(1) SMR CODE	(2) FEDERAL STOCK NUMBER	(3) DESCRIPTION Reference Number & Mfr. Code Usable on Code		(4) UNIT OF MEAS	(5) QTY INC IN UNIT	(6) 30 DAY DS MAINTENANCE ALLOWANCE			(7) 30 DAY GS MAINTENANCE ALLOWANCE			(8) 1 YR ALW PER 100 EQUIP CNTGCTY	(9) DEPOT MAINT ALW PER 100 EQUIP	(10) ILLUSTRATION	
						(a)	(b)	(c)	(a)	(b)	(c)			(a) FIG NO.	(b) ITEM NO. OR REFERENCE DESIGNATION
						1-20	21-50	51-100	1-20	21-50	51-100				
X1-D		CAPACITOR, FIXED, MICA: CM04FD151F03, (81349)		EA	REF									3-32	A8A3A4A2C300
X1-D		CAPACITOR, FIXED, MICA: CM04FD151F03, (81349)		EA	REF									3-32	A8A3A4A2C301 *
X1-D		CAPACITOR, FIXED, MICA: CM04FD151F03, (81349)		EA	REF									3-32	A8A3A4A2C303 *
X1-D		CAPACITOR, FIXED, MICA: CM04FD151F03, (81349)		EA	REF									3-32	A8A3A4A2C315 *
X1-D		CAPACITOR, FIXED, MICA: CM04FD151F03, (81349)		EA	REF									3-32	A8A3A4A2C317 *
X1-D		CAPACITOR, FIXED, MICA: CM04FA361F03, (81349)		EA	1									3-32	A8A3A4A2C298
X1-D		COIL, RADIO FREQUENCY-NO. 1: 548-7805-004, (13499)		EA	1									3-32	A8A3A4A2L144
X1-D		NUT, PLAIN, HEXAGON: 334-1290-000, (13499)		EA	1										A8A3ABA2L144H1
X1-D		WASHER, SPRING TENSION: 310-0397-00, (79807)		EA	1										A8A3A4A2L144H2
X1-D		COIL, RADIO FREQUENCY-NO. 2: 548-7806-000,(13499)		EA	1									3-32	A8A3A4A2L143
X1-D		NUT, PLAIN, HEXAGON: 334-1290-000, (13499)		EA	1										A8A3A4A2L143H1
X1-D		WASHER, SPRING TENSION: 310-0397-00, (79807)		EA	1										A8A3A4A2L143H2
X1-D		COIL, RADIO FREQUENCY-NO. 4: 548-7808-004, (13499)		EA	5									3-32	A8A3A4A2L128
X1-D		NUT, PLAIN, HEXAGON: 334-1290-000, (13499)		EA	1										A8A3A4A2L128H1
X1-D		WASHER, SPRING TENSION: 310-0397-00, (79807)		EA	1										A8A3A4A2L128H2
X1-D		COIL, RADIO FREQUENCY-NO. 4: 548-7808-004 (13499)		EA	REF									3-32	A8A3A4A2L129
X1-D		NUT, PLAIN, HEXAGON: 334-1290-000, (13499)		EA	1										A8A3A4A2L129H1
X1-D		WASHER, SPRING TENSION: 310-0397-00, (79807)		EA	1										A8A3A4A2L129H2
X1-D		COIL, RADIO FREQUENCY-NO. 4: 548-7808-004, (13499)		EA	REF									3-32	A8A3A4A2L130
X1-D		NUT, PLAIN, HEXAGON: 334-1290-000, (13499)		EA	1										A8A3A4A2L130H1
X1-D		WASHER, SPRING TENSION: 310-0397-00, (79807)		EA	1										A8A3A4A2L130H2
X1-D		COIL, RADIO FREQUENCY-NO. 4: 548-7808-004, (13499)		EA	REF									3-32	A8A3A4A2L131
X1-D		NUT, PLAIN, HEXAGON 334-1290-000, (13499)		EA	1										A8A3A4A2L131H1
X1-D		WASHER, SPRING TENSION: 310-0397-00, (79807)		EA	1										A8A3A4A2L131H2
X1-D		COIL, RADIO FEQUENCY-NO. 4 548-7808-004, (13499)		EA	REF									3-32	A8A3A4A2L132

* SELECT PER OPERATIONAL REQUIREMENT.

REPAIR PARTS FOR DIRECT SUPPORT, GENERAL SUPPORT, AND DEPOT MAINTENANCE (Continued)															
(1) SMR CODE	(2) FEDERAL STOCK NUMBER	(3) DESCRIPTION Reference Number & Mfr. Code Usable on Code		(4) UNIT OF MEAS	(5) QTY INC IN UNIT	(6) 30 DAY DS MAINTENANCE ALLOWANCE			(7) 30 DAY GS MAINTENANCE ALLOWANCE			(8) 1 YR ALW PER 100 EQUIP CNTGCTY	(9) DEPOT MAINT ALW PER 100 EQUIP	(10) ILLUSTRATION	
						(a)	(b)	(c)	(a)	(b)	(c)			(a) FIG NO.	(b) ITEM NO. OR REFERENCE DESIGNATION
						1-20	21-50	51-100	1-20	21-50	51-100				
X1-D		NUT, PLAIN, HEXAGON: 334-1290-000, (13499)		EA	1										A8A3A4A2L132H1
X1-D		WASHER, SPRING TENSION: 310-0397-00; (79807)		EA	1										A8A3A4A2L132H2
X1-D		COIL, RADIO FREQUENCY-NO. 9: 548-7813-004, (13499)		EA	1								3-32		A8A3A4A2L137
X1-D		NUT, PLAIN, HEXAGON: 334-1290-000, (13499)		EA	1										A8A384A2L137H1
X1-D		WASHER, SPRING TENSION: 310-0397-00, (79807)		EA	1										A8A3A4A2L137H2
X1-D		COIL, RADIO FREQUENCY-NO. 10: 548-7814-004, (13499)		EA	1								3-32		A8A3A4A2L136
X1-D		NUT, PLAIN, HEXAGON: 334-1290-000, (13499)		EA	1										A8A3A4A2L136H1
X1-D		WASHER, SPRING TENSION: 310-0397-00, (79807)		EA	1										A8A3A4A2L136H2
X1-D		COIL, RADIO FREQUENCY-NO. 11: 548-7815-004, (13499)		EA	1								3-32		A8A3A4A2L135
X1-D		NUT, PLAIN, HEXAGON 334-1290-000; (13499)		EA	1										A8A3A4A2L135H1
X1-D		WASHER, SPRING TENSION: 310-0397-00, (79807)		EA	1										A8A3A2L135H2
X1-D		RESISTOR, FIXED, COMPOSITION: RCR05GF682K; (81349)		EA	2								3-32		A8A3A4A2R173
X1-D		RESISTOR, FIXED, COMPOSITION: RCR05GF682K, (81349)		EA	REF								3-32		A8A3A4A2R179
X1-D		RESISTOR, FIXED, COMPOSITION: RC05GF822K, (81349)		EA	1								3-32		A8A3A4A2R172
X1-D		TERMINAL, LUG: 4007-8HT; (77147)		EA	3										A8A3A4A2E1
X1-D		TERMINAL, LUG: 4007-8HT, (77147)		EA	REF										A8A3A4A2E2
X1-D		TERMINAL, LUG: 4007-8HT, (77147)		EA	REF										A8A3A4A2E3
X1-D		TERMINAL, LUG: 548-7800-002; (13499)		EA	5										A8A3A4A2E4
X1-D		TERMINAL, LUG 548-7800-002, (13499)		EA	REF										A8A3A4A2E5
X1-D		TERMINAL, LUG: 548-7800-002, (13499)		EA	REF										A8A3A4A2E6
X1-D		TERMINAL, LUG: 548-7800-002, (13499)		EA	REF										A8A3A4A2E7
X1-D		TERMINAL, LUG: 548-7800-002, (13499)		EA	REF										A8A3A4A2E8
X1-D		TERMINAL, STUD: AB397-1A, (12615)		EA	4										A8A3A4A2E9
X1-D		WASHER, SPRING TENSION. 310-0075-00, (79807)		EA	1										A8A3A4A2E9H1
X1-D		TERMINAL, STUD AB397-1A, (12615)		EA	REF										A8A3A4A2E10

REPAIR PARTS FOR DIRECT SUPPORT, GENERAL SUPPORT, AND DEPOT MAINTENANCE (Continued)															
(1) SMR CODE	(2) FEDERAL STOCK NUMBER	(3) DESCRIPTION Reference Number & Mfr. Code Usable on Code		(4) UNIT OF MEAS	(5) QTY INC IN UNIT	(6) 30 DAY DS MAINTENANCE ALLOWANCE			(7) 30 DAY GS MAINTENANCE ALLOWANCE			(8) 1 YR ALW PER 100 EQUIP CNTGCTY	(9) DEPOT MAINT ALW PER 100 EQUIP	(10) ILLUSTRATION	
						(a)	(b)	(c)	(a)	(b)	(c)			(a)	(b)
						1-20	21-50	51-100	1-20	21-50	51-100			FIG NO.	ITEM NO. OR REFERENCE DESIGNATION
X1-D		WASHER, SPRING TENSION: 310-0075-00, (79807)		EA	1										A8A3A4A2E10H1
X1-D		TERMINAL, STUD: AB397-1A, (12615)		EA	REF										A8A3A4A2E11
X1-D		WASHER, SPRING TENSION: 310-0075-00, (79807)		EA	1										A8A3A4A2E11H1
X1-D		TERMINAL, STUD: AB397-1A, (12615)		EA	REF										A8A3A4A2E12
X1-D		WASHER, SPRING TENSION: 310-0075-00, (79807)		EA	1										A8A3A4A2E12H1
P-D	5325-174-5317	GROMMET, RUBBER: MS35489-4, (96906)		EA	2							REF	REF		A8A3A4H1
P-D	5325-174-5317	GROMMET, RUBBER: MS35489-4, (96906)		EA	REF							REF	REF		A8A3A4H2
P-D		GUIDE, SWITCH-NO. 1: 58-7870-004, (13499)		EA	1							*	*		A8A3A4MP1
P-D	5305-777-6039	SCREW, MACHINE: MS51959-12, (96906)		EA	3							*	*		A8A3A4MP1H1
P-D	5305-777-6039	SCREW, MACHINE: MS51959-12, (96906)		EA	REF							REF	REF		A8A3A4MP1H2
P-D	5305-777-6039	SCREW, MACHINE: MS51959-12, (96906)		EA	REF							REF	REF		A8A3A4MP1H3
P-D		GUIDE, SWITCH-NO. 2: 548-7872-004, (13499)		EA	1							*	*		A8A3A4MP2
P-D	5305-777-6039	SCREW, MACHINE: MS51959-12, (96906)		EA	3							REF	REF		A8A3A4MP2H1
P-D	5305-777-6039	SCREW, MACHINE: MS51959-12, (96960)		EA	REF							REF	REF		A8A3A4MP2H2
P-D	5305-777-6039	SCREW, MACHINE: MS51959-12, (96 906)		EA	REF							REF	REF		A8A3A4MP2H3
P-D	5305-151-2336	SCREW, MACHINE: P342-0162-000, (77250)		EA	2							*	*		A8A3A4MP2H4
P-D	5305-151-2336	SCREW, MACHINE: P342-0162-000, (77250)		EA	REF							REF	REF		A8A3A4MP2H5
P-D		NUT, SLEEVE: 548-7782-002, (13499)		EA	2							*	*		A8A3A4MP3
P-D		NUT, SLEEVE: 548-7782-002, (13499)		EA	REF							REF	REF		A8A3A4P4
P-D		RESISTOR, FIXED, COMPOSITION: RCR07G102KS, (81349)		EA	1							REF	REF	3-33	A7A3A4R161
P-D		RESISTOR, FIXED, COMPOSITION RCR07G182KS, (81349)		EA	1							*	*	3-33	A8A3A4R171
P-D		RESISTOR, FIXED, COMPOSITION RCR07G272KS, (81349)		EA	2							REF	REF	3-34	A8A3A4R168
P-D		RESISTOR, FIXED, COMPOSITION RCR07G272KS, (81349)		EA	REF							REF	REF	3-34	A8A3A4R170
P-D	5905-752-3340	RESISTOR, FIXED, COMPOSITION RCR07G472KS, (81349)		EA	1							REF	REF	3-33	A8A3A4R159
P-D		RESISTOR, FIXED, COMPOSITION RCR07G562KS, (81349)		EA	1							REF	REF	3-33	A8A3A4R160

REPAIR PARTS FOR DIRECT SUPPORT, GENERAL SUPPORT, AND DEPOT MAINTENANCE (Continued)															
(1) SMR CODE	(2) FEDERAL STOCK NUMBER	(3) DESCRIPTION Reference Number & Mfr. Code Usable on Code		(4) UNIT OF MEAS	(5) QTY INC IN UNIT	(6) 30 DAY DS MAINTENANCE ALLOWANCE			(7) 30 DAY GS MAINTENANCE ALLOWANCE			(8) 1 YR ALW PER 100 EQUIP CNTGCTY	(9) DEPOT MAINT ALW PER 100 EQUIP	(10) ILLUSTRATION	
						(a)	(b)	(c)	(a)	(b)	(c)			(a)	(b)
						1-20	21-50	51-100	1-20	21-50	51-100			FIG NO.	ITEM NO. OR REFERENCE DESIGNATION
P-D		RESISTOR, FIXED, COMPOSITION: RCR07G104KS; (81349)	EA	4							*	*	3-34	A8A3A4R165	
P-D		RESISTOR, FIXED, COMPOSITION: RCR07G104KS; (81349)	EA	REF							REF	REF	3-34	A8A3A4R166	
P-D		RESISTOR, FIXED, COMPOSITION RCR07G104KS; (81349)	EA	REF							REF	REF	3-34	A8A3A4R167	
P-D		RESISTOR, FIXED, COMPOSITION. RCR07G104KS, (81349)	EA	REF							REF	REF	3-34	A8A3A4R169	
P-D	5905-068-1538	RESISTOR, FIXED, FILM: RW60D2611F; (81349)	EA	1							*	*	3-33	A8A3A4R157	
P-D	5905-985-5435	RESISTOR, FIXED, FILM: RW60D7501F; (81349)	EA	1							*	*	3-34	A8A3A4R164	
P-D	5905-892-6578	RESISTOR, FIXED: RN60D1212F; (81349)	EA	1							*	*	3-34	A8A3A4R163	
P-D	5905-761-1905	RESISTOR, FIXED, FILM: RW60D1332F; (81349)	EA	2							*	*	3-33	A8A3A4R158	
P-D	5905-761-1905	RESISTOR, FIXED, FILM: RW60D1332F; (81349)	EA	REF							REF	REF	3-33	A8A3A4R180	
P-D	5905-990-2246	RESISTOR, FIXED, FILM: RN60D1101F; (81349)	EA	1							*	*	3-33	A8A3A4R156	
M-D		SPACER, SLEEVE: 548-7786-003, (13499)	EA	2										A8A3A4MP5	
M-D		SPACER, SLEEVE: 548-7786-003; (13499)	EA	REF										A8A3A4MP6	
M-D		SPACER, SLEEVE: 548-7787-003; (13499)	EA	2										A8A3A4MP7	
M-D		SPACER, SLEEVE: 548-7787-003, (13499)	EA	REF										A8A3A4MP8	
M-D		SPACER, SLEEVE: 548-7788-03, (13499)	EA	2										A8A3A4MP9	
M-D		SPACER, SLEEVE: 548-7788-003, (13499)	EA	REF										A8A3A4MP10	
P-D	5930-960-7842	SWITCH, SECTION ROTARY: 232084FC; (76854)	EA	1							*	*	3-34	A8A3A4S7	
P-D	5930-078-1717	SWITCH, SECTION ROTARY: 232085FC; (76854)	EA	1							*	*	3-33	A8A3A4S10	
P-D	5930-960-7841	SWITCH, SECTION ROTARY: 232668FC; (76854)	EA	1							*	*	3-33	A8A3AS6	
P-D		TERMINAL, LUG: 4040-2HT, (77147)	EA	4							REF	REF		A8A3AE1	
P-D	5305-576-6002	SCREW, MACHINE: P343-0298-000; (77250)	EA	1							REF	REF		A8A3A4E1H1	
P-D	5310-680-5557	WASHER, SPRING TENSION: 310-0075-000; (79807)	EA	1							REF	REF		A8A3A4E1H2	
P-D		TERMINAL, LUG: 4040-2HT, (77147)	EA	REF							REF	RED		A8A3A4E2	
P-D	5305-576-6002	SCREW, MACHINE: P343-0298-000, (77250)	EA	1							REF	REF		A8A3A4E2H1	
P-D	5310-680-5557	WASHER, SPRING TENSION: 310-0075-000; (79807)	EA	1							REF	REF		A8A3A4E2H2	

SECTION II

TM 11-5820-509-35

REPAIR PARTS FOR DIRECT SUPPORT, GENERAL SUPPORT, AND DEPOT MAINTENANCE (Continued)															
(1) SMR CODE	(2) FEDERAL STOCK NUMBER	(3) DESCRIPTION Reference Number & Mfr. Code Usable on Code		(4) UNIT OF MEAS	(5) QTY INC IN UNIT	(6) 30 DAY DS MAINTENANCE ALLOWANCE			(7) 30 DAY GS MAINTENANCE ALLOWANCE			(8) 1 YR ALW PER 100 EQUIP CNTGCTY	(9) DEPOT MAINT ALW PER 100 EQUIP	(10) ILLUSTRATION	
						(a)	(b)	(c)	(a)	(b)	(c)			(a) FIG NO.	(b) ITEM NO. OR REFERENCE DESIGNATION
						1-20	21-50	51-100	1-20	21-50	51-100				
P-D		TERMINAL, LUG: 4040-2HT, (77147)		EA	REF							REF	REF		A8A3A4E3
P-D	5310-208-7021	NUT, PLAIN, HEXAGON: P313-0156-000, (77250)		EA	1							*	*		A8A3A4E3H1
P-D	5305-576-6002	SCREW, MACHINE: P343-0298-000, (77250)		EA	1							REF	REF		A8A3A4E3H2
P-D	5310-680-5557	WASHER, SPRING TENSION: 310-0075-000, (79807)		EA	1							REF	REF		A8A3A4E3H3
P-D		TERMINAL, LUG: 4040-2HT, (77147)		EA	REF							REF	REF		A8A3A4E4
P-D	5310-208-702 1	NUT, PLAIN, HEXAGON: P313-0156-000, (77250)		EA	1							REF	REF		A8A3A4E4H1
P-D	5305-576-6002	SCREW, MACHINE P341-0298-000, (77250)		EA	1							REF	REF		A8A3A4E4H2
P-D	5305-680-5557	WASHER, SPRING TENSION: 310-0075-000, (79807)		EA	1							REF	REF		A8A3A4E4H3
P-D	5961-953-4485	TRANSISTOR: 2N917, (07688)		EA	2							*	*	3-33	A8A3A4Q20
P-D	5961-953-4485	TRANSISTOR: 2N917, (07688)		EA	REF							REF	REF	3-33	A8A3A4Q21
M-D		PAD, RUBBER: 548-7761-002, (13499)		EA	4										A8A3MP18
M-D		PAD, RUBBER: 548-7761-002, (13499)		EA	REF										A8A3MP19
M-D		PAD, RUBBER: 548-7761-002, (13499)		EA	REF										A8A3MP20
M-D		PAD, RUBBER: 548-7761-002; (13499)		EA	REF										A8A3MP21
P-D	5315-847-3735	PIN, SPRING, SELF-LOCKING: MS16562-190, (96906)		EA	2							*	*		A8A3MP22
P-D	5315-847-3735	PIN, SPRING, SELF-LOCKING: MS16562-190, (96906)		EA	REF							REF	REF		A8A3MP23
M-D		PLATE ASSEMBLY, TOP: 548-7912-00, (13499)		EA	1										A8A3MP24
P-D	5305-777-6039	SCREW, MACHINE: MS51959-12, (96906)		EA	4							REF	REF		A8A3MP24H1
P-D	5305-777-6039	SCREW, MACHINE: MS51959-12, (96906)		EA	REF							REF	REF		A8A3MP24H2
P-D	5305-777-6039	SCREW, MACHINE MS51959-12, (96906)		EA	REF							REF	REF		A8A3MP243
P-D	5305-777-6039	SCREW, MACHINE MS51959-12, (96906)		EA	REF							REF	REF		A8A3MP24H4
P-D	5305-054-5647	SCREW, MACHINE MS51957-13, (96906)		EA	16							REF	REF		A8A3MP24H5
P-D	5305-054-5647	SCREW, MACHINE: MS51957-13, (96906)		EA	REF							REF	REF		A8A3MP24H6
P-D	5305-054-5647	SCREW, MACHINE: MS51957-13, (96906)		EA	REF							REF	REF		A8A3MP24H7
P-D	5305-054-5647	SCREW, MACHINE: MS51957-13, (96906)		EA	REF							REF	REF		A8A3MP24H8

REPAIR PARTS FOR DIRECT SUPPORT, GENERAL SUPPORT, AND DEPOT MAINTENANCE (Continued)															
(1) SMR CODE	(2) FEDERAL STOCK NUMBER	(3) DESCRIPTION Reference Number & Mfr. Code Usable on Code		(4) UNIT OF MEAS	(5) QTY INC IN UNIT	(6) 30 DAY DS MAINTENANCE ALLOWANCE			(7) 30 DAY GS MAINTENANCE ALLOWANCE			(8) 1 YR ALW PER 100 EQUIP CNTGCTY	(9) DEPOT MAINT ALW PER 100 EQUIP	(10) ILLUSTRATION	
						(a)	(b)	(c)	(a)	(b)	(c)			(a) FIG NO.	(b) ITEM NO. OR REFERENCE DESIGNATION
						1-20	21-50	51-100	1-20	21-50	51-100				
P-D	5305-054-5647	SCREW, MACHINE: MS51957-13, (96906)		EA	REF							REF	REF	A8A3MP24H9	
P-D	5305-054-5647	SCREW, MACHINE: MS51957-13, (96906)		EA	REF							REF	REF	A8A3MP24H10	
P-D	5305-054-5647	SCREW, MACHINE: MS51957-13; (96906)		EA	REF							REF	REF	A8A3MP24H11	
P-D	5305-054-5647	SCREW, MACHINE: MS51957-13, (96906)		EA	REF							REF	REF	A8A3MP24H12	
P-D	5305-054-5647	SCREW, MACHINE: MS51957-13, (96906)		EA	REF							REF	REF	A8A3MP24H13	
P-D	5305-054-5647	SCREW, MACHINE: MS51957-13, (96906)		EA	REF							REF	REF	A8A3MP24H14	
P-D	5305-054-5647	SCREW, MACHINE: MS51957-13, (96906)		EA	REF							REF	REF	A8A3MP24H15	
P-D	5305-054-5647	SCREW, MACHINE: MS51957-13, (96906)		EA	REF							REF	REF	A8A3MP24H16	
P-D	5305-054-5647	SCREW, MACHINE: MS51957-13, (96906)		EA	REF							REF	REF	A8A3MP24H17	
P-D	5305-054-5647	SCREW, MACHINE: MS51957-13, (96906)		EA	REF							REF	REF	A8A3MP24H18	
P-D	5305-054-5647	SCREW, MACHINE: MS51957-13; (96906)		EA	REF							REF	REF	A8A3MP24H19	
P-D	5305-054-5647	SCREW, MACHINE: MS51957-13; (96906)		EA	REF							REF	REF	A8A3MP24H20	
P-D		WASHER, LOCK: MS35338-13, (96906)		EA	16							REF	REF	A8A3MP24H21	
P-D		WASHER, LOCK: MS35338-135, (96906)		EA	REF							REF	REF	A8A3MP24H22	
P-D		WASHER, LOCK: MS35338-135, (96906)		EA	REF							REF	REF	A8A3MP24H23	
P-D		WASHER, LOCK: MS35338-135, (96906)		EA	REF							REF	REF	A8A3MP24H24	
P-D		WASHER, LOCK: MS35338-135; (96906)		EA	REF							REF	REF	A8A3MP24H25	
P-D		WASHER, LOCK: MS35338-135, (96906)		EA	REF							REF	REF	A8A3MP24H26	
P-D		WASHER, LOCK: MS35338-135, (96906)		EA	REF							REF	REF	A8A3MP24H27	
P-D		WASHER, LOCK: MS35338-135; (96906)		EA	REF							REF	REF	A8A3MP24H28	
P-D		WASHER, LOCK: MS35338-135, (96906)		EA	REF							REF	REF	A8A3MP24H29	
P-D		WASHER, LOCK: MS35338-135, (96906)		EA	REF							REF	REF	A8A3MP24H30	
P-D		WASHER, LOCK: MS35338-135; (96906)		EA	REF							REF	REF	A8A3MP24H31	
P-D		WASHER, LOCK: MS35338-135, (96906)		EA	REF							REF	REF	A8A3MP24H32	
P-D		WASHER, LOCK: MS35338-135, (96906)		EA	REF							REF	REF	A8A3MP24H33	

REPAIR PARTS FOR DIRECT SUPPORT, GENERAL SUPPORT, AND DEPOT MAINTENANCE (Continued)															
(1) SMR CODE	(2) FEDERAL STOCK NUMBER	(3) DESCRIPTION Reference Number & Mfr. Code Usable on Code		(4) UNIT OF MEAS	(5) QTY INC IN UNIT	(6) 30 DAY DS MAINTENANCE ALLOWANCE			(7) 30 DAY GS MAINTENANCE ALLOWANCE			(8) 1 YR ALW PER 100 EQUIP CNTGCTY	(9) DEPOT MAINT ALW PER 100 EQUIP	(10) ILLUSTRATION	
						(a)	(b)	(c)	(a)	(b)	(c)			(a) FIG NO.	(b) ITEM NO. OR REFERENCE DESIGNATION
						1-20	21-50	51-100	1-20	21-50	51-100				
P-D		WASHER, LOCK: MS35338-135, (96906)		EA	REF							REF	REF		A8A3MP24M34
P-D		WASHER, LOCK: MS35338-135, (96906)		EA	REF							REF	REF		A8A3MP24H35
P-D		WASHER, LOCK: MS35338-135, (96906)		EA	REF							REF	REF		A8A3MP24H36
M-D		PLATE, CONNECTOR: 548-7882-004, (13499)		EA	1										A8A3MP25
P-D		SCREW, SELF-LOCKING: LP51959-13M, (03038)		EA	23							REF	REF		A8A3MP25H1
P-D		SCREW, SELF-LOCKING: LP51959-13M, (03038)		EA	REF							REF	REF		A8A3MP25H2
P-D		SCREW, SELF-LOCKING: LP51959-13M, (03038)		EA	REF							REF	REF		A8A3MP25H3
P-D		SCREW, SELF-LOCKING: LP51959-13M, (03038)		EA	REF							REF	REF		A8A3MP25H4
P-D		SCREW, SELF-LOCKING: LP51959-13M, (03038)		EA	REF							REF	REF		A8A3MP25H5
P-D		SCREW, SELF-LOCKING: LP51959-13M, (03038)		EA	REF							REF	REF		A8A3MP25H6
P-D		SCREW, SELF-LOCKING: LP51959-13M, (03038)		EA	REF							REF	REF		A8A3MP25H7
P-D		SCREW, SELF-LOCKING: LP51959-13M, (03038)		EA	REF							REF	REF		A8A3MP25H8
P-D		SCREW, SELF-LOCKING: LP51959-13M, (03038)		EA	REF							REF	REF		A8A3MP25H9
P-D		SCREW, SELF-LOCKING: LP51959-13M, (03038)		EA	REF							REF	REF		A8A3MP25H10
P-D		SCREW, SELF-LOCKING: LP51959-13M, (03038)		EA	REF							REF	REF		A8A3MP25H11
P-D		SCREW, SELF-LOCKING: LP51959-13M, (03038)		EA	REF							REF	REF		A8A3MP25H12
P-D		SCREW, SELF-LOCKING: LP51959-13M, (03038)		EA	REF							REF	REF		A8A3MP25H13
P-D		SCREW, SELF-LOCKING: LP51959-13M, (03038)		EA	REF							REF	REF		A8A3MP25H15
P-D		SCREW, SELF-LOCKING: LP51959-13M, (03038)		EA	REF							REF	REF		A8A3MP25H16
P-D		SCREW, SELF-LOCKING: LP51959-13M, (03038)		EA	REF							REF	REF		A8A3MP25H17
P-D		SCREW, SELF-LOCKING: LP51959-13M, (03038)		EA	REF							REF	REF		A8A3MP25H18
P-D		SCREW, SELF-LOCKING: LP51959-13M, (03038)		EA	REF							REF	REF		A8A3MP25H19
P-D		SCREW, SELF-LOCKING: LP51959-13M, (03038)		EA	REF							REF	REF		A8A3MP25H20
P-D		SCREW, SELF-LOCKING: LP51959-13M, (03038)		EA	REF							REF	REF		A8A3MP25H21

REPAIR PARTS FOR DIRECT SUPPORT, GENERAL SUPPORT, AND DEPOT MAINTENANCE (Continued)															
(1) SMR CODE	(2) FEDERAL STOCK NUMBER	(3) DESCRIPTION Reference Number & Mfr. Code Usable on Code		(4) UNIT OF MEAS	(5) QTY INC IN UNIT	(6) 30 DAY DS MAINTENANCE ALLOWANCE			(7) 30 DAY GS MAINTENANCE ALLOWANCE			(8) 1 YR ALW PER 100 EQUIP CNTGCT	(9) DEPOT MAINT ALW PER 100 EQUIP	(10) ILLUSTRATION	
						(a)	(b)	(c)	(a)	(b)	(c)			(a)	(b)
						1-20	21-50	51-100	1-20	21-50	51-100			FIG NO.	ITEM NO. OR REFERENCE DESIGNATION
P-D		SCREW, SELF-LOCKING: LP51959-13M; (03038)		EA	REF							REF	REF		A8A3MP25H22
P-D		SCREW, SELF-LOCKING: LP51959-13M, (03038)		EA	REF							REF	REF		A8A3MP25H23
M-D		PLATE, ELECTRICAL SHIELD: 549-6601-003, (13h99)		EA	1										A8A3MP26
M-D		PLATE, FRONT PRESSED: 549-5921-003, (13499)		EA	1										A8A3A5
P-D		SCREW, SELF-LOCKING: LP51959-13M, (03038)		EA	6							REF	REF		A8A3A5H6
M-D	5340-479-9197	INSERT, SCREW THREAD: MS122119, (96906)		EA	2										A8A3A5MP1
M-D	5340-479-9197	INSERT, SCREW THREAD: MS122119; (96906)		EA	REF										A8A3A5MP2
M-D		PIN, LOCATING: 549-5878-002; (13499)		EA	1										A8A3A5MP3
M-D		PLATE, FRONT: 549-5952-004; (13499)		EA	1										A8A3A5MP4
M-D		SHAFT, STRAIGHT-ARM: 549-5866-002, (13499)		EA	1										A8A3A5MP5
M-D		PLATE, MOUNTING, COIL: 548-7779-003, (13499)		EA	1										A8A3MP26
P-D	5305-764-2966	SCREW, MACHINE: MS51959-2, (96906)		EA	3							*	*		A8A3MP26H1
P-D	5305-764-2966	SCREW, MACHINE: MS51959-2, (96906)		EA	REF							REF	REF		A8A3MP26H2
P-D	5305-764-2966	SCREW, MACHINE: MS51959-2, (96906)		EA	REF							REF	REF		A8A3MP26H3
M-D		PLATE, REAR-PRESSED: 549-5922-003, (13499)		EA	1										A8A3A6
P-D		SCREW, SELF-LOCKING: LP51959-13M, (03038)		EA	6							REF	REF		A8A3A6H6
M-D	5340-479-9197	INSERT, SCREW THREAD MS122119, (96906)		EA	2										A8A3A6MP1
M-D	5340-479-9197	INSERT, SCREW THREAD: MS122119, (96906)		EA	REF										A8A3A6MP2
M-D		PIN, LOCATING: 549-5878-002, (13499)		EA	1										A8A3A6MP3
P-D	5315-614-3586	PIN, SPRING, TUBULAR, SLOTTED: MS16562-212, (96906)		EA	2							*	*		A8A3A6MP4
P-D	5315-614-3586	PIN, SPRING, TUBULAR, SLOTTED: MS16562-212, (96906)		EA	REF							REF	REF		A8A3A6MP5
M-D		PLATE, REAR: 549-5953-004, (13499)		EA	1										A8A3A6MP6
M-D	5325-975-7643	SHAFT, STRAIGHT-ARM: 549-5866-002, (13499)		EA	1										A8A3A6MP7
P-D	3020-985-3351	PULLEY; FLAT-IDLER: 549-5859-002, (13499)		EA	2							*	*		A8A3MP27
P-D	3020-985-3351	PULLEY, FLAT-IDLER: 549-5859-002, (13499)		EA	REF							REF	REF		A8A3MP28

REPAIR PARTS FOR DIRECT SUPPORT, GENERAL SUPPORT, AND DEPOT MAINTENANCE (Continued)															
(1) SMR CODE	(2) FEDERAL STOCK NUMBER	(3) DESCRIPTION Reference Number & Mfr. Code Usable on Code		(4) UNIT OF MEAS	(5) QTY INC IN UNIT	(6) 30 DAY DS MAINTENANCE ALLOWANCE			(7) 30 DAY GS MAINTENANCE ALLOWANCE			(8) 1 YR ALW PER 100 EQUIP CNTGCTY	(9) DEPOT MAINT ALW PER 100 EQUIP	(10) ILLUSTRATION	
						(a)	(b)	(c)	(a)	(b)	(c)			(a) FIG NO.	(b) ITEM NO. OR REFERENCE DESIGNATION
						1-20	21-50	51-100	1-20	21-50	51-100				
M-D	5820-975-7641	RAIL, RACK-LEFT: 549-5865-002, (13499)		EA	1										A8A3MP29
M-D	5820-975-7640	RAIL, RACK-RIGHT: 549-5864-002, (13499)		EA	1										A8A3MP30
P-D	5960-617-5785	RETAINER, ELECTRON TUBE: 541-6522-002, (13499)		EA	1										A8A3MP31
P-D	5905-825-2360	RESISTOR, FIXED, COMPOSITION: RCR07G221KS, (81349)		EA	1							REF	REF	3-41	A8A3R181
P-D		RESISTOR, FIXED, COMPOSITION: RCR07G102KS, (81349)		EA	1							REF	REF	3-41	A8A3R88
P-D	5905-752-3157	RESISTOR, FIXED, COMPOSITION: RCR07G273KS, (81349)		EA	1							REF	REF	3-40	A8A3R18
P-D	5905-686-4530	RESISTOR, FIXED, COMPOSITION: RCR07G104KS, (81349)		EA	1							REF	REF	3-40	A8A3R19
P-D	5905-816-8554	RESISTOR, FIXED, COMPOSITION: RCR07G103KS, (81349)		EA	1							REF	REF	3-40	A8A3R17
P-D	5905-033-9852	RESISTOR, FIXED, COMPOSITION: RCR32G101KS, (81349)		EA	1							*	*	3-40	A8A3R20
P-D		RESISTOR, FIXED, COMPOSITION: RC42GF123K, (81349)		EA	2							*	*	3-41	A8A3R82
P-D		RESISTOR, FIXED, COMPOSITION: RC42GF123K, (81349)		EA	REF							REF	REF	3-41	A8A3R182
P-D	5340-282-1633	RING, RETAINING: MS16633-1018, (96906)		EA	4							*	*		A8A3H9
P-D	5340-282-1633	RING, RETAINING: MS16633-1018, (96906)		EA	REF							REF	REF		A8A3H10
P-D	5340-282-1633	RING, RETAINING: MS16633-1018, (96906)		EA	REF							REF	REF		A8A3H11
P-D	5340-282-1633	RING, RETAINING: MS16633-1018, (96906)		EA	REF							REF	REF		A8A3H12
P-D	5340-598-1267	RING, RETAINING: 5133-15C, (79136)		EA	6							*	*		A8A3H13
P-D	5340-598-1267	RING, RETAINING: 5133-15C, (79136)		EA	REF							REF	REF		A8A3H14
P-D	5340-598-1267	RING, RETAINING: 5133-15C, (79136)		EA	REF							REF	REF		A8A3H15
P-D	5340-598-1267	RING, RETAINING: 8433-15C, (79136)		EA	REF							REF	REF		A8A3H16
P-D	5340-598-1267	RING, RETAINING: 5133-15C, (79136)		EA	REF							REF	REF		A8A3H17
P-D	5340-598-1267	RING, RETAINING: 5133-15C, (79136)		EA	REF							REF	REF		A8A3H18
P-D	5365-200-8530	RING, RETAINING: 5133-15C, (79136)		EA	5							*	*		A8A3H19
P-D		RING, RETAINING: 5101-37MD, (89462)		EA	REF							REF	REF		A8A3H20
P-D		RING, RETAINING: 5101-37MD, (89462)		EA	REF							REF	REF		A8A3H21
P-D		RING, RETAINING: 5101-37MD, (89L62)		EA	REF							REF	REF		A8A3H22

REPAIR PARTS FOR DIRECT SUPPORT, GENERAL SUPPORT, AND DEPOT MAINTENANCE (Continued)															
(1) SMR CODE	(2) FEDERAL STOCK NUMBER	(3) DESCRIPTION Reference Number & Mfr. Code Usable on Code		(4) UNIT OF MEAS	(5) QTY INC IN UNIT	(6) 30 DAY DS MAINTENANCE ALLOWANCE			(7) 30 DAY GS MAINTENANCE ALLOWANCE			(8) 1 YR ALW PER 100 EQUIP CNTGCTY	(9) DEPOT MAINT ALW PER 100 EQUIP	(10) ILLUSTRATION	
						(a)	(b)	(c)	(a)	(b)	(c)			(a) FIG NO.	(b) ITEM NO. OR REFERENCE DESIGNATION
						1-20	21-50	51-100	1-20	21-50	51-100				
P-D		RING, RETAINING: 5101-37MD, (89462)		EA	REF							REF	REF		A8A3H23
P-D		SEMICONDUCTOR DEVICE, DIODE: 1N3036A, (07688)		EA	1							*	*	3-41	A8A3CR7
M-D	5820-975-7642	SHAFT ASSEMBLY, DRIVE: 549-5870-002, (13499)		EA	1										A8A3A7
P-D	5315-531-9482	PIN, SPRING, TUBULAR, SLOTTED: MS16562-197, (96906)		EA	2							*	*		A8A3A7MP1
P-D	5315-531-9482	PIN, SPRING, TUBULAR, SLOTTED: MS16562-197, (96906)		EA	REF							REF	REF		A8A3A7MP2
P-D	3020-432-1739	PULLEY, FLAT, DRIVE: 549-5861-002, (13499)		EA	2							*	*		A8A3A7MP3
P-D		PULLEY, FLAT, DRIVE: 549-5861-002, (13499)		EA	REF							REF	REF		A8A3A7MP4
M-D		SHAFT, STRAIGHT-LOWER: 549-5857-002, (13499)		EA	1										A8A3A7MP5
M-D	5315-987-8790	SHAFT, STRAIGHT-UPPER: 549-5858-002, (13499)		EA	1										A8A3A7MP6
M-D	5820-975-7638	SHAFT ASSEMBLY, SWITCH: 549-5887-002, (13499)		EA	1										A8A3A8
M-D		COUPLING, HALF ASSEMBLY-SWITCH 549-5882-002, (13499)		EA	1										A8A3A8A1
M-D		COUPLING, HALF SHAFT-NO. 2: 549-5854-002, (13499)		EA	1										A8A3A8A1MP1
M-D		INSERT, FLEXIBLE COUPLING: 549-5720-002, (13499)		EA	1										A8A3A8A1MP2
M-D		PIN, SHOULDER HEADED: 549-5721-002, (13499)		EA	1										A8A3A8A1MP3
P-D	5315-853-0681	PIN, SPRING, TUBULAR SLOTTED: MS16562-201, (96906)		EA	1							*	*		A8A3A8MP1
M-D		SHAFT, STRAIGHT: 549-5846-002, (13499)		EA	1										A8A3A8MP2
M-D		SHIELD, COIL, RIVETED: 756-3173-002, (13499)		EA	1										A8A3E10
P-D	5305-054-5647	SCREW, MACHINE: MS51957-13, (96906)		EA	2							REF	REF		A8A3E10H1
P-D	5305-054-5647	SCREW, MACHINE: MS51957-13, (96906)		EA	REF							REF	REF		A8A3E10H2
P-D		WASHER, LOCK: MS35338-135, (96906)		EA	2							REF	REF		A8A3E10H3
P-D		WASHER, LOCK: MS35338-135, (96906)		EA	REF							REF	REF		A8A3E10H4
P-D		SOCKET, ELECTRON TUBE: 59-410-1003; (02660)		EA	1							*	*	3-40	A8A3XV3
P-D	5310-206-7021	NUT, PLAIN, HEXAGON: P313-0156-000, (77250)		EA	2							REF	REF		A8A3XV3H1
P-D	5310-208-7021	NUT, PLAIN, HEXAGON: P313-0156-000; (77250)		EA	REF							REF	REF		A8A3XV3H2
P-D	5305-616-2568	SCREW, MACHINE: P343-0285-000, (77250)		EA	2							REF	REF		A8A3XV3H3

REPAIR PARTS FOR DIRECT SUPPORT, GENERAL SUPPORT, AND DEPOT MAINTENANCE (Continued)															
(1) SMR CODE	(2) FEDERAL STOCK NUMBER	(3) DESCRIPTION Reference Number & Mfr. Code Usable on Code		(4) UNIT OF MEAS	(5) QTY INC IN UNIT	(6) 30 DAY DS MAINTENANCE ALLOWANCE			(7) 30 DAY GS MAINTENANCE ALLOWANCE			(8) 1 YR ALW PER 100 EQUIP CNTGCTY	(9) DEPOT MAINT ALW PER 100 EQUIP	(10) ILLUSTRATION	
						(a)	(b)	(c)	(a)	(b)	(c)			(a)	(b)
						1-20	21-50	51-100	1-20	21-50	51-100			FIG NO.	ITEM NO. OR REFERENCE DESIGNATION
P-D	5305-616-2568	SCREW, MACHINE: P33-0285-000, (77250)		EA	REF							REF	REF		A8A3XV3H4
P-D	5310-685-1971	WASHER, SPRING TENSION: 310-0396-00, (79807)		EA	2							REF	REF		ABA3XV3H5
P-D	5310-685-1971	WASHER, SPRING TENSION: 310-0396-00, (79807)		EA	REF							REF	REF		A8A3XV3H6
M-D		SPACER, SLEEVE, SLOTTED: 549-5886-002, (13499)		EA	4										A8A3MP32
M-D		SPACER, SLEEVE, SLOTTED: 549-5886-002, (13499)		EA	REF										A8A3MP33
M-D		SPACER, SLEEVE, SLOTTED: 549-5886-002 (13499)		EA	REF										A8A3MP34
M-D		SPACER, SLEEVE, SLOTTED: 549-5886-002, (13499)		EA	REF										A8A3MP35
M-D	5340-984-7536	SPRING, HELICAL EXTENSION: 549-5868-002, (13499)		EA	2										A8A3MP36
M-D	5340-984-7536	SPRING, HELICAL EXTENSION: 549-5868-002, (13499)		EA	REF										A8A3MP37
M-D		STRIP, SHIELD NO. 1: 756-3175-003; (13499)		EA	1										A8A3E12
M-D		STRIP, SHIELD NO. 2: 756-3176-003, (13499)		EA	1										A8A3E13
M-D		STRIP, SHIELD NO. 3: 756-3177-003; (13499)		EA	1										A8A3E14
P-D	5305-054-5636	SCREW, MACHINE: MS51957-2, (96906)		EA	2							REF	REF		A8A3E13H1
P-D	5305-054-5636	SCREW, MACHINE: MS51957-2, (96906)		EA	REF							REF	REF		A8A3E13H2
P-D	5310-928-2690	WASHER, LOCK: MS35338-134, (96906)		EA	2							REF	REF		A8A3E13H3
P-D	5310-928-2690	WASHER, LOCK: MS35338-134, (96906)		EA	REF							REF	REF		A8A3E13H4
P-D		STRIP, SHIELDING, ELECTRICAL: 548-7792-004, (13499)		EA	1										A8A3E15
P-D	5305-054-5636	SCREW, MACHINE: MS51957-2, (96906)		EA	2							REF	REF		A8A3E15H1
P-D	5305-054-5636	SCREW, MACHINE: MS51957-2, (96906)		EA	REF							REF	REF		A8A3E15H2
P-D	5310-928-2690	WASHER, LOCK: MS35338-134, (96906)		EA	2							REF	REF		A8A3E15H3
P-D	5310-928-2690	WASHER, LOCK: MS35338-134, (96906)		EA	REF							REF	REF		A8A3E15H4
P-D	5820-007-9545	TABLE, ADJUSTABLE SLUG: 549-5893-003, (13499)		EA	1							*	*		A8A3MP38
P-D	5305-054-5647	SCREW, MACHINE: MS51957-13, (96 906)		EA	4							REF	REF		A8A3MP38H1
P-D	5305-054-5647	SCREW, MACHINE: MS51957-13, (96906)		EA	REF							REF	REF		A8A3MP38H2
P-D	5305-054-5647	SCREW, MACHINE: MS51957-13, (96906)		EA	REF							REF	REF		A8A3MP38H3

REPAIR PARTS FOR DIRECT SUPPORT, GENERAL SUPPORT, AND DEPOT MAINTENANCE (Continued)															
(1) SMR CODE	(2) FEDERAL STOCK NUMBER	(3) DESCRIPTION Reference Number & Mfr. Code Usable on Code		(4) UNIT OF MEAS	(5) QTY INC IN UNIT	(6) 30 DAY DS MAINTENANCE ALLOWANCE			(7) 30 DAY GS MAINTENANCE ALLOWANCE			(8) 1 YR ALW PER 100 EQUIP CNTGCTY	(9) DEPOT MAINT ALW PER 100 EQUIP	(10) ILLUSTRATION	
						(a)	(b)	(c)	(a)	(b)	(c)			(a)	(b)
						1-20	21-50	51-100	1-20	21-50	51-100			FIG NO.	ITEM NO. OR REFERENCE DESIGNATION
P-D	5305-054-5647	SCREW, MACHINE: MS51957-13, (96906)		EA	REF							REF	REF		A8A3MP38H4
P-D		WASHER, FLAT-MAIN IDLER: 502-1515-002; (13499)		EA	4							*	*		A8A3MP38H5
P-D		WASHER, FLAT-MAIN IDLER: 502-1515-002; (13499)		EA	REF							REF	REF		A8A3MP38H6
P-D		WASHER, FLAT-MAIN IDLER: 502-1515-002; (13499)		EA	REF							REF	REF		A8A3MP38H7
P-D		WASHER, FLAT-MAIN IDLER: 502-1515-002, (13499)		EA	REF							REF	REF		A8A3MP38H8
P-D	5340-975-T637	POST, ELECTRICAL MECHANICAL: 549-5709-002; (13499)		EA	1							REF	REF		A8A3E16
P-D	5305-616-2568	SCREW, MACHINE: P343-0285-000; (77250)		EA	1							REF	REF		A8A3E16H1
P-D		WASHER, SPRING TENSION: 310-0396-00; (79807)		EA	1							REF	REF		A8A3E16H2
P-D		TERMINAL, LUG: 4007-4HT; (77147)		EA	13										A8A3E17
P-D	5310-93h-9740	NUT, PLAIN HEXAGON: MS35649-225, (96906)		EA	1							REF	REF		A8A3E17H1
P-D	5305-685-7072	SCREW, MACHINE: P330-2284-000, (77250)		EA	1							*	*		A8A3E17H2
P-D	5310-680-5557	WASHER, SPRING TENSION: 310-0075-000, (79807)		EA	1							REF	REF		A8A3E17H3
P-D		TERMINAL, LUG: 4007-4HT, (77147)		EA	REF							REF	REF		A8A3E18
P-D	5310-934-97T0	NUT, PLAIN, HEXAGON: MS35649-225, (96906)		EA	1							REF	REF		A8A3E18H1
P-D	5305-685-7072	SCREW, MACHINE: P330-2284-000, (77250)		EA	1							REF	REF		A8A3E18H2
P-D	5310-680-5557	WASHER, SPRING TENSION: 310-0075-000, (79807)		EA	1							REF	REF		A8A3E18H3
P-D		TERMINAL, LUG: 4007-4HT, (77147)		EA	REF							REF	REF		A8A3E19
P-D	5310-934-9740	NUT, PLAIN, HEXAGON: MS35649-225, (96906)		EA	1							REF	REF		A8A3E19H1
P-D	5305-685-7072	SCREW, MACHINE: P330-2284-000; (77250)		EA	1							REF	REF		A8A3E19H2
P-D	5310-680-5557	WASHER, SPRING TENSION: 310-0075-000, (79807)		EA	1							REF	REF		A8A3E19H3
P-D		TERMINAL, LUG: 4007-4HT, (77147)		EA	REF							REF	REF		A8A3E20
P-D	5310-208-7021	NUT, PLAIN, HEXAGON: P313-0156-000, (77250)		EA	1							REF	REF		A8A3E20H1
P-D		SCREW, MACHINE: P325-0092-000; (77250)		EA	1										A8A3E20H2
P-D		WASHER, SPRING TENSION: 310-0396-00, (79807)		EA	1							REF	REF		A8A3E20H3
P-D		TERMINAL, LUG: 4007-4HT, (77147)		EA	REF							REF	REF		A8A3E21

REPAIR PARTS FOR DIRECT SUPPORT, GENERAL SUPPORT, AND DEPOT MAINTENANCE (Continued)															
(1) SMR CODE	(2) FEDERAL STOCK NUMBER	(3) DESCRIPTION Reference Number & Mfr. Code Usable on Code		(4) UNIT OF MEAS	(5) QTY INC IN UNIT	(6) 30 DAY DS MAINTENANCE ALLOWANCE			(7) 30 DAY GS MAINTENANCE ALLOWANCE			(8) 1 YR ALW PER 100 EQUIP CNTGCTY	(9) DEPOT MAINT ALW PER 100 EQUIP	(10) ILLUSTRATION	
						(a)	(b)	(c)	(a)	(b)	(c)			(a) FIG NO.	(b) ITEM NO. OR REFERENCE DESIGNATION
						1-20	21-50	51-100	1-20	21-50	51-100				
P-D	5310-208-7021	NUT, PLAIN, HEXAGON: P313-0156-000; (77250)		EA	1							REF	REF		A8A3E21H1
P-D	5305-957-6606	SCREW, MACHINE: P325-0092-00; (77250)		EA	1							REF	REF		A8A3E21H2
P-D	5310-685-1971	WASHER, SPRING TENSION: 310-0396-00; (79807)		EA	1							REF	REF		ABA3E21H3
P-D		TERMINAL, LUG: 4007-4HT; (77147)		EA	REF							REF	REF		A8A3E22
P-D		TERMINAL, LUG: 4007-4HT; (77147)		EA	REF							REF	REF		A8A3E23
P-D		TERMINAL, LUG: 4007-4HT; (77147)		EA	REF							REF	REF		A8A3E24
P-D		TERMINAL, LUG: 4007-4HT; (77147)		EA	REF							REF	REF		A8A3E25
P-D		TERMINAL, LUG: 4007-4HT; (77147)		EA	REF							REF	REF		A8A3E26
P-D		TERMINAL, LUG: 4007-4HT; (77147)		EA	REF							REF	REF		A8A3E27
P-D		TERMINAL, LUG: 4007-4HT (77147)		EA	REF							REF	REF		ABA3E28
P-D		TEIAL, LUG: 4007-4HT, (77147)		EA	REF							REF	REF		A8A3E29
P-D	5940-682-2477	TERMINAL, LUG: MS77068-1, (78189)		EA	7										A8A3E30
P-D	5310-208-7021	NUT, PLAIN, HEXAGON: P313-0156-000, (77250)		EA	1							REF	REF		A8A3E30H1
P-D	5305-206-1270	SCREW, MACHINE: P343-0284-000; (77250)		EA	1							REF	REF		A8A3E30H2
P-D	5310-685-1971	WASHER, SPRING TENSION: 310-0396-00; (79807)		EA	1							REF	REF		A8A3E30H3
P-D		TERMINAL, LUG: 2104-04-01-2520M, (78189)		EA	REF							REF	REF		A8A3E31
P-D	5310-208-7021	NUT, PLAIN, HEXAGON: P313-0156-000, (77250)		EA	1							REF	REF		A8A3E31H1
P-D	5305-206-1270	SCREW, MACHINE: P343-0284-000, (77250)		EA	1							REF	REF		A8A3E31H2
P-D	5310-685-1971	WASHER, SPRING TENSION: 310-0396-00, (79807)		EA	1							REF	REF		A8A3E31H3
P-D		TERMINAL, LUG: 2104-04-01-2520N, (78189)		EA	REF							REF	REF		A8A3E32
P-D	5310-208-7021	NUT, PLAIN, HEXAGON: P313-0156-000, (77250)		EA	1							REF	REF		A8A3E32H1
P-D	5305-206-1270	SCREW, MACHINE: P343-0284-000, (77250)		EA	1							REF	REF		A8A3E32H2
P-D	5310-685-1971	WASHER, SPRING TENSION: 310-0396-00, (79807)		EA	1							REF	REF		A8A3E32H3
P-D		TERMINAL, LUG: 2104-04-01-2520N, (78189)		EA	REF							REF	REF		A8A3E33
P-D	5310-208-7021	NUT, PLAIN, HEXAGON: P313-0156-000, (77250)		EA	1							REF	REF		A8A3E33H1

SECTION II

TM 11-5820-509-35

REPAIR PARTS FOR DIRECT SUPPORT, GENERAL SUPPORT, AND DEPOT MAINTENANCE (Continued)															
(1) SMR CODE	(2) FEDERAL STOCK NUMBER	(3) DESCRIPTION Reference Number & Mfr. Code Usable on Code		(4) UNIT OF MEAS	(5) QTY INC IN UNIT	(6) 30 DAY DS MAINTENANCE ALLOWANCE			(7) 30 DAY GS MAINTENANCE ALLOWANCE			(8) 1 YR ALW PER 100 EQUIP CNTGCTY	(9) DEPOT MAINT ALW PER 100 EQUIP	(10) ILLUSTRATION	
						(a)	(b)	(c)	(a)	(b)	(c)			(a) FIG NO.	(b) ITEM NO. OR REFERENCE DESIGNATION
						1-20	21-50	51-100	1-20	21-50	51-100				
P-D	5305-206-1270	SCREW, MACHINE: P343-0284-000, (77250)		EA	1							REF	REF		A8A3E33H2
P-D	5310-685-1971	WASHER, SPRING TENSION: 310-0396-00, (79807)		EA	1							REF	REF		A8A3E33H3
P-D		TERMINAL, LUG: 2104-04-01-2520N, (78189)		EA	REF							REF	REF		A8A3E34
P-D	5310-208-7021	NUT, PLAIN, HEXAGON: P313-0156-000, (77250)		EA	1							REF	REF		A8A3E34H1
P-D	5305-206-1270	SCREW, MACHINE: P343-0284-000, (77250)		EA	1							REF	REF		A8A3E34H2
P-D	5310-685-1971	WASHER, SPRING TENSION: 310-0396-00; (79807)		EA	1							REF	REF		A8A3E34H3
P-D		TERMINAL, LUG: 2104-04-01-2520N, (78189)		EA	REF							REF	REF		A8A3E35
P-D	5310-208-7021	NUT, PLAIN, HEXAGON: P313-0156-000, (77250)		EA	1							REF	REF		A8A3E35H1
P-D	5305-206-1270	SCREW, MACHINE: P343-0284-000, (77250)		EA	1							REF	REF		A8A3E35H2
P-D	5310-685-1971	WASHER, SPRING TENSION: 310-0396-00; (79807)		EA	1							REF	REF		A8A3E35H3
P-D		TERMINAL, LUG: 2104-04-01-2520N; (78189)		EA	REF							REF	REF		A8A3E36
P-D	5310-208-7021	NUT, PLAIN, HEXAGON: P313-0156-000, (77250)		EA	1							REF	REF		A8A3E36H1
P-D	5305-206-1270	SCREW, MACHINE: P343-0284-000, (77250)		EA	1							REF	REF		A8A3E36H2
P-D	5310-685-1971	WASHER, SPRING TENSION: 310-0396-00, (79807)		EA	1							REF	REF		A8A3E36H3
P-D	5940-836-3536	TERMINAL, LUG: 4040-2HDSPL, (77147)		EA	1							REF	REF		A8A3E37
P-D	5310-934-9740	NUT, PLAIN, HEXAGON: MS35669-225, (77250)		EA	1							REF	REF		A8A3E37H1
P-D	5305-616-1815	SCREW, MACHINE: P342-0142-000; (77250)		EA	1										A8A3E37H2
P-D		WASHER, SPRING, TENSION: 310-0075-00, (79807)		EA	1							REF	REF		A8A3E37H3
P-D	5940-455-7441	TERMINAL, LUG: 040-5HDSPL, (77147)		EA	7							REF	REF		A8A3E38
P-D	5310-208-7021	NUT, PLAIN, HEXAGON: P313-0156-000; (77250)		EA	2							REF	REF		A8A3E38H1
P-D	5310-208-7021	NUT, PLAIN, HEXAGON: P313-0156-000; (77250)		EA	REF							REF	REF		A8A3E38H2
P-D	5305-680-9157	SCREW, MACHINE: P347-0007-000, (77250)		EA	1							*	*		A8A3E38H3
P-D	5310-685-1971	WASHER, SPRING, TENSION: 310-0396-00, (79807)		EA	2							REF	REF		A8A3E38H4
P-D	5310-685-1971	WASHER, SPRING, TENSION: 310-0396-00, (79807)		EA	REF							REF	REF		A8A3E38H5
P-D	5940-455-7441	TERMINAL, LUG: 4040-5HDSPL, (77147)		EA	REF							REF	REF		A8A3E39

REPAIR PARTS FOR DIRECT SUPPORT, GENERAL SUPPORT, AND DEPOT MAINTENANCE (Continued)															
(1) SMR CODE	(2) FEDERAL STOCK NUMBER	(3) DESCRIPTION Reference Number & Mfr. Code Usable on Code		(4) UNIT OF MEAS	(5) QTY INC IN UNIT	(6) 30 DAY DS MAINTENANCE ALLOWANCE			(7) 30 DAY GS MAINTENANCE ALLOWANCE			(8) 1 YR ALW PER 100 EQUIP CNTGCTY	(9) DEPOT MAINT ALW PER 100 EQUIP	(10) ILLUSTRATION	
						(a)	(b)	(c)	(a)	(b)	(c)			(a) FIG NO.	(b) ITEM NO. OR REFERENCE DESIGNATION
						1-20	21-50	51-100	1-20	21-50	51-100				
P-D	5940-455-7441	TERMINAL, LUG: 4040-5HDSPL, (77147)		EA	REF							REF	REF		A8A3E40
P-D	5940-455-7441	TERMINAL, LUG: 4040-5HDSPL, (77147)		EA	REF							REF	REF		A8A3E41
P-D	5940-455-7441	TERMINAL, LUG: 4040-5HDSPL, (77147)		EA	REF							REF	REF		A8A3E42
P-D	5940-455-7441	TERMINAL, LUG: 4040-5HDSPL, (77147)		EA	REF							REF	REF		A8A3E43
P-D	5940-455-7441	TERMINAL, LUG: 4040-5HDSPL, (77147)		EA	REF							REF	REF		A8A3E44
P-D	5940-665-5764	TERMINAL, STUD: 2A1DB15, (92825)		EA	2							5	2		A8A3E45
P-D	5305-054-5646	SCREW, MACHINE: MS51957-12, (96906)		EA	2							46	30		A8A3E45H1
P-D	5310-933-8118	WASHER, LOCK: MS35338-135, (96906)		EA	2							REF	REF		A8A3E45H2
P-D	5940-665-5764	TERMINAL, STUD: 2A1DB15, (92825)		EA	REF							REF	REF		A8A3E46
P-D	5305-054-5646	SCREW, MACHINE: MS51957-12, (96906)		EA	REF							REF	REF		A8A3E46H1
P-D		WASHER, LOCK MS35338-135, (96906)		EA	REF							REF	REF		A8A3E46H2
P-D	5940-259-8457	TERMINAL, STUD- RTMT12M, (91663)		EA	1							REF	REF		A8A3E11
P-D		SCREW, MACHINE: P343-0285-000, (77250)		EA	1							REF	REF		A8A3E11H1
P-D	5310-685-1971	WASHER, SPRING, TENSION: 310-0396-00, (79807)		EA	1							REF	REF		A8A3E11H2
P-H-S	5820-977-1565	TRANSLATOR SUBASSEMBLY, SWITCH 549-5959-004, (13499)		EA	1				*	*	*	*	*	3-10	A8A3A9
P-H-T	5820-975-5433	COUPLER, ANTENNA: 549-5924-003, (13499)		EA	1				*	*	*	*	*	3-24	A3A3A9A1
P-D	5305-054-5653	SCREW, MACHINE: MS51957-19, (96906)		EA	4							REF	REF		A8A3A9A1H4
X1-D		BOARD, PRINTED CIRCUIT, SWITCH: 761-5006-001, (13499)		EA	1										A8A3A9A1S1
X1-D		CONTACT ASSEMBLY, ELECTRICAL: 548-7839-003, (13499)		EA	1										A8A3A9A1S1E1
X1-D		NUT, SELF-LOCKING, HEXAGON: 68-1660-26, (72962)		EA	2										A8A3A9A1S1E1H3
X1-D		NUT, SELF-LOCKING, HEXAGON: 68-1660-26, (72962)		EA	REF										A8A3A9A1S1E1H4
X1-D		SCREW, MACHINE: MS51959-3, (96906)		EA	2										A8A3A9A1S1E1H1
X1-D		SCREW, MACHINE: MS51959-3, (96906)		EA	REF										A8A3A9A1S1E1H2
X1-D		CAPACITOR, FIXED, MICA: C405ED200J03, (81349)		EA	1									3-26	A8A3A9A1C10
X1-D		CAPACITOR, FIXED, MICA: CM05ED270G03, (81349)		EA	1									3-26	A8A3A9A1C9

SECTION II

TM 11-5820-509-35

REPAIR PARTS FOR DIRECT SUPPORT, GENERAL SUPPORT, AND DEPOT MAINTENANCE (Continued)															
(1) SMR CODE	(2) FEDERAL STOCK NUMBER	(3) DESCRIPTION Reference Number & Mfr. Code Usable on Code		(4) UNIT OF MEAS	(5) QTY INC IN UNIT	(6) 30 DAY DS MAINTENANCE ALLOWANCE			(7) 30 DAY GS MAINTENANCE ALLOWANCE			(8) 1 YR ALW PER 100 EQUIP CNTGCTY	(9) DEPOT MAINT ALW PER 100 EQUIP	(10) ILLUSTRATION	
						(a)	(b)	(c)	(a)	(b)	(c)			(a) FIG NO.	(b) ITEM NO. OR REFERENCE DESIGNATION
						1-20	21-50	51-100	1-20	21-50	51-100				
X1-D		CAPACITOR, FIXED, MICA: CM05ED300G03, (81349)		EA	1									3-26	A8A3A9A1C8
X1-D		CAPACITOR, FIXED, MICA: CM05ED330G03, (81349)		EA	1									3-26	A8A3A9A1C7
X1-D		CAPACITOR, FIXED, MICA: CM05ED360G03, (81349)		EA	1									3-26	A8A3A9A1C6
X1-D		CAPACITOR, FIXED, MICA: CM05ED430G03, (81349)		EA	1									3-26	A8A3A9A1C5
X1-D		CAPACITOR, FIXED, MICA: CM05ED510G03; (81349)		EA	1									3-26	A8A3A9A1C4
X1-D		CAPACITOR, FIXED, MICA: CM05ED680G03, (81349)		EA	1									3-26	A8A3A9A1C3
X1-D		CAPACITOR, FIXED, MICA: CM05FD101G03, (81349)		EA	1									3-26	A8A3A9A1C2
X1-D		CAPACITOR, FIXED, MICA: CM05FD151G03; (81349)		EA	1									3-26	A8A3A9A1C1
P-D		NUT, SLEEVE: 549-5850-002, (13499)		EA	4						*	*			A8A3A9MP1
P-D		NUT, SLEEVE: 549-5850-002, (13499)		EA	REF						REF	REF			A8A3A9MP2
P-D		NUT, SLEEVE: 549-5850-002; (13499)		EA	REF						REF	REF			A8A3A9MP3
P-D		NUT, SLEEVE: 549-5850-002, (13499)		EA	REF						REF	REF			A8A3A9MP4
M-D		SPACER, SLEEVE: 549-5851-002, (13499)		EA	4										A8A3A9MP5
M-D		SPACER, SLEEVE: 549-5851-002, (13499)		EA	REF										A8A3A9MP6
M-D		SPACER, SLEEVE: 549-5851-002; (13499)		EA	REF										A8A3A9MP7
M-D		SPACER, SLEEVE: 549-5851-002, (13499)		EA	REF										A8A3A9MP8
P-H-T	5820-975-5415	TRANSLATOR SUBASSEMBLY, SWITCH: 549-5925-003, (13499)		EA	1				*	*	*	*	*	3-24	A8A3A9A2
X1-D		BOARD, PRINTED CIRCUIT: 549-5950-004, (13499)		EA	1									3-27	A8A3A9A2S2
X1-D		CONTACT ASSEMBLY, ELECTRICAL: 548-7835-002, (13499)		EA	1										A8A3A9A2S2E1
X1-D		NUT, SELF-LOCKING, HEXAGON: 68-1660-26, (72962)		EA	2										A8A3A9A2S2E1H3
X1-D		NUT, SELF-LOCKING, HEXAGON: 68-1660-26, (72962)		EA	REF										A8A3A9A2S2E1H4
X1-D		SCREW, MACHINE: MS51959-3, (96906)		EA	2										A8A3A9A2S2E1H1
X1-D		SCREW, MACHINE: MS51959-3, (96906)		EA	REF										A8A3A9A2S2E1H2
X1-D		CONTACT ASSEMBLY, ELECTRICAL: 548-7839-003, (13499)		EA	1										A8A3A9A2S2E2
X1-D		CAPACITOR, FIXED, CERAMIC: CC20CH120J, (81349)		EA	1									3-25	A8A3A9A2C32

REPAIR PARTS FOR DIRECT SUPPORT, GENERAL SUPPORT, AND DEPOT MAINTENANCE (Continued)															
(1) SMR CODE	(2) FEDERAL STOCK NUMBER	(3) DESCRIPTION Reference Number & Mfr. Code Usable on Code		(4) UNIT OF MEAS	(5) QTY INC IN UNIT	(6) 30 DAY DS MAINTENANCE ALLOWANCE			(7) 30 DAY GS MAINTENANCE ALLOWANCE			(8) 1 YR ALW PER 100 EQUIP CNTGCTY	(9) DEPOT MAINT ALW PER 100 EQUIP	(10) ILLUSTRATION	
						(a)	(b)	(c)	(a)	(b)	(c)			(a) FIG NO.	(b) ITEM NO. OR REFERENCE DESIGNATION
						1-20	21-50	51-100	1-20	21-50	51-100				
X1-D		CAPACITOR, FIXED, CERAMIC: CC20CH180J, (81349)		EA	1									3-25	A8A3A9A2C31
X1-D		CAPACITOR, FIXED, CERAMIC: CC30UJ680F, (81349)		EA	1									3-25	A8A3A9A2C28
X1-D		CAPACITOR, FIXED, CERAMIC: CC30UJ750F, (81349)		EA	1									3-25	A8A3A9A2C30
X1-D		CAPACITOR, FIXED, CERAMIC: 301-626C0J0309D; (72982)		EA	2									3-25	A8A3A9A2C39
X1-D		CAPACITOR, FIXED, CERAMIC: 301-626C0J0309D, (72982)		EA	REF									3-25	A8A3A9A2C40
X1-D		CAPACITOR, FIXED, CERAMIC: 301-626C0H0409D, (72982)		EA	2									3-24	A8A3A9A2C37
X1-D		CAPACITOR, FIXED, CERAMIC: 301-626C0H0409D, (72982)		EA	REF									3-24	A8A3A9A2C38
X1-D		CAPACITOR, FIXED, CERAMIC: 301-626C0H0509F; (72982)		EA	1									3-24	A8A3A9A2C39
X1-D		CAPACITOR, FIXED, CERAMIC: 301-626C0H0609F, (72982)		EA	1									3-24	A8A3A9A2C35
X1-D		CAPACITOR, FIXED, CERAMIC: 301-626C0H0709F, (72982)		EA	1									3-24	A8A3A9A2C34
X1-D		CAPACITOR, FIXED, CERAMIC: 301-626C0H0909F, (72982)		EA	1									3-25	A8A3A9A2C33
X1-D		CAPACITOR, FIXED, MICA: CM05ED300G03; (81349)		EA	3									3-24	A8A3A9A2C22
X1-D		CAPACITOR, FIXED, MICA: CM05ED300G03; (81349)		EA	REF									3-24	A8A3A9A2C24
X1-D		CAPACITOR, FIXED, MICA: CM05ED300C03, (81349)		EA	REF									3-24	A8A3A9A2C26
X1-D		CAPACITOR, FIXED, MICA: CM05ED560G03, (81349)		EA	1									3-25	A8A3A9A2C27
X1-D		CAPACITOR, FIXED, MICA: CM05ED820G03; (81349)		EA	1									3-25	A8A3A9A2C29
X1-D		CAPACITOR, FIXED, MICA: DM15E271F0300WV4CR, (72136)		EA	1									3-25	A8A3A9A2C12
X1-D		CAPACITOR, FIXED, MICA: DM15E301F0300WV4CR, (72136)		EA	1									3-25	A8A3A9A2C13
X1-D		CAPACITOR, FIXED, MICA: DM15E471F0300WV4CR; (72136)		EA	1									3-25	A8A3A9A2C11
X1-D		CAPACITOR, FIXED, MICA: DM15E251F0500WV4CR; (72136)		EA	1									3-25	A8A3A9A2C15
X1-D		CAPACITOR, FIXED, MICA: DM15E101F0300WV4CR, (72136)		EA	2									3-24	A8A3A9A2C18
X1-D		CAPACITOR, FIXED, MICA: DM15E101F0300WV4CR; (72136)		EA	REF									3-24	A8A3A9A2C19
X1-D		CAPACITOR, FIXED, MICA: DM15E1110F0300WV4CR, (72136)		EA	1									3-25	A8A3A9A2C16
X1-D		CAPACITOR, FIXED, MICA: DM15E1210F0300WV4CR, (72136)		EA	3									3-24	A8A3A9A2C20
X1-D		CAPACITOR, FIXED, MICA: DM15E1210F0300 WV4CR, (72136)		EA	REF									3-24	A8A3A9A2C23

REPAIR PARTS FOR DIRECT SUPPORT, GENERAL SUPPORT, AND DEPOT MAINTENANCE (Continued)															
(1) SMR CODE	(2) FEDERAL STOCK NUMBER	(3) DESCRIPTION Reference Number & Mfr. Code Usable on Code		(4) UNIT OF MEAS	(5) QTY INC IN UNIT	(6) 30 DAY DS MAINTENANCE ALLOWANCE			(7) 30 DAY GS MAINTENANCE ALLOWANCE			(8) 1 YR ALW PER 100 EQUIP CNTGCT	(9) DEPOT MAINT ALW PER 100 EQUIP	(10) ILLUSTRATION	
						(a)	(b)	(c)	(a)	(b)	(c)			(a) FIG NO.	(b) ITEM NO. OR REFERENCE DESIGNATION
						1-20	21-50	51-100	1-20	21-50	51-100				
X1-D		CAPACITOR, FIXED, MICA: DM15E1210F0300WV4CR, (72136)		EA	REF									3-24	A8A3A9A2C25
X1-D		CAPACITOR, FIXED, MICA: DM15E1510F0300WV4CR, (72136)		EA	2									3-24	A8A3A9A2C17
X1-D		CAPACITOR, FIXED, MICA: DM15E1510F0300WV4CR, (72136)		EA	REF									3-24	A8A3A9A2C21
X1-D		CAPACITOR, FIXED, MICA: DM15E1650F0300WV4CR, (72136)		EA	1									3-25	A8A3A9A2C14
X1-D		COIL ASSEMBLY, RADIO FREQUENCY: 549-5889-003, (13 499)		EA	1									3-25	A8A3A9A2E2
X1-D		COIL ASSEMBLY, RADIO FREQUENCY: 549-5890-003, (13499)		EA	1									3-24	A8A3A9A2E1
X1-D		COIL, RADIO FREQUENCY-NO. 1: 549-5931-003, (13499)		EA	1									3-27	A8A3A9A2L17
X1-D		COIL, RADIO FREQUENCY-NO. 3: 549-5933-003, (13499)		EA	1									3-27	A8A3A9A2L18
X1-D		COIL, RADIO FREQUENCY-NO. 5: 549-5935-003, (13499)		EA	1									3-27	A8A3A9A2L19
X1-D		COIL, RADIO FREQUENCY-NO. 6: 549-5936-003; (13499)		EA	1									3-27	A8A3A9A2L20
X1-D		COIL, RADIO FREQUENCY-NO. 7: 549-5937-003, (13499)		EA	1									3-27	A8A3A9A2L21
P-H-S	5820-975-5416	TRANSLATOR SUBASSEMBLY, SWITCH: 549-5926-003, (13499)		EA	1				*	*	*	*	*	3-24	A8A3A9A3
P-D	5305-054-5647	SCREW, MACHINE: MS51957-13; (96906)		EA	4							REF	REF		A8A3A9A3H4
X1-D		BOARD, PRINTED CIRCUIT, SWITCH: 549-5950-004, (13499)		EA	1										A8A3A9A3S3
X1-D		CONTACT ASSEMBLY, ELECTRICAL: 548-7835-003, (13499)		EA	1										A8A3A9A3S3E1
X1-D		NUT, SELF-LOCKING, HEXAGON: 68-1660-26, (72962)		EA	2										A8A3A9A3S3E1H1
X1-D		NUT, SELF-LOCKING, HEXAGON: 68-1660-26, (72962)		EA	REF										A8A3A9A3S3E1H2
X1-D		SCREW, MACHINE: MS51959-3, (96906)		EA	2										A8A3A9A3S3E1H3
X1-D		SCREW, MACHINE: MS51959-3, (96906)		EA	REF										A8A3A9A3S3E1H4
X1-D		CONTACT ASSEMBLY, ELECTRICAL: 548-7839-003, (13499)		EA	1										A8A3A9A3S3E2
X1-D		CAPACITOR, FIXED, CERAMIC: CC20UJ510F, (81349)		EA	1									3-28	A8A3A9A3C6C
X1-D		CAPACITOR, FIXED, CERAMIC: CC30UJ680F, (81349)		EA	1									3-28	A8A3A9A3C58
X1-D		CAPACITOR, FIXED, MICA CM05ED270C03, (81349)		EA	1									3-28	A8A3A9A3C56
X1-D		CAPACITOR, FIXED, MICA: CM05ED330G03, (81349)		EA	1									3-28	A8A3A9A3C54
X1-D		CAPACITOR, FIXED, MICA: CMD5ED60G03, (81349)		EA	1									3-28	A8A3A9A3C44

REPAIR PARTS FOR DIRECT SUPPORT, GENERAL SUPPORT, AND DEPOT MAINTENANCE (Continued)															
(1) SMR CODE	(2) FEDERAL STOCK NUMBER	(3) DESCRIPTION Reference Number & Mfr. Code Usable on Code		(4) UNIT OF MEAS	(5) QTY INC IN UNIT	(6) 30 DAY DS MAINTENANCE ALLOWANCE			(7) 30 DAY GS MAINTENANCE ALLOWANCE			(8) 1 YR ALW PER 100 EQUIP CNTGCTY	(9) DEPOT MAINT ALW PER 100 EQUIP	(10) ILLUSTRATION	
						(a)	(b)	(c)	(a)	(b)	(c)			(a) FIG NO.	(b) ITEM NO. OR REFERENCE DESIGNATION
						1-20	21-50	51-100	1-20	21-50	51-100				
X1-D		CAPACITOR, FIXED, MICA: CM05ED620G03, (81349)		EA	1									3-28	A8A3A9A3C48
X1-D		CAPACITOR, FIXED, MICA: CM05ED680G03, (81349)		EA	3									3-28	A8A3A9A3C50
X1-D		CAPACITOR, FIXED, MICA: CM05ED680G03; (81349)		EA	REF									3-28	A8A3A9A3C52
X1-D		CAPACITOR, FIXED, MICA: CM05ED680G03, (81349)		EA	REF									3-28	A8A3A9A3C57
X1-D		CAPACITOR, FIXED, MICA: CM05ED750G03, (81349)		EA	1									3-28	A8A3A9A3C46
X1-D		CAPACITOR, FIXED, MICA: CM05ED820G03; (81349)		EA	1									3-28	A8A3A9A3C59
X1-D		CAPACITOR, FIXED, MICA: DM15E511F0300WV4CR, (72136)		EA	1									3-28	A8A3A9A3C41
X1-D		CAPACITOR, FIXED, MICA: DM15E271F0300WV4CR, (72136)		EA	2									3-28	A8A3A9A3C42
X1-D		CAPACITOR, FIXED, MICA: DM15E271F0300WV4CR, (72136)		EA	REF									3-28	A8A3A9A3C45
X1-D		CAPACITOR, FIXED, MICA: DM15E471F0300WV4CR, (72136)		EA	1									3-28	A8A3A9A3C43
X1-D		CAPACITOR, FIXED, MICA: DM15E1330F0500WV4CR, (72136)		EA	1									3-28	A89A9A3C49
X1-D		CAPACITOR, FIXED, MICA: DM15E191F0500WV4CR; (72136)		EA	1									3-28	A8A3A9A3C47
X1-D		CAPACITOR, FIXED, MICA: DM15E101F0300FWV4CR, (72136)		EA	1									3-28	A8A3A9A3C51
X1-D		CAPACITOR, FIXED, MICA: DM151110F0300WV4CR, (72136)		EA	2									3-28	A8A3A9A3C53
X1-D		CAPACITOR, FIXED, MICA: DM15E1110F0300WV4CR, (72136)		EA	REF									3-28	A8A3A9A3C55
X1-D		COIL ASSEMBLY, RADIO FREQUENCY: 549-5889-003; (13499)		EA	1									3-28	A8A3A9A3E4
X1-D		COIL ASSEMBLY, RADIO FREQUENCY: 549-5890-003, (13499)		EA	1									3-28	A8A3A9A3E3
X1-D		COIL, RADIO FREQUENCY-NO. 1: 549-5931-003; (13499)		EA	1									3-28	A8A3A9A3E32
X1-D		COIL, RADIO FREQUENCY-NO. 3: 549-5933-003; (13499)		EA	1									3-28	A8A3A9A3E33
X1-D		COIL, RADIO FREQUENCY-NO. 5: 549-5935-003, (13499)		EA	1									3-28	A8A3A9A3E34
X1-D		COIL, RADIO FREQUENCY-NO. 6: 549-5936-003, (13499)		EA	1									3-28	A8A3A9A3E35
X1-D		COIL, RADIO FREQUENCY-NO. 7: 549-5937-003, (13499)		EA	1									3-28	A8A3A9A3E36
P-H-T	5820-975-5414	TRANSLATOR SUBASSEMBLY: 549-5927-003, (13499)		EA	1				*	*	*	*	*	3-10	A8A3A10
X1-D		BOARD, PRINTED CIRCUIT: 549-5950-004, (13499)		EA	1									3-29	A8A3A10S4
X1-D		CONTACT ASSEMBLY, ELECTRICAL: 548-7835-002, (13499)		EA	1										A8A3A10S4E1

REPAIR PARTS FOR DIRECT SUPPORT, GENERAL SUPPORT, AND DEPOT MAINTENANCE (Continued)															
(1) SMR CODE	(2) FEDERAL STOCK NUMBER	(3) DESCRIPTION Reference Number & Mfr. Code Usable on Code		(4) UNIT OF MEAS	(5) QTY INC IN UNIT	(6) 30 DAY DS MAINTENANCE ALLOWANCE			(7) 30 DAY GS MAINTENANCE ALLOWANCE			(8) 1 YR ALW PER 100 EQUIP CNTGCTY	(9) DEPOT MAINT ALW PER 100 EQUIP	(10) ILLUSTRATION	
						(a)	(b)	(c)	(a)	(b)	(c)			(a) FIG NO.	(b) ITEM NO. OR REFERENCE DESIGNATION
						1-20	21-50	51-100	1-20	21-50	51-100				
X1-D		NUT, SELF-LOCKING, HEXAGON: 68-1660-26, (72962)		EA	2										A8A3A10S4E1H3
X7-D		NUT, SELF-LOCKING, HEXAGON: 68-1660-26; (72962)		EA	REF										A8A3A10S4E1H4
X1-D		SCREW, MACHINE: MS51959-3, (96906)		EA	2										A8A3A10S4E1H1
X1-D		SCREW, MACHINE: MS51959-3, (96906)		EA	REF										A8A3A10S4E1H2
X1-D		CONTACT ASSEMBLY, ELECTRICAL: 548-7839-003, (13499)		EA	1										A8A3A10S4E2
X1-D		CAPACITOR, FIXED, CERAMIC: CC20UJ510F; (81349)		EA	1								3-29		ABA3A10C85
X1-D		CAPACITOR, FIXED, MICA: CERAMIC: CC30UJ750F; (81349)		EA	1								3-29		A8A3A10C87
X1-D		CAPACITOR, FIXED, MICA: CM05ED270G03, (81349)		EA	1								3-29		A8A3A10C81
X1-D		CAPACITOR, FIXED, MICA: CM05ED330G03; (81349)		EA	2								3-29		A8A3A10C77
X1-D		CAPACITOR, FIXED, MICA: CR05ED330G03; (81349)		EA	REF								3-29		A8A3A10C83
X1-D		CAPACITOR, FIXED, MICA: CM05ED390G03; (81349)		EA	1								3-29		A8A3A10C79
X1-D		CAPACITOR, FIXED, MICA: CM05ED750G03; (81349)		EA	1								3-29		A8A3A10C75
X1-D		CAPACITOR, FIXED, MICA: CM05ED820G03; (81349)		EA	1								3-29		A8A3A10C86
X1-D		CAPACITOR, FIXED, MICA: CM05FD181G03; (81349)		EA	1								3-29		A8A3A10C71
X1-D		CAPACITOR, FIXED, MICA: DM15E511F0300WV4CR; (72136)		EA	1								3-29		A8A3A10C68
X1-D		CAPACITOR, FIXED, MICA: DM15E221F0300WV4CR; (72136)		EA	1								3-29		A8A3A10C77
X1-D		CAPACITOR, FIXED, MICA: DM15E271F0300WV4CR; (72136)		EA	1								3-29		A8A3A10C72
X1-D		CAPACITOR, FIXED, MICA: DM15E33F0300WV4CR; (72136)		EA	1								3-29		A8A3A10C69
X1-D		CAPACITOR, FIXED, MICA: DM15E361F0300WV4CR; (72136)		EA	1								3-29		A8A3A10C70
X1-D		CAPACITOR, FIXED, MICA: DM15E141F0500WV4CR; (72136)		EA	1								3-29		A8A3A10C80
X1-D		CAPACITOR, FIXED, MICA: D105E1110F300WV4CR; (72136)		EA	1								3-29		A8A3A10C84
X1-D		CAPACITOR, FIXED, MICA: DM15E1210F300WV4CR; (72136)		EA	2								3-29		A8A3A10C73
X1-D		CAPACITOR, FIXED, MICA: D15E1210F0300WV4CR; (72136)		EA	REF								3-29		A8A3A10C82
X1-D		CAPACITOR, FIXED, MICA: DN15E1650F0300W VCR; (72136)		EA	1								3-29		A8A3A10C78
X1-D		CAPACITOR, FIXED, MICA: DN15E1910F0300WVCR; (72136)		EA	1								3-29		A8A3A10C76

REPAIR PARTS FOR DIRECT SUPPORT, GENERAL SUPPORT, AND DEPOT MAINTENANCE (Continued)															
(1) SMR CODE	(2) FEDERAL STOCK NUMBER	(3) DESCRIPTION Reference Number & Mfr. Code Usable on Code		(4) UNIT OF MEAS	(5) QTY INC IN UNIT	(6) 30 DAY DS MAINTENANCE ALLOWANCE			(7) 30 DAY GS MAINTENANCE ALLOWANCE			(8) 1 YR ALW PER 100 EQUIP CNTGCTY	(9) DEPOT MAINT ALW PER 100 EQUIP	(10) ILLUSTRATION	
						(a)	(b)	(c)	(a)	(b)	(c)			(a) FIG NO.	(b) ITEM NO. OR REFERENCE DESIGNATION
						1-20	21-50	51-100	1-20	21-50	51-100				
X1-D		COIL ASSEMBLY, RADIO FREQUENCY: 549-5689-003; (13499)	EA	1										3-29	A8A3A10E6
X1-D		COIL ASSEMBLY, RADIO FREQUENCY: 549-5890-003, (1399)	EA	1										3-29	ASA3A10E5
X1-D		COIL, RADIO FREQUENCY-NO. 1: 549-5931-003; (13499)	EA	1										3-29	A8A3A10L47
X1-D		COIL, RADIO FREQUENCY-NO. 3: 549-5933-003; (13499)	EA	1										3-29	A8A3A10L48
X1-D		COIL, RADIO FREQUENCY-NO. 5: 549-5935-003; (13499)	EA	1										3-29	A8A3A10L49
X1-D		COIL, RADIO FREQUENCY-NO. 6: 549-5936-003, (13499)	EA	1										3-29	A8A3A10L50
X1-D		COIL, RADIO FREQUENCY-NO. 7: 549-5937-003, (13499)	EA	1										3-29	A8A3A10L51
P-H-T	5820-975-5413	TRANSLATOR SUBASSEMBLY, RF: 549-5928-003, (13499)	EA	1				*	*	*	*	*		3-10	A8A3A11
X1-D		BOARD, PRINTED CIRCUIT: 549-5950-004, (13499)	EA	1										3-30	A8A3A11S5
X1-D		CONTACT ASSEMBLY, ELECTRICAL: 548-7835-002; (13499)	EA	1											A8A3A11S5E1
X1-D		SCREW, MACHINE: MS51959-3; (96906)	EA	2											A8A3A11S5E1H1
X1-D		SCREW, MACHINE: MS51959-3; (96906)	EA	REF											A8A3A11S5E1H2
X1-D		NUT, SELF-LOCKING, HEXAGON: 68-1660-26, (72962)	EA	2											A8A3A11S5E1H3
X1-D		NUT, SELF-LOCKING, HEXAGON: 68-1660-26, (72962)	EA	REF											A8A3A11S5E1H4
X1-D		CONTACT ASSEMBLY, ELECTRICAL: 548-7839-003, (13499)	EA	1											A8A3A11S5E2
X1-D		CAPACITOR, FIXED, CERAMIC: CC20UJ620F, (81349)	EA	2										3-30	A8A3A11C112
X1-D		CAPACITOR, FIXED, CERAMIC: CC20UJ620F, (81349)	EA	REF										3-30	A8A3A11C114
X1-D		CAPACITOR, FIXED, MICA: CM05ED270G03, (81349)	EA	2										3-30	A8A3A11C104
X1-D		CAPACITOR, FIXED, MICA: CM05ED270G03, (81349)	EA	REF										3-30	A8A3A11C110
X1-D		CAPACITOR, FIXED, MICA: CM05RD430G03; (81349)	EA	1										3-30	A8A3A11C108
X1-D		CAPACITOR, FIXED, MICA: CM05ED510G03, (81349)	EA	1										3-30	A8A3A11C111
X1-D		CAPACTTOR, FIXED, MICA: CMD5ED560G03, (8134 9)	EA	1										3-30	A8A3A11C98
X1-D		CAPACITOR, FIXED, MICA: CM05ED620G03; (81349)	EA	3										3-30	A8A3A11C100
X1-D		CAPACITOR, FIXED, MICA: CM05ED620G03, (81349)	EA	REF										3-30	A8A3A11C106
X1-D		CAPACITOR, FIXED, MICA: CM05ED620G03; (81349)	EA	REF										3-30	A8A3A11C113

REPAIR PARTS FOR DIRECT SUPPORT, GENERAL SUPPORT, AND DEPOT MAINTENANCE (Continued)															
(1) SMR CODE	(2) FEDERAL STOCK NUMBER	(3) DESCRIPTION Reference Number & Mfr. Code Usable on Code		(4) UNIT OF MEAS	(5) QTY INC IN UNIT	(6) 30 DAY DS MAINTENANCE ALLOWANCE			(7) 30 DAY GS MAINTENANCE ALLOWANCE			(8) 1 YR ALW PER 100 EQUIP CNTGCTY	(9) DEPOT MAINT ALW PER 100 EQUIP	(10) ILLUSTRATION	
						(a)	(b)	(c)	(a)	(b)	(c)			(a) FIG NO.	(b) ITEM NO. OR REFERENCE DESIGNATION
						1-20	21-50	51-100	1-20	21-50	51-100				
X1-D		CAPACITOR, FIXED, MICA: CM05FD910G03; (81349)	EA	1									3-30	A8A3A11C102	
X1-D		CAPACITOR, FIXED, MICA: DM15E511F0300WV4CR; (72136)	EA	1									3-30	A8A3A11C95	
X1-D		CAPACITOR, FIXED, MICA: DM15E271F0300WV4CR; (72136)	EA	2									3-30	A8A3A11C96	
X1-D		CAPACITOR, FIXED, MICA: DM15E271F0300WV4CR; (72136)	EA	REF									3-30	A8A3A11C99	
X1-D		CAPACITOR, FIXED, MICA: DM15E431F0300WV4CR; (72136)	EA	1									3-30	A8A3A11C97	
X1-D		CAPACITOR, FIXED, MICA: DM15E101F0300WV4CR; (72136)	EA	2									3-30	A8A3A11C105	
X1-D		CAPACITOR, FIXED, MICA: DM15E101F0300WV4CR; (72136)	EA	REF									3-30	A8A3A11C107	
X1-D		CAPACITOR, FIXED, MICA: DM15E1650F0300WV4CR; (72136)	EA	2									3-30	A8A3A11C101	
X1-D		CAPACITOR, FIXED, MICA: DM15E1650F0300WV4CR; (72136)	EA	REF									3-30	A8A3A11C103	
X1-D		CAPACITOR, FIXED, MICA: DM15E960F0500WV4CR; (72136)	EA	1									3-30	A8A3A11C109	
X1-D		COIL ASSEMBLY, RADIO FREQUENCY: 549-5889-003; (13499)	EA	1									3-30	A8A3A11E8	
X1-D		COIL ASSEMBLY, RADIO FREQUENCY: 549-5890-003; (13499)	EA	1									3-30	A8A3A11E7	
X1-D		COIL, RADIO FREQUENCY-NO. 1: 549-5931-003; (13499)	EA	1									3-30	A8A3A11L62	
X1-D		COIL, RADIO FREQUENCY-NO. 3: 549-5933-003; (13499)	EA	1									3-30	A8A3A11L63	
X1-D		COIL, RADIO FREQUENCY-NO. 5: 549-5935-003; (13499)	EA	1										A8A3A11L64	
X1-D		COIL, RADIO FREQUENCY-NO. 6: 549-5936-003; (13499)	EA	1									3-30	A8A3A11L65	
X1-D		COIL, RADIO REQUEIICY-NO. 7: 549-5937-003; (13499)	EA	1									3-30	A8A3A11L66	
P-H-T	5820-795-9365	TRANSLATOR SUBASSEMBLY, SWITCH 756-3164-003; (13499)	EA	1				*	*	*	*	*		A8A3A12	
X1-D		BOARD, PRINTED CIRCUIT, SWITCH: 549-5950-003; (13499)	EA	1									3-35	A8A3A12S8	
X1-D		CONTACT ASSEMBLY, ELECTRICAL: 548-7835-002; (13499)	EA	1										A8A3A12S8E1	
X1-D		NUT, SELF-LOCKING, HEXAGON: 68-1660-26; (72962)	EA	2										A8A3A12S8E1H1	
X1-D		NUT, SELF-LOCKING, HEXAGON: 68-1660-26; (72962)	EA	REF										A8A3A12S8E1H2	
X1-D		SCREW, MACHINE: MS51959-3; (96906)	EA	2										A8A3A12S8E1H3	
X1-D		SCREW, MACHINE: MS51959-3; (96906)	EA	REF										A8A3A12S8E1H4	
X1-D		CONTACT ASSEMBLY, ELECTRICAL: 548-7839-003; (13499)	EA	1										A8A3A12S8E2	

REPAIR PARTS FOR DIRECT SUPPORT, GENERAL SUPPORT, AND DEPOT MAINTENANCE (Continued)															
(1) SMR CODE	(2) FEDERAL STOCK NUMBER	(3) DESCRIPTION Reference Number & Mfr. Code Usable on Code		(4) UNIT OF MEAS	(5) QTY INC IN UNIT	(6) 30 DAY DS MAINTENANCE ALLOWANCE			(7) 30 DAY GS MAINTENANCE ALLOWANCE			(8) 1 YR ALW PER 100 EQUIP CNTGCTY	(9) DEPOT MAINT ALW PER 100 EQUIP	(10) ILLUSTRATION	
						(a)	(b)	(c)	(a)	(b)	(c)			(a)	(b)
						1-20	21-50	51-100	1-20	21-50	51-100			FIG NO.	ITEM NO. OR REFERENCE DESIGNATION
X1-D		CAPACITOR, FIXED, CERAMIC: CC20UJ510F, (81349)		EA	2									3-35	A8A3A12C139
X1-D		CAPACITOR, FIXED, CERAMIC: CC20UJ510F, (81349)		EA	REF									3-35	A8A3A12C141
X1-D		CAPACITOR, FIXED, MICA: CM05ED560G03; (81349)		EA	1									3-35	A8A3A12C137
X1-D		CAPACITOR, FIXED, MICA: CM05ED750G03, (81349)		EA	2									3-35	A8A3A12C135
X1-D		CAPACITOR, FIXED, MICA: CM05ED750G03, (81349)		EA	REF									3-35	A8A3A12C140
X1-D		CAPACITOR, FIXED, MICA: CM05FD910G03, (81349)		EA	2									3-35	A8A3A12C129
X1-D		CAPACITOR, FIXED, MICA: CM05FD910G03, (81349)		EA	REF									3-35	A8A3A12C138
X1-D		CAPACITOR, FIXED, MICA: CM05FD391G03; (81349)		EA	1									3-35	A8A3A12C122
X1-D		CAPACITOR, FIXED, MICA: DM15E511F0300WV4CR, (72136)		EA	1									3-35	A8A3A12C124
X1-D		CAPACITOR, FIXED, MICA: DM15E221F0300WV4CR, (72136)		EA	1									3-35	A8A3A12C128
X1-D		CAPACITOR, FIXED, MICA: DM15E271F0300WVCR, (72136)		EA	1									3-35	A8A3A12C126
X1-D		CAPACITOR, FIXED, MICA: DM15E1330F0500WV4CR, (72136)		EA	1									3-35	A8A3A12C130
X1-D		CAPACITOR, FIXED, MICA: DM15E681G0300WV4CR, (72136)		EA	1									3-35	A8A3A12C123
X1-D		CAPACITOR, FIXED, MICA: DM15E101F0300WV4CR, (72136)		EA	4									3-35	A8A3A12C132
X1-D		CAPACITOR, FIXED, MICA: DM15E101F0300WV4CR, (72136)		EA	REF									3-35	A8A3A12C133
X1-D		CAPACITOR, FIXED, MICA: DM15E101F0300WV4CR; (72136)		EA	REF									3-35	A8A3A12C134
X1-D		CAPACITOR, FIXED, MICA: DM15E101F0300WV4CR, (72136)		EA	REF									3-35	A8A3A12C136
X1-D		CAPACITOR, FIXED, MICA: DM15E110F0300WV4CR, (72136)		EA	1									3-35	A8A3A12C131
X1-D		CAPACITOR, FIXED, MICA: DM15E151F0300WV4CR, (72136)		EA	1									3-35	A8A3A12C127
X1-D		CAPACITOR, FIXED, MICA: DM15E1650F0300WV4CR, (72136)		EA	1									3-35	A8A3A12C125
X1-D		COIL ASSEMBLY, RADIO FREQUENCY: 549-5889-003; (13499)		EA	1									3-35	A8A3A12E12
X1-D		COIL ASSEMBLY, RADIO FREQUENCY: 549-5890-003, (13499)		EA	1									3-35	A8A3A12E11
X1-D		COIL, RADIO FREQUENCY-NO. 1: 549-5931-003, (13499)		EA	1									3-35	A8A3A12L79
X1-D		COIL, RADIO FREQUENCY-NO. 2: 549-5932-003, (13499)		EA	1									3-35	A8A3A12L80
X1-D		COIL, RADIO FREQUENCY-NO. 3: 549-5933-003, (13499)		EA	1									3-35	A8A3A12L81

REPAIR PARTS FOR DIRECT SUPPORT, GENERAL SUPPORT, AND DEPOT MAINTENANCE (Continued)																
(1) SMR CODE	(2) FEDERAL STOCK NUMBER	(3) DESCRIPTION Reference Number & Mfr. Code Usable on Code		(4) UNIT OF MEAS	(5) QTY INC IN UNIT	(6) 30 DAY DS MAINTENANCE ALLOWANCE			(7) 30 DAY GS MAINTENANCE ALLOWANCE			(8) 1 YR ALW PER 100 EQUIP CNTGCT	(9) DEPOT MAINT ALW PER 100 EQUIP	(10) ILLUSTRATION		
						(a)	(b)	(c)	(a)	(b)	(c)			(a) FIG NO.	(b) ITEM NO. OR REFERENCE DESIGNATION	
						1-20	21-50	51-100	1-20	21-50	51-100					
X1-D	5820-975-5431	COIL, RADIO FREQUENCY-NO. 8: 756-3166-003, (13499)		EA	1									3-35	A8A3A12L78	
X1-D		COIL, RADIO FREQUENCY-NO. 9: 756-3167-003; (13499)		EA	1										3-35	A8A3A12L77
P-H-T		TRANSLATOR SUBASSEMBLY: 549-5908-003; (13499)		EA	1										3-10	A8A3A13
X1-D		CAPACITOR, FIXED, MICA: DM15C100K500WVRCR, (72136)		EA	2										3-36	A8A3A13C265
X1-D		CAPACITOR, FIXED, MICA: DM15C100K500WVRCR, (72136)		EA	REF										3-36	A8A3A13C267
X1-D		CAPACITOR, FIXED, MICA: CM05ED200J03, (81349)		EA	1										3-36	A8A3A13C263
X1-D		CAPACITOR, FIXED, MICA: CM05ED270J03, (81349)		EA	1										3-36	A8A3A13C261
X1-D		CAPACITOR, FIXD, MICA: CM05ED390G03; (81349)		EA	1										3-36	A8A3A13C259
X1-D		CAPACITOR, FIXED, MICA: CM05ED620G03, (81349)		EA	1										3-36	A8A3A13C257
X1-D		CAPACITOR, FIXED, MICA: CM05FD910G03, (81349)		EA	1										3-36	A8A3A13C255
X1-D		CAPACITOR, FIXED, MICA: DM15E1330F0500WV4CR; (72136)		EA	1										3-36	A8A3A13C253
X1-D		CAPACITOR, FIXED, MICA: DM15E2870F0500WV4CR, (72136)		EA	1										3-36	A8A3A13C249
X1-D		CAPACITOR, FIXED, MICA: DM15E1650F0300WV4CR, (72136)		EA	1										3-36	A8A3A13C251
X1-D		CAPACITOR, VARIABLE, CERAMIC: 557-099-5-30E, (72982)		EA	6										3-36	A8A3A13C254
X1-D		CAPACITOR, VARIABLE, CERAMIC: 557-099-5-30E, (72982)		EA	REF										3-36	A8A3A13C256
X1-D		CAPACITOR, VARIABLE, CERAMIC: 557-099-5-30E, (72982)		EA	REF										3-36	A8A3A13C258
X1-D		CAPACITOR, VARIABLE, CERAMIC: 557-099-5-30E, (72982)		EA	REF										3-36	A8A3A13C260
X1-D		CAPACITOR, VARIABLE, CERAMIC: 557-099-5-30E, (72982)		EA	REF										3-36	A8A3A13C262
X1-D		CAPACITOR, VARIABLE, CERAMIC: 557-099-5-30E, (72982)		EA	REF										3-36	A8A3A13C264
X1-D		CAPACITOR, VARIABLE, CERAMIC: 557-099-5-30E, (72982)		EA	1										3-36	A8A3A13C266
X1-D		CAPACITOR, VARIABLE, CERAMIC: 557-099-5-25A, (72982)		EA	3										3-36	A8A3A13C248
X1-D		CAPACITOR, VARIABLE, CERAMIC: 557-099-8-50E; (72982)		EA	REF										3-36	A8A3A13C260
X1-D		CAPACITOR, VARIABLE, CERAMIC: 557-099-8-50E, (72982)		EA	REF										3-36	A8A3A13C252
X1-D		CLAMP, CABLE: 549-5643-002, (13499)		EA	1											A8A3A13MP1
X1-D		SCREW, MACHINE: P343-0286-000, (77250)		EA	1											A8A3A13MP1H1

REPAIR PARTS FOR DIRECT SUPPORT, GENERAL SUPPORT, AND DEPOT MAINTENANCE (Continued)															
(1) SMR CODE	(2) FEDERAL STOCK NUMBER	(3) DESCRIPTION Reference Number & Mfr. Code Usable on Code		(4) UNIT OF MEAS	(5) QTY INC IN UNIT	(6) 30 DAY DS MAINTENANCE ALLOWANCE			(7) 30 DAY GS MAINTENANCE ALLOWANCE			(8) 1 YR ALW PER 100 EQUIP CNTGCTY	(9) DEPOT MAINT ALW PER 100 EQUIP	(10) ILLUSTRATION	
						(a)	(b)	(c)	(a)	(b)	(c)			(a) FIG NO.	(b) ITEM NO. OR REFERENCE DESIGNATION
						1-20	21-50	51-100	1-20	21-50	51-100				
X1-D		COIL, RADIO FREQUENCY: 549-5885-002, (13499)		EA	1									3-36	A8A3A13L103
X1-D		SWITCH SUBASSEMBLY: 549-5951-000, (13499)		EA	1										A8A3A13S9
P-D		TUBE, ELECTRON: 7905; (49956)		EA	1						*	*		3-9	A8A3V3
M-D	5820-977-6242	WEDGE-TAPE: 549-5863-002, (13499)		EA	2										A8A3MP39
P-D		SCREW, MACHINE: MS51959-3, (96906)		EA	2						REF	REF			A8A3MP39H1
P-D		SCREW, MACHINE: MS51959-3, (96906)		EA	REF						REF	REF			A8A3MP39H2
M-D	5820-977-6242	WEDGE-TAPE: 549-5863-002; (13499)		EA	REF										A8A3MP40
P-D		SCREW, MACHINE: MS51959-3, (96906)		EA	2						REF	REF			A8A3MP40H1
P-D		SCREW, MACHINE: MS51959-3, (96906)		EA	REF						REF	REF			A8A3MP40H2
P-D		WASHER: 553-5032-003, (13499)		EA	10						*	*			A8A3H9
P-D		WASHER: 553-5032-003; (13499)		EA	REF						REF	REF			A8A3H10
P-D		WASHER: 553-5032-003, (13499)		EA	REF						REF	REF			A8A3H11
P-D		WASHER: 553-5032-003, (13499)		EA	REF						REF	REF			A8A3H12
P-D		WASHER: 553-5032-003, (13499)		EA	REF						REF	REF			A8A3H13
P-D		WASHER: 553-5032-003, (13499)		EA	REF						REF	REF			A8A3H14
P-D		WASHER: 553-5032-003, (13499)		EA	REF						REF	REF			A8A3H15
P-D		WASHER: 553-5032-003, (13499)		EA	REF						REF	REF			A8A3H16
P-D		WASHER: 553-5032-003, (13499)		EA	REF						REF	REF			A8A3H17
P-D		WASHER: 553-5032-003, (13499)		EA	REF						REF	REF			A8A3H18
P-H-S	5820-087-2299	AMPLIFIER, AUDIO FREQUENCY: AM3506PRC47, (80058)		EA	1				*	*	*	*	*	3-4	A8A1
P-H-T	5820-087-3439	AMPLIFIER SUBASSEMBLY, AF: 549-5651-004, (13499)		EA	1				*	*	*	*	*	3-6	A8A1E2
P-D		SCREW, MACHINE MS51959-3, (96906)		EA	6						REF	REF			A8A1E2H6
X1-D		BOARD, PRINTED CIRCUIT 549-5653-004, (13499)		EA	1									3-18	A8A1E2E1
X1-D		CAPACITOR, FIXED, ELECTROLYTIC 150D156X0C20B2, (56289)		EA	1									3-18	A8A1E2C5
X1-D		CAPACITOR, FIXED, ELECTROLYTIC. 150D226X0015B2, (56289)		EA	1									3-18	A8A1E2C9

REPAIR PARTS FOR DIRECT SUPPORT, GENERAL SUPPORT, AND DEPOT MAINTENANCE (Continued)															
(1) SMR CODE	(2) FEDERAL STOCK NUMBER	(3) DESCRIPTION Reference Number & Mfr. Code Usable on Code		(4) UNIT OF MEAS	(5) QTY INC IN UNIT	(6) 30 DAY DS MAINTENANCE ALLOWANCE			(7) 30 DAY GS MAINTENANCE ALLOWANCE			(8) 1 YR ALW PER 100 EQUIP CNTGCTY	(9) DEPOT MAINT ALW PER 100 EQUIP	(10) ILLUSTRATION	
						(a)	(b)	(c)	(a)	(b)	(c)			(a) FIG NO.	(b) ITEM NO. OR REFERENCE DESIGNATION
						1-20	21-50	51-100	1-20	21-50	51-100				
X1-D		CAPACITOR, FIXED, ELECTROLYTIC: 150D476X0006B2, (56289)		EA	2									3-18	A8A1E2C3
X1-D		CAPACITOR, FIXED, ELECTROLYTIC: 150D476X0006B2; (56289)		EA	REF									3-18	A8A1E2C4
X1-D		CAPACITOR, FIXED, ELECTROLYTIC: 150D476X0035S2, (56289)		EA	1									3-18	A8A1E2C16
X1-D		CAPACITOR, FIXED, ELECTROLYTIC: 150D107X0020S2, (56289)		EA	2									3-18	A8A1E2C8
X1-D		CAPACITOR, FIXED, ELECTROLYTIC: 150D107XOD20S2, (56289)		EA	REF									3-18	A8A1E2C12
X1-D		CAPACITOR, FIXED, ELECTROLYTIC: 150D156X0035R2, (56289)		EA	1									3-18	A8A1E2C2
X1-D		CAPACITOR, FIXED, ELECTROLYTIC: 150D476X0020R2, (56289)		EA	7									3-18	A8A1E2C6
X1-D		CAPACITOR, FIXED, ELECTROLYTIC: 150D476X0020R2, (56289)		EA	REF									3-18	A8A1E2C7
X1-D		CAPACITOR, FIXED, ELECTROLYTIC: 150D476X0020R2, (56289)		EA	REF									3-18	A8A1E2C10
X1-D		CAPACITOR, FIXED, ELECTROLYTIC: 150D476X0020R2, (56289)		EA	REF									3-18	A8A1E2C11
X1-D		CAPACITOR, FIXED, ELECTROLYTIC: 150D476X0020R2, (56289)		EA	REF									3-18	A8A1E2C13
X1-D		CAPACITOR, FIXED, ELECTROLYTIC: 150D476X0020R2, (56289)		EA	REF									3-18	A8A1E2C14
X1-D		CAPACITOR, FIXED, ELECTROLYTIC: 150D476X0020R2, (56 289)		EA	REF									3-18	A8A1E2C15
X1-D		INSULATOR, TRANSISTOR: T1566, (98291)		EA	4										A8A1E2E2
X1-D		INSULATOR, TRANSISTOR: T1566; (98291)		EA	REF										A8A1E2E3
X1-D		INSULATOR, TRANSISTOR: T1566, (98291)		EA	REF										A8A1E2E4
X1-D		INSULATOR, TRANSISTOR: T1566, (98291)		EA	REF										A8A1E2E5
X1-D		JACK, TIP: 105-732-100; (74970)		EA	1									3-18	A8A1E2J2
X1-D		JACK, TIP: 105-738-100, (74970)		EA	1									3-18	A8A1E2J1
X1-D		JACK, TIP: 105-734-100, (74970)		EA	1									3-18	A8A1E2J6
X1-D		JACK, TIP: 105-736-100, (74970)		EA	1									3-18	A8A1E2J3
X1-D		JACK, TIP: 105-740-100, (74970)		EA	1									3-18	A8A1E2J6
X1-D		JACK, TIP: 105-737-100, (7497)		EA	1									3-18	A8A1E2J4
X1-D		JACK, TIP 119437K., (78947)		EA	1									3-18	A8A1E2J7
X1-D		RESISTOR, FIXED, COMPOSITION RCR07G101KS, (81349)		EA	1									3-18	A8A1E2R1

REPAIR PARTS FOR DIRECT SUPPORT, GENERAL SUPPORT, AND DEPOT MAINTENANCE (Continued)															
(1) SMR CODE	(2) FEDERAL STOCK NUMBER	(3) DESCRIPTION Reference Number & Mfr. Code Usable on Code		(4) UNIT OF MEAS	(5) QTY INC IN UNIT	(6) 30 DAY DS MAINTENANCE ALLOWANCE			(7) 30 DAY GS MAINTENANCE ALLOWANCE			(8) 1 YR ALW PER 100 EQUIP CNTGCTY	(9) DEPOT MAINT ALW PER 100 EQUIP	(10) ILLUSTRATION	
						(a)	(b)	(c)	(a)	(b)	(c)			(a)	(b)
						1-20	21-50	51-100	1-20	21-50	51-100			FIG NO.	ITEM NO. OR REFERENCE DESIGNATION
X1-D		RESISTOR, FIXED, COMPOSITION: RCR07G472KS; (81349)		EA	1									3-18	A8A1E2R20
X1-D		RESISTOR, FIXED, COMPOSITION: RCR07G103KS; (81349)		EA	1									3-18	A8A1E2R19
X1-D		RESISTOR, FIXED, COMPOSITION: RCR07G223KS; (81349)		EA	2									3-18	A8A1E2R18
X1-D		RESISTOR, FIXED, COMPOSITION: RCR07G223KS; (81349)		EA	REF									3-18	A8A1E2R26
X1-D		RESISTOR, FIXED, COMPOSITION: RCR07G104KS; (81349)		EA	4									3-18	A8A1E2R4
X1-D		RESISTOR, FIXED, COMPOSITION: RCR07G101KS; (81349)		EA	REF									3-18	A8A1E2R7
X1-D		RESISTOR, FIXED, COMPOSITION: RCR07G104KS; (81349)		EA	REF									3-18	A8A1E2R13
X1-D		RESISTOR, FIXED, COMPOSITION: RCR07G104KS; (81349)		EA	REF									3-18	A8A1E2R28
X1-D		RESISTOR, FIXED, COMPOSITION: RC520G470KS; (81349)		EA	1									3-18	A8A1E2R2
X1-D		RESISTOR, FIXED, FILM: RN60D46RF; (81349)		EA	1									3-18	A8A1E2R32
X1-D		RESISTOR, FIXED, FILM: RN60D1001F; (81349)		EA	5									3-18	A8A1E2R9
X1-D		RESISTOR, FIXED, FILM: RN60D1001F; (81349)		EA	REF									3-18	A8A1E2R10
X1-D		RESISTOR, FIXED, FILM: RN60D1001F; (81349)		EA	REF									3-18	A8A1E2R14
X1-D		RESISTOR, FIXED, FILM: RN60D1001F; (81349)		EA	REF									3-18	A8A1E2R24
X1-D		RESISTOR, FIXED, FILM: RN60D1001F; (81349)		EA	REF									3-18	A8A1E2R23
X1-D		RESISTOR, FIXED, FILM: RN60D1471F; (81349)		EA	1									3-18	A8A1E2R22
X1-D		RESISTOR, FIXED, FILM: RJ60D1961F; (81349)		EA	3									3-18	A8A1E2R17
X1-D		RESISTOR, FIXED, FILM: RJ60D1961F; (81349)		EA	REF									3-18	A8A1E2R25
X1-D		RESISTOR, FIXED, FILM: RN60D1961F; (81349)		EA	REF									3-18	A8A1E2R31
X1-D		RESISTOR, FIXED, FILM: RN60D2151F; (81349)		EA	1									3-18	A8A1E2R11
X1-D		RESISTOR, FIXED, FILM: RN60D2611F; (813;9)		EA	2									3-18	A8A1E2R6
X1-D		RESISTOR, FIXED, FILM: RN60D2611F; (81349)		EA	REF									3-18	A8A1E2R30
X1-D		RESISTOR, FIXED, FILM: RN60D3481F; (81349)		EA	1									3-18	A8A1E2R15
X1-D		RESISTOR, FIXED, FILM: RN60D5111F; (81349)		EA	1									3-18	A8A1E2R16
X1-D		RESISTOR, FIXED, FILM: RN60D6191F; (81349)		EA	1									3-18	A8A1E2R29

REPAIR PARTS FOR DIRECT SUPPORT, GENERAL SUPPORT, AND DEPOT MAINTENANCE (Continued)															
(1) SMR CODE	(2) FEDERAL STOCK NUMBER	(3) DESCRIPTION Reference Number & Mfr. Code Usable on Code		(4) UNIT OF MEAS	(5) QTY INC IN UNIT	(6) 30 DAY DS MAINTENANCE ALLOWANCE			(7) 30 DAY GS MAINTENANCE ALLOWANCE			(8) 1 YR ALW PER 100 EQUIP CNTGCTY	(9) DEPOT MAINT ALW PER 100 EQUIP	(10) ILLUSTRATION	
						(a)	(b)	(c)	(a)	(b)	(c)			(a)	(b)
						1-20	21-50	51-100	1-20	21-50	51-100			FIG NO.	ITEM NO. OR REFERENCE DESIGNATION
X1-D		RESISTOR, FIXED, FILM: RN60D1002F; (81349)	EA	4										3-18	A8A1E2R5
X1-D		RESISTOR, FIXED, FILM: RN60D1002F, (81349)	EA	REF										3-18	A8A1E2R8
X1-D		RESISTOR, FIXED, FILM: RN60D1002F, (81349)	EA	REF										3-18	A8A1E2R12
X1-D		RESISTOR, FIXED, FILM: RN60D1002F; (81349)	EA	REF										3-18	A8A1E2R21
X1-D		RESISTOR, FIXED, FILM: RN65D1001F; (81349)	EA	1										3-18	A8A1E2R33
X1-D		RESISTOR, VARIABLE, WIRE WOUND: 224P1-502, (80294)	EA	1										3-18	A8A1E2R27
X1-D		SEMICONDUCTOR DEVICE, DIODE: 1N816; (07688)	EA	6										3-18	A8A1E2CR1
X1-D		SEMICONDUCTOR DEVICE, DIODE: 1N816, (07688)	EA	REF										3-18	A8A1E2CR2
X1-D		SEMICONDUCTOR DEVICE, DIODE: 1N816; (07688)	EA	REF										3-18	A8A1E2CR3
X1-D		SEMICONDUCTOR DEVICE, DIODE: 1N816, (07688)	EA	REF										3-18	A8A1E2CR4
X1-D		SEMICONDUCTOR DEVICE, DIODE: 1N816, (07688)	EA	REF										3-18	A8A1E2CR5
X1-D		SEMICONDUCTOR DEVICE, DIODE: 1N816, (07688)	EA	REF										3-18	A8A1E2CR6
X1-D		SEMICONDUCTOR DEVICE, SET: Q123, (03887)	EA	1										3-18	A8A1E2CR17
X1-D		TRANSFORMER, AUDIO FREQUENCY: DR230, (80223)	EA	1										3-18	A8A1E2T1
X1-D		TRANSISTOR: 2N1038, (07688)	EA	1										3-18	A8A1E2Q4
X1-D		TRANSISTOR: 2N404, (07688)	EA	1										3-18	A8A1E2Q1
X1-D		TRANSISTOR: JAN2N526, (81350)	EA	2										3-18	A8A1E2Q2
X1-D		TRANSISTOR: JAN2N526, (81350)	EA	REF										3-18	A8A1E2Q3
P-H-T	5820-088-2514	AMPLIFIER SUBASSEMBLY-RECEIVER 549-5655-094, (13499)	EA	1				*	*	*	*	*		3-6	A3A1E3
2-D		SCREW, MACHINE: MS51959-3, (96906)	EA	4							REF	REF			A8A1E3H4
X1-D		BOARD, PRINTED CIRCUIT: 549-5657-004, (13499)	EA	1										3-19	A8A1E3E1
X1-D		CAPACITOR, FIXED, ELECTROLYTIC: CL26BJ2RSTN3, (81349)	EA	1										3-19	A8A1E3C29
X1-D		CAPACITOR, FIXED, ELECTROLYTIC: 150D156XO020B2, (56289)	EA	3										3-19	A8A1E3C30
X1-D		CAPACITOR, FIXED, ELECTROLYTIC: 150D156X0020B2, (56289)	EA	REF										3-19	A8A1E3C31
X1-D		CAPACITOR, FIXED, ELECTROLYTIC: 150D156C0020B2, (56289)	EA	REF										3-19	A8A1E3C42

SECTION II

TM 11-5820-509-35

REPAIR PARTS FOR DIRECT SUPPORT, GENERAL SUPPORT, AND DEPOT MAINTENANCE (CONTINUED)															
(1) SMR CODE	(2) FEDERAL STOCK NUMBER	(3) DESCRIPTION Reference Number & Mfr. Code Usable on Code		(4) UNIT OF MEAS	(5) QTY INC IN UNIT	(6) 30 DAY DS MAINTENANCE ALLOWANCE			(7) 30 DAY GS MAINTENANCE ALLOWANCE			(8) 1 YR ALW PER 100 EQUIP CNTGCTY	(9) DEPOT MAINT ALW PER 100 EQUIP	(10) ILLUSTRATION	
						(a)	(b)	(c)	(a)	(b)	(c)			(a) FIG NO.	(b) ITEM NO. OR REFERENCE DESIGNATION
						1-20	21-50	51-100	1-20	21-50	51-100				
X1-D		CAPACITOR, FIXED, ELECTROLYTIC: 150D476X0006B2; (56289)		EA	1									3-19	A8A1E3C35
X1-D		CAPACITOR, FIXED, ELECTROLYTIC: 150D107X0020S2; (56289)		EA	1									3-19	A8A1E3C40
X1-D		CAPACITOR, FIXED, ELECTROLYTIC: 150D336X0020R2; (56289)		EA	2									3-19	A8A1E3C32
X1-D		CAPACITOR, FIXED, ELECTROLYTIC: 150D336X0020R2; (56289)		EA	REF									3-19	A8A1E3C36
X1-D		CAPACITOR, FIXED, ELECTROLYTIC: 150D476X0020R2; (56289)		EA	1									3-19	A8A1E3C33
X1-D		CAPACITOR, FIXED, ELECTROLYTIC: 150D105X9035A2; (56289)		EA	2									3-19	A8A1E3C28
X1-D		CAPACITOR, FIXED, ELICTROLYTIC: 150D105X9035A2; (56289)		EA	REF									3-19	A8A1E3C34
X1-D		CAPACITOR, FIXED, ELECTROLYTIC: 150D1697; (56289)		EA	3									3-19	A8A1E3C37
X1-D		CAPACITOR, FIXED, ELECTROLYTIC: 150D1697; (56289)		EA	REF									3-19	A8A1E3C38
X1-D		CAPACITOR, FIXED,]LECTROLYTIC: 150D1697; (56289)		EA	REF									3-19	A8A1E3C41
X1-D		INSULATOR TRANSISTOR: T1566; (98291)		EA	3										A8A1E3E2
X1-D		INSULATOR, TRASISTOR: T1566; (98291)		EA	REF										A8A1E3E3
X1-D		INSULATOR, TRAUSSISTOR: T1566; (98291)		EA	REF										A81E3E4
X1-D		JACK, TIP: 105-73100oo; (74970)		EA	1									3-19	A8A1E3J15
X1-D		JACK, TIP: 105-736-100; (74970)		EA	1									3-19	ABA1E3J13
X1-D		JACK, TIP: 105-740-100; (74970)		EA	1									3-19	A8A1E3J16
X1-D		JACK, TIP: 105-737-100; (74970)		EA	1									3-19	ASA1E3J11
X1-D		REACTOR: DR905; (80223)		EA	1									3-19	A8A1E3L3
X1-D		RESISTOR, FIXED, COMPOSITION: RCR07G122KS; (81349)		EA	1									3-19	A8A1E3R72
X1-D		RESISTOR, FIXED, CDMPOSITION: RCR07G152KS; (81349)		EA	1									3-19	A8A1E3R45
X1-D		RESISTOR, FIXED, CODPOSITION: RCR07G272KS; (81349)		EA	1									3-19	A8A1E3R63
X1-D		RESISTOR, FIXED, CODPOSITION: RCR07G332K; (81349)		EA	1									3-19	A8A1E3R51
X1-D		RESISTOR, FIXED, COWOSITION: RCR07G103KS; (81349)		EA	4									3-19	A8A1E3R47
X1-D		RBSISTOR, FIXED, COMPOSITION: RCR07G103KS; (81349)		EA	REF									3-19	A8A1E3R53
X1-D		RESISTOR, FIXED, COOSITION: RCR07G103KS; (81349)		EA	REF									3-19	A8A1E3R64

REPAIR PARTS FOR DIRECT SUPPORT, GENERAL SUPPORT, AND DEPOT MAINTENANCE (CONTINUED)															
(1) SMR CODE	(2) FEDERAL STOCK NUMBER	(3) DESCRIPTION Reference Number & Mfr. Code Usable on Code		(4) UNIT OF MEAS	(5) QTY INC IN UNIT	(6) 30 DAY DS MAINTENANCE ALLOWANCE			(7) 30 DAY GS MAINTENANCE ALLOWANCE			(8) 1 YR ALW PER 100 EQUIP CNTGCTY	(9) DEPOT MAINT ALW PER 100 EQUIP	(10) ILLUSTRATION	
						(a) 1-20	(b) 21-50	(c) 51-100	(a) 1-20	(b) 21-50	(c) 51-100			(a) FIG NO.	(b) ITEM NO. OR REFERENCE DESIGNATION
X1-D		RESISTOR, FIXED, COMPOSITION: RCR07G1T3KS; (81349)			EA	REF								3-19	A8A1E3R68
X1-D		RESISTOR, FIXED, COMPOSITION: RCR07G123KS; (81349)			EA	2								3-19	A8A1E3R58
X1-D		RESISTOR, FIXED, COMPOSITION: RCR07G123KS; (81349)			EA	REF								3-19	A8A1E3R78
X1-D		RESISTOR, FIXED, COMPOSITIOW: RCR07G183KS; (81349)			EA	1								3-19	A8A1E3R55
X1-D		RESISTOR, FIXED, COMPOSITION: RCR07G223KS; (81349)			EA	2								3-19	A8A1E3R48
X1-D		RESISTOR, FIXED, COMPOSITION: RCROTG223KS; (81349)			EA	REF								3-19	A8A1E3R74
X1-D		RESISTOR, FIXED, COMPOSITION: RCR07C273KS; (81349)			EA	2								3-19	A8A1E3R59
X1-D		RESISTOR, FIXED, COMPOSITION: RCR07G273KS; (81349)			EA	REF								3-15	A8A1E3R73
X1-D		RESISTOR, FIXED, COMPOSITION: RCR07G104KS; (81349)			EA	3								3-15	A8A1E3R49
X1-D		RESISTOR, FIXED, COMPOSITION: RCR07G104KS; (81349)			EA	REF								3-19	A8A1E3R76
X1-D		RESISTOR, FIXED, COMPOSITION: RCR07G104KS; (81349)			EA	REF								3-19	A8A1E3R77
X1-D		RESISTOR, FIXED, COMPOSITION: RCR07G184KS; (81349)			EA	1								3-19	A8A1E3R50
X1-D		RESISTOR, FIXED, COMPOSITION: RCR07G474KS; (81349)			EA	1								3-19	A8A1E3R75
X1-D		RESISTOR, FIXED, FILM: RN60D51R1F; (81349)			EA	1								3-19	A8A1E3R65
X1-D		RESISTOR, FIXED, FILM: RN60D4221F; (81349)			EA	1								3-19	A8A1E3R66
X1-D		RESISTOR, FIXED, FILM: RN60D5111F; (81349)			EA	2								3-19	A8A1E3R61
X1-D		RESISTOR, FIXED, FILM: RN60D5111Y; (81349)			EA	REF								3-19	A8A1E3R62
X1-D		RESISTOR, FIXED, FILM: RN60D1102F; (81349)			EA	1								3-19	A8A1E3R56
X1-D		RESISTOR, FIXED, FILM: RN60D1102F; (81349)			EA	1								3-19	A8A1E3R57
X1-D		RESISTOR, FIXED, FILM: RN60D1622F; (81349)			EA	1								3-19	A8A1E3R60
X1-D		RESISTOR, THERMAL: 763F28; (10646)			EA	1								3-15	A8A1E3R67
X1-D		RESISTOR, VARIABLE, WIREWOUND: 224P1-102; (80294)			EA	1								3-15	A8A1E3R54
X1-D		RESISTOR, VARIABLE, WIREOIRD: 224P1-503; (80294)			EA	2								3-19	A8A1E3R46
X1-D		RESISTOR, VARIABLE, WIREWOUND 224P1-503; (80294)			EA	REF								3-15	A8A1E3R52
X1-D		SEMICONDUCTOR DEVICE, DIODE: 11457; (07688)			EA	3								3-15	A8A1E3CR11

REPAIR PARTS FOR DIRECT SUPPORT, GENERAL SUPPORT, AND DEPOT MAINTENANCE (CONTINUED)															
(1) SMR CODE	(2) FEDERAL STOCK NUMBER	(3) DESCRIPTION Reference Number & Mfr. Code Usable on Code		(4) UNIT OF MEAS	(5) QTY INC IN UNIT	(6) 30 DAY DS MAINTENANCE ALLOWANCE			(7) 30 DAY GS MAINTENANCE ALLOWANCE			(8) 1 YR ALW PER 100 EQUIP CNTGCTY	(9) DEPOT MAINT ALW PER 100 EQUIP	(10) ILLUSTRATION	
						(a)	(b)	(c)	(a)	(b)	(c)			(a)	(b)
						1-20	21-50	51-100	1-20	21-50	51-100			FIG NO.	ITEM NO. OR REFERENCE DESIGNATION
X1-D		SEMICONDUCTOR DEVICE, DIODE: LN457, (07688)		EA	REF									3-19	A8A1E3CR12
X1-D		SEMICONDUCTOR DEVICE, DIODE: 1N457; (07688)		EA	REF									3-19	A8A1E3CR13
X1-D		SEMICONDUCTOR DEVICE, DIODE: TRANSISTOR: JAN2N526, (81350)		EA	1									3-19	A8A1E3CR10
X1-D		TRANSISTOR: JAN2N526, (81350)		EA	3									3-19	A8A1E3Q8
X1-D		TRANSISTOR: JAN2N526, (81350)		EA	REF									3-19	A8A1E3Q9
X1-D		TRANSISTOR: JAN2N526; (81350)		EA	REF									3-19	A8A1E3Q10
P--D		CAPACITOR, FIXED, CERAMIC: 33C58; (01939)		EA	1						*	*		3-16	A8A1C43
P--D	5910-834-8493	CAPACITOR, FIXED, ELECTROLYTIC: 150D476X003582, (56289)		EA	1						*	*		3-16	A8A1C44
P--D		CHASSIS, ELECTRICAL EQUIPMENT: 549-5659-005, (13499)		EA	1										A8A1MP1
P--D	5935-808-7502	CONNECTOR, RECEPTACLE: DBM25P, (71i68)		EA	1						*	*		3-16	A8A1P1
P--D	5310-622-1724	NUT, SELF-LOCKING, HEXAGON: 68-1660-26, (72962)		EA	2						REF	REF			A8A1P1H1
P--D	5310-622-1724	NUT, SELF-LOCKING, HEXAGON: 68-1660-26; (72962)		EA	REF						REF	REF			A8A1P1H2
P--D	5305-770-2533	SCREW, MACHINE: MS51959-13; (77250)		EA	2						REF	REF			A8A1P1H3
P--D	5305-770-2533	SCREW, MACHINE MS51959-13; (77250)		EA	REF						REF	REF			A8A1P1H4
P--D		WASHER, FLAT: 310-0044-000; (79807)		EA	2						REF	REF			A8A1P1H5
P--D		WASHER, FLAT: 310-0044-000; (79807)		EA	REF						REF	REF			A8A1P1H6
P--H-T	5820-975-5412	CONTROL OSCILLATOR GROUP: 549-5654-004; (13499)		EA	1				*	*	*	*	*	3-6	A8A1E1
P--D	5305-727-8833	SCREW, MACHINE: MS51959-3, (96906)		EA	6						REF	REF			A8A1E1H6
X1-D		BOARD, PRINTED CIRCUIT 549-5650-003, (13499)		EA	1									3-17	A8A1E1E1
X1-D		CAPACITOR, FIXED, CERAMIC: 6S8083, (56289)		EA	1									3-17	A8A1E1C18
X1-D		CAPACITOR, FIXED, ELECTROLYTIC: 150D476X0035S2, (56289)		EA	2									3-17	A8A1E1C1
X1-D		CAPACITOR, FIXED, ELECTROLYTIC: 150D476X0035S2, (56289)		EA	REF									3-17	A8A1E1C22
X1-D		CAPACITOR, FIXED, ELECTROLYTIC: 150D394X9035A2, (56289)		EA	1									3-17	A8A1E1C26
X1-D		CAPACITOR, FIXED, ELECTROLYTIC: 150D564X9035A2, (56289)		EA	1									3-17	A8A1E1C26
X1-D		CAPACITOR, FIXED, ELECTROLYTIC: 150D684X0035A2, (56289)		EA	1									3-17	A8A1E1C26
*SELECT PER OPERATIONAL REQUIREMENT.															

REPAIR PARTS FOR DIRECT SUPPORT, GENERAL SUPPORT, AND DEPOT MAINTENANCE (CONTINUED)															
(1) SMR CODE	(2) FEDERAL STOCK NUMBER	(3) DESCRIPTION Reference Number & Mfr. Code Usable on Code		(4) UNIT OF MEAS	(5) QTY INC IN UNIT	(6) 30 DAY DS MAINTENANCE ALLOWANCE			(7) 30 DAY GS MAINTENANCE ALLOWANCE			(8) 1 YR ALW PER 100 EQUIP CNTGCTY	(9) DEPOT MAINT ALW PER 100 EQUIP	(10) ILLUSTRATION	
						(a)	(b)	(c)	(a)	(b)	(c)			(a) FIG NO.	(b) ITEM NO. OR REFERENCE DESIGNATION
						1-20	21-50	51-100	1-20	21-50	51-100				
X1-D		CAPACITOR, FIXED, ELECTROLYTIC: 150D105X9035A2, (56289)		EA	1									3-17	ARAE1C17
X1-D		CAPACITOR, FIXED, ELECTROLYTIC: 150D336X9010B2, (56289)		EA	2									3-17	A8A1E1C23
X1-D		CAPACITOR, FIXED, ELECTROLYTIC: 150D336X9010B2, (56289)		EA	REF									3-17	A8A1E1C24
X1-D		CAPACITOR, FIXED, ELECTROLYTIC: 150D474X9035A2, (56289)		EA	1									3-17	A8A1E1C26 *
X1-D		CAPACITOR, FIXED, ELECTROLYTIC: 150D334X9035A2, (56289)		EA	1									3-17	A8A1E1C26 *
X1-D		CAPACITOR, FIXED, ELECTROLYTIC: 150D1697; (56289)		EA	2									3-17	A8A1E1C21
X1-D		CAPACITOR, FIXED, ELECTROLYTIC: 150D1697; (56289)		EA	REF									3-17	A8A1E1C25
X1-D		CAPACITOR, FIXED, MICA: CM06FD302F03, (81349)		EA	1									3-17	A8A1E1C19
X1-D		CAPACITOR, FIXED, MICA: DM30F153F03, (72136)		EA	1									3-17	A8A1E1C20
X1-D		COIL, RADIO FREQUMUEICY: MP206-31B, (95105)		EA	1									3-17	A8A1E1L1
X1-D		SCREW, MACHIN: P343-0329-000; (77250)		EA	1										A8A1E1L1H1
X1-D		JACK, TIP: 105-731-100, (74970)		EA	1									3-17	A8A1E1J9
X1-D		JACK, TIP: 105-732-100; (74970)		EA	1									3-17	A8A1E1J12
X1-D		JACK, TIP: 105-733-100, (74970)		EA	1									3-17	A8A1E1J10
X1-D		JACK, TIP: 105-738-100, (74970)		EA	1									3-17	A8A1E1J11
X1-D		JACK, TIP: 105-743-100, (74970)		EA	1									3-17	A8A1E1J8
X1-D		REACTOR: 678-0084-000; (13499)		EA	1									3-17	A8A1E1L2
X1-D		SCREW, MACHINE: P343-0329-000; (77250)		EA	1										A8A1E1L2H1
X1-D		RELAY, ARMATURE: 3SAK1005, (01526)		EA	1									3-17	A8A1E1K1
X1-D		RESISTOR, FIXED, COMPOSITION: RCR07G104KS, (81349)		EA	5									3-17	A8A1E1R34
X1-D		RESISTOR, FIXED, COMPOSITION: RCR07D104KS, (81349)		EA	REF									3-17	A8A1E1R38
X1-D		RESISTOR, FIXED, COMPOSITION: RCR07G104KS, (81349)		EA	REF									3-17	A8A1E1R39
X1-D		RESISTOR, FIXED, COMPOSITION: RCR07G104KS, (81349)		EA	REF									3-17	A81E1R41
X1-D		RESISTOR, FIXED, COMPOSITION: RCR07GIC0KS, (81349)		EA	REF									3-17	A8A1E1R44
X1-D		RESISTOR, FIXED, COMPOSITION: RC42GF681K; (81349)		EA	1									3-17	A8A1E1R3

SECTION II

TM 11-5820-509-35

REPAIR PARTS FOR DIRECT SUPPORT, GENERAL SUPPORT, AND DEPOT MAINTENANCE (CONTINUED)															
(1) SMR CODE	(2) FEDERAL STOCK NUMBER	(3) DESCRIPTION Reference Number & Mfr. Code Usable on Code		(4) UNIT OF MEAS	(5) QTY INC IN UNIT	(6) 30 DAY DS MAINTENANCE ALLOWANCE			(7) 30 DAY GS MAINTENANCE ALLOWANCE			(8) 1 YR ALW PER 100 EQUIP CNTGCTY	(9) DEPOT MAINT ALW PER 100 EQUIP	(10) ILLUSTRATION	
						(a)	(b)	(c)	(a)	(b)	(c)			(a) FIG NO.	(b) ITEM NO. OR REFERENCE DESIGNATION
						1-20	21-50	51-100	1-20	21-50	51-100				
X1-D		RESISTOR, FIXED, FILM: RH60D215_F, (81349)		EA	1									3-17	A8A1E1R36
X1-D		RESISTOR, FIXED, FILM: RN60D5111F, (81349)		EA	1									3-17	A8A1E1R43
X1-D		RESISTOR, FIXED, FILM: RN60D1782F; (81349)		EA	1									3-17	A8A1E1R37
X1-D		RESISTOR, FIXED, FILM: RN60D2372F, (81349)		EA	1									3-17	A8A1E1R35
X1-D		RESISTOR, THERMAL: 763F28, (10646)		EA	2									3-17	A8A1E1R42
X1-D		RESISTOR, THERMAL: 763F28, (10646)		EA	REF									3-17	ABA1E1R85
X1-D		RESISTOR, THERMAL: TITM1 4-3900-5PC; (96214)		EA	1									3-17	A8A1E1R83
X1-D		RESISTOR, VARIABLE, WIREWOUND: 224P1-502, (80294)		EA	1									3-17	A8A1E1R40
X1-D		SEMICONDUCTOR DEVICE, DIODE: 1N457, (07688)		EA	2									3-17	A8AE1CR9
X1-D		SEMICONDUCTOR DEYICE, DIODE: 1N457, (07688)		EA	REF									3-17	AA1Le1CR18
X1-D		SEMICONDUCTOR DEVICE, DIODE: 1N816, (07688)		EA	2									3-17	A8A1E1CR7
X1-D		SEMICONDUCTOR DEVICE, DIODE: 1N816; (07688)		EA	REF									3-17	A8A1E1CR8
X1-D		TRANSISTOR: 2N697, (07688)		EA	1									3-17	A8A1E1Q7
X1-D		TRANSISTOR: JAN2N333, (81350)		EA	1									3-17	A8A1E1Q6
X1-D		TRANSISTOR: JAN2526, (81350)		EA	1									3-17	A8A1E1Q5
M--D		COVER, AMPLIFIER-AUDIO FREQUENCY: 549-5703-005; (13499)		EA	1										A8A1MP2
P--D	5305-054-5648	SCREW, MACHINE: MS51957-14, (96906)		EA	2							REF	REF		A8A1MP2H1
P--D	5305-054-5648	SCREW, MACHINE: MS51957-14, (96906)		EA	REF							REF	REF		A8A1MP2H2
P--D	5310-136-6133	WASHER, FLAT: 310-6340-000, (79807)		EA	2							*	*		A8A1MP2H3
P--D	5310-136-6133	WASHER, FLAT: 310-63 0-000, (79807)		EA	REF							REF	REF		A8A1MP2H4
M--D		HARNES, WIRING, BRANCHED: 549-5641-000, (13499)		EA	1										A8A1W1
P--D	5905-279-3521	RESISTOR, FIXED, COMPOSITION: RCR20G150KS, (81349)		EA	1							*	*	3-16	A8A1R81
P--D	5905-279-1745	RESISTOR, FIXED, COMPOSITION: RCR32G150KS, (81349)		EA	1							*	*	3-16	A8A1R84
P--D		RESISTOR, FIXED, COMPOSITION: RCR32G152KS, (81349)		EA	1							*	*	3-16	A8A1R79
P--D	5905-252-1953	RESISTOR, FIXED, COMPOSITION: RC42CF100K, (81349)		EA	1							*	*	3-16	A8A1R82

REPAIR PARTS FOR DIRECT SUPPORT, GENERAL SUPPORT, AND DEPOT MAINTENANCE (CONTINUED)															
(1) SMR CODE	(2) FEDERAL STOCK NUMBER	(3) DESCRIPTION Reference Number & Mfr. Code Usable on Code		(4) UNIT OF MEAS	(5) QTY INC IN UNIT	(6) 30 DAY DS MAINTENANCE ALLOWANCE			(7) 30 DAY GS MAINTENANCE ALLOWANCE			(8) 1 YR ALW PER 100 EQUIP CNTGCTY	(9) DEPOT MAINT ALW PER 100 EQUIP	(10) ILLUSTRATION	
						(a) 1-20	(b) 21-50	(c) 51-100	(a) 1-20	(b) 21-50	(c) 51-100			(a) FIG NO.	(b) ITEM NO. OR REFERENCE DESIGNATION
P--D	5905-827-0724	RESISTOR, THEIMAL: 763F2, (10646)		EA	1							*	*	3-16	A8A1R80
P--D		SEMICONDUCTOR SET: 2N158AMATCHEDPR: (C7688)		EA	1							*	*	3-16	A8A1Q11
M--D		INSULATOR, BUSHING: 549-5642-002; (13499)		EA	2										ABA1Q11H1
P--D	5305-705-9528	SCREW, EXTERNALLY RELIEVED BODY: 542-1348-002, (13499)		EA								2	**		A8A1Q11H2
P--D	5970-143-3596	WASHER: 543-5561-003; (13499)		EA	2							*	*		A8A1Q11H3
P-D	5340-975-7637	TERMINAL, GROUND: 549-5709-002, (13499)		EA	1							REF	REF		A8A1E4
P--D	5305-616-2568	SCREW, MAKGINE: P343-0285-000; (77250)		EA	1							REF	REF		A8AE14H1
P--D		WASHER, LOCK: MS35338-135; (96906)		EA	1							REF	REF		A8A1E4H2
P--D		TERMINAL, LUG: 040-2HT, (77147)		EA	1							REF	REF		A8A1E5
P--D	5310-934-9740	NUT, PLAIN, HEXAGON: MS35649-225, (96906)		EA	1							REF	REF		A8A1E5H1
P--D	5305-576-6002	SCREW, MACHINE: P343-0298-000; (77250)		EA	1							REF	REF		A8A1ER5H2
P--D	5310-981-2255	WASHER, SPRING TENSION: 310-0074-00, (79807)		EA	1							REF	REF		A8A1E5H3
P--D		TERMINAL, LUG: 4007-4HT, (77147)		EA	1							REF	REF		A8A1E6
P--D	5950-812-0292	TRANSFORMER, AUDIO FREQUENCY: A12425, (70674)		EA	1							*	*	3-16	A8A1T2
P--D	5305-770-2533	SCREW, MACHINE: MS51959-13, (96906)		EA	4							REF	REF		A8A1T2H1
P--D	5305-770-2533	SCREW, MACHINE: MS51959-13, (96906)		EA								REF	REF		A8A1T2H2
P--D	5305-770-2533	SCREW, MACHINE: MS51959-13, (96906)		EA								REF	REF		A8A1T2H3
P--D	5305-770-2533	SCREW, MACHINE: MS51959-13, (96906)		EA								REF	REF		A8A1T2H4
P--D	5950-951-1391	TRANSFORMER, AUDIO FRQUENCY: A12426, (706794)		EA	1							*	*	3-16	A8A1T3
P--D	5305-770-2533	SCREW, MACNINE: MS51959-13, (96906)		EA	4							REF	REF		A8A1T3H1
P--D	5305-770-2533	SCREW, MACHINE: MS51959-13, (96906)		EA								REF	REF		A8A1T3H2
P--D	5305-770-2533	SCREW, MACHINE: MS51959-13, (96906)		EA								REF	REF		A8A1T3H3
P--D	5305-770-2533	SCREW, MACHINE: NS51959-13, (96906)		EA								REF	REF		A8A1T3H4
P--D	5950-951-7181	TRANSFORMER, AUDIO FREQUENCY: A12808, (70674)		EA	1							*	*	3-16	A8A1T5
P--D	5305-770-2533	SCREW, MACHINE: MS51959-13; (96906)		EA	4							REF	REF		A8A1T5H1

REPAIR PARTS FOR DIRECT SUPPORT, GENERAL SUPPORT, AND DEPOT MAINTENANCE (CONTINUED)															
(1) SMR CODE	(2) FEDERAL STOCK NUMBER	(3) DESCRIPTION Reference Number & Mfr. Code Usable on Code		(4) UNIT OF MEAS	(5) QTY INC IN UNIT	(6) 30 DAY DS MAINTENANCE ALLOWANCE			(7) 30 DAY GS MAINTENANCE ALLOWANCE			(8) 1 YR ALW PER 100 EQUIP CNTGCTY	(9) DEPOT MAINT ALW PER 100 EQUIP	(10) ILLUSTRATION	
						(a)	(b)	(c)	(a)	(b)	(c)			(a) FIG NO.	(b) ITEM NO. OR REFERENCE DESIGNATION
						1-20	21-50	51-100	1-20	21-50	51-100				
P--D	5305-770-2533	SCREW, MACHINE: NS51959-13; (96906)		EA	REF							REF	REF		A8A1T5H2
P--D	5305-770-2533	SCREW, MACHINE: S51959-13; (96906)		EA	REF							REF	REF		A8A1T5H3
P--D	5305-770-2533	SCREW, MACHINE: MS51959-13; (96906)		EA	REF							REF	REF		A8A1T5H4
P--D	5820-087-2304	POWER SUPPLY: PP351SPRC7T; (80058)		EA	1				*	*	*	*	*	3-4	A8A5
P--D	5999-965-5571	ADAPTER, CABLE: YE1620F32; (09922)		EA	5							*	*		A8A5E12
P--D		ADAPTER, CABLE: YE1620F32; (09922)		EA	REF							REF	REF		A8A5E13
P--D		ADAPTER, CABLE: YE1620F32; (09922)		EA	REF							REF	REF		A8A5E14
P--D		ADAPTER, CABLE: YE1620F32; (09922)		EA	REF							REF	REF		A8A5E15
P--D		ADAPTER, CABLE: YE1620F32; (09922)		EA	REF							REF	REF		A8A5E16
P--D	5910-780-8675	CAPACITOR, FIXED, ELECTROLYTIC: 600D476G050DE5; (56289)		EA	4							*	*	3-50	A8A5C25
P--D		CAPACITOR, FIXED, ELECTROLYTIC: 600D476G050DE5; (56289)		EA	REF							REF	REF	3-45	A8A5C27
P--D		CAPACITOR, FIXED, ELECTROLYTIC: 600D476G050DE5; (56289)		EA	REF							REF	REF	3-45	ABA5C28
P--D		CAPACITOR, FIXED, ELECTROLYTIC: 600D476G050DE5; (56289)		EA	REF							REF	REF	3-45	A8A5C29
P--D	5910-968-5427	CAPACITOR, FIXED, ELECTROLYTIC: 600D107G050DJ5; (56289)		EA	1							*	*	3-45	A8A5C26
P--D	5910-421-2325	CAPACITOR, FIXED, ELECTROLYTIC: 600D136F20050DG5; (56289)		EA	1							*	*	3-50	A8A5C1
P--D	5910-954-3038	CAPACITOR, FIXED, ELECTROLYTIC: D42974; (56289)		EA	2							*	*	3-11	A8A5C19A
P--D	5910-954-3038	CAPACITOR, FIXED, ELECTROLYTIC: D42974; (56289)		EA	REF							REF	REF	3-11	A8ASC19B
P--D	5910-949-1438	CAPACITOR, FIXED, PAPER: 930-0524-000; (13499)		EA	1							*	*	3-45	A8A5C16
M--D		CHASSIS, ELECTRICAL, EQUIPMENT: 549-5835-005; (13499)		EA	1										A8A5MP1
M--D		CHASSIS, ELECTRICAL, EQUIPMENT: 549-6406-004; (13499)		EA	1									3-11	A8A5A1
P--D		SCREW, MACHINE: P330-2290-000; (77250)		EA	1							*	*		A8A5A1H1
P--D	5305-05-6651	SCREW, MACHINE: MS51957-27; (96906)		EA	2							REF	REF		A8A5A1H2
P--D	5935-766-646	JACK, TIP: 72-153BLK; (12615)		EA	1							*	*	3-11	A8A5A1J10
P--D		JACK, TIP: 72-153BRN; (12615)		EA	2							*	*	3-11	A8A5A1J1
P--D		JACK, TIP: 72-153BRN; (12615)		EA	REF							REF	REF	3-11	A8A5A1J11

SECTION II

TM 11-5820-509-35

REPAIR PARTS FOR DIRECT SUPPORT, GENERAL SUPPORT, AND DEPOT MAINTENANCE (CONTINUED)															
(1) SMR CODE	(2) FEDERAL STOCK NUMBER	(3) DESCRIPTION Reference Number & Mfr. Code Usable on Code		(4) UNIT OF MEAS	(5) QTY INC IN UNIT	(6) 30 DAY DS MAINTENANCE ALLOWANCE			(7) 30 DAY GS MAINTENANCE ALLOWANCE			(8) 1 YR ALW PER 100 EQUIP CNTGCTY	(9) DEPOT MAINT ALW PER 100 EQUIP	(10) ILLUSTRATION	
						(a)	(b)	(c)	(a)	(b)	(c)			(a) FIG NO.	(b) ITEM NO. OR REFERENCE DESIGNATION
						1-20	21-50	51-100	1-20	21-50	51-100				
P--D	5935-061-1363	JACK, TIP: 72-153RED; (12615)		EA	1							*	*	3-11	A8A5A1J2
P--D	5935-080-9292	JACK, TIP: 72-153ORN; (12615)		EA	1							*	*	3-11	A8A5A1J3
P--D	5935-080-9293	JACK, TIP: 72-153YEL; (12615)		EA	1							*	*	3-11	A8A5A1J4
P--D	5935-988-4769	JACK, TIP: 72-153GRN; (12615)		EA	1							*	*	3-11	A8A5A1J5
P--D	5935-951-4052	JACK, TIP: 72-153BLU; (12615)		EA	1							*	*	3-11	A8A5A1J6
P--D	5935-951-4053	JACK, TIP: 72-153VIO; (12615)		EA	1							*	*	3-11	A8A5A1J7
P--D	5935-960-7324	JACK, TIP: 72-153GRA; (12615)		EA	1							*	*	3-11	A8A5A1J8
P--D	5935-954-4470	JACK, TIP: 72-153WHT; (12615)		EA	1							*	*	3-11	A8A5A1J9
P--D	CLAMP, LOOP:	HP4N; (09922)		EA	1							*	*		A8A5MP2
P--D	5305-05h-6653	SCREW, MACHINE: MS51957-29; (96906)		EA	1							*	*		A8A5MP2H2
P--D	5310-531-9514	WASHER, FLAT: 310-6360-000; (79807)		EA	1							*	*		A8A5MP2H1
P--D		CONNECTOR, RECEPTACLE: DCM27W2P; (71h68)		EA	1							*	*	3-45	A8A5P1
P--D		SCREW, MACHINE: P330-2286-000; (77250)		EA	1							*	*		A8A5P1B1
P--D	5305-054-5637	SCREW, MACHINE: MS51957-3; (96906)		EA	2							*	*		A8A5P1H2
P--D	5305-054-5637	SCREW, MACHINE: MS51957-3; (96906)		EA	REF							REF	REF		A8A5P1H3
P--D	5305-054-5638	SCREW, MACHINE: MS51957-4; (96906)		EA	1							REF	REF		A8A5P1H4
P--D		WASHER, FLAT: 310-6320-00; (79807)		EA	2							REF	REF		A8A5P1H5
P--D		WASHER, FLAT: 310-6320-00; (79807)		EA	REF							REF	REF		A8A5P1H6
M--D		COVER, POWER SUPPLY: 549-5815-003; (13499)		EA	1										A8A5MP3
P--D	5305-685-1490	SCREW, MACHINE: P330-2290-000; (77250)		EA	1							REF	REF		A8A5MP3H1
P--D	5305-764-2964	SCREW, MACHINE: MS51959-4; (96906)		EA	2							REF	REF		A8A5MP3H2
P--D	5305-764-2964	SCREW, MACHINE: MS51959-4; (96906)		EA	REF							REF	REF		A8A5MP3H3
P--D	5310-782-1349	WASHER, FLAT: 310-0045-00; (79807)		EA	2							REF	REF		A8A5MP3H4
P--D	5310-782-1349	WASHER, FLAT: 310-0045-00; (79807)		EA	REF							REF	REF		A8A5MP3H5
M-D		HARNES, WIRING, BRANCHED: 549-5810-000; (13499)		EA	1										A8A5W1

REPAIR PARTS FOR DIRECT SUPPORT, GENERAL SUPPORT, AND DEPOT MAINTENANCE (CONTINUED)															
(1) SMR CODE	(2) FEDERAL STOCK NUMBER	(3) DESCRIPTION Reference Number & Mfr. Code Usable on Code		(4) UNIT OF MEAS	(5) QTY INC IN UNIT	(6) 30 DAY DS MAINTENANCE ALLOWANCE			(7) 30 DAY GS MAINTENANCE ALLOWANCE			(8) 1 YR ALW PER 100 EQUIP CNTGCTY	(9) DEPOT MAINT ALW PER 100 EQUIP	(10) ILLUSTRATION	
						(a) 1-20	(b) 21-50	(c) 51-100	(a) 1-20	(b) 21-50	(c) 51-100			(a) FIG NO.	(b) ITEM NO. OR REFERENCE DESIGNATION
P--D	5935-034-1097	INSERT, CONNECTOR: DM51157, (71468)		EA	2							*	*		A8A5P1A1
P--D	5935-034-1097	INSERT, CONNECTOR: DM51157, (71468)		EA	REF							REF	REF		A8A5P1A2
M--D		PIN, LOCATING: 549-5836-002, (13499)		EA	2										A8A5MP4
P--D	5305-054-6668	SCREW, MACHINE: MS51957-43, (96906)		EA	1							*	*		A8A5MP4H1
P--D	5310-933-8119	WASHER, LOCK, SPLIT: MS35338-137, (96906)		EA	1							*	*		A8A5MP4H2
M--D		PIN, LOCATING: 549-5836-002; (13499)		A	REF										A8A5MP5
P--D	5305-054-6668	SCREW, MACHINE: MS51957-43, (96906)		EA	1							REF	REF		A8A5MP5H1
P--D		WASHER, FLAT: 310-0048-000; (79807)		EA	2							*			A8A5MP5H2
P--D		WASHER, FLAT: 310-0048-000; (79807)		EA	REF							REF	REF		A8A5MP5H3
P--D	5310-933-8119	WASHER, LOCK, SPLIT: MS35338-137, (96906)		EA	1							REF	REF		A8A5MPS5H4
M--D	5325-960-2410	PLASTIC CHANNEL: MS21266-1N, (96906)		EA	2										A8A5MP6
M--D	5340-984-0423	POST, HEXAGON-TAPPED: 549-5811-002, (13499)		EA	2										A8A5MP7
M--D	5340-984-0423	POST, HEXAGON-TAPPED: 549-5811-002, (13499)		EA	REF										A8A5MP8
P--H-T	6130-088-1381	POWER SUPPLY SUBASSEMBLY-1: 549-5831-004; (13499)		EA	1				*	*	*	*	*	3-11	A8A5E1
P--D	5305-054-5647	SCREW, MACHINE: MS51957-13, (96906)		EA	4							REF	REF		A8A5E1H4
X1-D		BOARD, TERMINAL-POWER SUPPLY: 549-5833-004, (13499)		EA	1									3-47	A8A5E1E1
X1-D		CAPACITOR, FIXED, CERAMIC: CK60AW102M, (81349)		EA	2									3-47	A8A5E1C18
X1-D		CAPACITOR, FIXED, CERAMIC: CK60AW102M, (81349)		EA	REF									3-47	A8A5E1C21
X1-D		CAPACITOR, FIXED, CERAMIC: 20C119, (56289)		EA	12									3-47	A8A5E1C3
X1-D		CAPACITOR, FIXED, CERAMIC: 20C119, (56289)		EA	REF									3-47	A8A5E1C4
X1-D		CAPACITOR, FIXED, CERAMIC: 20C119, (56289)		EA	REF									3-47	A8A5E1C5
X1-D		CAPACITOR, FIXED, CERAMIC: 20C119, (56289)		EA	REF									3-47	A8A5E1C6
X1-D		CAPACITOR, FIXED, CERAMIC: 20C119, (56289)		EA	REF									3-47	A8A5E1C7
X1-D		CAPACITOR, FIXED, CERAMIC: 20C119, (56289)		EA	REF									3-47	A8A5E1C8
X1-D		CAPACITOR, FIXED, CERAMIC: 20C119, (56289)		EA	REF									3-47	A8A5E1C9

REPAIR PARTS FOR DIRECT SUPPORT, GENERAL SUPPORT, AND DEPOT MAINTENANCE (CONTINUED)															
(1) SMR CODE	(2) FEDERAL STOCK NUMBER	(3) DESCRIPTION Reference Number & Mfr. Code Usable on Code		(4) UNIT OF MEAS	(5) QTY INC IN UNIT	(6) 30 DAY DS MAINTENANCE ALLOWANCE			(7) 30 DAY GS MAINTENANCE ALLOWANCE			(8) 1 YR ALW PER 100 EQUIP CNTGCTY	(9) DEPOT MAINT ALW PER 100 EQUIP	(10) ILLUSTRATION	
						(a)	(b)	(c)	(a)	(b)	(c)			(a) FIG NO.	(b) ITEM NO. OR REFERENCE DESIGNATION
						1-20	21-50	51-100	1-20	21-50	51-100				
X1-D		CAPACITOR, FIXED, CERAMIC: 20C119; (56289)		EA	REF									3-47	A8A5E1C10
X1-D		CAPACITOR, FIXED, CERAMIC: 20C119; (56289)		EA	REF									3-47	A8A5E1C11
X1-D		CAPACITOR, FIXED, CERAMIC: 20C119; (56289)		EA	REF									3-47	A8A5E1C12
X1-D		CAPACITOR, FIXED, CERAMIC: 20C119; (56289)		EA	REF									3-17	A8A5E1C13
X1-D		CAPACITOR, FIXED, CERAMIC: 20C119; (56289)		EA	REF									3-47	A8A5E1C14
X1-D		CAPACITOR, FIXED, CERAMIC: DD16-103; (71590)		EA	1									3-7T	A8A5E1C15
X1-D		SEMICONDUCTOR DEVICE, DIODE: 1N3641; (07688)		EA	20									3-46	A8A5E1CR6
X1-D		SEMICONDUCTOR DEVICE, DIODE: 1N3641; (07688)		EA	REF									3-46	A8A5E1CR7
X1-D		SEMICONDUCTOR DEVICE, DIODE: 1N3641; (07688)		EA	REF									3-46	A8A5E1CR8
X1-D		SEMICONDUCTOR DEVICE, DIODE: 1N3641; (07688)		EA	REF									3-6	A8A5E1CR9
X1-D		SEMICONDUCTOR DEVICE, DIODE: 1N3641; (07688)		EA	REF									3-46	A8A5E1CR10
X1-D		SEMICONDUCTOR DEVICE, DIODE: 1N3641; (07688)		EA	REF									3-6	A8A5E1CR11
X1-D		SEMICONDUCTOR DEVICE, DIODE: 1N3641; (07688)		EA	REF									3-46	A8A5E1CR12
X1-D		SEMICONDUCTOR DEVICE, DIODE: 1N3641; (07688)		EA	REF									3-46	A8A5E1CR13
X1-D		SEMICONDUCTOR DEVICE, DIODE: 1N3641; (07688)		EA	REF									3-46	A8A5E1CR14
X1-D		SEMICONDUCTOR DEVICE DIODE: 1N3641; (07688)		EA	REF									3-46	A8A5E1CR15
X1-D		SEMICONDUCTOR DEVICE, DIODE: 1N3641; (07688)		EA	REF									3-46	ARA5E1CR16
X1-D		SEMICONDUCTOR DEVICE, DIODE: 1N3641; (07688)		EA	REF									3-46	A8A5E1CR17
X1-D		CONDUCTOR DEVICE, DIODE: 1N3641; (07688)		EA	REF									3-46	A8A5E1CR18
X1-D		SEDCONDUCTOR DEVICE, DIODE: 1N3641; (07688)		EA	REF									3-46	A8A5E1CR19
X1-D		SEMCOIILUCTOR DEVICE, DIODE: 1N3641; (07688)		EA	REF									3-46	A8A5E1CR20
X1-D		SEMICONDUCTOR DEVICE, DIODE: 1N3641; (07688)		EA	REF									3-46	A8A5E1CR21
X1-D		SEMICONDUCTOR DEVICE, DIODE: 1N3641; (07688)		EA	REF									3-46	A8A5E1CR22
X1-D		SEMICONDUCTOR DEVICE, DIODE: 1N3641; (07688)		EA	REF									3-46	A8A5E1CP23
X1-D		SEMICONDUCTOR DEVICE, DIODE: 1N3641; (07688)		EA	REF									3-46	A8A5E1CR24

REPAIR PARTS FOR DIRECT SUPPORT, GENERAL SUPPORT, AND DEPOT MAINTENANCE (CONTINUED)															
(1) SMR CODE	(2) FEDERAL STOCK NUMBER	(3) DESCRIPTION Reference Number & Mfr. Code Usable on Code		(4) UNIT OF MEAS	(5) QTY INC IN UNIT	(6) 30 DAY DS MAINTENANCE ALLOWANCE			(7) 30 DAY GS MAINTENANCE ALLOWANCE			(8) 1 YR ALW PER 100 EQUIP CNTGCT	(9) DEPOT MAINT ALW PER 100 EQUIP	(10) ILLUSTRATION	
						(a) 1-20	(b) 21-50	(c) 51-100	(a) 1-20	(b) 21-50	(c) 51-100			(a) FIG NO.	(b) ITEM NO. OR REFERENCE DESIGNATION
X1-D		SEMICONDUCTOR DEVICE, DIODE: 1N3641, (07688)		EA	REF									3-46	A8A5E1CR25
P--H-T	5820-950-4464	POWER SUPPLY SUBASSEMBLY-2: 519-5823-003, (13499)		EA	1				*	*	*	*	*	3-11	A8A5E2
P--D	5305-054-5649	SCREW, MACHINE: MS51957-15, (96906)		EA	4							*	*		A8A5E2H4
X1-D		BOARD, PRINTED CIRCUIT: 549-5825-003, (13499)		EA	1									3-48	A8A5E2E1
X1-D		CAPACITOR, FIXED, PAPER: SDB1K03154M, (53021)		EA	1									3-48	A8A5E2C2
X1-D		RESISTOR, FIXED, COMPOSITION: RCR20G474JS; (813149)		EA	2									3-48	A8A5E2R2
X1-D		RESISTOR, FIXED, COMPOSITION: RCR20G0474JS; (81349)		EA	REF									3-48	A8A5E2R5
X1-D		RESISTOR, FIXED, COMPOSITION: RCR32G123KS, (81349)		EA	1									3-48	A8A5E2R1
X1-D		RESISTOR, FIXED, COMPOSITION: RCR32G104KS, (81349)		EA	1									3-48	A8A5E2R17
X1-D		RESISTOR, FIXED, COMPOSITION: RCR32G224KS; (81349)		EA	1									3-48	A8A5E2R16
X1-D		RESISTOR, FIXED, CPOSWWITON: RCR32G684KS; (81349)		EA	1									3-48	A8A5E2R15
P-H-T	6130-088-1380	POWER SUPPLY SUBASSEMBLY-3: 549-5827-003, (13499)		EA	1				*	*	*	*	*	3-45	A8A5E3
P--D	5310-614-3500	NUT, SELF-LOCKING, HEXAGON: 68-1660-40, (72962)		EA	2							REF	REF		A8A5E3H2
P--D	5305-763-7822	SCREW, MACHINE: MS51959-14, (96906)		EA	2							REF	REF		A8A5E3H2
P-D		WASHER, FLAT: 310-6340-000, (79807)		EA	2							REF	REF		A8A5E3H2
X1-D		BOARD, - TERMINAL NO. 3: 549-5829-003, (13499)		EA	1									3-49	A8A5E3E1
X1-D		SEMICONDUCTOR DEVICE, DIODE: 1N3641, (07688)		EA	8									3-49	A8A5E3CR1
X1-D		SEMICONDUCTOR DEVICE, DIODE: 1N3641; (07688)		EA	REF									3-49	A8A5E3CR2
X1-D		SEMICONDUCTOR DEVICE, DIODE: 1N3641, (07688)		EA	REF									3-49	A8A5E3CR3
X1-D		SEMICONDUCTOR DEVICE, DIODE: 1N3641, (07688)		EA	REF									3-49	A8A5E3CR4
X1-D		SEMICONDUCTOR DEVICE, DIODE: 1N3641, (07688)		EA	REF									3-49	A8A5E3CR26
X1-D		SEMICONDUCTOR DEVICE, DIODE: 1N3641, (07688)		EA	REF									3-49	ABA5E3CR27
X1-D		SEMICONDUCTOR DEVICE, DIODE: 1N3641, (07688)		EA	REF									3-49	A8A5E3CR28
X1-D		SEMICONDUCTOR DEVICE, DIODE: 1N3641, (07688)		EA	REF									3-49	A8A5E3CR29
P-D	5950-984-2278	REACTOR: A12408, (70674)		EA	1							5	2	3-45	A8A5L1

SECTION II

TM 11-5820-509-35

REPAIR PARTS FOR DIRECT SUPPORT, GENERAL SUPPORT, AND DEPOT MAINTENANCE (CONTINUED)															
(1) SMR CODE	(2) FEDERAL STOCK NUMBER	(3) DESCRIPTION Reference Number & Mfr. Code Usable on Code		(4) UNIT OF MEAS	(5) QTY INC IN UNIT	(6) 30 DAY DS MAINTENANCE ALLOWANCE			(7) 30 DAY GS MAINTENANCE ALLOWANCE			(8) 1 YR ALW PER 100 EQUIP CNTGCTY	(9) DEPOT MAINT ALW PER 100 EQUIP	(10) ILLUSTRATION	
						(a)	(b)	(c)	(a)	(b)	(c)			(a) FIG NO.	(b) ITEM NO. OR REFERENCE DESIGNATION
						1-20	21-50	51-100	1-20	21-50	51-100				
P--D	5305-685-1490	SCREW, MACHINE P330-2290-000; (77250)		EA	2							REF	REF		A8A5L1H1
P--D	5305-685-1490	SCREW, MACHINE: P330-2290-000, (77250)		EA	REF							REF	REF		A8A5L1H2
P--D	6110-960-7341	REGULATOR SUBASSEMBLY, VOLTAGE 553-9717-004, (13499)		EA	1							*	*	3-50	A8A5TB1
P--D	5305-054-5648	SCREW, MACHINE: MS51957-14, (96906)		EA	1							REF	REF		A8A5TB1H1
P--D	5310-058-3599	WASHER, LOCK: MS35335-51; (96906)		EA	1							REF	REF		A8A5TB1H1
X1-D		BRACKET, VOLTAGE REGULATOR: 553-9716-003, (13499)		EA	1										A8A5TB1MP1
X1-D		HOLDER, TRANSISTOR: A51043; (08289)		EA	2										A8A5TB1MP2
X1-D		HOLDER, TRANSISTOR: A51043, (08289)		EA	REF										A8A5TB1MP3
X1-D		RESISTOR, FIXED, FILM: RN60D4220F; (81349)		EA	2								3-51		A8A5TB1R21
X1-D		RESISTOR, FIXED, FILM: RN60DD220F; (81349)		EA	REF								3-51		A8A5TB1R23
X1-D		RESISTOR, FIXED, FILM: RN60D4640F, (81349)		EA	1								3-51		A8A5TB1R19
X1-D		RESISTOR, FIXED, FILM: RN60D2151F, (81349)		EA	1								3-51		ABA5TB1R20
X1-D		SEMICONDUCTOR DEVICE, DIODE: 1N757, (07688)		EA	1								3-51		A8A5TB1CR31
X1-D		TERMINAL, LUG: 2104-04-01-2520N; (78189)		EA	1										A8A5TB1E1
X1-D		NUT, SELF-LOCKING, HEXAGON: MS21044D04, (96906)		EA	1										A8A5TB1E1H1
X1-D		SCREW, MACHINE: MS51957-14, (96906)		EA	1										A8A5TB1E1H2
X1-D		TRANSISTOR: 2N697, (07688)		EA	2								3-51		A8A5TB1Q1
X1-D		TRANSISTOR: 2N697, (07688)		EA	REF								3-51		A8A5TB1Q2
X1-D		TRANSISTOR: 211485; (07688)		EA	1								3-51		A8A5TB1Q3
X1-D		NUT, SELF-LOCKING, HEXAGON: MS21044D04, (96906)		EA	2										A8A5TB1Q3H1
X1-D		NUT, SELF-LOCKING, HEXAGON: MS21044DO; (96906)		EA	REF										A8A5TB1Q3H2
X1-D		SCREW, MACHINE: MS51957-5, (96906)		EA	2										A8A5TB1Q3H3
X1-D		SCREW, MACHINE: MS51957-15; (96906)		EA	REF										A8A5TB1Q3H4
X1-D		WASHER, FLAT: 504-0730-003, (13499)		EA	2										A8A5TB1Q3H5
X1-D		WASHER, FLAT: 504-0730-003, (13499)		EA	REF										A8A5TB1Q3H6

REPAIR PARTS FOR DIRECT SUPPORT, GENERAL SUPPORT, AND DEPOT MAINTENANCE (CONTINUED)															
(1) SMR CODE	(2) FEDERAL STOCK NUMBER	(3) DESCRIPTION Reference Number & Mfr. Code Usable on Code		(4) UNIT OF MEAS	(5) QTY INC IN UNIT	(6) 30 DAY DS MAINTENANCE ALLOWANCE			(7) 30 DAY GS MAINTENANCE ALLOWANCE			(8) 1 YR ALW PER 100 EQUIP CNTGCTY	(9) DEPOT MAINT ALW PER 100 EQUIP	(10) ILLUSTRATION	
						(a)	(b)	(c)	(a)	(b)	(c)			(a) FIG NO.	(b) ITEM NO. OR REFERENCE DESIGNATION
						1-20	21-50	51-100	1-20	21-50	51-100				
X1-D		WASHER, NONMETALLIC: 302-0024-00C, (05284)		EA	2										A8A5TB1Q3H7
X1-D		WASHER, NONMETALLIC: 302-0024-000; (05284)		EA	REF										A8A5TB1Q3H8
P--D	5945-984-1796	RELAY, ARMATURE: 45-4594, (04221)		EA	1						*	*	3-50	A8A5K1	
P--D	5305-777-6039	SCREW, MACHINE: MS51959-12, (96906)		EA	2						REF	REF		A8A5K1H1	
P--D	5305-777-6039	SCREW, MACHINE: MS51959-12, (96906)		EA	REF						REF	REF		A8A6K1H2	
P--D	5905-900-0431	RESISTOR, FIXED, COMPOSITION: RCR20G473KS, (81349)		EA	1						*	*	3-45	A8A5R14	
P--D	5905-221-5860	RESISTOR, FIXED, COMPOSITION: RCR200334KS, (81349)		EA	1						*	*	3-45	A8A5R12	
P--D	5905-279-1979	RESISTOR, FIXED, COMPOSITION: RC42GF101K, (81349)		EA	1						*	*	3-45	A8A5R9	
P--D		RESISTOR, FIXED, COMPOSITION: RC42GF104K, (81349)		EA	1						*	*	3-45	A8A5R10	
P--D		RESISTOR, FIXED, COMPOSITION: RC42GF105K, (81349)		EA	2						*	*	3-45	A8A5R6	
P--D		RESISTOR, FIXED, COMPOSITION: RC42GF105K, (81349)		EA	REF						REF	REF	3-45	A8A5R7	
P--D	5905-982-3329	RESISTOR, FIXED, WIRE WOUND: RW69V221, (81349)		EA	1						*	*	3-45	A8A5R24	
P--D	5905-088-0635	RESISTOR, FIXED, WIRE WOUND: RW69V471, (81349)		EA	1						*	*	3-45	A8A5R11	
P--D	5905-819-1340	RESISTOR, VARIABLE, WIRE WOUND: 224L1-201, (80294)		EA	1						*	*	3-11	A8A5R22	
P--D		SCREW, MACHINE: 330-2352-000, (70601)		EA	1						REF	REF		A8A5R22H1	
P--D	5305-054-5638	SCREW, MACHINE: MS51957-4, (96906)		EA	1						REF	REF		A8A5R22H2	
P--D	5310-275-9230	WASHER, FLAT: 310-0044-000, (79807)		EA	1						REF	REF		A8A5R22H3	
P--D	5310-551-9286	WASHER, NONMETALLIC: 302-0023-000, (05284)		EA	1						*	*		A8A5R22H4	
P--D		RESISTOR, VARIABLE, WIRE WOUND: 224L1-503, (80294)		EA	1						*	*	3-11	A8A5R3	
P--D		SCREW, MACHINE: 330-2352-000, (70601)		EA	1						REF	REF		A8A5R3K1	
P--D	5305-054-5638	SCREW, MACHINE: MS51957-4, (96906)		EA	1						REF	REF		A8A5R3H2	
P--D	5310-275-9230	WASHER, FLAT: 310-0044-000, (79807)		EA	1						REF	REF		A8A5R3H3	
P--D	5310-551-9286	WASHER, NONMETALLIC: 302-0023-000, (05284)		EA	1						REF	REF		A8A5R3H4	
P--D	5905-682-1379	RESISTOR, VARIABLE, WIRE WOUND: 224L2-104, (80294)		EA	1						*	*	3-11	A8A5R4	
P--D		SCREW, MACHINE: 330-2352-000; (70601)		EA	1						REF	REF		A8A544H1	

REPAIR PARTS FOR DIRECT SUPPORT, GENERAL SUPPORT, AND DEPOT MAINTENANCE (CONTINUED)															
(1) SMR CODE	(2) FEDERAL STOCK NUMBER	(3) DESCRIPTION Reference Number & Mfr. Code Usable on Code		(4) UNIT OF MEAS	(5) QTY INC IN UNIT	(6) 30 DAY DS MAINTENANCE ALLOWANCE			(7) 30 DAY GS MAINTENANCE ALLOWANCE			(8) 1 YR ALW PER 100 EQUIP CNTGCTY	(9) DEPOT MAINT ALW PER 100 EQUIP	(10) ILLUSTRATION	
						(a)	(b)	(c)	(a)	(b)	(c)			(a) FIG NO.	(b) ITEM NO. OR REFERENCE DESIGNATION
						1-20	21-50	51-100	1-20	21-50	51-100				
P--D	5305-054-5638	SCREW, MACHINE: MS51957-4; (96906)		EA	1							REF	REF		A8A5R4H2
P--D	5310-275-9230	WASHER, FLAT: 310-0044-000, (79807)		EA	1							REF	REF		A8A5R4H3
P--D	5310-551-9286	WASHER, NONMETALLIC: 302-0023-000, (05284)		EA	1							REF	REF		A8A5R4H4
P--D	5910-986-7754	RETAINER, CAPACITOR: 549-5813-003, (13499)		EA	1							*	*		A8A5MP9
P--D	5305-054-6652	SCREW, MACHINE: MS51957-28; (96906)		EA	1							*	*		A8A5MP9H1
P--D	5310-531-9514	WASHER, FLAT: 310-6360-000, (79807)		EA	1							REF	REF		A8A5MP9H2
P--D	5935-840-5485	SOCKET, ELECTRON TUBE: 88-8TM, (02660)		EA	2							*	*	3-45	A8A5XC19
P--D	5310-614-3500	NUT, SELF-LOCKING, HEXAGON: 68-1660-40, (72962)		EA	2							REF	REF		A8A5XC19H1
P--D	5310-611-3500	NUT, SELF-LOCKING, HEXAGON: 68-1660-40; (72962)		EA	REF							REF	REF		A8A5XC19H2
P--D	5305-685-1490	SCREW, MACHINE: P330-2290-000; (77250)		EA	2							REF	REF		A8A5XC19H3
P--D	5305-685-1490	SCREW, MACHINE: P330-2290-000, (77250)		E/	REF							REF	REF		ABA5XC19H4
P--D	5935-840-5485	SOCKET, ELECTRON TUBE: 88-8TM, (02660)		EA	REF							REF	REF	3-45	A8A5XC20
P--D	5310-614-3500	NUT, SELF-LOCKING, HEXAGON: 68-1660-10; (72962)		EA	1							REF	REF		A8A5XC20H1
P--D	5305-685-1490	SCREW, MACHINE: P330-2290-000; (77250)		EA	2							REF	REF		A8A5XC20H2
P--D	5305-685-1490	SCREW, MACHINE: P330-2290-000, (77250)		EA	REF							REF	REF		A8ASXC20H3
P--D	5310-058-3599	WASHER, LOCK: MS35335-51; (96906)		EA	1							REF	REF		A8ASXC20H4
P--D	5340-975-7637	TERMINAL, GROUND: 549-5709-002; (13499)		EA	1							REF	REF		A8A5E4
P--D	5305-685-1490	SCREW, MACHINE: P330-2290-000; (77250)		EA	1							REF	REF		A8A5E4H1
P--D		WASHER, LOCK: MS35338-135; (96906)		EA	1							REF	REF		A8A5E14H2
P--D		TERMINAL, LUG: 4040-2HT; (77147)		EA	1							REF	REF		A8A5E5
P--D	5310-938-20 13	NUT, PLAIN, HEXAGON: MS35649-224; (96906)		EA	1							*	*		A8A5E5H1
P--D		SCREW, MACHINE: P330-2285-000; (77250)		EA	1							*	*		A8A5E5H2
P--D	5310-928-2690	WASHER, LOCK: MS35338-134; (96906)		EA	1							REF	REF		A8A5E5H3
P--D		TERMINAL, LUG: 2104-04-01-2520N; (78189)		EA	1							REF	REF		A8A5E6
P--D	5310-275-0889	NUT, PLAIN, HEXAGON: P313-0132-000; (77250)		EA	1							REF	REF		A8A5E6H1

SECTION II

TM 11-5820-509-35

REPAIR PARTS FOR DIRECT SUPPORT, GENERAL SUPPORT, AND DEPOT MAINTENANCE (CONTINUED)															
(1) SMR CODE	(2) FEDERAL STOCK NUMBER	(3) DESCRIPTION Reference Number & Mfr. Code Usable on Code		(4) UNIT OF MEAS	(5) QTY INC IN UNIT	(6) 30 DAY DS MAINTENANCE ALLOWANCE			(7) 30 DAY GS MAINTENANCE ALLOWANCE			(8) 1 YR ALW PER 100 EQUIP CNTGCTY	(9) DEPOT MAINT ALW PER 100 EQUIP	(10) ILLUSTRATION	
						(a) 1-20	(b) 21-50	(c) 51-100	(a) 1-20	(b) 21-50	(c) 51-100			(a) FIG NO.	(b) ITEM NO. OR REFERENCE DESIGNATION
P--D	5305-054-5647	SCREW, MACHINE: MS51957-13; (96906)		EA	1							REF	REF		A8A5E17H2
P--D		WASHER, LOCK: MS35338-135; (96906)		EA	1							REF	REF		A8A5E17H3
P--D	5940-259-8457	TERMINAL, STUD: RTMT12M; (91663)		EA	5							REF	REF		A8A5E7
P--D	5305-054-5646	SCREW, MACHINE: MS51957-12; (96906)		EA	1							REF	REF		A8A5E7H1
P--D	5940-259-8457	TERMINAL, STUD: RTMT12M; (91663)		EA	REF							REF	REF	3-45	A8A5E8
P--D	5940-259-8457	TERMINAL, STUD: RTWT12M; (91663)		EA	REF							REF	REF		A8A5E9
P--D	5305-777-6039	SCREW, MACHINE: MS51959-12; (96906)		EA	1							REF	REF		A8A50H1
P--D	5940-259-8457	TERMINAL, STUD: RTMT12M; (91663)		EA	REF							REF	REF		A8A5E10
P--D	5305-777-6039	SCREW, MACHINE: MS51959-12; (96906)		EA	1							REF	REF		A8A5E10H1
P--D	5940-259-8457	TERMINAL, STUD: RTWT12M; (91663)		EA	REF							REF	REF	3-45	A8A5E11
P--D	5940-255-3907	TERMINAL, STUD 504-7415-002; (13499)		EA	1							*	*		A8A5E18
P--D	5305-054-5646	SCREW, MACHINE: MS51957-12; (96906)		EA	1							REF	REF		A8A5E18H1
P--D		WASHER, LOCK: MS35338-135; (96906)		EA	1							REF	REF		ABA5E18H2
P--D	5950-432-6475	TRANSFORMER, POWER, STEP-DOWN: 526-6052-001; (13499)		EA	1							*	*	3-45	A8A5T2
P--D	53106-8660	NUT, PLAIN, HEXAGON: P313-0045-000; (77250)		EA	1							*	*		A8A5T2H1
P--D	5305-054-6660	SCREW, MACHINE: MS51957-36; (96906)		EA	1							*	*		A8A5T2H2
P--D	5310-275-1347	WASHER, FLAT: 310-0046-000; (79807)		EA	2							REF	REF		A8A5T2H3
P--D	5310-275-1347	WASHER, FLAT: 310-0046-000; (79807)		EA	REF							REF	REF		A8A5T2H4
P--D	5310-929-6395	WASHER, LOCK: 310-0071-000; (79807)		EA	1							*	*		A8AST2HR5
P--D	5950-982-3748	TRANSFORMER, POWER: BC3069; (97315)		EA	1							*	*	3-11	A8A5T1
P--D	5305-763-6963	SCREW, MACHINE: MS51959-28; (96906)		EA	2							*	*		A8A5T1H1
P--D	5305-763-6963	SCREW, MACHINE: MS51959-28; (96906)		EA	REF							REF	REF		A8A5T1H2
P--D	5305-054-6653	SCREW, MACHINE: MS51957-29; (96906)		EA	2							REF	REF		A8A5T1H3
P--D	5305-054-6653	SCREW, MACHINE: MS51957-29; (96906)		EA	REF							REF	REF		A8A5T1H4
A-H-T		CHASSIS, ELECTRICAL EQUIPMENT: CH474PRC47, (80058)		EA	1										A8A4

REPAIR PARTS FOR DIRECT SUPPORT, GENERAL SUPPORT, AND DEPOT MAINTENANCE (CONTINUED)															
(1) SMR CODE	(2) FEDERAL STOCK NUMBER	(3) DESCRIPTION Reference Number & Mfr. Code Usable on Code		(4) UNIT OF MEAS	(5) QTY INC IN UNIT	(6) 30 DAY DS MAINTENANCE ALLOWANCE			(7) 30 DAY GS MAINTENANCE ALLOWANCE			(8) 1 YR ALW PER 100 EQUIP CNTGCTY	(9) DEPOT MAINT ALW PER 100 EQUIP	(10) ILLUSTRATION	
						(a)	(b)	(c)	(a)	(b)	(c)			(a) FIG NO.	(b) ITEM NO. OR REFERENCE DESIGNATION
						1-20	21-50	51-100	1-20	21-50	51-100				
P--D	5330-558-2310	GASKET, O-RING: MS9021-013; (96906)		EA	5							*	*		A8A4H5
P--D	5305-78-9882	SCREW, SEALING: 548-7976-003; (13499)		EA	5							*	*		A8A4H5
P--D		ADAPTER, CABLE: YE1620F32, (09922)		EA	3							REF	REF		A8A4E9
P--D		ADAPTER, CABLE: YE1620F32; (09922)		EA	REF							REF	REF		A8A4E10
P--D		ADAPTER, CABLE: YE1620F32; (09922)		EA	REF							REF	REF		A8A4E11
P--D	5940-728-3622	ADAPTER, CABLE: YE1216F32; (09922)		EA	2							*	*		A8A4E2
P--D	5940-728-3622	ADAPTER, CABLE: YE1216F32; (09922)		EA	REF							REF	REF		A8A4E13
P--D	5935-892-9923	ADAPTER, PIN TO CONNECTOR: 549-6148-002; (13499)		EA	6										A8A4E14
P--D	5935-892-9923	ADAPTER, PIN TO CONNECTOR: 549-6148-002; (13499)		EA	REF							REF	REF		A8AhE15
P--D	5935-892-9923	ADAPTER, PIN TO CONNECTOR: 549-6148-002; (13499)		EA	REF							REF	REF		A8A4E16
P--D	5935-892-9923	ADAPTER, PIN TO CONNECTOR: 549-6148-002; (13499)		EA	REF							REF	REF		A8A4E17
P--D	5935-892-9923	ADAPTER, PIN TO CONNECTOR: 549-6148-002; (13499)		EA	REF							REF	REF		A8A4E18
P--D	5935-892-9923	ADAPTER, PIN TO CONNECTOR: 549-6148-002; (13499)		EA	REF							REF	REF		A8A4E19
P--D	6625-984-1076	AMMETER, DC: 59-7159; (11707)		EA	1							.	*		ABA4M01
P-D	5305-182-9459	SCREW, MACHINE: P343-0023-000, (77250)		EA	4							*	*		A8A4K101H1
P-D		SCREW, MACHINE: P343-0023-000; (77250)		EA	REF							REF	REF		A8A4M101H2
P--D		SCREW, MACHINE: P343-0023-000; (77250)		EA	REF							REF	REF		A8A4101H3
P--D		SCREW, MACHINE: P343-0023-000, (77250)		EA	REF							REF	REF		A8A4M101H4
P--H-T	5820-168-1598	AMPLIFIER SUBASSEMBLY: 549-6230-004; (13499)		EA	1				*	*	*	*	*		A8A4A
P--D	5305-054-6652	SCREW, MACHINE: MS51957-28; (96906)		EA	2							REF	REF		A8A4A1H2
P--D	5305-054-6651	SCREW, MACHINE: MS51957-27; (96906)		EA	2							REF	REF		A8A4A1H2
X1-D		CAPACITOR, FIXED, CERAMIC: 20C95; (56289)		EA	1									3-66	A8A4A1C101
X1-D		CAPACITOR, FIXED, CERAMIC: 36C228A3; (56289)		EA	1									3-66	A8A4AC139
X1-D		CAPACITOR, FIXED, CERAMIC: CK13BX103M; (81349)		EA	2									3-66	A8A4A1C125
X1-D		CAPACITOR, FIXED, CERAMIC: CK13BX103M; (81349)		EA	REF									3-66	A8A4A1C126

SECTION II

TM 11-5820-509-35

REPAIR PARTS FOR DIRECT SUPPORT, GENERAL SUPPORT, AND DEPOT MAINTENANCE (CONTINUED)															
(1) SMR CODE	(2) FEDERAL STOCK NUMBER	(3) DESCRIPTION Reference Number & Mfr. Code Usable on Code		(4) UNIT OF MEAS	(5) QTY INC IN UNIT	(6) 30 DAY DS MAINTENANCE ALLOWANCE			(7) 30 DAY GS MAINTENANCE ALLOWANCE			(8) 1 YR ALW PER 100 EQUIP CNTGCTY	(9) DEPOT MAINT ALW PER 100 EQUIP	(10) ILLUSTRATION	
						(a)	(b)	(c)	(a)	(b)	(c)			(a) FIG NO.	(b) ITEM NO. OR REFERENCE DESIGNATION
						1-20	21-50	51-100	1-20	21-50	51-100				
X1-D		CAPACITOR, FIXED, CERAMIC: HTS127-2000Z; (00656)		EA	1									3-66	A8A4A1C141
X1-D		CAPACITOR, FIXED, CERAMIC: 6S8084; (56289)		EA	2									3-66	A8A4A1C103
X1-D		CAPACITOR, FIXED, CERAMIC: 6S8084, (56289)		EA	REF									3-66	A8A4A1C104
X1-D		CAPACITOR, FIXED, CERAMIC: CM05ED680J03; (81349)		EA	1									3-66	A8A4A1C140
X1-D		CHASSIS, ELECTRICAL EQUIPMENT: 549-6219-003; (13499)		EA	1										A8A4A1A1
X1-D		SCREW, MACHINE: P343-0172-00; (77250)		EA	2										A8A4A1A1H2
X1-D		WASHER, FLAT: 310-0046-000; (79807)		EA	1										A8A4A1A1H1
X1-D		WASHER, NONMETALLIC: 302-0026-000; (05284)		EA	4										A8A4A1A1H4
X1-D		JACK, TIP: 72-140-1; (12615)		EA	1								3-66		A8A4A1A1J1
X1-D		JACK, TIP: 72-140-2; (12615)		EA	1								366		A8A4A1A1J2
X1-D		JACK, TIP: 72-140-3; (12615)		EA	1								366		A8A4A1A1J3
X1-D		JACK, TIP: 72-140-4; (12615)		EA	1								3-66		A8A4A1A1J4
XL-D		JACK, TIP: 72-140-5; (12615)		EA	1								3-66		A8A4A1A1J5
X1-D		CHASSIS, ELECTRICAL EQUIPMENT: 549-6221-003; (13499)		EA	1										A8A4A1MP1
X1-D		SCREW, MACHINE: P343-0172-00; (77250)		EA	2										A8A4hAMP1H1
X1-D		SCREW, MACHINE: P343-0172-00; (77250)		EA	REF										A8A4A1MP1H2
X1-D		WASHER, FLAT: 310-0046-000; (79807)		EA	2										A8A4A1MP1H3
X1-D		WASHER, FLAT: 310-0046-000; (79807)		EA	REF										A8A4A1MP1H4
X1-D		WASHER, NONMETALLIC: 302-0026-000, (052814)		EA	4										A8A4A1MP1H5
X1-D		WASHER, NONMETALLIC: 302-0026-000, (05284)		EA	REF										A8A4A1MP1H6
X1-D		WASHER, NONMETALLIC: 302-0026-000, (05284)		EA	REF										A8A4A1MP1H7
X1-D		WASHER, NONMETALLIC: 302-0026-000; (05284)		EA	REF										A8A4A1MP1H8
X1-D		COIL, RADIO FREQUENCY: MS16221-1, (96906)		FA	2								3-66		A8A4A1L120
X1-D		COIL, RADIO FREQUENCY: MS16221-1; (96906)		EA	REF								3-66		A8A4A1L121
X1-D		COIL, RADIO FREQUENCY: LT10K043; (81349)		EA	1								3-66		A8A4AL102

REPAIR PARTS FOR DIRECT SUPPORT, GENERAL SUPPORT, AND DEPOT MAINTENANCE (CONTINUED)															
(1) SMR CODE	(2) FEDERAL STOCK NUMBER	(3) DESCRIPTION Reference Number & Mfr. Code Usable on Code		(4) UNIT OF MEAS	(5) QTY INC IN UNIT	(6) 30 DAY DS MAINTENANCE ALLOWANCE			(7) 30 DAY GS MAINTENANCE ALLOWANCE			(8) 1 YR ALW PER 100 EQUIP CNTGCT	(9) DEPOT MAINT ALW PER 100 EQUIP	(10) ILLUSTRATION	
						(a) 1-20	(b) 21-50	(c) 51-100	(a) 1-20	(b) 21-50	(c) 51-100			(a) FIG NO.	(b) ITEM NO. OR REFERENCE DESIGNATION
X1-D		COIL, RADIO FREQUENCY: LT10K053, (81349)		EA	1									3-66	A8A4A1L103
X1-D		RESISTOR, FIXED, COMPOSITION: RCR20C103KS, (81349)		EA	2									3-66	A8A4A1R102
X1-D		RESISTOR, FIXED, COMPOSITION: RCR20CG103KS; (81349)		EA	REF									3-66	ABA4A1R103
X1-D		RESISTOR, FIXED, COMPOSITION: RCR20G273KS, (81349)		EA	1									3-66	A8A4A1R119
X1-D		RESISTOR, FIXED, COMPOSITION: RCR32G222KS, (81349)		EA	1									3-66	A8A4A1R116
X1-D		RESISTOR, FIXED, COMPOSITION: RCR32G473KS, (81349)		EA	1									3-66	A8A4AR104
X1-D		RESISTOR, FIXED, CO4POSITION: RCR32G125KS; (81349)		EA	1									3-66	A8A4AIR115
X1-D		RESISTOR, FIXED, COMPOSITION: RC42GF101K, (81349)		EA	1									3-66	A8A4AIR108
X1-D		SEMICONDUCTOR DEVICE, DIODE: JAN1N663, (81350)		EA	1									3-66	AA4A1CR101
X1-D		SOCKET, ELECTRON TUBE: 122-248-202, (74970)		EA	1										A8A4A1XV101
X1-D		TERMINAL, LUG: 614B, (57714)		EA	1										A8A4A1E1
P--D	5905-251-6530	ATTENUATOR, VARIABLE: 28156, (01121)		EA	1							*	*		A8A4R11
P--D	5975-987-8829	BOOT, DUST AND MOISTURE SEAL: N9033-1-4, (97539)		EA	1							*	*		A8A4R11R1
P--D	6250-984-1092	BASE, LAMPHOLDER: 549-6141-002, (13499)		EA	1							*	*		A8A4A2
P--D	5305-616-2568	SCREW, MACHINE: P34 3-0285-000, (77250)		EA	2							REF	REF		A8A4A2H2
P--D		WASHER, LOCK: 1804-00, (78189)		EA	2							*	*		A8A4A2H2
X1-D		BUSHING, SLEEVE: 549-6139-002, (13499)		EA	2										A8A4A24PI
X1-D		BUSHING, SLEEVE: 549-6139-002, (13499)		EA	REF										A8A4A2MP2
X1-D		PLATE, MOUNTING, LAMPHOLDER: 549-6140-002, (13499)		EA	1										A8A4A24P3
P--D	3120-709-5460	BEARING, SLEEVE: 6L2FF; (96881)		EA	6							*	*		A8A4P1
P--D	3120-709-5460	BEARING, SLEEVE: 6L2FF; (96881)		EA	REF							REF	REF		A8A4MP2
P--D	3120-709-5460	BEARING, SLEEVE: 6L2FF; (96881)		EA	REF							REF	REF		A8A4MP3
P--D	3120-709-5460	BEARING, SLEEVE: 6L2FF; (96881)		EA	REF							REF	REF		A8A4MP4
P--D	3120-709-5460	BEARING, SLEEVE: 6L2FF; (96881)		EA	REF							REF	REF		A8A4MP5
P--D	3120-709-5460	BEARING, SLEEVE: 6L2FF; (96881)		EA	REF							REF	REF		AF8A4P6

REPAIR PARTS FOR DIRECT SUPPORT, GENERAL SUPPORT, AND DEPOT MAINTENANCE (CONTINUED)															
(1) SMR CODE	(2) FEDERAL STOCK NUMBER	(3) DESCRIPTION Reference Number & Mfr. Code Usable on Code		(4) UNIT OF MEAS	(5) QTY INC IN UNIT	(6) 30 DAY DS MAINTENANCE ALLOWANCE			(7) 30 DAY GS MAINTENANCE ALLOWANCE			(8) 1 YR ALW PER 100 EQUIP CNTGCTY	(9) DEPOT MAINT ALW PER 100 EQUIP	(10) ILLUSTRATION	
						(a) 1-20	(b) 21-50	(c) 51-100	(a) 1-20	(b) 21-50	(c) 51-100			(a) FIG NO.	(b) ITEM NO. OR REFERENCE DESIGNATION
P--D	3120-793-6354	BEARING, SLEEVE: 8L2FF, (96881)		EA	2							*	*		A8A4P7
P--D	3120-793-6354	BEARING, SLEEVE: 8L2FF, (96881)		EA	REF							REF	REF		A8A4MP8
P--D	6740-618-6314	BEARING, SLEEVE: 4L4F; (96881)		EA	1							*	*		A8A4MP9
M--D		BLOCK, MOUNTING-REAR: 549-6167-002; (13499)		EA	2										A8A4MP10
P--D	5305-937-2556	SCREW, MACHINE: P330-2296-000; (77250)		EA	2							*	*		A8A4MP10H1
P--D	5305-937-2566	SCREW, MACHINE: P330-2296-000, (77250)		EA	REF							REF	REF		A8A4MP10H2
M--D		BLOCK, MOUNTING-REAR: 549-6167-002; (13499)		EA	REF										A8A4MP11
P--D	5305-937-2566	SCREW, MACHINE: P330-2296-000; (77250)		EA	2							REF	REF		A8A4MP11H1
P--D	5305-937-2566	SCREW, MACHINE: P330-2296-000, (77250)		EA	REF							REF	REF		A8A4MP11H2
P--D		BOARD ASSEMBLY, COMPONENT, NO. 1: 549-6391-003; (13499)		EA	1							*	*	3-67	A8A4TB1
P--D	5305-054-5649	SCREW, MACHINE: MS51957-15, (96906)		EA	2							REF	REF		A8A4TB1H2
P--D		WASHER, LOCK, SPRING: MS35338-135, (96906)		EA	2							REF	REF		A8A4TB1H2
X1-D		BOARD, TERMINAL, NO. 1-FLARED: 549-6390-003, (13499)		EA	1										A8A4TB1E1
X1-D		RESISTORS, FIXED, WIRE WOUND: RW69V6R8; (81349)		EA	2										A8A4TB1R1
X1-D		RESISTOR, FIXED, WIRE WOUND: RW69V6R8; (81349)		EA	REF										A8A4TB1R2
X1-D		RESISTOR, FIXED, WIRE WOUND: RW67V471; (81349)		EA	2										A8A4TB1R3
X1-D		RESISTOR, FIXED, WIRE WOUND: RW67V471; (81349)		EA	REF										A8A4TB1R4
P--H-T	5820-984-7544	BOARD ASSEMBLY, COMPONENT, NO. 6: 549-6395-003; (13499)		EA	1				*	*	*	*	*	3-67	A8A4TB6
X1-D		BOARD, TERMINAL, NO. 6: 549-6394-003; (13499)		EA	1										A8A4TB6E1
X1-D		SCREW, MACHINE: MS51957-15; (96906)		EA	2										A8A4TB6H2
X1-D		WASHER, FLAT: 310-6325-000, (79807)		EA	2										A8A4TB6H2
X1-D		WASHER, LOCK, SPRING: MS35338-135; (96906)		EA	2										A8A4TB6H2
X1-D		CAPACITOR, FIXED, ELECTROLYTIC: 610D105M200BD5, (56289)		EA	1										A8A4TB6C1
X1-D		RESISTOR, FIXED, COMPOSITION: RC42GF562K; (81349)		EA	1										A8A4TB6R5
X1-D		RESISTOR, FIXED, FILM: RN60D6813F; (81349)		EA	1										A8A4TB6R23

REPAIR PARTS FOR DIRECT SUPPORT, GENERAL SUPPORT, AND DEPOT MAINTENANCE (CONTINUED)															
(1) SMR CODE	(2) FEDERAL STOCK NUMBER	(3) DESCRIPTION Reference Number & Mfr. Code Usable on Code		(4) UNIT OF MEAS	(5) QTY INC IN UNIT	(6) 30 DAY DS MAINTENANCE ALLOWANCE			(7) 30 DAY GS MAINTENANCE ALLOWANCE			(8) 1 YR ALW PER 100 EQUIP CNTGCTY	(9) DEPOT MAINT ALW PER 100 EQUIP	(10) ILLUSTRATION	
						(a)	(b)	(c)	(a)	(b)	(c)			(a) FIG NO.	(b) ITEM NO. OR REFERENCE DESIGNATION
						1-20	21-50	51-100	1-20	21-50	51-100				
X1-D		SEMICONDUCTOR DEVICE, DIODE: 1N2611, (07688)		EA	2										A8A4TB6CR1
X1-D		SEMICONDUCTOR DEVICE, DIODE: 1N2611, (07688)		EA	REF										A8A4TB6CR2
X1-D		SEMICONDUCTOR DEVICE, DIODE: JAN1N485B, (81350)		EA	1										A8A4TB6CR8
P--D	5940-984-1791	BOARD, TERMINAL, NO. 4-PRESSED: 549-6210-003, (13499)		EA	1						*	*	3-67		A8A4TB4
P--D	5305-054-5649	SCREW, MACHINE: MS51957-15; (96906)		EA	2						REF	REF			A8A4TB4H1
P--D	5305-05b-5649	SCREW, MACHINE: MS51957-15, (96906)		EA	REF						REF	REF			A8A4TB4H2
P--D		WASHER, FLAT: 310-6325-000, (79807)		EA	2						REF	REF			A8A4TB4H3
P--D		WASHER, FLAT: 310-6325-000, (79807)		EA	REF						REF	REF			A8A4TB4H4
P--D		WASHER, LOCK, SPRING: MS35338-135, (96906)		EA	2						REF	REF			A8A4TB4H5
P--D		WASHER, LOCK, SPRING: MS35338-135, (96906)		EA	REF						REF	REF			A8A4TB4H6
M--D		BRACKET, RELAY-PRESSED: 549-6234-003, (13499)		EA	1										A8A4MP12
P--D	5310-275-0889	NUT, PLAIN, HEXAGON: P313-0132-000, (77250)		EA	2						REF	REF			A8A4MP12H1
P--D	5310-275-3839	NUT, PLAIN, HEXAGON: P313-0132-000, (77250)		EA	REF						REF	REF			A8A4MP12H2
P--D	5305-469-5382	SCREW, MACHINE: P342-0026-000, (77250)		EA	3										A8A4MP12H3
P--D	5305-469-5382	SCREW, MACHINE: P342-0026-000, (77250)		EA	REF						REF	REF			A8A4MP12H4
P--D	5305-469-5382	SCREW, MACHINE: P342-0026-000, (77250)		EA	REF						REF	REF			A8A4MP12H5
P--D	5305-727-0833	SCREW, MACHINE: MS51959-3, (96906)		EA	1						REF	REF			A8A4MP12H6
P--D	5305-054-5648	SCREW, MACHINE: MS51957-14, (96906)		EA	1						REF	REF			A8A4MP12H7
P--D	5310-782-1349	WASHER, FLAT: 310-0045-000, (79807)		EA	2						REF	REF			A8A4MP12H8
P--D	5310-782-1349	WASHER, FLAT: 310-0045-000, (79807)		EA	REF						REF	REF			A8A4MP12H9
P--D	5310-058-2949	WASHER, LOCK, SPRING: 310-0278-000, (70318)		EA	2						REF	REF			A8A4MP12H10
P--D	5310-058-2949	WASHER, LOCK, SPRING: 310-0278-000, (70318)		EA	REF						REF	REF			A8A4MP12H11
M--D		BUSHING, SCREW THREAD: 553-9271-003, (13499)		EA	1										A8A4MP13
P--D		NUT, PLAIN, HEXAGON: P334-4060-00, (77250)		EA	1										ABA4MP13H1
P--D	5310-209-1522	WASHER, LOCK 1220-02, (78189)		EA	1										A8A4MP13H2

REPAIR PARTS FOR DIRECT SUPPORT, GENERAL SUPPORT, AND DEPOT MAINTENANCE (CONTINUED)															
(1) SMR CODE	(2) FEDERAL STOCK NUMBER	(3) DESCRIPTION Reference Number & Mfr. Code Usable on Code		(4) UNIT OF MEAS	(5) QTY INC IN UNIT	(6) 30 DAY DS MAINTENANCE ALLOWANCE			(7) 30 DAY GS MAINTENANCE ALLOWANCE			(8) 1 YR ALW PER 100 EQUIP CNTGCTY	(9) DEPOT MAINT ALW PER 100 EQUIP	(10) ILLUSTRATION	
						(a)	(b)	(c)	(a)	(b)	(c)			(a) FIG NO.	(b) ITEM NO. OR REFERENCE DESIGNATION
						1-20	21-50	51-100	1-20	21-50	51-100				
P--D	5310-674-7630	BUTTON, CABLE: 541-5179-00; (13499)		EA	1							REF	REF		A8A4MP14
P--D	5305-763-7822	SCREW, MACHINE: MS51959-14, (96906)		EA	1							REF	REF		A8A4MP14H1
P--D	5821-658-3718	BUTTON, CABLE: 541-5181-002, (13499)		EA	1							*	*		A8A41P15
P--D	5305-770-2579	SCREW, MACHINE: P330-2292-000, (77250)		EA	1							*	*		A8A4MP15H1
P--D		BUTTON, CABLE: 541-5182-002; (13499)		EA	2							*	*		A8A4MP16
P--D	5305-770-2579	SCREW, MACHINE: P330-2292-000, (77250)		EA	1							REF	REF		A8A4MP16H1
P--D		BUTTON, CABLE: 541-5182-002; (13499)		EA	REF							REF	REF		A8A4mP17
P--D	5305-770-2579	SCREW, MACHINE: P330-2292-000; (77250)		EA	1							REF	REF		A8A4MP17H1
P--D	5910-668-3647	CAPACITOR, FIXED, CERAMIC: DA858-003, (71590)		EA	1							*	*	3-64	A8A4C123
P--D	5305-059-8247	SCREW, MACHINE: P343-0327-000; (77250)		EA	1							REF	REF		A8A4C123H1
P--D	5305-059-8248	SCREW, MACHINE: P343-0238-000; (77250)		EA	1							*	*		A8A4C123H2
P--D	5310-939-0903	WASHER, LOCK: 1806-00, (78189)		EA	1							*	*		A8A4C123H3
P--D	5310-184-8978	WASHER, SPRING TENSION: 310-0078-000, (79807)		EA	1							REF	REF		A8A4C123H4
P--D	5910-838-9421	CAPACITOR, FIXED, CERAMIC: CK60AW102M, (81349)		EA	6							*	*		A8A4C20
P--D	5910-838-9421	CAPACITOR, FIXED CERAMIC: CK60AW102M, (81349)		EA	REF							REF	REF		A8A4C21
P--D	5910-838-9421	CAPACITOR, FIXED, CERAMIC: CK60AW102M, (81349)		EA	REF							REF	REF		A8A4C22
P--D	5910-838-9h21	CAPACITOR, FIXED, CERAMIC: CK60AW102M; (81349)		EA	REF							REF	REF		A8A4C23
P--D	5910-838-9421	CAPACITOR, FIXED, CERAMIC: CK60AW102M; (81349)		EA	REF							REF	REF		A8A4C24
P--D	5910-838-9421	CAPACITOR, FIXED, CERAMIC: CK60AW102M, (81349)		EA	REF							REF	REF		A8A4C25
P--D		CAPACITOR, FIXED, CERAMIC: CK14BX223M, (81349)		EA	1							*	*	3-67	A8A4C2
P--D	5910-080-1713	CAPACITOR, FIXED, CERAMIC: DA146, (71590)		EA	1							REF	REF		A8A4C28
P--D	5910-966-9460	CAPACITOR, FIXED, CERAMIC: 243200X5S0102M, (72982)		EA	2							*	*	3-67	A8A4C29
P--D	5310-559-0575	NUT, PLAI, HEXAGON: P334-0254-00, (77250)		EA	1							*	*		A8A4C29H1
P--D	5310-187-0159	WASHER, LOCK: 1218-02, (78189)		EA	1							*	*		A8A4C29H2
P--D	5910-966-9460	CAPACITOR, FIXED, CERAMIC: 243200X5S0102M; (72982)		EA	REF							REF	REF	3-67	A8A4C30

SECTION II

TM 11-5820-509-35

REPAIR PARTS FOR DIRECT SUPPORT, GENERAL SUPPORT, AND DEPOT MAINTENANCE (CONTINUED)															
(1) SMR CODE	(2) FEDERAL STOCK NUMBER	(3) DESCRIPTION Reference Number & Mfr. Code Usable on Code		(4) UNIT OF MEAS	(5) QTY INC IN UNIT	(6) 30 DAY DS MAINTENANCE ALLOWANCE			(7) 30 DAY GS MAINTENANCE ALLOWANCE			(8) 1 YR ALW PER 100 EQUIP CNTGCTY	(9) DEPOT MAINT ALW PER 100 EQUIP	(10) ILLUSTRATION	
						(a) 1-20	(b) 21-50	(c) 51-100	(a) 1-20	(b) 21-50	(c) 51-100			(a) FIG NO.	(b) ITEM NO. OR REFERENCE DESIGNATION
P--D	5310-559-0575	NUT, PLAIN, HEXAGON: P334-0254-00, (77250)		EA	1							REF	REF		A8A4C30H1
P--D	5310-187-0159	WASHER, LOCK: 1218-02, (78189)		EA	1							REF	REF		A8A4C30H2
P--D	5910-162-5179	CAPACITOR, FIXED, ELECTROLYTIC: 610D255F100BD5; (56289)		EA	2							*	*	3-67	A8A,4C26
P--D	5910-162-5179	CAPACITOR, FIXED, ELCTROLYTIC: 610D255F100BD5, (56289)		EA	REF							REF	REF	3-67	A8A4C27
P--D	5910-115-3567	CAPACITOR, FIXED, MICA: CL24BJ180TP3, (81349)		EA	1							*	*		A8A4C145
P--D	5910-951-4822	CAPACITOR, FIXED, MICA: CM60B622J01; (81349)		EA	1							*	*	3-64	A8A4C122
P--D	5305-584-86,24	SCREW, MACHINE: P330-2253-000, (77250)		EA	2							*	*		A8A4C122H1
P--D		SCREW, MACHINE P330-2253-000, (77250)		EA	REF							REF	REF		A8A4C122H2
P--D	5910-889-4562	CAPACITOR, FIXED, PAPER: P109666, (56289)		EA	1							*	*	3-64	A8A4C146
P--D	5310-208-6841	NUT, PLAIN, HEXAGON: P334-0249-00, (77250)		EA	1							*	*		A8A4C146H1
P--D	5310-178-8631	WASHER, LOCK: MS35333-75, (96906)		EA	1							*	*		A8A4C146H2
M--D		CHART, LOAD AND TUNE: 549-6231-004, (13499)		EA	1										A8A4MP18
P--D	5305-150-3079	SCREW, MACHINE: P343-0017-000, (77250)		EA	4							*	*		A8A4MP18H1
P--D		SCREW, MACHINE: P343-0017-000; (77250)		EA	REF							REF	REF		A8A4MP18H2
P--D		SCREW, MACHINE: P343-0017-000, (77250)		EA	REF							REF	REF		A8A4MP18H3
P--D		SCREW, MACHINE: P343-0017-000, (77250)		EA	REF							REF	REF		A8A4MP18H4
M--D		CHASSIS, ELECTRICAL EQUIPMENT: 549-6115-004, (13499)		EA	1										A8A4MP19
P--D	5340-720-6320	CLAMP, LOOP: C3044-1-35, (78553)		EA	1							*	*		A8A4MP20
P--D	5975-72(-)5153	CLAMP, LOOP: MS17821-4-9, (96906)		EA	122							*	*		A8A4MP21
P--D	5821-098-5131	CLAMP, LOOP: 504-7577-002, (13499)		EA	2							REF	REF		A8A4MP22
P--D	5310-276-1101,	NUT, PLAIN, SQUARE: P334-0485-00; (77250)		EA	1							REF	REF		A8A4MP22H1
P--D	5305-637-4225	SCREW, CAP, SOCKET HEAD: B2A440-9C1, (08664)		EA	1							*	*		A8A4MP22H2
P--D	5310-058-2949	WAEKHER, LOCK: 310-0278-000, (70318)		EA	1							REF	REF		A8A4MP22H3
P--D	5821-098-5131	CLAMP, LOOP-TUNER: 504-7577-002, (13499)		EA	REF							REF	REF		A8A4MP23
P--D	5310-276-1104	NUT, PLAIN, SQUARE: P334-0485-00, (77250)		EA	1							REF	RFF		A8A4MP23H1

SECTION II

TM 11-5820-509-35

REPAIR PARTS FOR DIRECT SUPPORT, GENERAL SUPPORT, AND DEPOT MAINTENANCE (CONTINUED)															
(1) SMR CODE	(2) FEDERAL STOCK NUMBER	(3) DESCRIPTION Reference Number & Mfr. Code Usable on Code		(4) UNIT OF MEAS	(5) QTY INC IN UNIT	(6) 30 DAY DS MAINTENANCE ALLOWANCE			(7) 30 DAY GS MAINTENANCE ALLOWANCE			(8) 1 YR ALW PER 100 EQUIP CNTGCTY	(9) DEPOT MAINT ALW PER 100 EQUIP	(10) ILLUSTRATION	
						(a)	(b)	(c)	(a)	(b)	(c)			(a) FIG NO.	(b) ITEM NO. OR REFERENCE DESIGNATION
						1-20	21-50	51-100	1-20	21-50	51-100				
P--D	5305-637-4225	SCREW, CAP, SOCKET HEAD: B2A440-901, (0866)		EA	1							REF	REF		A8A4MP23H2
P--D	5310-05-2949	WASHER, LOCK: 310-0278-000, (70318)		EA	1							REF	REF		A8A4MP23R3
P--D	5950-703-0907	COIL, RADIO FREQUENCY: LT4K048; (81349)		EA	3							*	*	3-67	A8A4L1
P--D	5950-703-0907	COIL, RADIO FREQUENCY: LT4K048, (81349)		EA	REF							REF	REF	3-67	A8A4L2
P--D	5950-703-0907	COIL, RADIO FREQUENCY: LT4K048, (81349)		EA	REF							REF	REF	3-67	A8A4L3
P--D		COIL, RADIO FREQUENCY: MS16221-22, (96906)		EA	1							*	*	3-64	A8A4L105
P--D	5950-988-3060	COIL, RADIO FREQUENCY: BP906; (99800)		EA	1							*	*	3-64	A8A4LI06
P--D	5950-932-2727	COIL, RADIO FREQUENCY: LT10K029, (81349)		EA	2							REF	REF	3-64	A6A4L122
P--D	5950-932-2727	COIL, RADIO FREQUENCY: LT10K029, (81349)		EA	REF							REF	REF	3-64	A8A4L123
P--D	5950-070-7644	COIL., RADIO FREQUENCY: LT10K060, (81349)		EA	2							REF	REF	3-67	A8A4L5
P--D	5950-070-7644	COIL, RADIO FREQUENCY: LT10K060; (81349)		EA	REF							REF	REF	3-67	A8A4L6
P--H-T	5950-978-6204	COIL, RADIO FREQUENCY-NO. 1: 549-6212-003, (13499)		EA	1				*	*	*	*	*	3-64	A8A4L111
P--D	5305-765-4244	SCREW, MACHINE: MS51959-41, (96906)		EA	1							*	*		A8A4L111H1
P--D	5310-889-2614	WASHER, RECESSED: 549-6145-002, (13499)		EA	1							*	*		A8A4L111H2
X1-D		CONTACT, ELECTRICAL-COIL: 549-6153-002, (13499)		EA	2										A8A4L111E1
X1-D		CONTACT, ELECTRICAL-COIL: 549-6153-002, (13499)		EA	REF										A8A4L111E2
X1-D		FORM, COIL: 190-0255-000, (13499)		EA	1										A8A4L111E3
X1-D		GEAR ASSEMBLY, SPUR-NO. 1: 549-6172-002, (13499)		EA	1										A8A4L111MP1
X1-D		GEAR, SPUR-NO. 1A: 549-6158-002, (13499)		EA	1										A8A4L111MP2
X1-D		PIN, SPRING: MS16562-190, (96906)		EA	1										A8A4L111MP3
X1-D		STOP, DIAL-NO. 1: 549-6162-002, (13499)		EA	1										A8A4L111MP4
X1-D		SCREW, MACHINE: MS51959-12, (96906)		EA	1										A8A4L111MP4H1
X1-D		INSULATOR, WASHER: 549-6154-002, (13499)		EA	2										A8A4L111E4
X1-D		INSULATOR, WASHER: 549-6154-002; (13499)		EA	REF										A8A4L111E5
X1-D		LEAD, ELECTRICAL-COIL: 549-6163-002, (13499)		EA	2										ABA4L111E6

REPAIR PARTS FOR DIRECT SUPPORT, GENERAL SUPPORT, AND DEPOT MAINTENANCE (CONTINUED)															
(1) SMR CODE	(2) FEDERAL STOCK NUMBER	(3) DESCRIPTION Reference Number & Mfr. Code Usable on Code		(4) UNIT OF MEAS	(5) QTY INC IN UNIT	(6) 30 DAY DS MAINTENANCE ALLOWANCE			(7) 30 DAY GS MAINTENANCE ALLOWANCE			(8) 1 YR ALW PER 100 EQUIP CNTGCTY	(9) DEPOT MAINT ALW PER 100 EQUIP	(10) ILLUSTRATION	
						(a)	(b)	(c)	(a)	(b)	(c)			(a) FIG NO.	(b) ITEM NO. OR REFERENCE DESIGNATION
						1-20	21-50	51-100	1-20	21-50	51-100				
X1-D		LEAD, ELECTRICAL-COIL: 549-6163-002; (13499)		EA	REF										A8A4L111E7
X1-D		PIN, SPRING, SELF-LOCKING: 99-012-062-0500; (72 962)		EA	1										A8A4L111MP5
X1-D		SHAFT, STRAIGHT-COIL, SHORT: 549-6159-002; (13499)		EA	1										A8A4L111MP6
X1-D		SLEEVE, POWDERED IRON: X8242, (92054)		EA	1										A8A4L111E8
X1-D		WIRE, ELECTRICAL MAGNET: CR14H2277; (99155)		FT	17										A8A4L111W1
P--H-T	5950-978-6205	COIL, RADIO FREQUENCY-NO. 2: 549-6213-003; (13499)		EA	1						*	*	3-64		A8A4L110
X1-D		SCREW, MACHINE: MS51959-41, (96906)		EA	1										A8A4L110H1
X1-D		WASHER, RECESSED: 549-6145-002, (13499)		EA	1										A8A4L110H2
X1-D		CONTACT, ELECTRICAL-COIL: 549-6153-002; (13499)		EA	2										A8A4L110E1
X1-D		CONTACT, ELECTRICAL-COIL: 549-6153-002, (13499)		EA	REF										A8A4L110E2
X1-D		FORM, COIL: 190-0255-000, (13499)		EA	1										A8A4L110E3
X1-D		GEAR, SPUR-NO. 2A: 549-6176-002, (13499)		EA	1										A8A4L110MP1
X1-D		INSULATOR, WASHER: 549-6154-002, (13499)		EA	2										A8A4L110E4
X1-D		INSULATOR, WASHER: 549-6154-002, (13499)		EA	REF										A8A4L110E5
X1-D		LEAD, ELECTRICAL: 549-6163-002; (13499)		EA	2										A8A4L110E6
X1-D		LEAD, ELECTRICAL: 549-6163-002; (13499)		EA	REF										A8A4L110E7
X1-D		PIN, SPRING, SELF-LOCKING: 99-012-062-0500, (72962)		EA	1										A8A4L110MP2
X1-D		SHAFT, STRAIGHT-COIL, SHORT: 549-6159-002; (13499)		EA	1										A8A4L110MP3
X1-D		WIRE, ELECTRICAL: CR14M2277, (99155)		FT	17										A8A4L1110W1
P--H-T	5950-988-3058	COIL, RADIO FREQUENCY-NO. 3: 549-6214-003; (13499)		EA	1						*	*	3-65		A8A4L112
X1-D		CONTACT, ELECTRICAL-COIL: 549-6153-002; (13499)		EA	2										A8A4L112E1
X1-D		CONTACT, ELECTRICAL-COIL: 549-6153-002, (13499)		EA	REF										A8A4L112E2
X1-D		FORM, COIL: 190-0255-000; (13499)		EA	1										A8A4L112E3
X1-D		GEAR, SPUR, 47 TEETH: 549-6175-002, (13499)		EA	1										A8A4L112YP1
X1-D		INSERT, SHAFT-COIL: 549-6178-002, (13499)		EA	1										A8A4L112IP2
X1-D		INSULATOR, WASHER: 549-6154-002, (13499)		EA	2										A8A4L112E4

REPAIR PARTS FOR DIRECT SUPPORT, GENERAL SUPPORT, AND DEPOT MAINTENANCE (CONTINUED)															
(1) SMR CODE	(2) FEDERAL STOCK NUMBER	(3) DESCRIPTION Reference Number & Mfr. Code Usable on Code		(4) UNIT OF MEAS	(5) QTY INC IN UNIT	(6) 30 DAY DS MAINTENANCE ALLOWANCE			(7) 30 DAY GS MAINTENANCE ALLOWANCE			(8) 1 YR ALW PER 100 EQUIP CNTGCTY	(9) DEPOT MAINT ALW PER 100 EQUIP	(10) ILLUSTRATION	
						(a) 1-20	(b) 21-50	(c) 51-100	(a) 1-20	(b) 21-50	(c) 51-100			(a) FIG NO.	(b) ITEM NO. OR REFERENCE DESIGNATION
X1-D		INSULATOR, WASHER: 549-6154-002, (13499)		EA	REF										A8A4112E5
X1-D		LEAD, ELECTRICAL: 549-6163-002, (13499)		EA	2										A8A4L112E6
X1-D		LEAD, ELECTRICAL 519-6163-002; (13499)		EA	REF										A8A4L112E7
X1-D		PIN, SPRING: 99-012-062-0500; (72962)		EA	1										A8A4L112MP3
X1-D		PIN, SPRING, SELF-LOCKING: 99-012-062-0312, (72962)		EA	1										A8A4L112MP4
X1-D		SHAFT, STRAIGHT-COIL, LONG: 549-6160-002, (13499)		EA	1										A8A4L112MP5
X1-D		WIRE, ELECTRICAL: CR14M2277, (99155)		FT	17										A8A4L112W1
P--H-T	5950-988-3059	COIL, RADIO FREQUENCY-TUNING: 549-6215-003, (1399)		EA	1				*	*			3-65		A8A4L109
X1-D		CONTACT, ELECTRICAL: 549-6153-002; (13499)		EA	2										A8A4L109E1
X1-D		CONTACT, ELECTRICAL: 549-6153-002, (13499)		EA	REF										A8A4L109E2
X1-D		FORM, COIL: 190-0255-000; (13499)		EA	1										A8A4L109E3
X1-D		GEAR ASSEMBLY, SPUR-NO. 2: 549-6171-002, (13499)		EA	1										A8A4L109A1
X1-D		GEAR, SPUR-NO. 1, 47 TEETH: 5149-6157-002; (13499)		EA	1										A8A4L109A1MP1
X1-D		PIN, SPRING, TUBULAR SLOTTED: MS16562-190, (96906)		EA	1										A8A4L109A1MP2
X1-D		STOP, DIAL-NO. 1: 549-6162-002; (13499)		EA	1										A8A4L109A1MP3
X1-D		SCREW, MACHINE: A8A4L109A1MP3H1 MS51959-12, (96906)		EA	1										
X1-D		INSERT, SHAFT-COIL: 549-6178-002, (13499)		EA	1										A8A4L109MP4
X1-D		INSULATOR, WASHER: 549-6154-002, (13499)		EA	2										A8A4L109E4
X1-D		INSULATOR, WASHER: 549-6154-002, (13499)		EA	REF										A8A4L109E5
X1-D		LEAD, ELECTRICAL: 549-6163-002; (13199)		EA	2										A8A4L109E6
X1-D		LEAD, ELECTRICAL: 549-6163-002, (13199)		EA	REF										A8A4L109E7
X1-D		PIN, SPRING, SELF-LOCKING: 99-012-062-0312; (7296)		EA	1										A8A4L109MP5
X1-D		PIN, SPRING, SELF-LOCKING: 99-012-062-0500, (72962)		EA	1										A8A4L109MP6
X1-D		SHAFT, STRAIGHT-COIL, LONG: 549-6160-002, (13499)		EA	1										A8A4L109MP7
X1-D		SLEEVE, POWDERED IRON: X8142, (92054)		EA	1										A8A4L109E8

REPAIR PARTS FOR DIRECT SUPPORT, GENERAL SUPPORT, AND DEPOT MAINTENANCE (CONTINUED)															
(1) SMR CODE	(2) FEDERAL STOCK NUMBER	(3) DESCRIPTION Reference Number & Mfr. Code Usable on Code		(4) UNIT OF MEAS	(5) QTY INC IN UNIT	(6) 30 DAY DS MAINTENANCE ALLOWANCE			(7) 30 DAY GS MAINTENANCE ALLOWANCE			(8) 1 YR ALW PER 100 EQUIP CNTGCT	(9) DEPOT MAINT ALW PER 100 EQUIP	(10) ILLUSTRATION	
						(a)	(b)	(c)	(a)	(b)	(c)			(a) FIG NO.	(b) ITEM NO. OR REFERENCE DESIGNATION
						1-20	21-50	51-100	1-20	21-50	51-100				
X1-D		SPACER, PLATE-COIL: 549-6152-002, (13499)		EA	1										A8A4L109MP8
X1-D		WIRE, ELECTRICAL: CR14M2277, (99155)		FT	17										A8A4L109W1
P--D	5950-798-2558	COIL, RADIO FREQUENCY: 553-6325-002, (13499)		EA	1						*	*	3-67	A8A4L4	
M--D		COLLAR, SHAFT: 549-6137-002, (13499)		EA	1										A8A4MP24
P--D	5305-531-0137	SETSCREW: 335-0020-000; (08664)		EA	2						*	*			A8A4MP24H1
P--D	5305-531-0137	SETSCREW: 335-0020-000, (08664)		EA	REF						REF	REF			A8A4MP24H2
P--D	5935-549-2646	CONNECTOR, RECEPTACLE: 164-7J, (02660)		EA	2						*	*			A8A4P2
P--D	5935-549-2646	CONNECTOR, RECEPTACLE: 164-7J, (02660)		EA	REF						REF	REF			A8A4P3
P--D	5935-931-6246	CONNECTOR, RECEPTACLE, ELECTRICAL: DAMF3W3S, (71785)		EA	1						*	*	3-67	A8A4J10	
P--D	5310-622-1721,	NUT, SELF-LOCKING, HEXAGON: 68-1660-26, (72962)		EA	2						REF	REF			A8A4J10H1
P--D	5310-622-1724	NUT, SELF-LOCKING, HEXAGON: 68-1660-26, (72962)		EA	REF						REF	REF			A8A4J10H2
P--D		SCREW, MACHINE: P330-2287-000, (77250)		EA	2						*	*			A3A4J10H3
P--D		SCREW, MACHINE: P330-2287-000, (77250)		EA	REF						REF	REF			A8A4J10H4
M--D	5340-792-1266	SPACER, CHASSIS CONNECTOR-SHORT: 549-6074-002, (13499)		EA	2										A8A4J10H5
M--D	5340-792-1266	SPACER, CHASSIS CONNECTOR-SHORT: 549-6074-002, (13499)		EA	REF										A8A4J10H6
P--D	5935-974-6873	CONNECTOR, RECEPTACLE, ELECTRICAL: DAMF7W2S, (71785)		EA	6						*	*	3-67	A8A4J3	
P--D	5310-622-1724	NUT, SELF-LOCKING, HEXAGON: 68-1660-26; (72962)		EA	2						REF	REF			A8A4J3H1
P--D	5310-622-1724	NUT, SELF-LOCKING, HEXAGON: 68-1660-26, (72962)		EA	REF						REF	REF			A8A4J3H2
P--D		SCREW, MACHINE: P330-2287-000, (77250)		EA	2						REF	REF			A8A4J3H3
P--D		SCREW, MACHINE: P330-2287-000, (77250)		EA	REF						REF	REF			A8A4J3H4
M--D		SPACER, CHASSIS CONNECTOR-LONG: 548-7975-002, (13499)		EA	2										A8A4J3H5
M--D		SPACER, CHASSIS CONNECTOR-LONG: 548-7975-002, (13499)		EA	REF										A8A4J3H6
P--D		CONNECTOR, RECEPTACLE, ELECTRICAL: DAMF7W2S, (71785)		EA	REF						REF	REF			A8A4J6
P--D	5310-622-1724	NUT, SELF-LOCKING, HEXAGON: 68-1660-26, (72962)		EA	2						REF	REF			A8A4J6H1
P--D	5310-622-1724	NUT, SELF-LOCKING, HEXAGON: 68-1660-26; (72962)		EA	REF						REF	REF			A8A4J6H2

REPAIR PARTS FOR DIRECT SUPPORT, GENERAL SUPPORT, AND DEPOT MAINTENANCE (CONTINUED)															
(1) SMR CODE	(2) FEDERAL STOCK NUMBER	(3) DESCRIPTION Reference Number & Mfr. Code Usable on Code		(4) UNIT OF MEAS	(5) QTY INC IN UNIT	(6) 30 DAY DS MAINTENANCE ALLOWANCE			(7) 30 DAY GS MAINTENANCE ALLOWANCE			(8) 1 YR ALW PER 100 EQUIP CNTGCTY	(9) DEPOT MAINT ALW PER 100 EQUIP	(10) ILLUSTRATION	
						(a) 1-20	(b) 21-50	(c) 51-100	(a) 1-20	(b) 21-50	(c) 51-100			(a) FIG NO.	(b) ITEM NO. OR REFERENCE DESIGNATION
P-D	5305-650-7023	SCREW, MACHINE: P330-2287-000; (77250)		EA	2							REF	REF		A8A4J6H3
P-D	5305-850-7023	SCREW, MACHINE: P330-2287-000; (77250)		EA	REF							REF	REF		A8A4J6H4
M-D	5340-792-1266	SPACER, CHASSIS CONNECTOR-SHORT: 549-6074-002, (13499)		EA	2										A8A4J6H5
M-D	5340-792-1266	SPACER, CHASSIS CONNECTOR-SHORT: 549-6074-002, (13499)		EA	REF										ASA4J6H6
P-D		CONNECTOR, RECEPTACLE, ELECTRICAL: DAMF7W2S, (71785)		EA	REF							REF	REF		A8A4J5
P-D	5310-622-1724	NUT, SELF-LOCKING, HEXAGON: 68-1660-26, (72962)		EA	1							REF	REF		ABA4J5HI
P-D	5305-850-7023	SCREW, MACHINE: P330-2287-000, (77250)		EA	2							REF	REF		A8A4JSE2
P-D	5305-850-7023	SCREW, MACHINE: P330-2287-000, (77250)		EA	REF							REF	REF		A8A4J5H3
M-D	5340-792-1266	SPACER, CHASSIS CONNECTOR-SHORT: 549-6074-002; (13499)		EA	2										A8A4J5H4
M-D	5340-792-1266	SPACER, CHASSIS CONNECTOR-SHORT: 549-6074-002; (13499)		EA	REF										A8A4J5H5
P-D	5310-928-2690	WASHER, LOCK, SPRING: MS35338-134, (96906)		EA	1							REF	REF		A8A4J5B6
P-D		CONNECTOR, RECEPTACLE, ELECTRICAL: DAMF7W2S, (71785)		EA	REF							REF	REF	3-67	AsA4J7
P-D	5310-622-1724	NUT, SELF-LOCKING, HEXAGON: 68-1660-26, (72962)		EA	1							REF	REF		A8A4J7H1
P-D	5305-850-7023	SCREW, MACHINE: P330-2287-000, (77250)		EA	2							REF	REF		A8A4J7H2
P-D	5305-850-7023	SCREW, MACHINE: P330-2287-000; (77250)		EA	REF							REF	REF		A8A4J7H3
M-D	5340-792-1266	SPACER, CHASSIS CONNECTOR-SHORT: 549-6074-002; (13499)		EA	2										A8A4J7H4
M-D	5340-792-1266	SPACER, CHASSIS CONNECTOR-SHORT: 549-6074-002; (13499)		EA	REF										A8A4J7H5
P-D	5310-928-2690	WASHER, LOCK, SPRING: MS35338-134, (96906)		EA	1							REF	REF		A8A4J7H6
P-D		CONNECTOR, RECEPTACLE, ELECTRICAL: DAMF7W2S, (71785)		EA	REF							REF	REF	3-67	A8A4J8
P-D	5310-622-1724	NUT, SELF-LOCKING, HEXAGON: 68-1660-26; (72962)		EA	2							REF	REF		A8A4J8H1
P-D	5310-622-1724	NUT, SELF-LOCKING, HEXAGON: 68-1660-26, (72962)		EA	REF							REF	REF		A8A4J8H2
P-D	5305-850-7023	SCREW, MACHINE: P330-2287-000, (77250)		EA	2							REF	REF		A8A4J8H3
P-D	5305-850-7023	SCREW, MACHINE: P330-2287-000, (77253)		EA	REF							REF	REF		A8A4J8Hh
M-D	5340-792-1266	SPACER, CHASSIS CONNECTOR - SHORT: 549-6074-002; (13499)		EA	2										A8A4J8H5
M-D	5340-792-1266	SPACER, CHASSIS CONNECTOR - SHORT: 549-6074-002, (13499)		EA	REF										A8A4J8H6

REPAIR PARTS FOR DIRECT SUPPORT, GENERAL SUPPORT, AND DEPOT MAINTENANCE (CONTINUED)															
(1) SMR CODE	(2) FEDERAL STOCK NUMBER	(3) DESCRIPTION Reference Number & Mfr. Code Usable on Code		(4) UNIT OF MEAS	(5) QTY INC IN UNIT	(6) 30 DAY DS MAINTENANCE ALLOWANCE			(7) 30 DAY GS MAINTENANCE ALLOWANCE			(8) 1 YR ALW PER 100 EQUIP CNTGCT	(9) DEPOT MAINT ALW PER 100 EQUIP	(10) ILLUSTRATION	
						(a)	(b)	(c)	(a)	(b)	(c)			(a) FIG NO.	(b) ITEM NO. OR REFERENCE DESIGNATION
						1-20	21-50	51-100	1-20	21-50	51-100				
P-D		CONNECTOR, RECEPTACLE, ELECTRICAL DAMF7W2S, (71785)		EA	REF							REF	REF	3-67	A8A4J11
P-D	5310-622-1724	NUT, SELF-LOCKING, HEXACGON 68-1660-26, (72962)		EA	2							REF	REF		A8A4J11H1
P-D	5310-622-1724	N1T, SELF-LOCKING, HEXAON 68-1660-26, (72962)		EA	REF							REF	REF		A8A4J11H2
P-D	5305-850-7023	SCREW, MACHINE P330-2287-000, (77250)		EA	2							REF	REF		A8A4J11H3
P-D	5305-850-7023	SCREW, MACHINE P330-2287-000, (77250)		EA	REF							REF	REF		A8A4J11H4
M-D	5340-792-1266	SPACER, CHASSIS CONNECTOR-SHORT 549-6074-002; (13499)		EA	2										A8A4J11H5
M-D	5340-792-1266	SPACER, CHASSIS CONNECTOR-SHORT: 549-6074-002; (13499)		EA	REF										A8A4J11H6
P-D	5935-081-2270	CONNECTOR, RECEPTACLE, ELECTRICAL DBIF13W3S, (71468)		EA	2							*	*	3-67	A8A1J4
P-D	5310-622-1724	NUT, SELF-LOCKING, HEXAGON 68-1660-26, (72962)		EA	2								REF	REF	A8A4J4H1
P-D	5310-622-1724	NUT, SELF-LOCKING, HEXAGON 68-1660-26, (72962)		EA	REF								REF	REF	A8A4J4H2
P-D	5305-850-7023	SCREW, MACHINE P330-2287-000, (77250)		EA	2								REF	REF	A8A4J4H3
P-D	5305-850-7023	SCREW, MACHINE P330-2287-000, (77250)		EA	REF								REF	REF	A8A4J4H4
M-D	SPACER, CHAS	SIS CONNECTOR-LONG 548-7975-002, (13499)		EA	2										ASA4J4H5
M-D	SPACER, CHAS	SIS CONNECTOR-LONG. 518-7975-002, (13499)		EA	REF										A8A4J4H6
P-D	5935-081-2270	CONNECTOR, RECEPTACLE ELECTRICAL DBMF13W3S, (71468)		EA	REF							REF	REF	3-67	A8A4J9
P-D	5310-622-1724	NUT, SELF-LOCKING, HEXAGON- 68-1660-26, (72962)		EA	2								REF	REF	A8A4J9H1
P-D	5310-622-1724	NUT, SELF-LOCKING, HEXAGON 68-1660-26, (72962)		EA	REF								REF	REF	A8A4J9H2
P-D		SCREW, MACHINE. P330-2288-000, (77250)		EA	2								*	*	A8A4J9H3
P-D		SCREW, MACHINE P330-2288-000, (77250)		EA	REF								REF	REF	A8A4J9H4
M-D		SPACER, CHASSIS CONNECTOR-LONG 548-7975-002, (13499)		EA	2										A8A4J9H5
M-D		SPACER, CHASSIS CONNECTOR-T.ONG 548-7975-002, (13499)		EA	REF										A8A4J9H6
P-D	5935-951-7196	CONNECTOR, RECEPTACLE, E1ECTRICAL DCMF27W2S, (71468)		EA	1							*	*	3-67	A8A4J
P-D	5310-622-1724	NUT, SELF-LOCKING, HEXAGON 68-1660-26, (72962)		EA	2								REF	REF	A8A4J1H1
P-D	5310-622-1724	NUT, SELF-LOCKING, HEXAGON. 68-1660-26; (72962)		EA	REF								REF	REF	A8A4J1H2
P-D	5305-850-7023	SCREW, MACHINE. P330-2287-000, (77250)		EA	2								REF	REF	AbA4J1H3

REPAIR PARTS FOR DIRECT SUPPORT, GENERAL SUPPORT, AND DEPOT MAINTENANCE (CONTINUED)															
(1) SMR CODE	(2) FEDERAL STOCK NUMBER	(3) DESCRIPTION Reference Number & Mfr. Code Usable on Code		(4) UNIT OF MEAS	(5) QTY INC IN UNIT	(6) 30 DAY DS MAINTENANCE ALLOWANCE			(7) 30 DAY GS MAINTENANCE ALLOWANCE			(8) 1 YR ALW PER 100 EQUIP CNTGCV	(9) DEPOT MAINT ALW PER 100 EQUIP	(10) ILLUSTRATION	
						(a)	(b)	(c)	(a)	(b)	(c)			(a) FIG NO.	(b) ITEM NO. OR REFERENCE DESIGNATION
						1-20	21-50	51-100	1-20	21-50	51-100				
P--D	5305-850-7023	SCREW, MACHINE: P330-2287-000; (77250)		EA	REF							REF	REF		A8A4J1H4
M--D		SPACER, CHASSIS CONNECTOR-SHORT 549-6074-002, (13499)		EA	2										A8A4J1H5
M--D		SPACER, CHASSIS CONNECTOR-SHORT: 549-6074-002, (13499)		EA	REF										A8A4J1H6
P--D	5935-883-0218	CONNECTOR, RECEPTACLE, ELECTRICAL: DBMF23S, (71468)		EA	1							*	*	3-67	A8A4J2
P--D	5310-622-1724	NUT, SELF-LOCKING, HEXAGON: 68-1660-26; (72962)		EA	2							REF	REF		A8A4J2H1
P--D	5310-622-1724	NUT, SELF-LOCKING, HEXAGON: 68-1660-26, (72962)		EA	REF							REF	REF		A8A4J2H2
P--D	5305-850-7023	SCREW, MACHINE: P330-2287-000; (77250)		EA	2							REF	REF		A8A4J2H3
P--D	5305-850-7023	SCREW, MACHINE: P330-2287-000, (77250)		EA	REF							REF	REF		A8A4J2H4
M--D		SPACER, CHASSIS CONNECTOR-LONG: 548-7975-002, (13499)		EA	2										A8A4J2H5
M--D		SPACER, CHASSIS CONNECTOR-LONG: 548-7975-002, (13499)		EA	REF										A8A4J2H6
P--D	5935-807-8202	CONNECTOR, RECEPTACLE, ELECTRICAL: PT07C18-11P, (77820)		EA	1							*	*		A8A4P1
P--D	5820-984-1799	CONTACT ASSEMBLY, ELECTRICAL: 549-6174-002, (13499)		EA	1							*	*		A8A4E131
P--D		SCREW, MACHINE: P330-2296-000, (77250)		EA	1							REF	REF		A8A4E13111
P--D	5935-773-8947	CONTACT, ELECTRICAL: 548-7911-002, (13499)		EA	2							13	6		A8A4E20
P--D	5935-773-8947	CONTACT, ELECTRICAL: 548-7911-002, (13499)		EA	REF							REF	REF		A8A4E21
P--D	5820-951-4081	CONTACT, ELECTRICAL: 549-6142-002, (13499)		EA	2							*	*		A8A4E22
P--D	5820-951-4081	CONTACT, ELECTRICAL: 549-6142-002, (13499)		EA	REF							REF	REF		A8A4E23
P--D	5820-088-4916	CONTACT, ELECTRICAL: 549-6173-002, (13499)		EA	1							8	3		A8A4E24
P--D		SCREW, MACHINE: P330-2296-000, (77250)		EA	1							REF	REF		A8A4E24H1
P--D	5820-979-0033	CONTACT, ELECTRICAL: 549-6177-002, (13499)		EA	4							*	*		A8A4E25
P--D	5820-979-0033	CONTACT, ELECTRICAL: 549-6177-002, (13499)		EA	REF							REF	REF		A8A4E26
P--D	5820-979-0033	CONTACT, ELECTRICAL: 549-6177-002, (1399)		EA	REF							REF	REF		A8A4E27
P--D	5820-979-0033	CONTACT, ELECTRICAL: 549-6177-002, (13499)		EA	REF							REF	REF		A8A4E28
P--D	5935-733-6655	CONTACT, ELECTRICAL, COAXIAL INSERT: DM53743-5058, (71468)		EA	20							*	*		A8A43A2
P--D	5935-733-6655	CONTACT, ELECTRICAL, COAXIAL INSERT: DM53743-5058, (71460)		EA	REF							REF	REF		A8A4JhA1

REPAIR PARTS FOR DIRECT SUPPORT, GENERAL SUPPORT, AND DEPOT MAINTENANCE (CONTINUED)															
(1) SMR CODE	(2) FEDERAL STOCK NUMBER	(3) DESCRIPTION Reference Number & Mfr. Code Usable on Code		(4) UNIT OF MEAS	(5) QTY INC IN UNIT	(6) 30 DAY DS MAINTENANCE ALLOWANCE			(7) 30 DAY GS MAINTENANCE ALLOWANCE			(8) 1 YR ALW PER 100 EQUIP CNTGCTY	(9) DEPOT MAINT ALW PER 100 EQUIP	(10) ILLUSTRATION	
						(a)	(b)	(c)	(a)	(b)	(c)			(a) FIG NO.	(b) ITEM NO. OR REFERENCE DESIGNATION
						1-20	21-50	51-100	1-20	21-50	51-100				
P--D	5935-733-6655	CONTACT,ELECTRICAL,COAXIAL INSERT DM53743-5058, (71468)		EA	REF							REF	REF	A8A4J4A2	
P--D	5935-733-6655	CONTACT,ELECTRICAL,COAXIAL INSERT DM53743-5058; (71468)		EA	REF							REF	REF	A8A4J4A3	
P--D	5935-733-6655	CONTACT,ELECTRICAL,COAXIAL INSERT DM53743-5058, (71468)		EA	REF							REF	REF	A8A4J5A1	
P--D	5935-733-6655	CONTACT,ELECTRICAL,COAXIAL INSERT DM5374-3-5058, (71468)		EA	REF							REF	REF	A8A4J5A2	
P--D	5935-733-6655	CONTACT,ELECTRICAL,COAXIAL INSERT DM53743-5058, (71468)		EA	REF							REF	REF	A8A4J6A	
P--D	5935-733-6655	CONTACT,ELECTRICAL,COAXIAL INSERT DM53743-5058, (71468)		EA	REF							REF	REF	A8A4J7A1	
P--D	5935-733-6655	CONTACT, ELECTRICAL, COAXIAL ISERT DM53743-5058, (71468)		EA	REF							REF	REF	A8A4J7A2	
P--D	5935-733-6655	CONTACT,ELECTRICAL,COAXIAL INSERT DM53743-5058, (71468)		EA	REF							REF	REF	A8A4J8A1	
P--D	5935-733-6655	CONTACT,ELECTRICAL,COAXIAL INSERT DM53743-5058, (71468)		EA	REF							REF	REF	A8A4J8A2	
P--D	5935-733-6655	CONTACT,ELECTRICAL,COAXIAL INSERT DM53743-5058, (71468)		EA	REF							REF	REF	A8A4J9A1	
P--D	5935-733-6655	CONTACT,ELECTRICAL,COAXIAL INSERT DM53743-5058, (71468)		EA	REF							REF	REF	A8A4J9A2	
P--D	5935-733-6655	CONTACT,ELECTRICAL,COAXIAL INSERT DM53743-5058, (71468)		EA	REF							REF	REF	A8A4J9A3	
P--D	5935-733-6655	CONTACT,ELECTRICAL,COAXIAL INSERT DM53743-5058, (71468)		EA	REF							REF	REF	A8A4J10A1	
P--D	5935-733-6655	CONTACT,ELECTRICAL,COAXIAL INSERT DM53743-5058, (71468)		EA	REF							REF	REF	A8A4J10A2	
P--D	5935-733-6655	CONTACT,ELECTRICAL,COAXIAL INSERT DM53743-5058, (71468)		EA	REF							REF	REF	A8A4J10A3	
P--D	5935-733-6655	CONTACT,ELECTRICAL,COAXIAL INSERT DM53743-5058, (71468)		EA	REF							REF	REF	A8A4J11A2	
P--D	5820-088-4916	CONTACT, ELECTRICAL, ROD: 549-6164-002, (13499)		EA	4							*	*	A8A4E29	
P--D		SCREW, MACHINE: P320-0007-000, (77250)		EA	2							*	*	A8A4E29H1	
P--D		SCREW, MACHINE: P320-0007-000, (77250)		EA	REF							REF	REF	A8A4E29H2	
P--D	5310-925-7991	WASHER, LOCK: 310-0274-000, (13499)		EA	2							*	*	A8A4E29H3	
P--D	5310-925-T991	WASHER, LOCK: 310-0274-000, (13499)		EA	REF							REF	REF	A8A4E29H4	
P--D	5820-088-4916	CONTACT, ELECTRICAL, ROD: 549-6164-002, (13499)		EA	REF							REF	REF	A8A4E30	
P--D		SCREW, MA.CHINE: P320-0007-000, (77250)		EA	2							REF	REF	A8ALE300H	

SECTION II

TM 11-5820-509-35

REPAIR PARTS FOR DIRECT SUPPORT, GENERAL SUPPORT, AND DEPOT MAINTENANCE (Continued)															
(1) SMR CODE	(2) FEDERAL STOCK NUMBER	(3) DESCRIPTION Reference Number & Mfr. Code Usable on Code		(4) UNIT OF MEAS	(5) QTY INC IN UNIT	(6) 30 DAY DS MAINTENANCE ALLOWANCE			(7) 30 DAY GS MAINTENANCE ALLOWANCE			(8) 1 YR ALW PER 100 EQUIP CNTGCTY	(9) DEPOT MAINT ALW PER 100 EQUIP	(10) ILLUSTRATION	
						(a) 1-20	(b) 21-50	(c) 51-100	(a) 1-20	(b) 21-50	(c) 51-100			(a) FIG NO.	(b) ITEM NO. OR REFERENCE DESIGNATION
P-D	5305-680-5561	SCREW, MACHINE: P320-0007-000; (77250)		EA	REF							REF	REF		A8A4E30H2
P-D	5310-925-7991	WASHER, LOCK: 310-0274-000; (13499)		EA	2							REF	REF		A8A4E30H3
P-D	5310-925-7991	WASHER, LOCK: 310-0274-000; (13499)		EA	REF							REF	REF		A8A4E30H4
P-D	5820-088-4916	CONTACT, ELECTRICAL, ROD: 549-6164-002; (13499)		EA	REF							REF	REF		A8A4E31
P-D	5305-680-5561	SCREW, MACHINE: P320-0007-000; (77250)		EA	2							REF	REF		A8A4E31H1
P-D	5305-680-5561	SCREW, MACHINE: P320-0007-000; (77250)		EA	REF							REF	REF		A8A4E31H2
P-D	5310-925-7991	WASHER, LOCK: 310-0274-000; (13499)		EA	2							REF	REF		A8A4R31H3
P-D	5310-925-7991	WASHER, LOCK: 310-0274-000; (13499)		EA	REF							REF	REF		A8A4E31H4
P-D	5820-088-4916	CONTACT, ELECTRICAL, ROD: 549-6164-002; (13499)		EA	REF							REF	REF		A8A4E32
P-D	5305-680-556 1	SCREW, MACHINE: P320-007-000; (77250)		EA	2							REF	REF		A8A4E32H1
P-D	5305-630-5561	SCREW, MACHINE: P320-0007-000; (77250)		EA	REF							REF	REF		A8A4E32H2
P-D	5310-925-7991	WASHER, LOCK: 310 -0274-000; (13499)		EA	2							REF	REF		A8A4E32H3
P-D	5310-925-7991	WASHER, LOCK: 310-0274-000; (13499)		EA	REF							REF	REF		A8A4E32H4
P-D	5950-809-9357	COUPLER, METER ASSEMBLY: 772-8458-001; (13499)		EA	1							*	*	3-64	A8A4T101
P-D	5305-054-5648	SCREW, MACHINE: MS51957-14; (96906)		EA	2							REF	REF		A8A4T101H1
P-D	5305-054-5648	SCREW, MACHINE: MS5L957-14; (96906)		EA	REF							REF	REF		A8A4T101H2
P-D	5310-782-1349	WASHER, FLAT: 31-0045-000; (79807)		EA	2							REF	REF		A8A4T101H3
P-D	5310-782-1349	WASHER, FLAT: 310-0045-000; (79807)		EA	REF							REF	REF		A8A4T101H14
M-D		COVER, CHASSIS BOTTOM: 756-8606-003; (13499)		EA	1										A8A4MP25
P-D	5305-054-5647	SCREW, MACHINE: MS51957-13; (96906)		EA	11							REF	REF		A8A4MP25H1
P-D	5305-054-5647	SCREW, MACHINE: MS51957-13; (96906)		EA	REF							REF	REF		A8A4MP25H2
P-D	5305-054-5647	SCREW, MACHINE: MS51957-13; (96906)		EA	REF							REF	REF		A8A4MP25H3
P-D	5305-054-5647	SCREW, MACHINE: MS51957-13; (96906)		EA	REF							REF	REF		A8A4MP25H4
P-D	5315-054-5647	SCREW, MACHINE: MS51957-13; (96906)		EA	REF							REF	REF		A8A4MP25H5
P-D	5305-054-5647	SCREW, MACHINE: MS5195 -13; (96906)		EA	REF							REF	REF		A8A4MP25H6

SECTION II

TM 11-5820-509-35

REPAIR PARTS FOR DIRECT SUPPORT, GENERAL SUPPORT, AND DEPOT MAINTENANCE (Continued)															
(1) SMR CODE	(2) FEDERAL STOCK NUMBER	(3) DESCRIPTION Reference Number & Mfr. Code Usable on Code		(4) UNIT OF MEAS	(5) QTY INC IN UNIT	(6) 30 DAY DS MAINTENANCE ALLOWANCE			(7) 30 DAY GS MAINTENANCE ALLOWANCE			(8) 1 YR ALW PER 100 EQUIP CNTGCTY	(9) DEPOT MAINT ALW PER 100 EQUIP	(10) ILLUSTRATION	
						(a)	(b)	(c)	(a)	(b)	(c)			(a) FIG NO.	(b) ITEM NO. OR REFERENCE DESIGNATION
						1-20	21-50	51-100	1-20	21-50	51-100				
P-D	5305-054-5647	SCREW, MACHINE: MS51957-13; (9690 6)		EA	REF							REF	REF	A8A4MP25H7	
P-D	5305-054-5647	SCREW, MACHINE: MS51957-13; (96906)		EA	REF							REF	REF	A8A4MP25H8	
P-D	5305-054-5647	SCREW, MACHINE: MS51957-13; (96906)		EA	REF							REF	REF	A8A4MP25H9	
P-D	5305-054-5647	SCREW, MACHINE: MS51957-13; (96906)		EA	REF							REF	REF	A8A4MP25H10	
P-D	5305-054-5647	SCREW, MACHINE: MS51957-13; (96906)		EA	REF							REF	REF	A8A4MP25H11	
M-D		COVER, CHASSIS TOP: 549-6109-003; (13499)		EA	1									A8A4MP26	
P-D	5305-054-5647	SCREW, MACHINE: MS51957-13; (96906)		EA	11							REF	REF	A8A4MP26H1	
P-D	5305-054-5647	SCREW, MACHINE: MS51957-13; (96906)		EA	REF							REF	REF	A8A4MP26H2	
P-D	5305-054-5647	SCREW, MACHINE: MS51957-13; (96906)		EA	REF							REF	REF	A8A4MP26H3	
P-D	5305-054-5647	SCREW, MACHINE: MS51957-13; (96906)		EA	REF							REF	REF	A8A4MP26H4	
P-D	5305-054-5647	SCREW, MACHINE: MS51957-13; (96906)		EA	REF							REF	REF	A8A4MP26H5	
P-D	5305-054-5647	SCREW, MACHINE: MS51957-13; (96906)		EA	REF							REF	REF	A8A4MP26H6	
P-D	5305-054-5647	SCREW, MACHINE: MS51957-13; (96906)		EA	REF							REF	REF	A8A4MP26H7	
P-D	5305-054-5647	SCREW, MACHINE: MS51957-13; (96906)		EA	REF							REF	REF	A8A4MP26H8	
P-D	5305-054-5647	SCREW, MACHINE: MS51957-13; (96906)		EA	REF							REF	REF	A8A4MP26H9	
P-D	5305-054-5647	SCREW, MACHINE: MS51957-13; (96906)		EA	REF							REF	REF	A8A4HP26H10	
P-D	5305-054-5647	SCREW, MACHINE: MS51957-13; (96906)		EA	REF							REF	REF	A8A4MP26H11	
M-D		COVER, HEATSINK: 549-6155-002; (13499)		EA	1									A8A4MP27	
P-D	5305-764-0068	SCREW, MACHINE: MS35200-A2; (96906)		EA	4							*	*	A8A4MP27H1	
P-D	5305-764-0068	SCREW, MACHINE: MS35200-42; (96906)		EA	REF							REF	REF	A8A4MP27H2	
P-D	5305-764-0068	SCREW, MACHINE: MS35200-42; (96906)		EA	REF							REF	REF	A8A4MP27H3	
P-D	5305-764-0068	SCREW, MACHINE: MS35200-h2; (96906)		EA	REF							REF	REF	A8A4MP27H4	
M-D		DIAL, VERNIER-MODIFIED: 756-7565-002; (13499)		EA	2									A8A4A3	
M-D	5355-949-9341	DIAL, SCALE: SR166; (73138)		EA	1									A8A4A3MP1	
P-D		SETSCREW: 328-0014-000; (08664)		EA	2							*	*	A8A4A3MPH1	

SECTION II

TM 11-5820-509-35

REPAIR PARTS FOR DIRECT SUPPORT, GENERAL SUPPORT, AND DEPOT MAINTENANCE (Continued)															
(1) SMR CODE	(2) FEDERAL STOCK NUMBER	(3) DESCRIPTION Reference Number & Mfr. Code Usable on Code		(4) UNIT OF MEAS	(5) QTY INC IN UNIT	(6) 30 DAY DS MAINTENANCE ALLOWANCE			(7) 30 DAY GS MAINTENANCE ALLOWANCE			(8) 1 YR ALW PER 100 EQUIP CNTGCTY	(9) DEPOT MAINT ALW PER 100 EQUIP	(10) ILLUSTRATION	
						(a)	(b)	(c)	(a)	(b)	(c)			(a) FIG NO.	(b) ITEM NO. OR REFERENCE DESIGNATION
						1-20	21-50	51-100	1-20	21-50	51-100				
M-D		DIAL, VERNIER-MODIFIED: 756-7565-002; (13499)		EA	REF										A8A4A4
M-D		DIAL, SCALE: SR166; (73138)		EA	REF										A8A4A4MP1
P-D	5305-206-9458	SETSCREW: 328-0014-000; (08664)		EA	REF						REF	REF			A8A4A4M1H1
P-H-T	5915-904-7529	FILTER, RADIO INTERFERENCE: 553-6330-004; (13499)		EA	1				*	*	*	*	*	3-67	A8A4FL2
P-D		NUT, PLAIN, HEXAGON: P313-0132-000; (77250)		EA	2						REF	REF			A8A4FL2H2
P-D	5305-763-7822	SCREW, MACHINE: P330-2291-000; (77250)		EA	2						*	*			A8A4FL2H2
P-D	5310-782-1349	WASHER, FLAT: 310-0045-000; (79807)		EA	4						REF	REF			A8A4FL2H4
P-D	5330-058-2949	WASHER, LOCK: 310-0278-000; (70318)		EA	2						REF	REF			A8A4FL2H2
X1-D		CAPACITOR, FIXED, CERAMIC: 41092; (01939)		EA	3										A8A4FL2C231
X1-D		CAPACITOR, FIXED, CERAMIC: 41092; (01939)		EA	REF										A8A4FL2C232
X1-D		CAPACITOR, FIXED, CERA11C: 41092; (01939)		EA	REF										A8A4FL2C233
X1-D		CAPACITOR, FIXED, CERAMIC: 2465-009W5T0102P; (72982)		EA	26										A8A4FL2C201
X1-D		CAPACITOR, FIXED, CERAMIC: 2465-009W5T0102P; (72982)		EA	REF										A8A4FL2C202
X1-D		CAPACITOR, FIXED, CERAMIC: 2465-009W5T0102P; (72982)		EA	REF										A8A4FL2C203
X1-D		CAPACITOR, FIXED, CERAMIC: 2465-009W5T0102P; (72982)		EA	REF										A8A4FL2C204
X1-D		CAPACITOR, FIXED, CERAMIC: 2465-009W5T0102P; (72982)		EA	REF										A8A4FL2C205
X1-D		CAPACITOR, FIXED, CERAMIC: 2465-009W5T0102P; (72982)		EA	REF										A8A4FL2C206
X1-D		CAPACITOR, FIXED, CERAMIC: 2465-009W5T0102P; (72982)		EA	REF										A8A4FL2C207
X1-D		CAPACITOR, FIXED, CERAMIC: 2465-009W5T0102P; (72982)		EA	REF										A8A4FL2C208
X1-D		CAPACITOR, FIXED, CERAMIC: 2465-009W5T0102P; (72982)		EA	REF										A8A4FL2C209
X1-D		CAPACITOR, FIXED, CERAMIC: 2465-009W5T0102P; (72982)		EA	REF										A8A4FL2C210
X1-D		CAPACITOR, FIXED, CERAMIC: 2465-009W5T0102P; (72982)		EA	REF										A8A4FL2C211
X1-D		CAPACITOR, FIXED, CERAMIC: 2465-009W5T0102P; (729 82)		EA	REF										A8A4FL2C212
X1-D		CAPACITOR, FIXED, CERAMIC: 2465-009W5T0102P; (72982)		EA	REF										A8A4FL2C213
X1-D		CAPACITOR, FIXED, CERAMIC: 2465-009W5T0102P; (72982)		EA	REF										A8A4FL2C214

SECTION II

TM 11-5820-509-35

REPAIR PARTS FOR DIRECT SUPPORT, GENERAL SUPPORT, AND DEPOT MAINTENANCE (Continued)															
(1) SMR CODE	(2) FEDERAL STOCK NUMBER	(3) DESCRIPTION Reference Number & Mfr. Code Usable on Code		(4) UNIT OF MEAS	(5) QTY INC IN UNIT	(6) 30 DAY DS MAINTENANCE ALLOWANCE			(7) 30 DAY GS MAINTENANCE ALLOWANCE			(8) 1 YR ALW PER 100 EQUIP CNTGCTY	(9) DEPOT MAINT ALW PER 100 EQUIP	(10) ILLUSTRATION	
						(a)	(b)	(c)	(a)	(b)	(c)			(a) FIG NO.	(b) ITEM NO. OR REFERENCE DESIGNATION
						1-20	21-50	51-100	1-20	21-50	51-100				
X1-D		CAPACITOR, FIXED, CERAMIC: 2465-009W5T0102P; (72982)		EA	REF										A8A4FL2C215
X1-D		CAPACITOR, FIXED, CERAMIC: 2465-009W5T0102P; (72982)		EA	REF										A8A4FL2C216
X1-D		CAPACITOR, FIXED, CERAMIC: 2465-009W5T0102P; (72982)		EA	REF										A8A4FL2C217
X1-D		CAPACITOR, FIXED, CERAMIC: 2465-009W5T0102P; (72982)		EA	REF										A8A4FL2C218
X1-D		CAPACITOR, FIXED, CERAMIC: 2465-009W5T0102P; (72982)		EA	REF										A8A4FL2C219
X1-D		CAPACITOR, FIXED, CERAMIC: 2465-009W5T0102P; (72982)		EA	REF										A8A4FL2C220
X1-D		CAPACITOR, FIXED, CERAMIC: 2465-009W5T0102P; (72982)		EA	REF										A8A4FL2C221
X1-D		CAPACITOR, FIXED, CERAMIC: 2465-009W5T0102P; (72982)		EA	REF										A8A4FL2C222
X1-D		CAPACITOR, FIXED, CERAMIC: 2465-009W5T0102P; (72982)		EA	REF										A8A4FL2C223
X1-D		CAPACITOR, FIXED, CERAMIC: 2465-009W5T0102P; (72982)		EA	REF										A8A4FL2C224
X1-D		CAPACITOR, FIXED, CERAMIC: 2465-009W5T0102P; (72982)		EA	REF										A8A4FL2C225
X1-D		CAPACITOR, FIXED, CERAMIC: 2465-009W5T0102P; (72982)		EA	REF										A8A4FL2C226
X1-D		CAPACITOR, FIXED, CERAMIC: CK104; (71590)		EA	REF										A8A4FL2C227
X1-D		CAPACITOR, FIXED, CERAMIC: CK104; (71590)		EA	REF										A8A4FL2C229
X1-D		CAPACITOR, FIXED, CERAMIC: CK104; (71590)		EA	REF										A8A4FL2C230
X1-D		CAPACITOR, FIXED, CERAMIC: CK104; (71590)		EA	REF										A8A4FL2C234
X1-D		CAPACITOR, FIXED, CERAMIC: CK104; (71590)		EA	REF										A8A4FL2C235
X1-D		CAPACITOR, FIXED, CERAMIC: CK104; (71590)		EA	REF										A8A4FL2C237
X1-D		CAPACITOR, FIXED, ELECTROLYTIC: 610D25F100BD5; (56289)		EA	REF										A8A4FL2C236
X1-D		COIL, RADIO FREQUENCY: 4422-11-117; (82142)		EA	REF										A8ALFL2C206
X1-D		COIL, RADIO FREQUENCY: LT10K043; (81349)		EA	REF										A8A4FL2L201
X1-D		COIL, RADIO FREQUENCY: LT10K043; (81349)		EA	REF										A8A4FL2L202
X1-D		COIL, RADIO FREQUENCY: LT10K043; (81349)		EA	REF										A8A4FL2L203
X1-D		COIL, RADIO FREQUENCY: LT10K043; (81349)		EA	REF										A8A4FL2L204
X1-D		COIL, RADIO FREQUENCY: LT10K043; (81349)		EA	REF										A8A4FL2L205

SECTION II

TM 11-5820-509-35

REPAIR PARTS FOR DIRECT SUPPORT, GENERAL SUPPORT, AND DEPOT MAINTENANCE (Continued)															
(1) SMR CODE	(2) FEDERAL STOCK NUMBER	(3) DESCRIPTION Reference Number & Mfr. Code Usable on Code		(4) UNIT OF MEAS	(5) QTY INC IN UNIT	(6) 30 DAY DS MAINTENANCE ALLOWANCE			(7) 30 DAY GS MAINTENANCE ALLOWANCE			(8) 1 YR ALW PER 100 EQUIP CNTGCTY	(9) DEPOT MAINT ALW PER 100 EQUIP	(10) ILLUSTRATION	
						(a) 1-20	(b) 21-50	(c) 51-100	(a) 1-20	(b) 21-50	(c) 51-100			(a) FIG NO.	(b) ITEM NO. OR REFERENCE DESIGNATION
X1-D		COIL, RADIO FREQUENCY: LT10K43; (81349)		EA	REF										A8A4FL2L207
X1-D		COIL, RADIO FREQUENCY: LT10K43; (81349)		EA	REF										A8A4FL2L208
X1-D		COIL, RADIO FREQUENCY: LT10K43; (81349)		EA	REF										A8A4FL2L209
X1-D		COIL, RADIO FREQUENCY: LT10K43; (81349)		EA	REF										A8A4FL2L210
X1-D		COIL, RADIO FREQUENCY: LT10K43; (81349)		EA	REF										A8AL4L2L211
X1-D		COVER, SHIELD: 553-6279-002; (13499)		EA	1										AA4 FL2E1
X1-D		SCREW, MACHINE: P343-0298-000; (77250)		EA	6										A8A4FL2E1H1
X1-D		SCREW, MACHINE: P343-0298-000; (77250)		EA	REF										A8A4FL2E1H2
X1-D		SCREW, MACHINE: P343-0298-000; (77250)		EA	REF										A8A4FL2E1H3
X1-D		SCREW, MACHINE: P343-0298-000; (77250)		EA	REF										A8A4FL2E1H4
X1-D		SCREW, MACHINE: P343-0298-000; (77250)		EA	REF										A8A4FL2E1H5
X1-D		SCREW, MACHINE: P343-0298-000; (77250)		EA	REF										A8A4FL2E1H6
X1-D		WASHER, LOCK: MS35338-96; (96906)		EA	6										A8A4FL2E1H7
X1-D		WASHER, LOCK: MS35338-96; (96906)		EA	REF										A8A4FL2E1H8
X1-D		WASHER, LOCK: MS35338-96; (96906)		EA	REF										A8A4FL2E1H9
X1-D		WASHER, LOCK: MM35338-96; (96906)		EA	REF										A8A4FL2E1H10
X1-D		WASHER, LOCK: MM35338-96; (96906)		EA	REF										A8A4FL2E1H11
X1-D		WASHER, LOCK: MS35338-96; (96906)		EA	REF										A8A4FL2E1H12
X1-D		RING, SOLDER: 054-0368-000; (13499)		EA	V										A8A4FL2MP1
X1-D		SHIELD, FILTER-ROLLED: 553-6300-004; (13499)		EA	1										A8A4FL2E2
P-O	5920-280-3562	FUSE, CARTRIDGE: F03A125V20AS; (81349)		EA	1										8A4F1
P-O	5920-356-2185	FUSE, CARTRIDGE: MDL1-10; (71400)		EA	1	*	*	*	*	*	*	*	*	3-67	A8A4F5
P-O	5920-481-1418	FUSE, CARTRIDGE: AGC250-1-500; (71400)		EA	1	*	*	*	*	*	*	*	*	3-67	A8A4F4
P-O	5920-280-8344	FUSE, CARTRIDGE: FO2A250V1-2AS; (81349)		EA	1	*	*	*	*	*	*	*	*	3-67	A8A4F3
P-O	5920-060-2424	FUSE, CARTRIDGE: FO2A250V54S; (81349)		EA	1	*	*	*	*	*	*	*	*		A8A4F2

SECTION II

TM 11-5820-509-35

REPAIR PARTS FOR DIRECT SUPPORT, GENERAL SUPPORT, AND DEPOT MAINTENANCE (Continued)															
(1) SMR CODE	(2) FEDERAL STOCK NUMBER	(3) DESCRIPTION Reference Number & Mfr. Code Usable on Code		(4) UNIT OF MEAS	(5) QTY INC IN UNIT	(6) 30 DAY DS MAINTENANCE ALLOWANCE			(7) 30 DAY GS MAINTENANCE ALLOWANCE			(8) 1 YR ALW PER 100 EQUIP CNTGCTY	(9) DEPOT MAINT ALW PER 100 EQUIP	(10) ILLUSTRATION	
						(a) 1-20	(b) 21-50	(c) 51-100	(a) 1-20	(b) 21-50	(c) 51-100			(a) FIG NO.	(b) ITEM NO. OR REFERENCE DESIGNATION
P-D	5920-728-3487	FUSEHOLDER: 340149; (75915)		EA	2							*	*		A8A4XF1
P-D	5920-728-3487	FUSEHOLDER: 340149; (75915)		EA	REF							REF	REF		A8A4XF2
P-D		FUSEHOLDER-RIVETED: 553-9750-003; (13499)		EA	1							*	*	3-67	A8A4TB8
P-D		SCREW, MACHINE: P330-2290-000; (77250)		EA	2							REF	REF		A8A4TB8H1
P-D		SCREW, MACHINE: P330-2290-000; (77250)		EA	REF							REF	REF		A8A4TB8H2
P-D	5920-168-1402	FUSEHOLDER-RIVETED: 553-9750-004; (13499)		EA	1							*	*	3-67	A8A4TB9
P-D		SCREW, MACHINE: P330-2290-000; (77250)		EA	2							REF	REF		A8A4TB9H1
P-D		SCREW, MACHINE: P330-2290-000; (77250)		EA	REF							REF	REF		A8A4TB9H2
P-D		FUSEHOLDER, RIVETED: 553-9750-005; (13499)		EA	1							*	*	3-67	A8A4TB10
P-D		SCREW, MACHINE: P330-2290-000; (77250)		EA	2							REF	REF		A8A4TB10H1
P-D		SCREW, MACHINE: P330-2290-000; (77250)		EA	REF							REF	REF		A8A4TB10H2
M-D		GASKET: ARP567-009; (83259)		EA	2										A8A4MP28
M-D		GASKET: ARP567-009; (83259)		EA	REF										A8A4MP29
M-D		GASKET: 549-6136-002; (13499)		EA	1										A8A4MP30
M-D		GASKET, AIR: 549-6644-002; (13499)		EA	1										A8A4MP31
M-D	5330-981-7538	GASKET, HEATSINK: 549-6156-002; (13499)		EA	2										A8A4MP32
M-D	5330-981-7538	GASKET, HEATSINK: 549-6156-00 2; (13499)		EA	REF										ABA4MP33
M-D		GASKET, METER: 549-6185-002; (13499)		EA	1										A8A4MP34
P-D	3020-976-5393	GEAR ASSEMBLY, SPUR: 549-6105-002; (13499)		EA	1							*	*		A8A4A5
X1-D		GEAR, SPUR, 46 TEETH, NO 2: 549-6093-002; (13499)		EA	1										A8A4A5MP1
X1-D		PIN, SPRING, SELF-LOCKING: MS16562-190; (96906)		EA	1										A8A4A5MP2
X1-D		STOP, DIAL, NO 2: 549-6094-002; (13499)		EA	1										A8A4A5MP3
X1-D		SCREW, MACHINE: MS51959-12; (96906)		EA	1										A8A4A5MP3H1
P-D	3020-951-0700	GEAR, SPUR-90 TEETH 549-6196-002; (13499)		EA	1										A8A4MP35
P-D	5310-158-5247	WASHER: 506-5908-003; (13499)		EA	1							*	*		A8A4MP35H1

SECTION II

TM 11-5820-509-35

REPAIR PARTS FOR DIRECT SUPPORT, GENERAL SUPPORT, AND DEPOT MAINTENANCE (Continued)															
(1) SMR CODE	(2) FEDERAL STOCK NUMBER	(3) DESCRIPTION Reference Number & Mfr. Code Usable on Code		(4) UNIT OF MEAS	(5) QTY INC IN UNIT	(6) 30 DAY DS MAINTENANCE ALLOWANCE			(7) 30 DAY GS MAINTENANCE ALLOWANCE			(8) 1 YR ALW PER 100 EQUIP CNTGCTY	(9) DEPOT MAINT ALW PER 100 EQUIP	(10) ILLUSTRATION	
						(a)	(b)	(c)	(a)	(b)	(c)			(a) FIG NO.	(b) ITEM NO. OR REFERENCE DESIGNATION
						1-20	21-50	51-100	1-20	21-50	51-100				
P-D	5325-174-5317	GROMMET, RUBBER: MS35489-4; (96906)		EA	1							REF	REF	A8A4H1	
P-D	5325-286-6047	GROMMET, RUBBER: MS35489-1; (96906)		EA	2							REF	REF	A8A4H2	
P-D	5325-286-6047	GROMMET, RUBBER: MS35489-1; (96906)		EA	REF							REF	REF	A8A4H3	
P-D	5325-276-4993	GROMMET, RUBBER: 905; (75543)		EA	2							REF	REF	A8A4H4	
P-D	5325-276-4993	GROMMET, RUBBER: 905; (75543)		EA	REF							REF	REF	A8A4H5	
P-D	5325-248-7031	GROMMET, RUBBER: 911; (75543)		EA	1							*	*	A8A4H6	
M-D		HARNESS, WIRING, BRANCHED: 549-6227-000; (13499)		EA	1									3-67 A8A4W1	
P-D	5820-168-1583	HEATSINK, ELECTRON TUBE: 549-6211-003; (13499)		EA	1							*	*	A8A4E33	
P-D	5820-979-0034	HOLDER, RESISTOR: 549-6129-002; (13499)		EA	1							*	*	A8A4MP36	
P-D	5310-262-6105	NUT, PLAIN, HEXAGON: P313-0045-000; (77250)		EA	2							REF	REF	A8A4MP36H1	
P-D	5310-262-6105	NUT, PLAIN, HEXAGON: P313-0045-000; (77250)		EA	REF							REF	REF	A8A4MP36H2	
P-D	5305-054-6650	SCREW, MACHINE: MS51957-26; (96906)		EA	2							*	*	A8A4MP36H3	
P-D	5305-054-6650	SCREW, MACHINE: MS51957-26; (96906)		EA	REF							REF	REF	A8A4MP36H4	
P-D	5310-271-7446	WASHER, LOCK, SPLIT: 310-0071-000; (79807)		EA	2							REF	REF	A8A4MP36H5	
P-D	5310-271-7446	WASHER, LOCK, SPLIT: 310-0071-000; (79807)		EA	REF							REF	REF	A8A4MP36H1	
P-D	5935-977-6239	INSERT, ELECTRICAL CONNECTOR: DM51155-5000; (71468)		EA	2							*	*	A8A4J1A1	
P-D	5935-977-6239	INSERT, ELECTRICAL CONNECTOR: DM51155-5000; (71468)		EA	REF							REF	REF	A8A4J1A2	
P-D	5960-984-0422	INSERT, ELECTRON TUBE SHIELD: 106-331-4; (99378)		EA	1							*	*	A8A4MP37	
P-D	6250-431-3743	INSERT, LAMPHOLDER: 548-7910-002; (13499)		EA	2							*	*	A8A4MF38	
P-D		INSERT, LAMPHOLDER: 548-7910-002; (13499)		EA	REF							REF	REF	A8A4MP39	
P-D	5820-977-6238	INSERT, LAMPHOLDER: 549-6143-002; (13499)		EA	2							*	*	A8A4MP40	
P-D	5820-977-6238	INSERT, LAMPHOLDER: 549-6143-002; (13499)		EA	REF							REF	REF	A8A4MP41	
P-D	5355-950-7575	KNOB-LARGE: 549-6189-002; (13499)		EA	1							*	*	A8A4MP42	
P-D	5305-531-0137	SETSCREW: 335-0020-000; (08664)		EA	2							REF	REF	A8A4MP42H1	
P-D	5305-531-0137	SETSCREW: 335-0020-000; (08664)		EA	REF							REF	REF	A8A4MP42H2	

SECTION II

TM 11-5820-509-35

REPAIR PARTS FOR DIRECT SUPPORT, GENERAL SUPPORT, AND DEPOT MAINTENANCE (Continued)															
(1) SMR CODE	(2) FEDERAL STOCK NUMBER	(3) DESCRIPTION Reference Number & Mfr. Code Usable on Code		(4) UNIT OF MEAS	(5) QTY INC IN UNIT	(6) 30 DAY DS MAINTENANCE ALLOWANCE			(7) 30 DAY GS MAINTENANCE ALLOWANCE			(8) 1 YR ALW PER 100 EQUIP CNTGCTY	(9) DEPOT MAINT ALW PER 100 EQUIP	(10) ILLUSTRATION	
						(a)	(b)	(c)	(a)	(b)	(c)			(a) FIG NO.	(b) ITEM NO. OR REFERENCE DESIGNATION
						1-20	21-50	51-100	1-20	21-50	51-100				
P-D	5355-733-5548	KNOB-LOCK: 553-9731-002; (13499)		EA	1							*	*	A8A4MP43	
P-D	5310-151-9034	WASHER, FLAT: 553-5029-003; (13499)		EA	1							*	*	A8A4MP43H1	
P-D	5355-950-7576	KNOB-SMALL: 549-6190-002; (13499)		EA	1							*	*	A8A4MP44	
P-D	5305-638-1885	SETSCREW: 4-48X1-8 6SPLINEOVPT18-8SST; (08664)		EA	1							*	*	A8A4MP44H1	
P-D	5355-950-7574	KNOB-SWITCH: 549-6124-002; (13499)		EA	1							*	*	A8A4MP45	
P-D	5305-531-0137	SETSCREW: 335-0020-000; (08664)		EA	2							REF	REF	A8A4MP45H1	
P-D	5305-531-0137	SETSCREW: 335-0020-000; (08664)		EA	REF							REF	REF	A8A4MP45H2	
M-D		KNOB-VOLUME CONTROL: 549-6144-002; (13499)		EA	1									A8A4MP46	
P-D	5305-531-0137	SETSCREW: 335-0020-000; (08664)		EA	2							REF	REF	A8A4MP46H1	
P-D	5305-531-0137	SETSCREW: 335-0020-000; (08664)		EA	REF							REF	REF	A8A4MP46H2	
P-D	6240-155-7836	LAMP, INCANDESCENT: MS25237-387; (96906)		EA	4							*	*	A8A4DS1	
P-D	6240-155-7836	LAMP, INCANDESCENT: MS25237-387; (96906)		EA	REF							REF	REF	A8A4DS2	
P-D	6240-155-7836	LAMP, INCANDESCENT: MS25237-387; (96906)		EA	REF							REF	REF	A8A4DS101	
P-D	6240-155-7836	LAMP, INCANDESCENT: MS25237-387; (96906)		EA	REF							REF	REF	A8A4DS102	
P-D		LENS, INDICATOR LIGHT: MS25010; (96906)		EA	4							*	*	A8A4MP47	
P-D		LENS, INDICATOR LIGHT: MS25010; (96906)		EA	REF							REF	REF	A8A4MP48	
P-D		LENS, INDICATOR LIGHT: MS25010; (96906)		EA	REF							REF	REF	A8A4MP49	
P-D		LENS, INDICATOR LIGHT: MS25010; (96906)		EA	REF							REF	REF	A8A4MP50	
P-D	6210-791-9380	LENS, PANEL, LIGHT: 548-7909-002; (13499)		EA	2							*	*	A8A4MP51	
P-D	6210-791-9380	LENS, PANEL, LIGHT: 548-7909-002; (13 499)		EA	REF							REF	REF	A8A4MP52	
P-D		PANEL, SIGNAL DISTRIBUTION: 5449-6006-000; (13499)		EA	1									A8A4A6	
P-D	5305-151-6240	SCREW, MACHINE: P325-0080-000; (77250)		EA	3									A8A4A6H3	
P-D	5305-054-6670	SCREW, MACHINE: MS51957-45; (96906)		EA	6							*	*	A8A4A6H6	
P-D		WASHER, FLAT: P313-0046-000; (77250)		EA	9							*	*	A8A4A6H9	
P-D	5310-209-1074	WASHER, FLAT: 310-0048-000; (79807)		EA	3							REF	REF	A8A4A6H3	

SECTION II

TM 11-5820-509-35

REPAIR PARTS FOR DIRECT SUPPORT, GENERAL SUPPORT, AND DEPOT MAINTENANCE (Continued)															
(1) SMR CODE	(2) FEDERAL STOCK NUMBER	(3) DESCRIPTION Reference Number & Mfr. Code Usable on Code		(4) UNIT OF MEAS	(5) QTY INC IN UNIT	(6) 30 DAY DS MAINTENANCE ALLOWANCE			(7) 30 DAY GS MAINTENANCE ALLOWANCE			(8) 1 YR ALW PER 100 EQUIP CNTGCTY	(9) DEPOT MAINT ALW PER 100 EQUIP	(10) ILLUSTRATION	
						(a)	(b)	(c)	(a)	(b)	(c)			(a) FIG NO.	(b) ITEM NO. OR REFERENCE DESIGNATION
						1-20	21-50	51-100	1-20	21-50	51-100				
P-D	5310-933-8119	WASHER, LOCK, SPLIT: MS35335-137; (96906)		EA	6							REF	REF	A8A4A6H6	
P-D		WASHER, LOCK: 310-0283-000; (70318)		EA	3							*	*	A8A4A6H3	
M-D	5985-987-9019	BASE, ANTENNA: P57035; (70371)		EA	1									A8A4A6MP1	
P-D	5305-901-3604	SCREW, MACHINE: P343-0095-000; (77250)		EA	6							*	*	A8A4A6MP1H1	
P-D		SCREW, MACHINE: P343-0095-000; (77250)		EP.	REF							REF	REF	A8A4A6MP1H2	
P-D		SCREW, MACHINE: P343-0095-000; (77250)		EA	REF							REF	REF	A8A4A6MP1H3	
P-D		SCREW, MACHINE: P343-0095-000; (77250)		EA	REF							REF	REF	A8A4A6MP1H4	
P-D		SCREW, MACHINE: P343-0095-000; (77250)		EA	REF							REF	REF	A8A4A6MP1H5	
P-D		SCREW, MACHINE: P343-0095-000; (77250)		EA	REF							REF	REF	A8A4A6MP1H6	
P-D		WASHER, FLAT: 310-0048-000; (79807)		EA	6							REF	REF	A8A4A6MP1H7	
P-D		WASHER, FLAT: 310-0048-000; (79807)		EA	REF							REF	REF	A8A4A6MP1H8	
P-D		WASHER, FLAT: 310-0048-000; (79807)		EA	REF							REF	REF	A8A4A6MP1H9	
P-D		WASHER, FLAT: 310-0048-000; (79807)		EA	REF							REF	REF	A8A4A6MP1H10	
P-D		WASHER, FLAT: 310-0048-000; (79807)		EA	REF							REF	REF	A8A4A6MP1H11	
P-D		WASHER, FLAT: 310-0048-000; (79807)		EA	REF							REF	REF	A8A4A6MP1H12	
P-D	5310-551-9284	WASHER, NONMETALLIC: 302-0029-000; (05284)		EA	6							*	*	A8A4A6MP1H13	
P-D	5310-551-9284	WASHER, NONMETALLIC: 302-0029-000; (05284)		EA	REF							REF	REF	A8A4A6MP1H14	
P-D	5310-551-9284	WASHER, NONMETALLIC: 302-0029-030; (05284)		EA	REF							REF	REF	A8A4A6MP1H15	
P-D	5310-551-9284	WASHER, NONMETALLIC: 302-0029-000; (05284)		EA	REF							REF	REF	A8A4A6MP1H16	
P-D	5310-551-9284	WASHER, NONMETALLIC 302-0029-006; (05284)		EA	REF							REF	REF	A8A4A6MP1H17	
P-D	5310-551-9284	WASHER, NONMETALLIC 302-0029-000; (05284)		EA	REF							REF	REF	A8A4A6MP1H18	
P-D	5330-559-8909	WASHER, SEALING 110-8; (86579)		EA	6							*	*	A8A4A6MP1H19	
P-D	5330-559-8909	WASHER, SEALING 110-8; (86579)		EA	REF							REF	REF	A8A4A6MP1H20	
P-D	5330-559-8909	WASHER, SEALING 110-8; (86579)		EA	REF							REF	REF	A8A4A6MP1H21	
P-D	5330-559-8909	WASHER, SEALING 110-8; (86579)		EA	REF							REF	REF	A8A4A6MP1H22	

SECTION II

TM 11-5820-509-35

REPAIR PARTS FOR DIRECT SUPPORT, GENERAL SUPPORT, AND DEPOT MAINTENANCE (Continued)															
(1) SMR CODE	(2) FEDERAL STOCK NUMBER	(3) DESCRIPTION Reference Number & Mfr. Code Usable on Code		(4) UNIT OF MEAS	(5) QTY INC IN UNIT	(6) 30 DAY DS MAINTENANCE ALLOWANCE			(7) 30 DAY GS MAINTENANCE ALLOWANCE			(8) 1 YR ALW PER 100 EQUIP CNTGCTY	(9) DEPOT MAINT ALW PER 100 EQUIP	(10) ILLUSTRATION	
						(a)	(b)	(c)	(a)	(b)	(c)			(a) FIG NO.	(b) ITEM NO. OR REFERENCE DESIGNATION
						1-20	21-50	51-100	1-20	21-50	51-100				
P-D	5330-559-8909	WASHER, SEALING 110-8; (86579)		EA	REF							REF	REF	A8A4A6MP1H23	
P-D	5330-559-8909	WASHER, SEALING: 110-8; (86579)		EA	REF							REF	REF	A8A4A6MP1H24	
P-D		BEARING, BALL, ANNULAR: S6316FRHH3P15L02; (40920)		EA	9							REF	REF	A8A4A6MP2	
P-D		BEARING, BALL, ANNULAR: S6316FRHH3P15L02; (40920)		EA	REF							REF	REF	A8A4A6MP3	
P-D		BEARING, BALL, ANNULAR: S6316FRHH3P15L02; (40920)		EA	REF							REF	REF	A8A4A6MP4	
P-D		BEARING, BALL, ANNULAR: S6316FRHH3P15L02; (40920)		EA	REF							REF	REF	A8A4A6MP5	
P-D		BEARING, BALL, ANNULAR: S6316FRHH3P15L02; (40920)		EA	REF							REF	REF	A8A4A6MP6	
P-D		BEARING, BALL, ANNULAR: S6316FRHH3P15L02; (40920)		EA	REF							REF	REF	A8A4A6MP7	
P-D		BEARING, BALL, ANNULAR: S6316FRHH3P15L02; (40920)		EA	REF							REF	REF	A8A4A6MP8	
P-D		BEARING, BALL, ANNULAR : S6316FRHH3P15L02; (40920)		EA	REF							REF	REF	ABA4A6MP9	
P-D		BEARING, BALL, ANNULAR: S6316FRHH3P15L02; (40920)		EA	REF							REF	REF	A8A4A6MP10	
P-D	3120-865-8571	BEARING, SLEEVE 3L3F; (96881)		EA	7							REF	REF	A8A4A6MP11	
P-D	3120-865-8571	BEARING, SLEEVE 3L3F; (96881)		EA	REF							REF	REF	ABA4A6MP12	
P-D	3120-865-8571	BEARING, SLEEVE 3L3F; (96881)		EA	REF							REF	REF	A8A4A6MP13	
P-D	3120-865-8571	BEARING, SLEEVE 3L3F; (96881)		EA	REF							REF	REF	A8A4A6MP14	
P-D	3120-865-8571	BEARING, SLEEVE. 3L3F; (96881)		EA	REF							REF	REF	A8A4A6MP15	
P-D	3120-865-8571	BEARING, SLEEVE 3L3F; (96881)		EA	REF							REF	REF	A8A4A6MP16	
P-D	3120-865-8571	BEARING, SLEEVE 3L3F; (96881)		EA	REF							REF	REF	A8A4A6MP17	
P-D	5820-977-7652	BEARING, SLEEVE 549-6089-002; (13499)		EA	2							*	*	A8A4A6MP18	
P-D		NUT, HEXAGON 500-6308-001; (13499)		EA	1							*	*	A8A4A6MP18H1	
P-D	5820-977-7652	BEARING, SLEEVE 549-6089-002; (13499)		EA	REF							REF	REF	A8A4A6MP19	
P-D		NUT, HEXAGON 500-6308-001; (13499)		EA	1							REF	REF	ABA4A6MP19H1	
M-D	5820-977-1564	BLOCK, MOUNTING, FRONT 549-6100-002; (13 499)		EA	1									A8A4A6MP20	
P-D	5305-415-2207	SCREW, MACHINE P342-0025-000; (77250)		EA	1							*	*	ABA4A6MP20H1	
M-D	5820-977-1553	BLOCK, MOUNTING-METER SHIELD 549-6101-002; (13499)		EA	1									A8A4A6MP21	

SECTION II

TM 11-5820-509-35

REPAIR PARTS FOR DIRECT SUPPORT, GENERAL SUPPORT, AND DEPOT MAINTENANCE (Continued)															
(1) SMR CODE	(2) FEDERAL STOCK NUMBER	(3) DESCRIPTION Reference Number & Mfr. Code Usable on Code		(4) UNIT OF MEAS	(5) QTY INC IN UNIT	(6) 30 DAY DS MAINTENANCE ALLOWANCE			(7) 30 DAY GS MAINTENANCE ALLOWANCE			(8) 1 YR ALW PER 100 EQUIP CNTGCTY	(9) DEPOT MAINT ALW PER 100 EQUIP	(10) ILLUSTRATION	
						(a)	(b)	(c)	(a)	(b)	(c)			(a) FIG NO.	(b) ITEM NO. OR REFERENCE DESIGNATION
						1-20	21-50	51-100	1-20	21-50	51-100				
P-D	5305-054-6651	SCREW, MACHINE: MS51957-27; (96906)		EA	2							REF	REF	A8A4A6MP21H1	
P-D	5305-054-6651	SCREW, MACHINE: MS51957-27; (96906)		EA	REF							REF	REF	A8A4A6MP21H2	
P-D	3040-950-9578	COLLAR, SHAFT-NO. 1: 549-6021-002; (13499)		EA	6									A8A4A6MP22	
P-D	5305-716-7733	SETSCREW: MS51053-426; (96906)		EA	2							*	*	A8A4A6MP22H1	
P-D		SETSCREW: MS51053-426; (96906)		EA	REF							REF	REF	A8A4A6MP22H2	
M-D	3040-950-9578	COLLAR, SHAFT-NO. 1: 549-6021-002; (13499)		EA	REF									A8ARA6MP23	
P-D		SETSCREW: MS51053-426; (96906)		EA	2							REF	REF	A8A4A6MP23H1	
P-D		SETSCREW: MS51053-426; (96906)		EA	REF							REF	REF	A8A4A6MP23H2	
P-D	3040-950-9578	COLLAR, SHAFT-NO. 1: 549-6021-002; (13499)		EA	REF									A8A4A6MP24	
P-D		SETSCREW: MS51053-426; (96906)		EA	2							REF	REF	A8A4A6MP24H1	
P-D		SETSCREW: MS51053-426; (96906)		EA	REF							REF	REF	A8A4A6MP24H2	
P-D	3040-950-9578	COLLAR, SHAFT-NO. 1: 549-6021-002; (13499)		EA	REF									A8A4A6MP25	
P-D		SETSCREW: MS51053-426; (96906)		EA	2							REF	REF	A8A4A6MP25H1	
P-D		SETSCREW: MS51053-426; (96906)		EA	REF							REF	REF	A8A4A6MP25H2	
M-D	3040-950-9578	COLLAR, SHAFT-NO. 1: 549-6021-002; (13499)		EA	REF									A8A4A6MP26	
P-D		SETSCREW: MS51053-426; (96906)		EA	2							REF	REF	A8A4A6MP26H1	
P-D		SETSCREW: MS51053-426; (96906)		EA	REF							REF	REF	A8A4A6MP26H2	
P-D	3040-950-9578	COLLAR, S HAFT-NO. 1: 549-6021-002; (13499)		EA	REF									A8A4A6MP27	
P-D		SETSCREW: MS51053-26; (96906)		EA	2							REF	REF	A8A4A6MP27H1	
P-D		SETSCREW: MS51053-426; (96906)		EA	REF							REF	REF	A8A4A6MP27H2	
P-D		CONTACT ASSEMBLY, ELECTRICAL-1: 549-6103-002; (13499)		EA	2							*	*	A8A4A6E1	
P-D	5305-297-4351	SCREW, MACHINE: P342-0165-000; (77250)		EA	2							*	*	A8A4A6E1H1	
P-D		SCREW, MACHINE: P342-0165-000; (77250)		EA	REF							REF	REF	A8A4A6E1H2	
P-D		CONTACT ASSEMBLY, ELECTRICAL-: 549-6103-002; (13499)		EA	REF							REF	REF	A8A4A6E2	
P-D		SCREW, MACHINE: P342-0165-000; (77250)		EA	2							REF	REF	A8A4A6E2H1	

SECTION II

TM 11-5820-509-35

REPAIR PARTS FOR DIRECT SUPPORT, GENERAL SUPPORT, AND DEPOT MAINTENANCE (Continued)															
(1) SMR CODE	(2) FEDERAL STOCK NUMBER	(3) DESCRIPTION Reference Number & Mfr. Code Usable on Code		(4) UNIT OF MEAS	(5) QTY INC IN UNIT	(6) 30 DAY DS MAINTENANCE ALLOWANCE			(7) 30 DAY GS MAINTENANCE ALLOWANCE			(8) 1 YR ALW PER 100 EQUIP CNTGCTY	(9) DEPOT MAINT ALW PER 100 EQUIP	(10) ILLUSTRATION	
						(a)	(b)	(c)	(a)	(b)	(c)			(a) FIG NO.	(b) ITEM NO. OR REFERENCE DESIGNATION
						1-20	21-50	51-100	1-20	21-50	51-100				
P-D		SCREW, MACHINE: P342-0165-000; (77250)		EA	REF							REF	REF	A8A4A6E2H2	
M-D		COUPLING, HALF, SHAFT, NO. 2: 549-6048-002; (13499)		EA	1									A8A4A6MP61	
M-D		COUPLING, HALF, SHAFT, NO 3: 5149-6049-002; (13499)		EA	2									A8A4A6MP28	
M-D		COUPLING, HALF, SHAFT, NO. 3: 549-6049-002; (13499)		EA	REF									A8A4A6MP29	
M-D		GASKET, BEARING: 549-6090-002; (13499)		EA	2									A8A4A6MP30	
M-D		GASKET, BEARING: 549-6090-002; (13499)		EA	REF									A8A4A6MP31	
M-D	5330-618-3447	GASKET, RUBBER, CIRCULAR: MS9021-008; (96906)		EA	3									A8A4A6MP32	
M-D	5330-618-3447	GASKET, RUBBER, CIRCULAR: MS9021-008; (96906)		EA	REF									A8A4A6MP33	
M-D	5330-618-3447	GASKET, RUBBER, CIRCULAR: MS9021-008; (969 06)		EA	REF									A8A4A6MP34	
M-D		GASKET, TERMINAL FEED THRU: 549-6091-002; (13499)		EA	1									A8A4A6MP35	
P-H-T	5820-977-1563	GEAR ASSEMBLY, BEVEL, SPUR, NO. 1: 5149-6045-002; (13499)		EA	1				*	*	1	8	3	A8A4A6A1	
X1-D		GEAR, BEVEL, NO 1: 549-6029-002; (13499)		EA	1									A8A4A6A1MP1	
X1-D		GEAR, SPUR, NO. 6 549-6042-002; (13499)		EA	1									A8A4A6A1MP2	
X1-D		PIN, GROOVED, HEADLESS MS35672-1; (96906)		EA	2									A8A4A6A1MP3	
X1-D		PIN, GROOVED, HEADLESS MS35672-1; (96906)		EA	REF									A8A4A6A1MP4	
X1-D		PIN, GROOVED, HEADLESS MS35672-7; (96906)		EA	1									A8A4A6A1MP5	
X1-D		SHAFT, STRAIGHT-NO 4 549-6050-002; (13499)		EA	1									A8A4A6A1MP6	
P-D	5820 -977-1558	GEAR ASSEMBLY, BEVEL, SPUR-NO 3 549-6047-002; (13499)		EA	1							8	3	A8A4A6A2	
X1-D		GEAR, BEVEL, NO 1: 549-6029-002; (13499)		EA	1									A8A4A6A2MP1	
X1-D		GEAR, SPUR, NO. 9: 549-6043-002; (13499)		EA	1									A8A4A6A2MP2	
X1-D		PIN, GROOVED, HEADLESS: MS35672-1; (96906)		EA	2									A8A4A6A2MP3	
X1-D		PIN, GROOVED, HEADLESS: MS35672-1; (96906)		EA	REF									A8A4A6A2MP4	
X1-D		PIN, GROOVED, HEADLESS: MS35672-7; (96906)		EA	1									A8A4A6A2MP5	
X1-D		SHAFT, STRAIGHT-NO 2: 549-6041-002; (13499)		EA	1									A8A4A6A2MP6	
P-D	3020-976-5392	GEAR ASSEMBLY, SPUR-NO. 1: 549-6104-002; (13499)		EA	1							8	3	A8A4A6A3	

SECTION II

TM 11-5820-509-35

REPAIR PARTS FOR DIRECT SUPPORT, GENERAL SUPPORT, AND DEPOT MAINTENANCE (Continued)															
(1) SMR CODE	(2) FEDERAL STOCK NUMBER	(3) DESCRIPTION Reference Number & Mfr. Code Usable on Code		(4) UNIT OF MEAS	(5) QTY INC IN UNIT	(6) 30 DAY DS MAINTENANCE ALLOWANCE			(7) 30 DAY GS MAINTENANCE ALLOWANCE			(8) 1 YR ALW PER 100 EQUIP CNTGCTY	(9) DEPOT MAINT ALW PER 100 EQUIP	(10) ILLUSTRATION	
						(a)	(b)	(c)	(a)	(b)	(c)			(a) FIG NO.	(b) ITEM NO. OR REFERENCE DESIGNATION
						1-20	21-50	51-100	1-20	21-50	51-100				
X1-D		GEAR, SPUR, NO 1: 549-6092-002; (13499)		EA	1										A8A4A6A3MP1
X1-D		PIN, SPRING: MS16562-190; (96906)		EA	1										A8A4A6A3MP2
X1-D		STOP, DIAL, NO. 2: 549-6094-002; (13499)		EA	1										A8A4A6A3MP3
X1-D		SCREW, MACHINE: MS51959-12; (96906)		EA	1										A8A4A6A3MP3H1
P-D	3020-088-6021	GEAR, BEVEL, NO 2: 549-6121-002; (13499)		EA	1						8	3			A8A4A6MP36
P-D		SETSCREW: MS51053-L26; (96906)		EA	2						REF	REF			A8A4A6MP36H1
P-D		SETSCREW: MS51053-426; (96906)		EA	REF						REF	REF			A8A4A6MP36H2
P-D	5820-977-1559	GEARSHAFT, BEVEL, SPUR-PRESSED 549-6055-002; (13499)		EA	1						8	3			A8A4A6A4
X1-D		GEAR, BEVEL, NO 2: 549-6038-002; (13499)		EA	1										A8A4A6A4MP1
X1-D		GEARSHAFT, SPUR-NO. 1: 549-6033-002; (13499)		EA	1										A8A4A6A4MP2
M-D		GEARSHAFT-COUPLER ASSEMBLY: 549-6046-002; (13499)		EA	1										A8A4A6A5
S4-D		COUPLING HALF, SHAFT-NO. 1: 549-6040-002; (13499)		EA	1										A8A4A6A5MP1
P-D	5305-766-2422	SCREW, MACHINE: MS51959-1; (96906)		EA	4						33	20			A8A4A6A5MP1H1
P-D	5305-766-2422	SCREW, MACHINE: MS51959-1; (96906)		EA	REF						REF	REF			A8A4A6A5MP1H2
P-D	5305-766-2422	SCREW, MACHINE: MS51959-1; (96906)		EA	REF						REF	REF			A8A4A6A5MP1H3
P-D	5305-766-2422	SCREW, MACHINE: MS51959-1; (96906)		EA	REF						REF	REF			A8A4A6A5MP1H4
P-D	3040-977-1551	GEARSHAFT, SPUR-NO 2: 549-6034-002; (13499)		EA	1						8	3			A8A4A6MP37
P-D	5820-977-1558	GEARSHAFT, SPUR-12 TEETH: 549-6030-002; (13499)		EA	1						8	3			A8A4A6MP38
P-D		GEAR, SPUR, DETENT: 549-6052-002; (13499)		EA	1						8	3			A3A4A6MP39
P-D		GEAR, SPUR, NO.: 549-6036-0002; (13499)		EA	1						8	3			A8A4A6MP40
P-D	3020-985-2235	GEAR, SPUR, NO 4: 549-6039-002; (13499)		EA	1						8	3			A8A4A6A6
X1-D		HUB-GEAR: 549-6035-002; (13499)		EA	1										A8A4A6A6MP1
P-D	5305-764-2966	SCREW, MACHINE: MS51959-2; (96906)		EA	4						REF	RE			A8A4A6A6MP1H1
P-D	5305-764-2966	SCREW, MACHINE: MS51959-2; (96906)		EA	REF						REF	REF			A8A4A6A6MP1H2
P-D	5305-764-2966	SCREW, MACHINE: MS51959-2; (96906)		EA	REF						REF	REF			A8A4A6A6MP1H3

SECTION II

TM 11-5820-509-35

REPAIR PARTS FOR DIRECT SUPPORT, GENERAL SUPPORT, AND DEPOT MAINTENANCE (Continued)															
(1) SMR CODE	(2) FEDERAL STOCK NUMBER	(3) DESCRIPTION Reference Number & Mfr. Code Usable on Code		(4) UNIT OF MEAS	(5) QTY INC IN UNIT	(6) 30 DAY DS MAINTENANCE ALLOWANCE			(7) 30 DAY GS MAINTENANCE ALLOWANCE			(8) 1 YR ALW PER 100 EQUIP CNTGCTY	(9) DEPOT MAINT ALW PER 100 EQUIP	(10) ILLUSTRATION	
						(a)	(b)	(c)	(a)	(b)	(c)			(a) FIG NO.	(b) ITEM NO. OR REFERENCE DESIGNATION
						1-20	21-50	51-100	1-20	21-50	51-100				
P-D	5305-764-2966	SCREW, MACHINE: MS51959-2; (96906)		EA	REF							REF	REF	A8A4A6MP1H4	
P-D	3020-985-2236	GEAR, SPUR, 12T DETENT: 549-6065-002; (13499)		EA	1							8	3	A8A4A6MP62	
P-D		GEAR, SPUR, 32 TEETH: 549-6044-002; (13499)		EA	1							8	3	A8A4A6MP63	
P-D	3020-088-4507	GEAR, SPUR, 54 TEETH: 549-6054-002; (13499)		EA	1							6	3	A8A4A6MP64	
P-D	3020-988-0687	GEAR, SPUR, 60 TEETH: 549-6037-002; (13499)		EA	1							8	3	A8A4A6MP41	
P-D	3020-098-1785	GEAR, SPUR, 69 TEETH: 549-6060-002; (13499)		EA	1							8	3	A8A4A6MP42	
P-D	3020-988-6910	GEAR, SPUR, 78T, RIVETED: 59-6066-002; (13499)		EA	1							8	3	A8A4A6MP43	
P-D	5820-977-1560	GEAR, STOP, NO 1, RIVETED: 549-6078-002; (13499)		EA	1							8	3	A8A4A6MP44	
P-D		SETSCREW: 6-40X1-4-6SPLINE416SST; (08664)		EA	1							12	5	A8A4A6MP44H1	
P-D	5820-977-1561	GEAR, STOP, NO. 2: 549-6079-002; (13499)		EA	1							8	3	A8A4A6MP45	
M-D		HANDLE, BOW-THREADED: 549-6087-002; (13499)		EA	2									A8A4A6MP46	
P-D	5305-942-8431	SCREW, MACHINE: P347-0053-000; (77250)		EA	2							33	20	A8A4A6MP46H1	
P-D	5305-942-8431	SCREW, MACHINE P347-0053-000; (77250)		EA	REF							REF	REF	A8A4A6MP46H2	
P-D	5310-933-8119	WASHER, LOCK: MS35338-137; (96906)		EA	2							REF	REF	A8A4A6MP46H3	
P-D	5310-933-8119	WASHER, LOCK: MS35338-137; (96906)		EA	REF							REF	REF	A8A4A6MP46H4	
P-D	5330-559-8909	WASHER, SEALING: 110-8; (86579)		EA	2							REF	REF	A8A4A6MP46H5	
P-D	5330-559-8909	WASHER, SEALING: 110-8; (86579)		EA	REF							REF	REF	A8A4A6MP46H6	
M-D		HANDLE, BOW-THREADED: 549-6087-002; (13499)		EA	REF									A8A4A6MP47	
P-D		SCREW, MACHINE: P347-0053-000; (77250)		EA	2							REF	REF	A8A4A6MP47H1	
P-D		SCREW, MACHINE: P347-0053-000; (77250)		EA	REF							REF	REF	A8A4A6MP47H2	
P-D	5310-933-8119	WASHER, LOCK: MS35338-137; (96906)		EA	2							REF	REF	A8A4A6MP47H3	
P-D	5310-933-8119	WASHER, LOCK: MS35338-137; (96906)		EA	REF							REF	REF	A8A4A6MP47H4	
P-D	5330-559-8909	WASHER, SEALING: 110-8; (86579)		EA	2							REF	REF	A8A4A6MP47H5	
P-D	5330-559-8909	WASHER, SEALING: 110-8; (86579)		EA	REF							REF	REF	A8A4A6MP47H6	
P-H-T	5820-984-1770	INDICATOR, FREQUENCY CHANNEL: 549-6116-004; (13499)		EA	1				*	*	*	5	2	A8A4A6A7	

SECTION II

TM 11-5820-509-35

REPAIR PARTS FOR DIRECT SUPPORT, GENERAL SUPPORT, AND DEPOT MAINTENANCE (Continued)															
(1) SMR CODE	(2) FEDERAL STOCK NUMBER	(3) DESCRIPTION Reference Number & Mfr. Code Usable on Code		(4) UNIT OF MEAS	(5) QTY INC IN UNIT	(6) 30 DAY DS MAINTENANCE ALLOWANCE			(7) 30 DAY GS MAINTENANCE ALLOWANCE			(8) 1 YR ALW PER 100 EQUIP CNTGCTY	(9) DEPOT MAINT ALW PER 100 EQUIP	(10) ILLUSTRATION	
						(a)	(b)	(c)	(a)	(b)	(c)			(a) FIG NO.	(b) ITEM NO. OR REFERENCE DESIGNATION
						1-20	21-50	51-100	1-20	21-50	51-100				
P-D	5305-054-5648	SCREW, MACHINE: MS51957-14; (96906)		EA	3							REF	REF	A8A4A6A7H3	
P-D	5310-058-2949	WASHER, LOCK: 310-0278-000; (70318)		EA	3							REF	REF	A8A4A6A7H3	
X1-D		BRACKET, INDICATOR, PRESSED: 549-6113-003; (13499)		EA	1									A8A4A6A7A1	
X1-D		BRACKET, INDICATOR: 549-6254-004; (13499)		EA	1									A8A4A6A7A1MP1	
X1-D		GEAR, SPUR, 8 TEETH: 541-8646-002; (13499)		EA	1									A8A4A6A7A1MP2	
X1-D		PIN, GROOVED, HEADLESS: GP4-125X0250-50; (73957)		EA	2									A8A4A6A7A1MP3	
X1-D		PIN, GROOVED, HEADLESS: GP4-125X0250-50; (73957)		EA	REF									A8A4A6A7A1MP4	
X1-D		SHAFT, STRAIGHT-TRANSFER: 549-6015-002; (13499)		EA	1									A8A4A6A7A1MP5	
X1-D		DIAL, SCALE, NO. 1 RIVETED: 549-6010-002; (13499)		EA	1									A8A4A6A7MP1	
X1-D		DIAL, SCALE, NO. 2 RIVETED: 549-6011-002; (13499)		EA	1									A8A4A6A7MP2	
X1-D		DIAL, SCALE, NO. 3 RIVETED: 549-6012-002; (13499)		EA	1									A8A4A6A7MP3	
X1-D		DIAL, SCALE, NO. 4 RIVETED: 519-6013-002; (13499)		EA	1									A8A4A6A7MP4	
X1-D		GEAR, 40 TEETH: 544-2986-002; (13499)		EA	1									A8A4A6A7MP5	
X1-D		GEAR, BEVEL, NO. 3: 549-6051-002; (13499)		EA	5									A8A4A6A7MP6	
X1-D		SETSCREW: 4-48x1-8 6SPLINE0VPT18-8SST; (08664)		EA	2									A8A4A6A7MP6H1	
X1-D		SETSCREW: 4-48X1-8 6SPLINE0VPT18-8SST; (08664)		EA	REF									A8A4A6A7MP6H2	
X1-D		GEAR, BEVEL, NO. 3: 549-6051-002; (13499)		EA	REF									A8A4A6A7MP7	
X1-D		SETSCREW: 4-48x1-8 6SPLINEDOPT18-8SST; (08664)		EA	2									A8A4A6A7MP7H1	
X1-D		SETSCREW: 4-48x1-8 6SPLINE0VPT18-8SST; (08664)		EA	REF									A8A4A6A7MP7H2	
X1-D		GEAR, BEVEL, NO. 3: 549-6051-002; (13499)		EA	REF									A8A4A6A7MP8	
X1-D		SETSCREW- 4-48X1-8 6SPLINE0VPT18-8SST; (08664)		EA	2									A8A4A6A7MP8H1	
X1-D		SETSCREW 4-48X1-8 6SPLINE0VPT18-8SST; (08664)		EA	REF									A8A4A6A7MP8H2	
X1-D		GEAR, BEVEL, NO. 3: 549-6051-002; (134 99)		EA	REF									A8A4A6A7MP9	
X1-D		SETSCREW 4-48X1-8 (SPLINE0VPT18-8SST; (08664)		EA	2									A8A4A6A7MP9H1	
X1-D		SETSCREW. 4-48x1-8 6SPLINE0VPT18-8SST; (08664)		EA	REF									A8A4A6A7MP9H2	

SECTION II

TM 11-5820-509-35

REPAIR PARTS FOR DIRECT SUPPORT, GENERAL SUPPORT, AND DEPOT MAINTENANCE (Continued)															
(1) SMR CODE	(2) FEDERAL STOCK NUMBER	(3) DESCRIPTION Reference Number & Mfr. Code Usable on Code		(4) UNIT OF MEAS	(5) QTY INC IN UNIT	(6) 30 DAY DS MAINTENANCE ALLOWANCE			(7) 30 DAY GS MAINTENANCE ALLOWANCE			(8) 1 YR ALW PER 100 EQUIP CNTGCTY	(9) DEPOT MAINT ALW PER 100 EQUIP	(10) ILLUSTRATION	
						(a) 1-20	(b) 21-50	(c) 51-100	(a) 1-20	(b) 21-50	(c) 51-100			(a) FIG NO.	(b) ITEM NO. OR REFERENCE DESIGNATION
X1-D		GEAR, BEVEL, NO 3: 549-6051-002; (13499)		EA	REF										A8A4A6A7MP10
X1-D		SETSCREW: 4-48X1-8 6SPLINE0VPT18-8SST; (08664)		EA	2										A8A4A6A7MP10H1
X1-D		SETSCREW: 4-48X1-8 6SPLINE0VPT18-8SST (08664)		EA	REF										A8A4A6A7MP10H2
X1-D		GEAR, CLUSTER, BEVEL-SPUR: 549-6024-002; (13499)		EA]]										A8A4A6A7A2
X1-D		GEAR, BEVEL-COUNTER: 549-6022-002; (13499)		EA	1										A8A4A6A7A2MP1
X1-D		GEAR, SPUR-COUNTER: 549-6023-002; (13499)		EA	1										A8A4A6A7A2MP2
X1-D		GEARSHAFT, BEVEL PINNED: 549-6225-002; (13499)		EA	2										A8A4A6A7A3
X1-D		GEAR, BEVEL: 549-6224-002; (13499)		EA	2										A8A4A6A7A3MP1
X1-D		PIN, SPRING: MS16562-192; (96906)		EA	2										A8A4A6A7A3MP2
X1-D		SHAFT, SHOULDERED, COUNTER: 5R9-6018-002; (13499)		EA	2										A8A4A6A7A3MP3
X1-D		GEARSHAFT, BEVEL PINNED: 549-6225-002; (13499)		EA	REF										A8A4A6A7A4
X1-D		GEAR, BEVEL: 549-6224-002; (13499)		EA	REF										A8A4A6A7A4MP1
X1-D		PIN, SPRING: MS16562-192; (96906)		EA	REF										A8A4A6A7A4MP2
X1-D		SHAFT, SHOULDERED, COUNTER: 549-6018-002; (13499)		EA	REF										A8A4A6A7A4MP3
X1-D		GEAR, SPUR, 36 TEETH: 549-6058-002; (13499)		EA	1										A8A4A6A7MP11
X1-D		PIN, SPRING: MS16562-192; (96906)		EA	2										A8A4A6A7MP12
X1-D		PIN, SPRING: MS16562-192; (96906)		EA	REF										A8A4A6A7MP13
X1-D		RING, RETAINING: MS16632-1018; (96906)		EA	1										A8A4A6A7H1
X1-D		RING, RETAINING: 5133-15C; (79136)		EA	2										A8A4A6A7H2
X1-D		RING, RETAINING: 5133-15C; (79136)		EA	REF										A8A4A6A7H3
X1-D		RING, RETAINING: 5133-18C; (79136)		EA	2										A8A4A6A7H4
X1-D		RING, RETAINING: 5133-18C; (79136)		EA	REF										A8A4A6A7H5
X1-D		SHAFT, SHOULDERED: 549-6053-002; (13499)		EA	1										A8A4A6A7MP14
X1-D		SHAFT, STRAIGHT-COUNTER: 549-6014-002; (13499)		EA	1										A8A4A6A7MP15
X1-D		SHAFT, STRAIGHT-NO 1: 549-6016-002; (13499)		EA	1										A8A4A6A7MP16

SECTION II

TM 11-5820-509-35

REPAIR PARTS FOR DIRECT SUPPORT, GENERAL SUPPORT, AND DEPOT MAINTENANCE (Continued)															
(1) SMR CODE	(2) FEDERAL STOCK NUMBER	(3) DESCRIPTION Reference Number & Mfr. Code Usable on Code		(4) UNIT OF MEAS	(5) QTY INC IN UNIT	(6) 30 DAY DS MAINTENANCE ALLOWANCE			(7) 30 DAY GS MAINTENANCE ALLOWANCE			(8) 1 YR ALW PER 100 EQUIP CNTGCTY	(9) DEPOT MAINT ALW PER 100 EQUIP	(10) ILLUSTRATION	
						(a)	(b)	(c)	(a)	(b)	(c)			(a) FIG NO.	(b) ITEM NO. OR REFERENCE DESIGNATION
						1-20	21-50	51-100	1-20	21-50	51-100				
X1-D		SHAFT, STRAIGHT-NO. 2: 549-6507-002; (13499)		EA	1										A8A4A6A7MP17
P-D	5355-951-4083	KNOB: 549-6077-002,		EA	3							*	*		A8A4A6MP48
P-D		SETSCREW: MS51053-426; (96906)		EA	2							REF	REF		A8A4A6MP48H1
P-D		SETSCREW: MS51053-426; (96906)		EA	REF							REF	REF		A8A4A6MP48H2
P-D	5355-951-4083	KNOB: 549-6077-002; (1 3499)		EA	REF							REF	REF		A8A4A6P49
P-D		SETSCREW: MS51053-426; (96906)		EA	2							REF	REF		A8A4A6MP49H1
P-D		SETSCREW: MS51053-426; (96906)		EA	REF							REF	REF		A8A4A6MP49H2
P-D	5355-951-4083	KNOB: 549-6077-002; (13499)		EA	REF							REF	REF		A8A4A6MP50
P-D		SETSCREW: MS51053-426; (96906)		EA	2							REF	REF		A8A4A6MP50H1
P-D		SETSCREW: MS51053-426; (96906)		EA	REF							REF	REF		A8A4A6MP50H2
P-D		NUT, SLEEVE, NO 1: 549-6025-002; (13499)		EA	3							*	*		A8A4A6M51
P-D		SCREW, MACHINE: P342-0026-000; (77250)		EA	1							REF	REF		A8A4A6MP51H1
P-D		NUT, SLEEVE, NO 1: 549-6025-002; (13499)		EA	REF							REF	REF		A8A4A6MP51H2
P-D		SCREW, MACHINE: P342-0026-00000; (77250)		EA	1							REF	REF		A8A4A6MP51H3
P-D		NUT, SLEEVE, NO. 1: 549-6025-002; (13499)		EA	REF							REF	REF		A8A4A6MP52
P-D		SCREW, MACHINE: P342-0026-000; (77250)		EA	1							REF	REF		A8A4A6MP52H1
P-D		NUT, SLEEVE, NO 2: 549-6028-002; (13499)		EA	2							*	*		A8A4A6MP53
P-D		SCREW, MACHINE: P342-0026-000; (77250)		EA	1							REF	REF		A8A4A6MP53H1
P-D		NUT, SLEEVE, NO. 2: 549-6028-002; (13499)		EA	REF							REF	REF		A8A4A6MP54
P-D		SCREW, MACHINE: P32-0026-000; (77250)		EA	1							REF	REF		A8A4A6MP54H1
A-H-T		PANEL, FRONT, PRESSED: 549-6122-005; (13499)		EA	1										A8A4A6A8
P-D	5315-881-2253	PIN, SPRING: MS16562-221; (96906)		EA	2							*	*		A8A4A6A8MP1
P-D	5315-881-2255	PIN, SPRING: MS16562-221; (96906)		EA	REF							REF	REF		A8A4A6A8MP2
P-D	5340-157-7856	POST, ELECTRICAL-MECHANICAL EQUIPMENT: 553-6329-003; (13499)		EA	1							*	*		A8A4A6ABMP3
P-D	5305-455-2549	SCREW, MACHINE: P342-0023-000; (77250)		EA	1							*	*		A8A4A6A8MP3H1

SECTION II

TM 11-5820-509-35

REPAIR PARTS FOR DIRECT SUPPORT, GENERAL SUPPORT, AND DEPOT MAINTENANCE (Continued)															
(1) SMR CODE	(2) FEDERAL STOCK NUMBER	(3) DESCRIPTION Reference Number & Mfr. Code Usable on Code		(4) UNIT OF MEAS	(5) QTY INC IN UNIT	(6) 30 DAY DS MAINTENANCE ALLOWANCE			(7) 30 DAY GS MAINTENANCE ALLOWANCE			(8) 1 YR ALW PER 100 EQUIP CNTGCTY	(9) DEPOT MAINT ALW PER 100 EQUIP	(10) ILLUSTRATION	
						(a)	(b)	(c)	(a)	(b)	(c)			(a) FIG NO.	(b) ITEM NO. OR REFERENCE DESIGNATION
						1-20	21-50	51-100	1-20	21-50	51-100				
P-D	5820-007-9538	POST, IDLER: 549-6056-002; (13499)		EA	3							*	*	A8A4A6A8MP4	
P-D		POST, IDLER: 549-6056-002; (13191)		EA	REF							REF	REF	A8A4A6A8MP5	
P-D		POST, IDLER: 549-6056-002; (13499)		EA	REF							REF	REF	A8A4A6A8MP6	
P-D	5820-187-3932	POST, IDLER: 549-6056-002; (13499)		EA	1							*	*	A8A4A6A8MP7	
P-D	5820-976-9776	PAWL, 12-POSITION, NO. 2-PRESSED: 549-6080-002; (13499)		EA	1							*	*	A8A4A6A9	
X1-D		PAWL, 12-POSITION: 549-6075-002; (13499)		EA	1									A8A4A6A9MP1	
X1-D		PIN, SPRING: MS16562-209; (96906)		EA	1									A8A4A6A9MP2	
X1-D		SPRING, HELICAL, EXTENSION: 500-2179-002; (13499)		EA	1									A8A4A6A9MP3	
P-D	5820-976-9777	PAWL, 12-POSITION, NO. 3-PRESSED: 549-6082-002; (13499)		EA	1							*	*	A8A4A6A10	
X1-D		PAWL, 12-POSITION: 549-6085-002; (13499)		EA	1									A8A4A6A10MP1	
X1-D		PIN, SPRING: MS16562-209; (96906)		EA	1									A8A4A6A10MP2	
X1-D		SPRING, HELICAL, EXTENSION: 756-5247-002; (13499)		EA	1									A8A4A6A10MP3	
P-D	5820-976-9775	PAWL, 12-POSITION, PRESSED: 549-6086-002; (13499)		EA	1							*	*	A8A4A6A11	
X1-D		PAWL, 12-POSITION: 549-6085-002; (13499)		EA	1									A8A4A6A11MP1	
X1-D		PIN, SPRING: MS16562-209; (96906)		EA	1									A8A4A6A11MP2	
X1-D		SPRING, HELICAL, EXTENSION: 500-2179-002; (13499)		EA	1									A8A4A6A11MP3	
P-D	5820-006-9735	PLATE, GEAR, PRESSED: 549-6118-004; (13499)		EA	1							*	*	A8A4A6A12	
P-D	5305-054-6652	SCREW, MACHINE: MS51957-28; (96906)		EA	5							REF	REF	A8A4A6A12H5	
P-D		WASHER, FLAT: 310-0046-000; (79807)		EA	1							REF	REF	A8A4A6A12H1	
P-D	5310-271-7446	WASHER, LOCK: 310-0071-000; (79807)		EA	5							REF	REF	A8A4A6A12H5	
X1-D		PLATE, GEAR 549-6117-004; (13499)		EA	1									A8A4A6A12MP1	
X1-D		POST, KNOB STOP 549-6070-002; (13499)		EA	1									A8A4A6A12MP2	
P-D		POST, BINDING 78411; (72825)		EA	2							*	*	A8A4A6E3	
P-D	5305-206-3716	SCREW, MACHINE P343-0330-000; (77250)		EA	1							*	*	A8A4A6E3H1	
P-D	5310-184-8978	WASHER, LOCK 310-0078-000; (79807)		EA	1							REF	REF	A8A4A6E3H2	

SECTION II

TM 11-5820-509-35

REPAIR PARTS FOR DIRECT SUPPORT, GENERAL SUPPORT, AND DEPOT MAINTENANCE (Continued)															
(1) SMR CODE	(2) FEDERAL STOCK NUMBER	(3) DESCRIPTION Reference Number & Mfr. Code Usable on Code		(4) UNIT OF MEAS	(5) QTY INC IN UNIT	(6) 30 DAY DS MAINTENANCE ALLOWANCE			(7) 30 DAY GS MAINTENANCE ALLOWANCE			(8) 1 YR ALW PER 100 EQUIP CNTGCTY	(9) DEPOT MAINT ALW PER 100 EQUIP	(10) ILLUSTRATION	
						(a)	(b)	(c)	(a)	(b)	(c)			(a) FIG NO.	(b) ITEM NO. OR REFERENCE DESIGNATION
						1-20	21-50	51-100	1-20	21-50	51-100				
P-D	5330-618-9563	WASHER, SEALING: 110-6; (86579)		EA	1							*			A8A4A6E3H3
P-D	5940-258-1836	POST, BINDING: 7841; (72825)		EA	REF							REF	REF		A8A4A6E4
P-D		SCREW, MACHINE: P343-0330-000; (77250)		EA	1							REF	REF		A8A4A6E4H1
P-D	5310-184-8978	WASHER, LOCK: 310-0078-000; (79807)		EA	1							REF	REF		A8A4A6E4H2
P-D	5330-618-9563	WASHER, SEALING: 110-6; (86579)		EA	1							REF	REF		A8A4A6E4H3
P-D		POST, PIVOT-CENTER KNOB: 549-6076-002; (13499)		EA	3							*	*		A8A4A6MP55
P-D	5310-262-6105	NUT, PLAIN, HEXAGON: P313-0045-000; (77250)		EA	1							REF	REF		A8A4A6MP55H1
P-D	5310-271-7446	WASHER, LOCK: 310-0071-000; (79807)		EA	1							REF	REF		A8A4A6MP55H2
P-D		POST, PIVOT-CENTER KNOB: 549-6076-002; (13499)		EA	REF							REF	REF		A8A4A6MP56
P-D	5310-262-6105	NUT, PLAIN, HEXAGON: P313-0045-000; (77250)		EA	1							REF	REF		A8A4A6MP56H1
P-D	5310-271-7446	WASHER, LOCK: 310-0071-000; (79807)		EA	1							REF	REF		A8A4A6MP56H2
P-D		POST, PIVOT-CENTER KNOB: 549-6076-002; (13499)		EA	REF							REF	REF		A8A4A6MP57
P-D	5310-262-6105	NUT, PLAIN, HEXAGON: P313-0045-000; (77250)		EA	1							REF	REF		A8A4A6MP57H1
P-D	5310-271-7446	WASHER, LOCK: 310-0071-000; (79807)		EA	1							REF	REF		A8A4A6MP57H2
P-D	5340-602-6075	RING, RETAINING: MS16624-18; (96906)		EA	3							*	*		A8A4A6H1
P-D	5340-602-6075	RING, RETAINING: MS16624-18; (96906)		EA	REF							REF	REF		A8A4A6H2
P-D	5340-602-6075	RING, RETAINING: MS16624-18; (96906)		EA	REF							REF	REF		A8A4A6H3
P-D	5340-720-8064	RING, RETAINING: MS16624-1025; (96906)		EA	1							*	*		A8A4A6H4
P-D	5340-634-7444	RING, RETAINING: MS16632-1018; (96906)		EA	4							*	*		A8A4A6H5
P-D	5340-634-7444	RING, RETAINING: MS16632-1018; (96906)		EA	REF							REF	REF		A8A4A6H6
P-D	5340-634-7444	RING, RETAINING: MS16632-1018; (96906)		EA	REF							REF	REF		A8A4A6H7
P-D	5340-634-7444	RING, RETAINING: MS16632-1018; (96906)		EA	REF							REF	REF		A8A4A6H8
P-D	5340-200-3475	RING, RETAINING: 5133-18C; (79136)		EA	6							*	*		A8A4A6H9
P-D	5340-200-3475	RING, RETAINING: 5133-18C; (79136)		EA	REF							REF	REF		A8A4A6H10
P-D	5340-200-3475	RING, RETAINING: 5133-18C; (79136)		EA	REF							REF	REF		A8A4A6H11

SECTION II

TM 11-5820-509-35

REPAIR PARTS FOR DIRECT SUPPORT, GENERAL SUPPORT, AND DEPOT MAINTENANCE (Continued)															
(1) SMR CODE	(2) FEDERAL STOCK NUMBER	(3) DESCRIPTION Reference Number & Mfr. Code Usable on Code		(4) UNIT OF MEAS	(5) QTY INC IN UNIT	(6) 30 DAY DS MAINTENANCE ALLOWANCE			(7) 30 DAY GS MAINTENANCE ALLOWANCE			(8) 1 YR ALW PER 100 EQUIP CNTGCTY	(9) DEPOT MAINT ALW PER 100 EQUIP	(10) ILLUSTRATION	
						(a)	(b)	(c)	(a)	(b)	(c)			(a) FIG NO.	(b) ITEM NO. OR REFERENCE DESIGNATION
						1-20	21-50	51-100	1-20	21-50	51-100				
P-D	5340-200-3475	RING, RETAINING: 5133-18C; (T9136)		EA	REF							REF	REF	A8A4A6H12	
P-D	5340-200-3475	RING, RETAINING: 5133-18C; (79136)		EA	REF							REF	REF	A8A4A6H13	
P-D	5340-200-3475	RING, RETAINING: 5133-18C; (79136)		EA	REF							REF	REF	A8A4A6H14	
P-D	5305-984-2144	SCREW, EYE: 549-6081-002; (13499)		EA	3							*	*	A8A4A6MP58	
P-D	5305-984-2144	SCREW, EYE: 549-6081-002; (13499)		EA	REF							REF	REF	A8A4A6MP59	
P-D	5305-984-2144	SCREW, EYE: 549-6081-002; (13499)		EA	REF							REF	REF	A8A4A6MP60	
M-D		SHIELD, METER: 549-6114-003; (13499)		EA	1									A8A4A6E5	
P-D		SCREW, SELF-LOCKING: LP51959-13M; (03038)		EA	4							REF	REF	A8A4A6E5H1	
P-D		SCREW, SELF-LOCKING: LP51959-13M; (03038)		EA	REF							REF	REF	A8A4A6E5H2	
P-D		SCREW, SELF-LOCKING: LP51959-13M; (03038)		EA	REF							REF	REF	A8A4A6E5H3	
P-D		SCREW, SELF-LOCKING: LP51959-13M; (03038)		EA	REF							REF	REF	A8A4A6E5H4	
P-D	5820-089-4996	STOP ASSEMBLY, DIAL: 553-9737-003; (13499)		EA	1							*	*	A8A4A6A13	
P-D		STUD, SHOULDERED: 553-9732-002; (13499)		EA	1							*	*	A8A4A6A13H1	
X1-D		PIN, GROOVED, HEADLESS: GP4-062X0250-50; (73957)		EA	2									A8A4A6A13MP1	
X1-D		PIN, GROOVED, HEADLESS: GP4-062X0250-50; (73957)		EA	REF									A8A4A6A13MP2	
X1-D		PLATE, SUPPORT-STOP: 553-9736-002; (13499)		EA	1									A8A4A6A13MP3	
X1-D		STOP, DIAL: 553-9735-002; (13499)		EA	1									A8A4A6A13MP4	
P-D	5940-156-7344	TERMINAL, LUG: 2104-06-02-2520N; (78189)		EA	1							*	*	A8A4A6E6	
P-D	5340-124-3383	WASHER: 543-5656-003; (13499)		EA	3							*	*	A8A4A6H15	
P-D	5340-124-3383	WASHER: 543-5656-003; (13499)		EA	REF							REF	REF	A8A4A6H16	
P-D	5340-124-3383	WASHER: 543-5656-003; (13499)		EA	REF							REF	REF	A8A4A6H17	
M-D		PLATE, CHART: 553-9773-002; (13499)		EA	1									A8A4MP53	
P-D	5305-439-2737	SCREW, MACHINE: P343 3-0018-000; (77250)		EA	4							*	*	A8A4MP53H1	
P-D		SCREW, MACHINE: P343-0018-000; (77250)		EA	REF							REF	REF	A8A4MP53H2	
P-D		SCREW, MACHINE: P343-0018-000; (77250)		EA	REF							REF	REF	A8A4MP53H3	

SECTION II

TM 11-5820-509-35

REPAIR PARTS FOR DIRECT SUPPORT, GENERAL SUPPORT, AND DEPOT MAINTENANCE (Continued)															
(1) SMR CODE	(2) FEDERAL STOCK NUMBER	(3) DESCRIPTION Reference Number & Mfr. Code Usable on Code		(4) UNIT OF MEAS	(5) QTY INC IN UNIT	(6) 30 DAY DS MAINTENANCE ALLOWANCE			(7) 30 DAY GS MAINTENANCE ALLOWANCE			(8) 1 YR ALW PER 100 EQUIP CNTGCTY	(9) DEPOT MAINT ALW PER 100 EQUIP	(10) ILLUSTRATION	
						(a)	(b)	(c)	(a)	(b)	(c)			(a) FIG NO.	(b) ITEM NO. OR REFERENCE DESIGNATION
						1-20	21-50	51-100	1-20	21-50	51-100				
P-D		SCREW, MACHINE: P33-0018-000; (77250)		EA	REF							REF	REF		A8A4MP53H4
P-D		PLATE, COVER: 549-6135-002; (13199)		EA	1										A8A4MP54
P-D	5305-721-3842	SCREW, MACHINE: P342-0024-000; (77250)		EA	4							*	*		A8A4MP54H1
P-D	5305-721-3842	SCREW, MACHINE: P342-0024-000; (77250)		EA	REF							REF	REF		A8A4MP54H2
P-D	5305-721-3842	SCREW, MACHINE: P342-0024-000; (77250)		EA	REF							REF	REF		A8A4MP54H3
P-D	5305-724-3842	SCREW, MACHINE: P342-0024-00; (77250)		EA	REF							REF	REF		A8A4MP54H4
P-D		PLATE, GEAR-REAR ROLLED: 549-6217-003; (13499)		EA	1							*	*		A8A4KP55
P-D	5305-054-6650	SCREW, MACHINE: MS51957-26; (96906)		EA	6							REF	REF		A8A4MP55H1
P-D	5305-054-6650	SCREW, MACHINE: MS51957-26; (96906)		EA	REF							REF	REF		A8A4MP55H2
P-D	5305-054-6650	SCREW, MACHINE: MS51957-26; (96906)		EA	REF							REF	REF		A8A4MP55H3
P-D	5305-054-6650	SCREW, MACHINE: MS51957-26; (96906)		EA	REF							REF	REF		A8A4MP55H4
P-D	5305-054-6650	SCREW, MACHINE: MS51957-26; (96906)		EA	REF							REF	REF		ABA4MP55H5
P-D	5305-054-6650	SCREW, MACHINE: MS51957-26; (96906)		EA	REF							REF	REF		A8A4MP55H6
P-D		PLATE, HEAT TRANSFER: 58-9319-002; (13499)		EA	2										A8A4MP56
M-D		PLATE, HEAT TRANSFER: 548-9319-002; (13;99)		EA	REF										A8A4MP57
P-D	6210-736-7715	REFLECTOR, LIGHT: 548-79080002; (13499)		EA	2							*	*		A8A4MP58
P-D	6210-736-7715	REFLECTOR, LIGHT: 5&8-7908-002; (13499)		EA	REF							REF	REF		ABA4MP59
P-D	5945-105-4267	RELAY, ARMATURE: 3SBF1054A2; (01526)		EA	1							*	*		A8A4K6
P-D	5310-614-3500	NUT, SELF-LOCKING, HEXAGON: 68-1660-40; (72962)		EA	2							REF	REF		A8A4K6H1
P-D	5310-614-3500	NUT, SELF-LOCKING, HEXAGON: 68-1660-40; (72962)		EA	REF							REF	REF		A8A4K6H2
P-D		SCREW, MACHINE: P330-2291-000; (77250)		EA	2							REF	REF		A8A4K6H3
P-D		SCREW, MACHINE: P330-2291-000; (77250)		EA	REF							REF	REF		A8A4K6H4
P-D	5310-782-1349	WASHER, FLAT: 310-0045-000; (79807)		EA	1							REF	REF		A8A4K6H5
P-D	5945-889-1179	RELAY, ARMATURE: RB1J26D1018; (73905)		EA	1							*	*		A8A4K101
P-D	5945-153-8304	RELAY, ARMATURE: BRX300D2S2-26V; (09026)		EA	1										A8A4K2

SECTION II

TM 11-5820-509-35

REPAIR PARTS FOR DIRECT SUPPORT, GENERAL SUPPORT, AND DEPOT MAINTENANCE (Continued)															
(1) SMR CODE	(2) FEDERAL STOCK NUMBER	(3) DESCRIPTION Reference Number & Mfr. Code Usable on Code		(4) UNIT OF MEAS	(5) QTY INC IN UNIT	(6) 30 DAY DS MAINTENANCE ALLOWANCE			(7) 30 DAY GS MAINTENANCE ALLOWANCE			(8) 1 YR ALW PER 100 EQUIP CNTGCTY	(9) DEPOT MAINT ALW PER 100 EQUIP	(10) ILLUSTRATION	
						(a)	(b)	(c)	(a)	(b)	(c)			(a) FIG NO.	(b) ITEM NO. OR REFERENCE DESIGNATION
						1-20	21-50	51-100	1-20	21-50	51-100				
P-D	5310-262-6105	NUT, PLAIN, HEXAGON: P313-0045-000; (77250)		EA	2							REF	REF		A8A4K2H1
P-D	5310-262-6105	NUT, PLAIN, HEXAGON: P313-0045-000; (77250)		EA	REF							REF	REF		A8A4K2H2
P-D	5305-763-6963	SCREW, MACHINE: MS51959-28; (96906)		EA	2							REF	REF		A8A4K2H3
P-D	5305-763-6963	SCREW, MACHINE: MS51959-28; (96906)		EA	REF							REF	REF		A8A4K2H4
P-D	5310-271-7446	WASHER, LOCK, SPLIT: 310-0071-000; (79807)		EA	2							REF	REF		A8A4K2H5
P-D	5310-271-7446	WASHER, LOCK, SPLIT: 310-0071-000; (79807)		EA	REF							REF	REF		A8A4K2H6
P-D	5945-983-9145	RELAY, ARMATURE: 3SAF1242; (01526)		EA	4							*	*	3-67	A8A4K1
P-D	5310-614-3500	NUT, SELF-LOCKING, HEXAGON: 68-1660-40; (72962)		EA	2							REF	REF		A8A4K1H1
P-D	5310-614-3500	NUT, SELF-LOCKING, HEXAGON: 68-1660-40; (72962)		EA	REF							REF	REF		A8A4K1H2
P-D	5305-059-7189	SCREW, MACHINE: P330-2292-000; (77250)		EA	2							REF	REF		A8A4K1H3
P-D	5305-059-7189	SCREW, MACHINE: P330-2292-000; (77250)		EA	REF							REF	REF		A8A4K1H4
P-D	5945-983-9145	RELAY, ARMATURE: 3SAF1242; (01526)		EA	REF							REF	REF	3-67	A8A4K4
P-D	5310-614-3500	NUT, SELF-LOCKING, HEXAGON: 68-1660-40; (72962)		EA	2							REF	REF		A8A4K4H1
P-D	5310-614-3500	NUT, SELF-LOCKING, HEXAGON: 68-1660-40; (72962)		EA	REF							REF	REF		A8A4K4H2
P-D		SCREW, MACHINE: P330-2292-000; (77250)		EA	2							REF	REF		A8A4K4H3
P-D		SCREW, MACHINE: P330-2292-000; (77250)		EA	REF							REF	REF		A8A4K4H4
P-D	5945-983-9145	RELAY, ARMATURE: 3SAF1242; (01526)		EA	REF							REF	REF	3-67	A8A4K3
P-D	5310-614-3500	NUT, SELF-LOCKING, HEXAGON: 68-1660-40; (72962)		EA	2							REF	REF		A8A4K3H1
P-D	5310-614-3500	NUT, SELF-LOCKING, HEXAGON: 68-1660-40; (72962)		EA	REF							REF	REF		A8A4K3H2
P-D		SCREW, MACHINE: P330-2292-000; (77250)		EA	2							REF	REF		A8A4K3H3
P-D		SCREW, MACHINE: P330-2292-000; (77250)		EA	REF							REF	REF		A8A4K3H4
P-D	5945-983-9145	RELAY, ARMATURE: 3SAF1242; (01526)		EA	REF							REF	REF	3-67	A8A4K5
P-D	5305-054-5649	SCREW, MACHINE: MS51957-15; (96906)		EA	2							REF	REF		A8A4K5H1
P-D	5305-054-5649	SCREW, MACHINE: MS51957-15; (96906)		EA	REF							REF	REF		A8A4K5H2
P-D		WASHER, LOCK: MS35338-135; (96906)		EA	2							REF	REF		A8A4K5H3

SECTION II

TM 11-5820-509-35

REPAIR PARTS FOR DIRECT SUPPORT, GENERAL SUPPORT, AND DEPOT MAINTENANCE (Continued)															
(1) SMR CODE	(2) FEDERAL STOCK NUMBER	(3) DESCRIPTION Reference Number & Mfr. Code Usable on Code		(4) UNIT OF MEAS	(5) QTY INC IN UNIT	(6) 30 DAY DS MAINTENANCE ALLOWANCE			(7) 30 DAY GS MAINTENANCE ALLOWANCE			(8) 1 YR ALW PER 100 EQUIP CNTGCTY	(9) DEPOT MAINT ALW PER 100 EQUIP	(10) ILLUSTRATION	
						(a)	(b)	(c)	(a)	(b)	(c)			(a) FIG NO.	(b) ITEM NO. OR REFERENCE DESIGNATION
						1-20	21-50	51-100	1-20	21-50	51-100				
P-D		WASHER, LOCK: MS35338-135; (96906)		EA	REF							REF	REF		A8A4K5H4
P-D	5945-889-1180	RELAY, ARMATURE: 3SAC1025; (01526)		EA	1							*	*	3-65	A8A4K102
P-D	5310-275-0889	NUT, PLAIN, HEXAGON: P313-0132-000; (77250)		EA	2							REF	REF		A8A4K102H1
P-D	5310-275-0889	NUT, PLAIN, HEXAGON: P313-0132-000; (77250)		EA	REF							REF	REF		A8A4K102H2
P-D	5305-054-5647	SCREW, MACHINE: MS51957-13; (96906)		EA	2							REF	REF		A8A4K102H3
P-D	5305-054-5647	SCREW, MACHINE: MS51957-13; (96906)		EA	REF							REF	REF		A8A4K102H4
P-D	5310-058-2949	WASHER, LOCK: 310-0278-000; (70318)		EA	2							REF	REF		A8A4K102H5
P-D	5310-058-2949	WASHER, LOCK: 310-0278-000; (70318)		EA	REF							REF	REF		A8A4K102H6
P-D	5905-228-6088	RESISTOR, FIXED, COMPOSITION: RCR32G331K5; (81349)		EA	1							*	*		A8A4R9
P-D	5905-247-8732	RESISTOR, FIXED COMPOSITION: RCR32G471K5; (81349)		EA	1							*	*		A8A4R120
P-D	5905-104-8355	RESISTOR, FIXED, COMPOSITION RCR32G561K5; (81349)		EA	1							*	*		A8A4R125
P-D		RESISTOR, FIXED, COMPOSITION RCR32G153K5; (81349)		EA	2							*	*		A8A4R24
P-D		RESISTOR, FIXED, COMPOSITION RCR32G153K5; (81349)		EA	REF							REF	REF		A8A4R25
P-D	5905-484-0278	RESISTOR, FIXED, COMPOSITION RCR32G335K5; (81349)		EA	3							*	*	3-64	A8A4R112
P-D	5905-484-0278	RESISTOR, FIXED, COMPOSITION RCR32G335K5; (81349)		EA	REF							REF	REF	3-64	A8A4R113
P-D	5905-484-0278	RESISTOR, FIXED, COMPOSITION RCR32G335K5; (81349)		EA	REF							REF	REF	3-64	A8A4R114
P-D		RESISTOR, FIXED, COMPOSITION RC42GF181K; (81349)		EA	1							*	*		A8A4R6
P-D		RESISTOR, FIXED, COMPOSITION RC42CF331K; (81349)		EA	1							*	*		A8A4R10
P-D	5905-988-2313	RESISTOR, FIXED, FILM RN60D1211F; (81349)		EA	1							*	*	3-67	A8A4R127
P-D	5905-985-5465	RESISTOR, FIXED, FILM RN60D1962F; (81349)		EA	1							REF	REF	3-67	A8A4R126
P-D	5905-952-9232	RESISTOR, FIXED, WIREWOUND RE70G4751; (81349)		EA	1							*	*	3-67	A8A4R8
P-D	5310-614-3500	NUT, SELF-LOCKING, HEXAGON 68-1660-40; (72962)		EA	2							REF	REF		A8A4R8H1
P-D	5310-614-3500	NUT, SELF-LOCKING, HEXAGON 68-1660-40; (72962)		EA	REF							REF	REF		A8A4R8H2
P-D	5305-801-9932	SCREW, MACHINE P330-2291-000; (77250)		EA	2							REF	REF		A8A4R8H3
P-D	5305-801-9932	SCREW, MACHINE P330-2291-000; (77250)		EA	REF							REF	REF		A8A4R8H4

SECTION II

TM 11-5820-509-35

REPAIR PARTS FOR DIRECT SUPPORT, GENERAL SUPPORT, AND DEPOT MAINTENANCE (Continued)															
(1) SMR CODE	(2) FEDERAL STOCK NUMBER	(3) DESCRIPTION Reference Number & Mfr. Code Usable on Code		(4) UNIT OF MEAS	(5) QTY INC IN UNIT	(6) 30 DAY DS MAINTENANCE ALLOWANCE			(7) 30 DAY GS MAINTENANCE ALLOWANCE			(8) 1 YR ALW PER 100 EQUIP CNTGCTY	(9) DEPOT MAINT ALW PER 100 EQUIP	(10) ILLUSTRATION	
						(a)	(b)	(c)	(a)	(b)	(c)			(a)	(b)
						1-20	21-50	51-100	1-20	21-50	51-100			FIG NO.	ITEM NO. OR REFERENCE DESIGNATION
P-H-T	5820-977-1566	RESISTOR-SWITCH ASSEMBLY: 549-6229-003; (13499)		EA	1				*	*	*	*	*		A8A4A7
P-D		BOOT, DUST AND MOISTURE SEAL: R9030-1-4; (97539)		EA	1							*	*		A8A4A7H1
P-D	5310-167-0837	WASHER: AN960-616L; (88044)		EA	1							*	*		A8A4A7H2
X1-D		RESISTOR, FIXED COMPOSITION: RCRO20G102KS; (81349)		EA	1										A8A4A7R118
X1-D		RESISTOR, FIXED, COMPOSITION: RCR32G104KS; (81349)		EA	1										A8A4A7R107
X1-D		RESISTOR, FIXED, COMPOSITION: RC42GF104K; (81349)		EA	3										A8A4A7R105
X1-D		RESISTOR, FIXED, COMPOSITION: RC42GF104K; (81349)		EA	REF										A8A4A7R106
X1-D		RESISTOR, FIXED, COMPOSITION: RC42GF104K; (81349)		EA	REF										A8A4A7R128
X1-D		RESISTOR-SWITCH SUBASSEMBLY: 549-6194-002; (13499)		EA	1										A8A4A7A1
X1-D		WASHER, FLAT: 310-0045-000; (79807)		EA	4										A8A4A7A1H1
X1-D		NUT, PLAIN, HEXAGON: P313-0132-000; (77250)		EA	4										A8A4A7A1H2
X1-D		BOARD, TERMINAL, RIVETED: 549-6193-002; (13499)		EA	1										A8A4A7A1E1
X1-D		CAPACITOR, FIXED, CERAMIC: 20C95; (56289)		EA	1										A8A4A7A1C106
X1-D		CAPACITOR, FIXED, CERAMIC: CK13BX103M; (81349)		EA	1										A8A4A7A1C107
X1-D		RESISTOR, FIXED, COMPOSITION: RCR20G47LKS; (81349)		EA	1										A8A4A7A1R129
X1-D		RESISTOR, VARIABLE, COMPOSITION: G3629; (01121)		EA	1								3-65		A8A4A7A1R117
X1-D		NUT, PLAIN, HEXAGON: P334-0253-00; (77250)		EA	1										A8A4A7A1R117H1
X1-D		WASHER, LOCK: 1714-05; (78189)		EA	1										A8A4A7A1R117H2
X1-D		SEMICONDUCTOR DEVICE, DIODE: IM3287; (07688)		EA	1										A8A4A7A1CR103
X1-D		SEMICONDUCTOR DEVICE, DIODE: JAN1N663; (81350)		EA	1										A8A4A7A1CR102
X1-D		SHAFT, SHOULDERED-RESISTOR: 549-6191-002; (13499)		EA	1										A8A4A7MP1
X1-D		SWITCH, ROTARY: 225251N2C; (76854)		EA	1										A8A4A7S103
P-D		RESISTOR, VARIABLE, WIRE WOUND: 44968-50; (44655)		EA	1							*	*	3-65	A8A4R121
P-D		NUT, PLAIN, HEXAGON: P334-0253-00; (77250)		EA	1							*	*		A8A4R121H1
P-D		WASHER, SPRING, TENSION: 310-0082-000; (79807)		EA	1							*	*		A8A4R121H2

REPAIR PARTS FOR DIRECT SUPPORT, GENERAL SUPPORT, AND DEPOT MAINTENANCE (Continued)															
(1) SMR CODE	(2) FEDERAL STOCK NUMBER	(3) DESCRIPTION Reference Number & Mfr. Code Usable on Code		(4) UNIT OF MEAS	(5) QTY INC IN UNIT	(6) 30 DAY DS MAINTENANCE ALLOWANCE			(7) 30 DAY GS MAINTENANCE ALLOWANCE			(8) 1 YR ALW PER 100 EQUIP CNTGCTY	(9) DEPOT MAINT ALW PER 100 EQUIP	(10) ILLUSTRATION	
						(a)	(b)	(c)	(a)	(b)	(c)			(a) FIG NO.	(b) ITEM NO. OR REFERENCE DESIGNATION
						1-20	21-50	51-100	1-20	21-50	51-100				
P-D	5340-598-1300	RING, RETAINING: 5133-25C; (79136)		EA	2							*	*		A8A4H1
P-D	5340-598-1300	RING, RETAINING: 5133-25C; (79136)		EA	REF							REF	REF		A8A4H2
P-D	5340-205-6694	RING, RETAINING: 5133-6C; (79136)		EA	4							*	*		A8A4H3
P-D	5340-205-6694	RING, RETAINING: 5133-6C; (79136)		EA	REF							REF	REF		A8A4H4
P-D	5340-205-6694	RING, RETAINING: 5133-6C; (79136)		EA	REF							REF	REF		A8A4H5
P-D	5340-205-6694	RING, RETAINING: 5133-6C; (79136)		EA	REF							REF	REF		A8A4H6
P-D	5820-984-2139	SEMICONDUCTOR DEVICE-RESISTOR ASSEMBLY: 549-6126-002; (13499)		EA	1							*	*		A8A4A15
P-D		WASHER, FLAT: 310-6325-000; (79807)		EA	2							REF	REF		A8A4A15H2
P-D		WASHER, LOCK, SPRING: MS35338-135; (96906)		EA	2							REF	REF		A8A4A15H2
P-D	5305-054-5649	SCREW, MACHINE: MS51957-15; (96906)		EA	2							REF	REF		A8A4A15H2
X1-D		BOARD, TERMINAL, NO. 2-PRESSED: 549-6205-003; (13499)		EA	1										A8A4A15E1
X1-D		RESISTOR, FIXED, COMPOSITION: RCR20G472KS; (81349)		EA	1										A8A4A15R16
X1-D		SEMICONDUCTOR DEVICE, DIODE: 1N3639; (07688)		EA	4										A8A4A15CR3
X1-D		SEMICONDUCTOR DEVICE, DIODE: 1N3639; (07688)		EA	REF										A8A4A15CR4
X1-D		SEMICONDUCTOR DEVICE, DIODE: 1N3639; (07688)		EA	REF										A8A4A15CR5
X1-D		SEMICONDUCTOR DEVICE, DIODE: 1N3639; (07688)		EA	REF										A8A4A15CR6
M-D		SHAFT, SHOULDERED-SWITCH: 549-6195-002; (13499)		EA	1										A8A4MP60
M-D	5340-695-2558	SLEEVE, SPRING: 340-0642-00; (91314)		EA	21										A8A4MP61
P-D	5305-922-6281	SCREW, MACHINE: P347-005-000; (77250)		EA	1							*	*		A8A4MP61H1
P-D	5310-933-8119	WASHER, LOCK, SPLIT: MS35338-137; (96906)		EA	1							REF	REF		A8A4MP61H2
M-D	5340-695-2558	SLEEVE, SPRING: 340-0642-00; (91314)		EA	REF										A8A4MP62
P-D	5305-660-2196	SCREW, MACHINE: P347-0056-000; (77250)		EA	1							REF	REF		A8A4MP62H1
P-D	5310-933-8119	WASHER, LOCK, SPLIT: MS35338-137; (96906)		EA	1							REF	REF		A8A4MP62H2
M-D	5340-695-2558	SLEEVE, SPRING: 340-0642-00; (91314)		EA	REF										A8A4MP63
P-D	5305-660-2196	SCREW, MACHINE: P347-0056-000; (77250)		EA	1							REF	REF		A8A4MP63H1

SECTION II

TM 11-5820-509-35

REPAIR PARTS FOR DIRECT SUPPORT, GENERAL SUPPORT, AND DEPOT MAINTENANCE (Continued)															
(1) SMR CODE	(2) FEDERAL STOCK NUMBER	(3) DESCRIPTION Reference Number & Mfr. Code Usable on Code		(4) UNIT OF MEAS	(5) QTY INC IN UNIT	(6) 30 DAY DS MAINTENANCE ALLOWANCE			(7) 30 DAY GS MAINTENANCE ALLOWANCE			(8) 1 YR ALW PER 100 EQUIP CNTGCTY	(9) DEPOT MAINT ALW PER 100 EQUIP	(10) ILLUSTRATION	
						(a)	(b)	(c)	(a)	(b)	(c)			(a) FIG NO.	(b) ITEM NO. OR REFERENCE DESIGNATION
						1-20	21-50	51-100	1-20	21-50	51-100				
P-D	5310-933-8119	WASHER, LOCK, SPLIT: MS35338-137; (96906)		EA	1							REF	REF		A8A4MP63H2
M-D	5340-695-2558	SLEEVE, SPRING: 340-0662-00; (91314)		EA	REF										A8A4MP64
P-D		SCREW, MACHINE: P347-0056-000; (77250)		EA	1							REF	REF		A8A4MP64H1
P-D	5310-933-8119	WASHER, LOCK, SPLIT: MS35338-137; (96906)		EA	1							REF	REF		A8A4MP64H2
M-D	5340-695-2558	SLEEVE, SPRING: 340-0642-00; (91314)		EA	REF										A8A4MP65
P-D		SCREW, MACHINE: P347-0056-000; (77250)		EA	1							REF	REF		A8A4MP65H1
P-D	5310-933-8119	WASHER, LOCK, SPLIT: MS35338-137; (96906)		EA	1							REF	REF		A8A4MP65H2
M-D	5340-695-2558	SLEEVE, SPRING: 340-0642-00; (91314)		EA	REF										A8A4MP66
P-D		SCREW, MACHINE: P347-0056-000; (77250)		EA	1							REF	REF		A8A4MP66H1
P-D	5310-933-8119	WASHER, LOCK, SPLIT: MS35338-137; (96906)		EA	1							REF	REF		A8A4MP66H2
M-D	5340-695-2558	SLEEVE, SPRING: 340-0642-00; (9131)		EA	REF										A8A4MP67
P-D		SCREW, MACHINE: P347-0056-000; (77250)		EA	1							REF	REF		A8A4MP67H1
P-D	5310-933-8119	WASHER, LOCK, SPLIT: MS35338-137; (96906)		EA	1							REF	REF		A8A4MP67H2
M-D	5340-695-2558	SLEEVE, SPRING: 3k0-0642-00; (91314)		EA	REF										A8A4MP68
P-D		SCREW, MACHINE: P347-0056-000; (77250)		E,	1							REF	REF		A8A4MP68H1
P-D	5310-933-8119	WASHER, LOCK, SPLIT: MS35338-137; (9690 6)		EA	1							REF	REF		A8A4MP68H2
M-D	5310-695-2558	SLEEVE, SPRING: 340-0642-00; (91314)		EA	REF										A8A4MP69
P-D		SCREW, MACHINE: P347-0056-000; (77250)		EA	1							REF	REF		A8A4MP69H1
P-D	5310-933-8119	WASHER, LOCK, SPLIT: MS35338-137; (96906)		EA	1							REF	REF		A8A4MP69H2
M-D	5340-695-2558	SLEEVE, SPRING: 340-0642-00; (91314)		EA	REF										A8A4MP70
P-D		SCREW, MACHINE: P347-0056-000; (77250)		EA	1							REF	REF		A8A4MP70H1
P-D	5310-933-8119	WASHER, LOCK, SPLIT: MS35338-137; (96906)		EA	1							REF	REF		A8A4MP70H2
M-D	5310-695-2558	SLEEVE, SPRING: 340-0642-00; (91314)		EA	REF										A8A4MP71
P-D		SCREW, MACHINE: P347-0056-000; (77250)		EA	1							REF	REF		A8A4MP71H1
P-D	5310-933-8119	WASHER, LOCK, SPLIT: MS35338-137; (96906)		EA	1							REF	REF		A8A4MP71H2

SECTION II

TM 11-5820-509-35

REPAIR PARTS FOR DIRECT SUPPORT, GENERAL SUPPORT, AND DEPOT MAINTENANCE (Continued)															
(1) SMR CODE	(2) FEDERAL STOCK NUMBER	(3) DESCRIPTION Reference Number & Mfr. Code Usable on Code		(4) UNIT OF MEAS	(5) QTY INC IN UNIT	(6) 30 DAY DS MAINTENANCE ALLOWANCE			(7) 30 DAY GS MAINTENANCE ALLOWANCE			(8) 1 YR ALW PER 100 EQUIP CNTGCTY	(9) DEPOT MAINT ALW PER 100 EQUIP	(10) ILLUSTRATION	
						(a)	(b)	(c)	(a)	(b)	(c)			(a) FIG NO.	(b) ITEM NO. OR REFERENCE DESIGNATION
						1-20	21-50	51-100	1-20	21-50	51-100				
M-D	5340-695-2558	SLEEVE, SPRING: 340-0612-00; (91314)		EA	REF										A8A4MP72
P-D	5305-660-2196	SCREW, MACHINE: P347-0056-000; (77250)		EA	1							REF	REF		A8A4MP72H1
P-D	5310-933-8119	WASHER, LOCK, SPLIT: MS35338-137; (96906)		EA	1							REF	REF		A8A4MP72H2
M-D	5340-695-2558	SLEEVE, SPRING: 340-0642-00; (91314)		EA	REF										A8A4MP73
P-D	5305-660-2196	SCREW, MACHINE: P347-0056--00; (77250)		EA	1							REF	REF		A8A4MP73H1
P-D	5310-933-8119	WASHER, LOCK, SPLIT MS35338-137; (96906)		EA	1							REF	REF		A8A4MP73H2
M-D	5340-695-2558	SLEEVE SPRING: 340-0642-00; (91314)		EA	REF										A8A4MP74
P-D	5305-660-2196	SCREW, MACHINE: P347-0056-000; (77250)		EA	1							REF	REF		A8A4MP74H1
P-D	5310-933-8119	WASHER, LOCK, SPLIT: MS35338-137; (96906)		EA	1							REF	REF		A8A4MP74H2
M-D	5340-695-2558	SLEEVE, SPRING 340-0642-00; (91314)		EA	REF										A8A4MP75
P-D	5305-660-2196	SCREW, MACHINE: P347-0056-000; (77250)		EA	1							REF	REF		A8A4MP75H1
P-D	5310-933-8119	WASHER, LOCK, SPLIT: MS35338-137; (96906)		EA	1							REF	REF		A8A4MP75H2
M-D	5340-695-2558	SLEEVE, SPRING: 340-0642-00; (91314)		EA	REF										A8A4MP76
P-D	5305-660-2196	SCREW, MACHINE: P347-0056-000; (7 7250)		EA	1							REF	REF		A8A4MP76H1
P-D	5310-933-8119	WASHER, LOCK, SPLIT: MS35338-137; (96906)		EA	1							REF	REF		A8A4MP76H2
M-D	5340-695-2558	SLEEVE, SPRING: 340-0642-00; (91314)		EA	REF										A8A4MP77
P-D	5305-660-2196	SCREW, MACHINE: P37-0056-000; (77250)		EA	1							REF	REF		A8A4MP77H1
P-D	5310-933-8119	WASHER, LOCK, SPLIT: MS35338-137; (96906)		EA	1							REF	REF		A8A4MP77H2
M-D	5340-695-2558	SLEEVE, SPRING: 340-0642-00; (91314)		EA	REF										A8A4MP78
P-D	5305-660-2196	SCREW, MACHINE: P347-0056-000; (77250)		EA	1							REF	REF		A8A4MP78H1
P-D	5310-933-8119	WASHER, LOCK, SPLIT: MS35338-137; (96906)		EA	1							REF	REF		A8A4MP78H2
K-D	5340-695-2558	SLEEVE, SPRING: 340-0642-00; (91314)		EA	REF										A8A4MP79
P-D	5305-660-2196	SCREW , MACHINE: P347-0056-000; (77250)		EA	1							REF	REF		A8A4MP79H1
P-D	5310-933-8119	WASHER. LOCK, SPLIT: MS35338-137; (96906)		EA	1							REF	REF		A8A4MP79H2
M-D	5340-695-2558	SLEEVE, SPRING: 340-0642-00; (91314)		EA	REF										A8A4MP80

SECTION II

TM 11-5820-509-35

REPAIR PARTS FOR DIRECT SUPPORT, GENERAL SUPPORT, AND DEPOT MAINTENANCE (Continued)															
(1) SMR CODE	(2) FEDERAL STOCK NUMBER	(3) DESCRIPTION Reference Number & Mfr. Code Usable on Code		(4) UNIT OF MEAS	(5) QTY INC IN UNIT	(6) 30 DAY DS MAINTENANCE ALLOWANCE			(7) 30 DAY GS MAINTENANCE ALLOWANCE			(8) 1 YR ALW PER 100 EQUIP CNTGCTY	(9) DEPOT MAINT ALW PER 100 EQUIP	(10) ILLUSTRATION	
						(a)	(b)	(c)	(a)	(b)	(c)			(a) FIG NO.	(b) ITEM NO. OR REFERENCE DESIGNATION
						1-20	21-50	51-100	1-20	21-50	51-100				
P-D	5305-660-2196	SCREW, MACHINE: P347-0056-000; (77250)		EA	1							REF	REF		A8A4MP80H1
P-D	5310-933-8119	WASHER, LOCK, SPLIT: MS35338-137; (96906)		EA	1							REF	REF		A8A4MP80H2
M-D	5340-695-2558	SLEEVE, SPRING: 3400-062-00; (91314)		EA	REF										A8A4MP81
P-D	5305-660-2196	SCREW, MACHINE: P347-0056-000; (77250)		EA	1							REF	REF		A8A4MP81H1
P-D	5310-933-8119	WASHER, LOCK, SPLIT: MS35338-137; (96906)		EA	1							REF	REF		A8A4MP81H2
P-D	5940-056-8696	SOLDER, SLEEVE: D144-01; (08795)		EA	2							*	*		A8A4MP82
P-D	5940-056-8696	SOLDER, SLEEVE: D144-01; (08795)		EA	REF							REF	REF		A8A4MP83
M-D		SPACER, PLATE-RELAY: 549-6149-002; (13499)		EA	1										A8A4MP84
M-D		SPACER, SLEEVE: 541-6017-002; (13499)		EA	6										A8A4MP85
M-D		SPACER, SLEEVE: 541-6017-002; (13499)		EA	REF										A8A4MP85A
M-D		SPACER, SLEEVE: 541-6017-002; (13499)		EA	REF										A8A4MP86
M-D		SPACER, SLEEVE: 541-6017-002; (13499)		EA	REF										A8A4MP87
M-D		SPACER, SLEEVE: 541-6017-002; (13499)		EA	REF										A8A4MP88
M-D		SPACER, SLEEVE: 541-6017-002; (13499)		EA	REF										A8A4MP89
P-D	5820-984-1798	SPRING ASSEMBLY: 549-6102-002; (13499)		EA	2							*	*		A8A4MP90
P-D		SCREW, MACHINE: P342-0165-000; (77250)		EA	2							REF	REF		A8A4MP90H1
P-D		SCREW, MACHINE: P342-0165-000; (77250)		EA	REF							REF	REF		A8A4MP90H2
P-D	5820-984-1798	SPRING SUBASSEMBLY: 549-6102-002; (13499)		EA	REF							REP	REF		A8A4MP91
P-D		SCREW, MACHINE: P342-0165-000; (77250)		EA	2							REF	REF		A8A4MP91H1
P-D		SCREW, MACHINE: P342-0165-000; (77250)		EA	REF							REF	REF		A8A4MP91H2
M-D	5841-514-2298	SPRING, HELICAL COMPRESSION: 340-0127-000; (91314)		EA	4										A8A4MP92
M-D	5841-514-2298	SPRING, HELICAL COMPRESSION: 340-0127-000; (91314)		EA	REF										A8A4MP93
M-D	5841-514-2298	SPRING, HELICAL COMPRESSION: 340-0127-000; (91314)		EA	REF										A8A4MP94
M-D	5841-514-2298	SPRING, HELICAL COMPRESSION: 340-0127-000; (91314)		EA	REF										A8A4MP95
P-D	5930-999-9195	SWITCH, PUSH: PM6; (04009)		EA	1							*	*		A8A483

SECTION II

TM 11-5820-509-35

REPAIR PARTS FOR DIRECT SUPPORT, GENERAL SUPPORT, AND DEPOT MAINTENANCE (Continued)															
(1) SMR CODE	(2) FEDERAL STOCK NUMBER	(3) DESCRIPTION Reference Number & Mfr. Code Usable on Code		(4) UNIT OF MEAS	(5) QTY INC IN UNIT	(6) 30 DAY DS MAINTENANCE ALLOWANCE			(7) 30 DAY GS MAINTENANCE ALLOWANCE			(8) 1 YR ALW PER 100 EQUIP CNTGCTY	(9) DEPOT MAINT ALW PER 100 EQUIP	(10) ILLUSTRATION	
						(a)	(b)	(c)	(a)	(b)	(c)			(a) FIG NO.	(b) ITEM NO. OR REFERENCE DESIGNATION
						1-20	21-50	51-100	1-20	21-50	51-100				
P-D	5930-893-1928	BOX, MINIATURE PUSH-BUTTON: N5040R, (97539)		EA	1							*	*		A8A4S3H1
P-D		WASHER: 500-1065-003, (13499)		EA	1							*	*		A8A4S3H2
P-D	5930-981-5868	SWITCH, ROTARY: 213923FIX; (76854)		EA	1							*	*		A8A4S1
P-D	5975-987-8829	BOOT, DUST AND .MOISTURE SEAL: N9033-1-4, (97539)		EA	1							REF	REF		A8A4S1H1
P-H-T	5820-104-9512	SWITCH, ROTARY: 549-6232-004; (13499)		EA	1				*	*	*	*	*		A8A4A16
P-D	5310-275-0889	NUT, PLAIN, HEXAGON: P313-0132-000, (77250)		EA	2							REF	REF		A8A4A16H2
P-D		NUT, PLAIN, HEXAGON: P313-0156-000, (77250)		EA	2							REF	REF		A8A4A16H2
P-D	5305-719-5064	SCREW, MACHINE: MS51959-30; (96906)		EA	2							REF	REF		A8A4A16H2
P-D	5305-938-4044	SCREW, MACHINE: P342-0152-000; (T7250)		EA	1							REF	REF		A8A4A16H1
P-D	5305-801-9932	SCREW, MACHINE: P330-2291-000; (77250)		EA	2							REF	REF		A8A4A16H2
P-D	5305-151-1320	SCREW, MACHINE: P342-0153-000; (77250)		EA	1							*	*		A8A4A16H1
P-D	5310-782-1349	WASHER, FLAT: 310-0045-000, (79807)		EA	REF							REF	REF		A8A4A16H2
P-D	5310-591-3416	WASHER, FLAT: 310-0054-000; (79807)		EA	2							*	*		A8A4A16H2
P-D	5310-058-2949	WASHER, LOCK: 310-0278-000; (70318)		EA	2							REF	REF		A8A4A16H2
P-D	5310-685-1971	WASHER, SPRING TENSION: 310-0396-00; (70807)		EA	2							REF	REF		A8A4A16H2
X1-D		BOARD, TERMINAL, PRESSED: 549-6223-003- (13499)		EA	1										A8A4A16E1
X1-D		CAPACITOR, FIXED, CERAMIC: 850S100N; (71590)		EA	1									3-64	A8A4A16C115
X1-D		SCREW, MACHINE: P343-0328-000; (77250)		EA	1										A8A4A16C115H1
X1-D		WASHER, LOCK: 310-0078-000; (79807)		EA	1										A8A4A16C115H2
X1-D		CAPACITOR, FIXED, CERAMIC: 850S50Z, (71590)		EA	2									3-64	A8A4A16C116
X1-D		SCREW, MACHINE: P343-0328-000; (77250)		EA	1										A8A4A16C116H1
X1-D		WASHER, LOCK: 310-0078-000; (79807)		EA	1										A8A4A16C116H2
X1-D		CAPACITOR, FIXED, CERAMIC: 850S50Z; (71590)		EA	REF									3-64	A8A4A16C117
X1-D		SCREW, MACHINE: P343-0328-000, (77250)		EA	1										A8A4A16C117H1
X1-D		WASHER, LOCK: 310-0078-000; (79807)		EA	1										A8A4A16C117H2

SECTION II

TM 11-5820-509-35

REPAIR PARTS FOR DIRECT SUPPORT, GENERAL SUPPORT, AND DEPOT MAINTENANCE (Continued)															
(1) SMR CODE	(2) FEDERAL STOCK NUMBER	(3) DESCRIPTION Reference Number & Mfr. Code Usable on Code		(4) UNIT OF MEAS	(5) QTY INC IN UNIT	(6) 30 DAY DS MAINTENANCE ALLOWANCE			(7) 30 DAY GS MAINTENANCE ALLOWANCE			(8) 1 YR ALW PER 100 EQUIP CNTGCTY	(9) DEPOT MAINT ALW PER 100 EQUIP	(10) ILLUSTRATION	
						(a)	(b)	(c)	(a)	(b)	(c)			(a) FIG NO.	(b) ITEM NO. OR REFERENCE DESIGNATION
						1-20	21-50	51-100	1-20	21-50	51-100				
X1-D		CAPACITOR, FIXED, CERAMIC: 850S40Z; (71590)		EA	1									3-64	A8A4A16C118
X1-D		SCREW, MACHINE: P343-0328-000; (77250)		EA	1										A8A4A16C118H1
X1-D		WASHER, LOCK: 310-0078-000; (79807)		EA	1										A8A4A16C118H2
X1-D		CAPACITOR, FIXED, CERAMIC: 850S20Z; (71590)		EA	3									3-64	A8A4A16C118
X1-D		SCREW, MACHINE: P343-0328-000; (77250)		EA	1										A8A4A16C119H1
X1-D		WASHER, LOCK: 310-0078-000; (79807)		EA	1										A8A4A16C119H2
X1-D		CAPACITOR, FIXED, CERAMIC: 850520Z; (71590)		EA	REF									3-64	A8A4A16C120
X1-D		SCREW, MACHINE: P343-0328-000; (77250)		EA	1										A8A4A16C120H1
X1-D		WASHER, LOCK: 310-0078-000; (79807)		EA	1										A8A4A16C120H2
X1-D		CAPACITOR, FIXED, CERAMIC: 850200Z; (71590)		EA	REF									3-64	A8A4A16C121
X1-D		SCREW, MACHINE: P343-0328-000; (77250)		EA	1										A8A4A16C121H1
X1-D		WASHER, LOCK: 310-0078-000; (79807)		EA	1										A8A4A16C121H2
X1-D		CAPACITOR, FIXED, CERAMIC: AG5-1-1-2Z; (00656)		EA	1									3-64	A8A4A16C105
X1-D		CAPACITOR, FIXED, CERAMIC: 2DHT55T209CAA; (71590)		EA	1									3-64	A8A4A16C124
X1-D		CAPACITOR, FIXED, CERAMIC: HTS17-3000Z; (00656)		EA	1									3-64	A8A4A16C144
X1-D		CAPACITOR, FIXED, MICA: MHW5455E151JQ; (00853)		EA	5									3-64	A8A4A16C109
X1-D		SCREW, MACHINE: P343-0382-000; (77250)		EA	1										A8A4A16C109H1
X1-D		WASHER, LOCK: 310-0395-00; (79807)		EA	1										A8A4A16C109H2
X1-D		CAPACITOR, FIXED, MICA: MHW5555E151JQ; (00853)		EA	REF									3-64	A8A4A16C111
X1-D		SCREW, MACHINE: P343-0382-000; (77250)		EA	1										A8A4A16C111H1
X1-D		WASHER, LOCK 310-0395-00; (79807)		EA	1										A8A4A16C111H2
X1-D		CAPACITOR, FIXED, MICA MRW5455E151JQ; (00853)		EA	REF									3-64	A8A4A16C112
X1-D		SCREW, MACHINE P343-0382-000; (77250)		EA	1										A8A4A16C112H1
X1-D		WASHER, LOCK 310-0395-00; (7 9807)		EA	1										A8A4A16C112H2
X1-D		CAPACITOR, FIXED, MICA MHWS55E151JQ; (00853)		EA	REF									3-64	A8A4A16C113

SECTION II

TM 11-5820-509-35

REPAIR PARTS FOR DIRECT SUPPORT, GENERAL SUPPORT, AND DEPOT MAINTENANCE (Continued)															
(1) SMR CODE	(2) FEDERAL STOCK NUMBER	(3) DESCRIPTION Reference Number & Mfr. Code Usable on Code		(4) UNIT OF MEAS	(5) QTY INC IN UNIT	(6) 30 DAY DS MAINTENANCE ALLOWANCE			(7) 30 DAY GS MAINTENANCE ALLOWANCE			(8) 1 YR ALW PER 100 EQUIP CNTGCTY	(9) DEPOT MAINT ALW PER 100 EQUIP	(10) ILLUSTRATION	
						(a)	(b)	(c)	(a)	(b)	(c)			(a) FIG NO.	(b) ITEM NO. OR REFERENCE DESIGNATION
						1-20	21-50	51-100	1-20	21-50	51-100				
X1-D		SCREW, MACHINE: P343-0382-000; (77250)		EA	1										A8A4A16C113H1
X1-D		WASHER, LOCK: 310-0395-00; (79807)		EA	1										A8A4A16C113H2
X1-D		CAPACITOR, FIXED, MICA: MHWS55E1S1JQ; (00853)		EA	REF								3-64		A8A4A16C114
X1-D		SCREW, MACHINE: P343-0382-000; (T7250)		EA	1										A8A4A16C114H1
X1-D		WASHER, LOCK: 310-0395-00; (7980 7)		EA	1										A8A4A16C114H2
X1-D		CAPACITOR, FIXED, MICA: MHWS5455E5S1JQ; (00853)		EA	2								3-64		A8A4A16C108
X1-D		SCREW, MACHINE: P343-0382-000; (77250)		EA	1										A8A4A16C108H1
X1-D		WASHER, LOCK: 310-0395-00; (79807)		EA	1										A8A4A16C108H2
X1-D		CAPACITOR, FIXED, MICA: MHW5455E501JQ; (00853)		EA	REF								3-64		A8A4A16C110
X1-D		SCREW, MACHINE: P343-0382-000; (77250)		EA	1										A8A4A16C110H1
X1-D		WASHER, LOCK: 310-0395-00; (79807)		EA	1										A8A4A16C110H2
X1-D		CAP. PLATE: SA91; (07886)		EA	1										A8A4A16MP1
X1-D		DEFLECTOR, AIR, ROLLED: 553-2413-003; (13499)		EA	1										A8ARA16MP2
X1-D		POST, ELECTRICAL-MECHANICAL: 540-9223-003; (13499)		EA	2										A8A4A16MP3
X1-D		POST, ELECTRICAL-MECHANICAL: 540-9223-003; (13499)		EA	REF										A8A4A16MP4
X1-D		POST, ELECTRICAL-MECHANICAL: 540-9229-003; (13499)		E1	2										A8A4A16MP5
X1-D		WASHER, NONMETALLIC: 302-0024-000; (052b8)		EA	1										A8A4A16MP5H1
X1-D		POST, ELECTRICAL-MECHANICAL: 540-9229-003; (13499)		EA	REF										A8A4A16MP6
X1-D		WASHER, NONMETALLIC: 302-0024-000; (05284)		EA	1										A8A4A16MP6H1
X1-D		RETAINER, CAPACITOR. 549-6197-002; (13499)		EA	1										A8A4A16MP7
X1-D		SCREW, MACHINE P343-0330-000; (77250)		EA	2										A8A4A16MP7H1
X1-D		SCREW, MACHINE P343-0330-000; (77250)		EA	REF										A8A4A16MP7H2
X1-D		WASHER, LOCK 310-0078-000; (79807)		EA	2										A8A4A16MP7H3
X1-D		WASHER, LOCK 310-0078-000; (79807)		EA	REF										A8A4A16MP7H4
X1-D		SPACER, SLEEVE 541-6038-002; (13499)		EA	2										A8A4A16MP8

SECTION II

TM 11-5820-509-35

REPAIR PARTS FOR DIRECT SUPPORT, GENERAL SUPPORT, AND DEPOT MAINTENANCE (Continued)															
(1) SMR CODE	(2) FEDERAL STOCK NUMBER	(3) DESCRIPTION Reference Number & Mfr. Code Usable on Code		(4) UNIT OF MEAS	(5) QTY INC IN UNIT	(6) 30 DAY DS MAINTENANCE ALLOWANCE			(7) 30 DAY GS MAINTENANCE ALLOWANCE			(8) 1 YR ALW PER 100 EQUIP CNTGCTY	(9) DEPOT MAINT ALW PER 100 EQUIP	(10) ILLUSTRATION	
						(a)	(b)	(c)	(a)	(b)	(c)			(a) FIG NO.	(b) ITEM NO. OR REFERENCE DESIGNATION
						1-20	21-50	51-100	1-20	21-50	51-100				
X1-D		STUD, CONTINUOUS THREAD: P312-0088-000; (77250)		EA	1										A8A4A16MP8H1
X1-D		WASHER, NONMETALLIC: 302-0024-000; (05284)		EA	1										A8A4A16MP8H2
X1-D		SPACER, SLEEVE: 541-6038-002; (13499)		EA	REF										A8A4A16MP9
X1-D		STUD, CONTINUOUS THREAD: P312-0088-000; (77250)		EA	1										A8A4A16MP9H1
X1-D		WASHER, NONMETALLIC: 302-002-000000; (05284)		EA	1										A8A4A16MP9H2
X1-D		SPACER, SLEEVE: 541-6039-002; (13499)		EA	2										A8A4A16P10
X1-D		WASHER, NONMETALLIC: 302-0024-000; (05284)		EA	2										A8A4A16MP10H1
X1-D		WASHER, NONMETALLIC: 302-002-000; (05284)		EA	REF										A8A4A16MP10H2
X1-D		SPACER, SLEEVE: 541-6039-002; (13499)		EA	REF										A8A4A16MP11
X1-D		WASHER, NONMETALLIC: 302-0024-000; (05284)		EA	2										A8A4A16MP11H1
X1-D		WASHER, NONMETALLIC: 302-0024-000; (05284)		EA	REF										A8A4A16MP11H2
X1-D		SUPPRESSER, PARASITIC: 549-6198-002; (13499)		EA	1								3-64		A8A4A16104-R110
X1-D		SWITCH SECTION, ROTARY, POWER: PA234-026; (71590)		EA	2								3-64		A8A4A16S101A
X1-D		SWITCH SECTION, ROTARY: PA234-026; (71590)		EA	REF								3-64		A8A4A16S101B
X1-D		TERMINAL, LUG: 2504-04-00-2220N; (78189)		EA	1										A8A4A16E2
X1-D		TERMINAL, LUG: 2104-06-02-2520N; (78189)		EA	7										A8A4A16E3
X1-D		SCREW, MACHINE: P343-0327-000; (77250)		EA	1										A8A4A16E3H1
X1-D		WASHER, LOCK: 1806-00; (78189)		EA	1										A8A4A16E3H2
X1-D		TERMINAL, LUG: 2104-06-02-2520; (78189)		EA	REF										A8A4A16E4
X1-D		SCREW, MACHINE: P343-0327-000; (77250)		EA	1										A8A4A16E4H1
X1-D		WASHER, LOCK: 1806-00; (78189)		EA	1										A8A4A16E4H2
X1-D		TERMINAL, LUG: 2104-06-02-2520N; (78189)		EA	REF										A8A4A16E5
X1-D		SCREW, MACHINE: P343-0327-000; (77250)		EA	1										A8A4A16E5H1
X1-D		WASHER, LOCK: 1806-00; (78189)		EA	1										A8A4A16E5H2
X1-D		TERMINAL, LUG: 2104-06-02-2520N; (78189)		EA	REF										A8A4A16E6

SECTION II

TM 11-5820-509-35

REPAIR PARTS FOR DIRECT SUPPORT, GENERAL SUPPORT, AND DEPOT MAINTENANCE (Continued)															
(1) SMR CODE	(2) FEDERAL STOCK NUMBER	(3) DESCRIPTION Reference Number & Mfr. Code Usable on Code		(4) UNIT OF MEAS	(5) QTY INC IN UNIT	(6) 30 DAY DS MAINTENANCE ALLOWANCE			(7) 30 DAY GS MAINTENANCE ALLOWANCE			(8) 1 YR ALW PER 100 EQUIP CNTGCTY	(9) DEPOT MAINT ALW PER 100 EQUIP	(10) ILLUSTRATION	
						(a)	(b)	(c)	(a)	(b)	(c)			(a) FIG NO.	(b) ITEM NO. OR REFERENCE DESIGNATION
						1-20	21-50	51-100	1-20	21-50	51-100				
X1-D		SCREW, MACHINE: P343-0327-000; (77250)		EA	1										A8A4A16E6H1
X1-D		WASHER, LOCK: 1806-00; (78189)		EA	1										A8A4A16E6H2
X1-D		TERMINAL, LUG: 2104-06-02-2520N; (78189)		EA	REF										A8A4A16E7
X1-D		SCREW, MACHINE: P343-0327-000; (77250)		EA	1										A8A4A16E7H1
X1-D		WASHER, LOCK: 1806-00; (78189)		EA	1										A8A4A16E7H2
X1-D		TERMINAL, LUG: 2104-06-02-2520N; (78189)		EA	REF										A8A4A16E8
X1-D		SCREW, MACHINE: P343-0327-000; (77250)		EA	1										A8A4A16E8H1
X1-D		WASHER, LOCK: 1806-00; (78189)		EA	1										A8A4A16E8H2
X1-D		TERMINAL, LUG: 2104-06-02-2520N; (78189)		EA	REF										A8A4A16E9
X1-D		SCREW, MACHINE: P343-0327-000; (77250)		EA	1										A8A4A16E9H1
X1-D		WASHER, LOCK: 1806-00; (78189)		EA	1										A8A4A16E9H2
P-D	5930-636-1425	SWITCH, THERMOSTATIC: C4344-4-75; (82647)		EA	1							*	*	3-65	A8A4K103
P-D	5305-054-5646	SCREW, MACHINE: MS51957-12; (96906)		EA	2							REF	REF		A8A4K103H1
P-D	5305-054-5646	SCREW, MACHINE: MS51957-12; (96906)		EA	REF							REF	REF		A8A4K103H2
P-D	5310-058-2949	WASHER, LOCK: 310-0278-000; (70318)		EA	2							REF	REF		A8A4K103H3
P-D	5310-058-2949	WASHER, LOCK: 310-0278-000; (70318)		EA	REF							REF	REF		A8A4K103H4
P-D	5930-820-9131	SWITCH, TOGGLE: T2150; (99707)		EA	1							*	*	3-65	A8A4S102
P-D	5975-836-3373	BOOT, DUST AND MOISTURE PROOF: N5030B; (97539)		EA	1							*	*		A8A4S102H1
P-D	5310-768-7967	WASHER: 500-1065-003; (13499)		EA	1							REF	REF		A8A4S102H2
P-D	5930-578-9817	SWITCH, TOGGLE: T3103; (81640)		EA	1							*	*		A8A4S2
P-D	5975-836-3373	BOOT, DUST AND MOISTURE PROOF: N5030B; (97539)		EA	1							REF	REF		A8A4S2H1
P-D	5310-768-7967	WASHER: 500-1065-003; (13499)		EA	1							REF	REF		A8A4S2H2
P-D		TERMINAL, LUG: 4007-4HT; (77147)		EA	1							REF	REF		A8A4E34
P-D	5940-878-3768	TERMINAL, LUG: 4007-6HT; (77147)		EA	2							*	*		A8A4E35
P-D		NUT, PLAIN, HEXAGON: P313-0140-000; (77250)		EA	1							*	*		A8A4E35H1

SECTION II

TM 11-5820-509-35

REPAIR PARTS FOR DIRECT SUPPORT, GENERAL SUPPORT, AND DEPOT MAINTENANCE (Continued)															
(1) SMR CODE	(2) FEDERAL STOCK NUMBER	(3) DESCRIPTION Reference Number & Mfr. Code Usable on Code		(4) UNIT OF MEAS	(5) QTY INC IN UNIT	(6) 30 DAY DS MAINTENANCE ALLOWANCE			(7) 30 DAY GS MAINTENANCE ALLOWANCE			(8) 1 YR ALW PER 100 EQUIP CNTGCTY	(9) DEPOT MAINT ALW PER 100 EQUIP	(10) ILLUSTRATION	
						(a)	(b)	(c)	(a)	(b)	(c)			(a) FIG NO.	(b) ITEM NO. OR REFERENCE DESIGNATION
						1-20	21-50	51-100	1-20	21-50	51-100				
P-D		SCREW, MACHINE: P343-0328-0; (77250)		EA	1							REF	REF		A8A4E35H2
P-D		WASHER, LOCK: 1806-00; (78189)		EA	1							REF	REF		A8A4E35H3
P-D		TERMINAL, LUG: 4007-6HT; (77147)		EA	REF							REF	REF		A8A4E36
P-D		TERMINAL, LUG: 2104-04-01-2520N; (78189)		EA	4							REF	REF		A8A4E37
P-D	5310-275-0889	NUT, PLAIN, HEXAGON: P313-0132-000; (77250)		EA	1							REF	REF		A8A4E37H1
P-D	5305-685-1490	SCREW, MACHINE: P330-2290-000; (77250)		EA	1							REF	REF		A8A4E37H2
P-D		WASHER, FLAT: 310-6325-000; (79807)		EA	1							REF	REF		A8A4E37H3
P-D	5310-058-2949	WASHER, LOCK: 310-0278-000; (70318)		EA	1							REF	REF		A8A4E37H4
P-D		TERMINAL, LUG: 2104-04-01-2520N; (78189)		EA	REF							REF	REF		A8A4E38
P-D	5310-275-0889	NUT, PLAIN, HEXAGON: P313-0132-000; (77250)		EA	1							REF	REF		A8A4E38H1
P-D	5305-685-1490	SCREW, MACHINE: P330-2290-000; (77250)		EA	1							REF	REF		A8A4E38H2
P-D		WASHER, FLAT: 310-6325-000; (79807)		EA	REF							REF	REF		A8A4E38H3
P-D	5310-058-2949	WASHER, LOCK: 310-0278-000; (70318)		EA	1							REF	REF		A8A4E38H4
P-D		TERMINAL, LUG: 2104-04-01-2520N; (78189)		EA	REF							REF	REF		A8A4E39
P-D	5310-275-0889	NUT, PLAIN, HEXAGON P313-0132-000; (77250)		EA	1							REF	REF		A8A4E39H1
P-D	5305-685-1490	SCREW, MACHINE P330-2290-000; (77250)		EA	1							REF	REF		A8A4E39H2
P-D		WASHER, FLAT 310-6325-000; (79807)		EA	1							REF	REF		A8A4E39H3
P-D	5310-058-2949	WASHER, LOCK 310-0278-000; (70318)		EA	1							REF	REF		A8A4E39H4
P-D		TERMINAL, LUG 2104-04-01-2520N; (78189)		EA	REF							REF	REF		A8A4E40
P-D	5940-156-7344	TERMINAL, LUG 2104-06-02-2520N, (78189)		EA	5							REF	REF		A8A4E41
P-D		SCREW, MACHINE P343-0328-000; (77250)		EA	1							REF	REF		A8A4E41H1
P-D		WASHER, LOCK: 806-00; (78189)		EA	1							REF	REF		A8A4E41H2
P-D	5940-156-7344	TERMINAL, LUG 2104-06-02-2520N; (78189)		EA	REF							REF	REF		A8A4E42
P-D		SCREW, MACHINE P343-0328-000, (77250)		EA	1							REF	REF		A8A4E42H1
P-D		WASHER, LOCK 1806-00; (78189)		EA	1							REF	REF		A8A4E42H2

SECTION II

TM 11-5820-509-35

REPAIR PARTS FOR DIRECT SUPPORT, GENERAL SUPPORT, AND DEPOT MAINTENANCE (Continued)															
(1) SMR CODE	(2) FEDERAL STOCK NUMBER	(3) DESCRIPTION Reference Number & Mfr. Code Usable on Code		(4) UNIT OF MEAS	(5) QTY INC IN UNIT	(6) 30 DAY DS MAINTENANCE ALLOWANCE			(7) 30 DAY GS MAINTENANCE ALLOWANCE			(8) 1 YR ALW PER 100 EQUIP CNTGCTY	(9) DEPOT MAINT ALW PER 100 EQUIP	(10) ILLUSTRATION	
						(a)	(b)	(c)	(a)	(b)	(c)			(a) FIG NO.	(b) ITEM NO. OR REFERENCE DESIGNATION
						1-20	21-50	51-100	1-20	21-50	51-100				
P-D	5940-156-7344	TERMINAL, LUG: 2104-06-02-2520N; (78189)		EA	REF							REF	REF		A8A4E43
P-D	5940-156-7344	TERMINAL, LUG: 2104-06-02-2520N; (78189)		EA	REF							REF	REF		A8A4E58
P-D	5940-156-7344	TERMINAL, LUG 2104-06-02-2520N; (78189)		EA	REF							REF	REF		A8A4E59
P-D	5940-836-3536	TERMINAL, LUG: 4040-2HDSPL; (77147)		EA	9							REF	REF		A8A4E44
P-D	5940-836-3536	TERMINAL, LUG 4040-2HDSPL (77147)		EA	REF							REF	REF		A8A4E45
P-D	5940-836-3536	TERMINAL, LUG: 4040-2HDSPL; (77147)		EA	REF							REF	REF		A8A4E46
P-D	5940-836-3536	TERMINAL, LUG: 4040-2HDSPL; (77147)		EA	REF							REF	REF		A8A4E47
P-D	5940-836-3536	TERMINAL, LUG: 4040-2HDSPL; (77147)		EA	REF							REF	REF		A8A4E48
P-D	5940-836-3536	TERMINAL, LUG: 4040-2HDSPL; (77147)		EA	REF							REF	REF		A8A4E49
P-D	5940-836-3536	TERMINAL, LUG: 4040-2HDSPL; (77147)		EA	REF							REF	REF		A8A4E50
P-D	5940-836-3536	TERMINAL, LUG: 4040-2HDSPL; (77147)		EA	REF							REF	REF		A8A4E51
P-D	5940-836-3536	TERm1AL, LUG: 4040-2HDSPL; (77 147)		EA	REF							REF	REF		A8A4E52
P-D	5940-455-7441	TERMINAL, LUG: 4040-5HDSPL, (77147)		EA	1							REF	REF		A8A4E53
P-D	5940-903-5951	TERMINAL, LUG 0167-3; (94375)		EA	1							*	*		A8A4E54
P-D	5940-501-8634	TERMINAL, LUG: 4021; (77147)		EA	1							*	*		A8A4E139
P-D		SCREW, MACHINE P343-0307-000; (77250)		EA	1							*	*		A8A4E139H1
P-D		WASHER, LOCK: 1808-00; (78189)		EA	1							*	*		A8A4E139H2
P-D	5940-700-2953	TERMINAL, LUG 549-6138-002; (13499)		EA	3							*	*		A8A4E55
P-D	5310-275-0889	NUT, PLAIN, HEXAGON P313-0132-000; (77250)		EA	1							REF	REF		A8A4E55H1
P-D	5305-685-1490	SCREW, MACHINE P330-2290-00; (77250)		EA	1							REF	REF		A8A4E55H2
P-D	5310-058-2949	WASHER, LOCK 310-278-000; (70318)		EA	1							REF	REF		A8A4E55H3
P-D		WASHER, PLAIN, FLAT: 310-6325-000; (79807)		EA	1							REF	REF		A8A4E55H4
P-D	5940-700-2953	TERMINAL, LUG 549-6138-002; (13499)		EA	REF							REF	REF		A8A4E56
P-D	5310-275-0889	NUT, PLAIN, HEXAGON: P313-0132-000; (77250)		EA	1							REF	REF		A8A4E56H1
P-D	5305-685-1490	SCREW, MACHINE P330-2290-000, (77250)		EA	1							REF	REF		A8A4E56H2

SECTION II

TM 11-5820-509-35

REPAIR PARTS FOR DIRECT SUPPORT, GENERAL SUPPORT, AND DEPOT MAINTENANCE (Continued)															
(1) SMR CODE	(2) FEDERAL STOCK NUMBER	(3) DESCRIPTION Reference Number & Mfr. Code Usable on Code		(4) UNIT OF MEAS	(5) QTY INC IN UNIT	(6) 30 DAY DS MAINTENANCE ALLOWANCE			(7) 30 DAY GS MAINTENANCE ALLOWANCE			(8) 1 YR ALW PER 100 EQUIP CNTGCV	(9) DEPOT MAINT ALW PER 100 EQUIP	(10) ILLUSTRATION	
						(a)	(b)	(c)	(a)	(b)	(c)			(a) FIG NO.	(b) ITEM NO. OR REFERENCE DESIGNATION
						1-20	21-50	51-100	1-20	21-50	51-100				
P-D		WASHER, LOCK: 310-0278-00; (70318)		EA	1							REF	REF		A8A4E56H3
P-D		WASHER, PLAIN, FLAT: 310-6325-000; (79807)		EA	1							REF	REF		A8A4E56H4
P-D	5940-700-2953	TERMINAL, LUG: 549-6138-002; (13499)		EA	REF							REF	REF		A8A4E57
P-D	5310-275-0889	NUT, PLAIN, HEXAGON: P313-0132-000; (T7250)		EA	1							REF	REF		A8A4E57H1
P-D	5305-685-1490	SCREW, MACHINE: P330-2290-00 0; (77250)		EA	1							REF	REF		A8A4E57H2
P-D		WASHER, FLAT: 310-6325-000; (79807)		EA	1							REF	REF		A8A4E57H3
P-D		WASHER, LOCK: 310-0278-000; (70318)		EA	1							REF	REF		A8A4E57H4
P-D	5940-259-8457	TERMINAL, STUD: RTMT12M; (91663)		EA	2							REF	REF		A8A4E7
P-D	5305-777-6039	SCREW, MACHINE: MS51959-12; (96906)		EA	1							REF	REF		A8A4E7H1
P-D	5900-259-8457	TERMINAL, STUD: RTM12M; (91663)		EA	REF							REF	REF		A8A4E8
P-D	5305-777-6039	SCREW, MACHINE: MS51959-12; (96906)		EA	1							REF	F-F		A8A4E8H1
P-D	5940-061-0050	TERMINAL, LUG: RTMT16M; (91663)		EA	8							*	*		A8A4E150
P-D	5305-054-5647	SCREW, MACHINE: MS51957-13 (96906)		EA	1							REF	REF		A8A4E150H1
P-D	5940-061-0050	TERMINAL, STUD: RTMT16M; (91663)		EA	REF							REF	REF		A8A4E151
P-D	5305-054-5647	SCREW, MACHINE: MS51957-13; (96906)		EA	1							REF	REF		A8A4E151H1
P-D	59h0-061-0050	TERMINAL, STUD: RTMT16M; (91663)		EA	REF							REF	REF		A8A4E152
P-D	5305-054-5617	SCREW, MACHINE: MS51957-13; (96906)		EA	1							REF	REF		A8A4E152H1
P-D	5940-061-0050	TERMINAL, STUD: RTMT16M; (91663)		EA	RF							REF	REF		A8A4E153
P-D	5305-054-5647	SCREW, MACHINE: MS51957-13; (96906)		EA	1							REF	REF		A8A4E153H1
P-D	5940-067-0050	TERMINAL, STUD: RTMT16M; (91663)		EA	REF							REF	REF		A8A4E154
P-D	5305-054-5647	SCREW, MACHINE: MS51957-13; (96906)		EA	1							REF	REF		A8A4E154H1
P-D	5940-061-0050	TERMINAL, STUD: RTMT16M; (91663)		EA	REF							REF	REF		A8A4E160
P-D	5305-054-5647	SCREW, MACHINE: MS51957-13; (96906)		EA	1							REF	REF		A8A4E160H1
P-D	5940-061-0050	TERMINAL, STUD: RTMT16M; (91663)		EA	REF							REF	REF		A8A4E167
P-D	5305-054-5647	SCREW, MACHINE: MS51957-13; (96906)		EA	1							REF	REF F		A8A4E167H1

SECTION II

TM 11-5820-509-35

REPAIR PARTS FOR DIRECT SUPPORT, GENERAL SUPPORT, AND DEPOT MAINTENANCE (Continued)															
(1) SMR CODE	(2) FEDERAL STOCK NUMBER	(3) DESCRIPTION Reference Number & Mfr. Code Usable on Code		(4) UNIT OF MEAS	(5) QTY INC IN UNIT	(6) 30 DAY DS MAINTENANCE ALLOWANCE			(7) 30 DAY GS MAINTENANCE ALLOWANCE			(8) 1 YR ALW PER 100 EQUIP CNTGCTY	(9) DEPOT MAINT ALW PER 100 EQUIP	(10) ILLUSTRATION	
						(a)	(b)	(c)	(a)	(b)	(c)			(a) FIG NO.	(b) ITEM NO. OR REFERENCE DESIGNATION
						1-20	21-50	51-100	1-20	21-50	51-100				
P-D		WASHER, LOCK: 310-0278-000; (70318)		EA	1							REF	REF		A8A4E167H2
P-D	5940-061-0050	TERMINAL, STUD: RTMT16M; (91663)		EA	REF							REF	REF		A8A4E168
P-D	5305-054-5647	SCREW, MACHINE: MS51957-13; (96906)		EA	1							REF	REF		A8A4E168H1
P-D		WASHER, LOCK: 310-0278-000; (70318)		EA	1							REF	REF		A8A4E168H2
P-D	5940-877-8430	TERMINAL, STUD: TF300; (98291)		EA	6							*	*		A8A4E1
P-D	5305-764-2966	SCREW, MACHINE: MS51959-2; (96906)		EA	1							REF	REF		A8A4E1H1
P-D		WASHER, SPRING, TENSION: 310-0075-000; (79807)		EA	1							REF	REF		A8A4E1H2
P-D	5940-877-8430	TERMINAL, STUD: TF300; (98291)		EA	REF							REF	REF		A8A4E2
P-D	5305-764-2966	SCREW, MACHINE: MS51959-2; (96906)		EA	1							REF	REF		A8A4E2H1
P-D	5940-877-8430	TERMINAL, STUD: TF300; (98291)		EA	REF							REF	REF		A8A4E3
P-D	5305-764-2966	SCREW, MACHINE: MS51959-2; (96906)		EA	1							REF	REF		A8A4E3H1
P-D	5940-877-8430	TERMINAL, STUD: TF300; (98291)		EA	REF							REF	REF		A8A4E4
P-D	5305-764-2966	SCREW, MACHINE: MS51959-2; (96906)		EA	1							REF	REF		A8A4E4H1
P-D	5940-877-8430	TERMINAL, STUD: TF300; (98291)		EA	REF							REF	REF		A8A4E5
P-D	5940-877-8430	TERMINAL, STUD: TF300; (98291)		EA	REF							REF	REF		A6A4E6
P-D	5950-951-1923	TRANSFORMER, POWER: 36665; (73386)		EA	1							*	*	3-67	A8A4T2
P-D	5310-614-3500	NUT, SELF-LOCKING, HEXAGON: 68-1660-40; (72962)		EA	2							REF	REF		A8A4T2H1
P-D	5310-614-3500	NUT, SELF-LOCKING, HEXAGON: 68-1660-40; (72962)		EA	REF							REF	REF		A8A4T2H2
P-D	5305-685-1490	SCREW, MACHINE: P330-2290-000; (77250)		EA	2							REF	REF		A8A4T2H3
P-D		SCREW, MACHINE: P330-2290-000; (77250)		EA	REF							REF	REF		A8A4T2H4
P-D	5950-987-8827	TRANSFORMER, POWER: 30697; (97965)		EA	1							*	*	3-67	A8A4T3
P-D	5310-614-3500	NUT, SELF-LOCKING, HEXAGON: 68-1660-40; (72962)		EA	2							REF	REF		A8A4T3H1
P-D	5310-614-3500	NUT, SELF-LOCKING, HEXAGON: 68-1660-40; (72962)		EA	REF							REF	REF		A8A4T3H2
P-D		SCREW, MACHINE: P330-2290-000; (77250)		EA	2							REF	REF		A8A4T3H3
P-D		SCREW, MACHINE: P330-2290-000; (77250)		EA	REF							REF	REF		A8A4T3H4

SECTION II

TM 11-5820-509-35

REPAIR PARTS FOR DIRECT SUPPORT, GENERAL SUPPORT, AND DEPOT MAINTENANCE (Continued)															
(1) SMR CODE	(2) FEDERAL STOCK NUMBER	(3) DESCRIPTION Reference Number & Mfr. Code Usable on Code		(4) UNIT OF MEAS	(5) QTY INC IN UNIT	(6) 30 DAY DS MAINTENANCE ALLOWANCE			(7) 30 DAY GS MAINTENANCE ALLOWANCE			(8) 1 YR ALW PER 100 EQUIP CNTGCTY	(9) DEPOT MAINT ALW PER 100 EQUIP	(10) ILLUSTRATION	
						(a)	(b)	(c)	(a)	(b)	(c)			(a) FIG NO.	(b) ITEM NO. OR REFERENCE DESIGNATION
						1-20	21-50	51-100	1-20	21-50	51-100				
P-D	5950-984-1111	TRANSFORMER, POWER: BC3072; (97315)		EA	1							*	*	3-67	A8A4T1
P-D		SCREW, MACHINE: P330-2290-000; (77250)		EA	2							REF	REF		A8A4T1H1
P-D		SCREW, MACHINE: P330-2290-000; (77250)		EA	REF							REF	REF		A8A 4T1H2
P-D	5961-945-5436	TRANSISTOR: 2N1166; (07688)		EA	2							*		3-67	A8A4Q1
P-D		NUT, PLAIN, HEXAGON: P313-0045-000; (77250)		EA	2							REF	REF		A8A4Q1H1
P-D		NUT, PLAIN, HEXAGON: P313-0045-000; (77250)		EA	REF							REF	REF		A8A4Q1H2
P-D		SCREW, MACHINE: P325-0064-000; (77250)		EA	2							*			A8A4Q1H3
P-D		SCREW, MACHINE: P325-0064-000; (77250)		EA	REF							REF	REF		A8A4Q1H4
P-D		WASHER, LOCK, SPLIT: 310-0071-000; (79807)		EA	2							REF	REF		A8A4Q1H5
P-D		WASHER, LOCK, SPLIT: 310-0071-000; (79807)		EA	REF							REF	REF		A8A4Q1H6
P-D		TRANSISTOR: 2N1166; (07688)		EA	REF							REF	REF	3-67	A8A4Q2
P-D		NUT, SELF-LOCKING, HEXAGON: P313-0045-000; (77250)		EA	2							REF	REF		A8A4Q2H1
P-D		NUT, SELF-LOCKING, HEXAGON: P313-0045-000; (77250)		EA	REF							REF	REF		A8A4Q2H2
P-D		SCREW, MACHINE: P325-0064-000; (77250)		EA	2							REF	REF		A8A4Q2H3
P-D		SCREW, MACHINE: P325-0064-000; (77250)		EA	REF							REF	REF		A8A4Q2H4
P-D		WASHER, LOCK, SPLIT: 310-0071-000; (79807)		EA	2							REF	REF		A8A4Q2H5
P-D		WASHER, LOCK, SPLIT: 310-0071-000; (79807)		EA	REF							REF	REF		A8A4Q2H6
P-D		TUBE, ELECTRON: 117WA; (06980)		EA	1							*	*	3-65	A8A4V101
P-D	5340-803-2373	WASHER: 542-1589-003; (13499)		EA	6							*	*		A8A4H7
P-D	5340-803-2373	WASHER: 542-1589-003; (13499)		EA	REF							REF	REF		A8A4H8
P-D	5340-803-2373	WASHER: 542-1589-003; (13499)		EA	REF							REF	REF		A8A4H9
P-D	5340-803-2373	WASHER: 542-1589-003; (13499)		EA	REF							REF	REF		A8A4H10
P-D	5340-803-2373	WASHER: 542-1589-003; (13499)		EA	REF							REF	REF		A8A4H11
P-D	5340-803-2373	WASHER: 542-1589-003; (13499)		EA	REF							REF	REF		A8A4H12
P-D	5310-158-5265	WASHER, FLAT: 302-0016-000; (13499)		EA	6							*	*		A8A4H13

SECTION II

TM 11-5820-509-35

REPAIR PARTS FOR DIRECT SUPPORT, GENERAL SUPPORT, AND DEPOT MAINTENANCE (Continued)															
(1) SMR CODE	(2) FEDERAL STOCK NUMBER	(3) DESCRIPTION Reference Number & Mfr. Code Usable on Code		(4) UNIT OF MEAS	(5) QTY INC IN UNIT	(6) 30 DAY DS MAINTENANCE ALLOWANCE			(7) 30 DAY GS MAINTENANCE ALLOWANCE			(8) 1 YR ALW PER 100 EQUIP CNTGCTY	(9) DEPOT MAINT ALW PER 100 EQUIP	(10) ILLUSTRATION	
						(a)	(b)	(c)	(a)	(b)	(c)			(a) FIG NO.	(b) ITEM NO. OR REFERENCE DESIGNATION
						1-20	21-50	51-100	1-20	21-50	51-100				
P-D		WASHER, FLAT: 302-0016-000; (13499)		EA	REF							REF	REF	A8A4H14	
P-D		WASHER, FLAT: 302-0016-000; (13499)		EA	REF							REF	REF	A8A4H15	
P-D		WASHER, FLAT: 302-0016-000; (13499)		EA	REF							REF	REF	A8A4H16	
P-D		WASHER, FLAT: 302-0016-000; (13499)		EA	REF							REF	REF	A8A4H17	
P-D		WASHER, FLAT: 302-0016-000; (13499)		EA	REF							REF	REF	A8A4H18	
M-D		BLOCK, STEPPED, MODULE- SECURING: 549-6654-002; (13499)		EA	1									A8MP1	
P-D	5305-054-5649	SCREW, MACHINE: MS51957-15; (96906)		EA	1							REF	REF	A8MP1H1	
P-D	5305-054-5651	SCREW, MACHINE: MS51957-17; (96906)		EA	1							*	*	A8MP1H2	
P-D	5310-782-1349	WASHER, FLAT: 310-005-000; (79807)		EA	2							REF	REF	A8MP1H3	
P-D	5310-782-1349	WASHER, FLAT: 310-0045-000; (79807)		EA	REF							REF	REF	A8MP1H4	
P-D	5310-933-8118	WASHER, LOCK, SPRING: MS35338-135; (96906)		EA	1							REF	REF	A8MP1H5	
M-D		CASE, RECEIVER, TRANSMITTER: 021-0194-000; (74284)		EA	1									A8MP2	
M-D		COVER, ASSEMBLY: 756-3009-002; (13499)		EA	1									A8MP3	
M-D		COVER, PANEL: 522-3354-004; (13499)		EA	1									A8A8	
P-D	5306-960-7330	STUD, WING: 548-7643-002; (13499)		EA	2							*	*	A8A8H2	
P-D	5305-981-5875	STUD, WING: 549-6398-002; (13499)		EA	4							*	*	A8A8H4	
P-D	5310-158-5256	WASHER: 553-5002-003; (13499)		EA	2							*	*	A8A8H2	
P-D	5310-158-5253	WASHER: 553-5004-003; (13499)		EA	4							*	*	A8A8H4	
P-D	5310-151-9030	WASHER, SEALING: 2110-0216CADPL; (25184)		EA	2							*	*	A8A8H2	
P-D	5330-618-9563	WASHER, SEALING: 110-6; (86579)		EA	4							REF	REF	A8A8H4	
M-D		COVER, PANEL: 021-0195-000; (714284)		EA	1									A8A8MP1	
P-D		CLAMP, FUSEHOLDER-CEMENTED: 548-7897-002; (13499)		EA	1							*	*	A8A8MP2	
P-D	5305-455-2512	SCREW, MACHINE: P342-1959-000; (77250)		EA	2							*	*	A8A8MP2H1	
P-D		SCREW, MACHINE: P342-1959-000; (77250)		EA	REF							REF	REF	A8A8MP2H2	
M-D		PLATE, IDENTIFICATION: 757-4768-000; (13499)		EA	1									A8A8MP3	

SECTION II

TM 11-5820-509-35

REPAIR PARTS FOR DIRECT SUPPORT, GENERAL SUPPORT, AND DEPOT MAINTENANCE (Continued)															
(1) SMR CODE	(2) FEDERAL STOCK NUMBER	(3) DESCRIPTION Reference Number & Mfr. Code Usable on Code		(4) UNIT OF MEAS	(5) QTY INC IN UNIT	(6) 30 DAY DS MAINTENANCE ALLOWANCE			(7) 30 DAY GS MAINTENANCE ALLOWANCE			(8) 1 YR ALW PER 100 EQUIP CNTGCTY	(9) DEPOT MAINT ALW PER 100 EQUIP	(10) ILLUSTRATION	
						(a)	(b)	(c)	(a)	(b)	(c)			(a) FIG NO.	(b) ITEM NO. OR REFERENCE DESIGNATION
						1-20	21-50	51-100	1-20	21-50	51-100				
M-D		PLATE, INSTRUCTION: M4496; (91345)		EA	1										A8A8MP4
M-D		PLATE, INSTRUCTION: 59-6658-004; (13L99)		EA	1										A8A8MP5
P-D		SCREW, TAPPING, THREAD-FORMING; 330-1194-000; (45722)		EA	8						*	*			A8A8MP5H1
P-D		SCREW, TAPPING, THREAD-FORMING; 330-1194-000; (L5722)		EA	REF						REF	REF			A8A8MP5H2
P-D		SCREW, TAPPING, THREAD FORMING; 330-1194-000; (45722)		EA	REP						REF	REF			A8A8MP5H3
P-D		SCREW, TAPPING, THREAD -FORMING; 330-1194-000; (45722)		EA	REF						REF	REF			A8A8MP5H4
P-D		SCREW, TAPPING, THREAD-FORMING; 330-1194-000; (45722)		EA	REF						REF	REF			A8A8MP5H5
P-D		SCREW, TAPPING, THREAD-FORMING; 330-1194-000; (45722)		EA	REF						REF	REF			A8A8MP5H6
P-D		SCREW, TAPPING, THREAD-FORMING; 330-1194-000; (45722)		EA	REF						REF	REF			A8A8MP5H7
P-D		SCREW, TAPPING, THREAD-FORMING; 330-1194-000; (45722)		EA	REF						REP	REF			A8A8MP5H8
P-D		WASHER, LOCK: 310-0280-000; (70318)		EA	8						*	*			A8A8MP5H9
P-D		WASHER, LOCK: 310-0280-000; (70318)		EA	REF						REF	REF			A8A8MP5H10
P-D		WASHER, LOCK: 310-0280-000; (70318)		EA	REF						REF	REF			A8A8MP5H11
P-D		WASHER, LOCK: 310-0280-000; (70318)		EA	REF						REF	REF			A8A8MP5H12
P-D		WASHER, LOCK: 310-0280-000; (70318)		EA	REF						REF	REF			A8A8MP5H13
P-D		WASHER, LOCK: 310-0280-000; (70318)		EA	REF						REF	REF			A8A8MP5H14
P-D		WASHER, LOCK: 310-0280-000; (70318)		EA	REF						REF	REF			A8A8MP5H15
P-D		WASHER, LOCK: 310-0280-000; (70318)		EA	REF						REF	REF			A8A8MP5H16
M-D		GASKET, PANEL: 548-9308-003; (13499)		EA	1										A8A9
P-D	5330-892-4773	RUBBER, ROUND SECTION: R1412NSC41 7-32INDIA; (08076)		EA	5						*	*			A8A9MP1
M-D		PLATE, ELECTRICAL SHIELD: 756-0482-000; (13499)		EA	1										A8MP4
M-D		PLATE, IDENTIFICATION: 757-4767-000; (13499)		EA	1										A8MP5
P-D	5305-494-7333	SCREW, MACHINE: P343-0019-000; (77250)		EA	2						*	*			A8MP5H1
P-D		SCREW, MACHINE: P343-0019-000; (77250)		EA	REF						REF	REF			A8MP5H2
P-D		WASHER, LOCK: MS35338-135; (96906)		EA	2						REF	REF			A8MP5H3

SECTION III

TM 11-5820-509-35

SPECIAL TOOLS, TEST & SUPPORT EQUIPMENT FOR DIRECT SUPPORT, GENERAL SUPPORT, AND DEPOT MAINTENANCE															
(1) SMR CODE	(2) FEDERAL STOCK NUMBER	(3) DESCRIPTION Reference Number & Mfr. Code Usable on Code		(4) UNIT OF MEAS	(5) QTY INC IN UNIT	(6) 30 DAY DS MAINTENANCE ALLOWANCE			(7) 30 DAY GS MAINTENANCE ALLOWANCE			(8) 1 YR ALW PER 100 EQUIP CNTGCTY	(9) DEPOT MAINT ALW PER 100 EQUIP	(10) ILLUSTRATION	
						(a) 1-20	(b) 21-50	(c) 51-100	(a) 1-20	(b) 21-50	(c) 51-100			(a) FIG NO.	(b) ITEM NO. OR REFERENCE DESIGNATION
P-D		WASHER, LOCK: MS35338-135; (96906)		EA	REF							REF	REP		A8MP5H4
P-D		PLATE, IDENTIFICATION: 757-4768-080; (13499)		EA	1										A8MP6
P-D	5310-275-0889	NUT, PLAIN: P313-0132-000; (77250)		EA	2							REF	REF		A8MP6H1
P-D	5310-275-0889	NUT, PLAIN, HEXAGON: P313-0132-000; (77250)		EA	REF							REF	REF		A8MP6H2
P-D	5305-145-0887	SCREW, MACHINE: P342-1958-000; (77250)		EA	2							*	*		A8MP6H3
P-D		SCREW, MACHINE: P342-1958-000; (77250)		EA	REF							REF	REF		A8MP6H4
P-D		PLATE, IDENTIFICATION: 747-4769-000; (13499)		EA	1										A8MP7
P-D		STRAP, SECURING, RIVETED: 549-6656-003; (13499)		EA	1										A8MP8
P-D	5305-054-5648	SCREW, MACHINE: M51957-14; (96906)		EA	1							REF	REF		A8MP8H1
P-D	5305-054-6651	SCREW, MACHINE: M51957-27; (96906)		EA	1							REF	REF		A8MP8H2
P-D	5310-782-1349	WASHER, FLAT: 310-0045-000; (79807)		EA	1							REF	REF		A8MP8H3
P-D	5310-531-9514	WASHER, FLAT: 310-6360-000; (79807)		EA	1							REF	REF		A8MP8H4
M-D		RUCKSACK: 021-0191-00; (24036)		EA	1										MP5

SECTION II

TM 11-5820-509-35

REPAIR PARTS FOR DIRECT SUPPORT, GENERAL SUPPORT, AND DEPOT MAINTENANCE (Continued)																
(1) SMR CODE	(2) FEDERAL STOCK NUMBER	(3) DESCRIPTION Reference Number & Mfr. Code Usable on Code		(4) UNIT OF MEAS	(5) QTY INC IN UNIT	(6) 30 DAY DS MAINTENANCE ALLOWANCE			(7) 30 DAY GS MAINTENANCE ALLOWANCE			(8) 1 YR ALW PER 100 EQUIP CNTGCTY	(9) DEPOT MAINT ALW PER 100 EQUIP	(10) ILLUSTRATION		
						(a) 1-20	(b) 21-50	(c) 51-100	(a) 1-20	(b) 21-50	(c) 51-100			(a) FIG NO.	(b) ITEM NO. OR REFERENCE DESIGNATION	
P-H	5995-087-2324	CABLE ASSEMBLY, POWER, ELECTRICAL CX8393PRC47; (80058)		EA	1				*	*	*	*	*	*		W1
P-H	5995-082-0487	CABLE ASSEMBLY, POWER, ELECTRICAL CX8394PRC47; (80058)		EA	1				*	*	*	*	*	*		W2
P-H	5995-087-2325	CABLE ASSEMBLY, POWER, ELECTRICAL CX8395PRC47; (80058)		EA	1				*	*	*	*	*	*		W3
P-H		CORD ASSEMBLY, ELECTRICAL 10747J, (82872)		EA	1				*	*	*	*	*	*		W4

SECTION IV INDEX-FEDERAL STOCK NUMBER AND REFERENCE NUMBER CROSS REFERENCE TO FIGURE AND ITEM NUMBER OR REFERENCE DESIGNATION (CONTINUED)

FEDERAL STOCK NUMBER	FIGURE NUMBER	ITEM NUMBER OR REF. DESIGNATION	FEDERAL STOCK NUMBER	FIGURE NUMBER	ITEM NUMBER OR REF. DESIGNATION
3010-984-1099		A8A7A1	3120-865-8571		A8A4A6MP13
3020-088-1785		ASA4A6M42	3120-865-8571		AA4A6MP14
3020-088-4507		A8SAA6P64	3120-865-8571		A8A4A6L1P15
3020-088-6021		A8A4P36	3120-865-8571		A8A4A6UP16
3020-951-0700		A8A4P35	3120-865-8571		A8A4A6W17
3020-976-5392		A8A4A6A3	3120-865-8571		AA7YP3
3020-976-5393		A8AS5	5110-115-5049		A6A4
3020-985-2235		A8AA6A6	5305-053-1523		A8A7A1A31H2
3020-985-2236		A8A4AQ62	5305-054-5636		ASA3E13H1
3020-985-3351		ASA3NP27	5305-054-5636		A8A3E13H2
3020-985-3351		A8SA328	5305-054-5636		A8A3E15H1
3020-988-0687		A8A46YMP41	5305-054-5636		A8A3E15H2
3020-988-6910		A8A4A6MP43	5305-054-5636		A8A3E4612
3040-950-9578		A8A4A6P22	5305-054-5636		A8A7MP13H1
3040-950-9578		A8A4A6MP23	5305-054-5636		A8A7MP13J12
3040-950-9578		A8A4A6P24	5305-054-5636		A8A7MP13I3
3040-950-9578		A8A46MP25	5305-054-5636		A8A7YP14H1
3040-950-9578		6A8A46P26	5305-054-5636		A8A7MP14H2
3040-950-9578		A8A46UP27	5305-054-5636		A8A711P14H3
3040-977-1551		AMAE6MP37	5305-054-5637		A8A5P112
3110-851-7674		A8A3YP3	5305-054-5637		A8A5P1113
3110-851-7674		8A3NP4	5305-054-5646		APA3E11111
3120-709-5460		8A4UP1	5305-054-5646		A8A3E46H1
3120-709-5460		A8A4P2	5305-054-5646		A8A4K103H1
3120-709-5460		A84P3	5305-054-5646		A8A4K103H2
3120-709-5460		A8AP4	5305-054-5646		A8A5E18H1
3120-709-5460		A8A4P5	5305-054-5646		A8A5hn11
3120-709-5460		8A4Y6	5305-054-5647		AeA3A2H2
3120-793-6354		A8A4P7	5305-054-5647		A8A3A3H2
3120-793-6354		A8AP8	5305-054-5647		A8A3A9A3114
3120-865-8571		A8A4AIP11	5305-054-5647		A8A3EIOHI
3120-865-8571		A84AW6EP12	5305-054-5647		A8A3EXOH2

SECTION IV INDEX-FEDERAL STOCK NUMBER AND REFERENCE NUMBER CROSS REFERENCE TO FIGURE AND ITEM NUMBER OR REFERENCE DESIGNATION (CONTINUED)

FEDERAL STOCK NUMBER	FIGURE NUMBER	ITEM NUMBER OR REF. DESIGNATION	FEDERAL STOCK NUMBER	FIGURE NUMBER	ITEM NUMBER OR REF. DESIGNATION
5305-054-5647		A8A3MP24H10	5305-054-5647		A8A4MP25H11
5305-054-5647		A8A3MP24H11	5305-054-5647		A8A4MP25H2
5305-054-5647		A8A3MP24H12	5305-054-5647		A8A4MP25H3
5305-054-5647		A8A3AP24H13	5305-054-5647		A8A4/P25H4
5305-054-5647		A8A3MP24H14	5305-054-5647		A8A4MP25H5
5305-054-5647		A8A3MP24H15	5305-054-5647		A8A4MP25H6
5305-054-5647		A8A3MP24H16	5305-054-5647		A8A4MP25H7
5305-054-5647		A8A3MP24H17	5305-054-5647		A8A4MP25H8
5305-054-5647		A8A31P24H18	5305-054-5647		A8A4MP25H9
5305-054-5647		A8A3UP24H19	5305-054-5647		A8A4P26H1
5305-054-5647		A8A3MP24H20	5305-054-5647		A8AIP26H10
5305-054-5647		A8A31P24H5	5305-054-5647		A8A49P26H11
5305-054-5647		A8A3MP24H6	5305-054-5647		A8A4UP26H2
5305-054-5647		A8A3MP24H7	5305-054-5647		A8A4MP26H3
5305-054-5647		A8A3MP24H8	5305-054-5647		A8A4MP26H4
5305-054-5647		A8A3MP24H9	5305-054-5647		A8A4MP26H5
5305-054-5647		A8A3P238H1	5305-054-5647		A8A4MP26H6
5305-054-5647		A8A3MP38H2	5305-054-5647		A8A4MP26H7
5305-054-5647		A8A3MP38H3	5305-054-5647		A8AMP26H8
5305-054-5647		A8A3MP38H4	5305-054-5647		A8A4MP26H9
5305-054-5647		A8A4E150H1	5305-054-5647		A8A5E1H4
5305-054-5647		A8A4E151H1	5305-054-5647		A8A5E17H2
5305-054-5647		A8A4E152H1	5305-054-5647		A8A7AIA3H1
5305-054-5647		A8A4E153H1	5305-054-5647		A8A7MP8H1
5305-054-5647		A8A4E154H1	5305-054-5647		A8A7MP8H10
5305-054-5647		A8A4E160H1	5305-054-5647		A8A7MP8H11
5305-054-5647		A8A4E167H1	5305-054-5647		A8A7MP8H2
5305-054-5647		A8A4E168H1	5305-054-5647		A8A7MP8H3
5305-054-5647		A8A4K1O2H3	5305-054-5647		A8AMP8H4
5305-054-5647		A8A4K1O2H4	5305-054-5647		A8A7MP8H5
5305-054-5647		A8A41T25H1	5305-054-5647		A8A7MP8H6
5305-054-5647		A8A4MP25H10	5305-054-5647		A8A7MP8H7

SECTION IV INDEX-FEDERAL STOCK NUMBER AND REFERENCE NUMBER CROSS REFERENCE TO FIGURE AND ITEM NUMBER OR REFERENCE DESIGNATION (CONTINUED)

FEDERAL STOCK NUMBER	FIGURE NUMBER	ITEM NUMBER OR REF. DESIGNATION	FEDERAL STOCK NUMBER	FIGURE NUMBER	ITEM NUMBER OR REF. DESIGNATION
5305-054-5647		A8A7P8H8	5305-059-8248		A8A4C123H2
5305-054-5647		A8A7MP8H9	5305-071-1325		A7AIP10H3
5305-054-5651		A8MP1H2	5305-071-1325		A7A1P101H4
5305-054-5653		A8A3A9A1H	5305-071-1325		A7A 1MP11H3
5305-054-5653		A8A7E7A1H2	5305-071-1325		A7AIMP11H4
5305-054-6650		A8AMP36H3	5305-071-1325		A7A21P10H3
5305-054-6650		A8A4MP36H4	5305-071-1325		A7A2NP1014
5305-054-6650		A8455H1	5305-071-1325		A7AZUMP11H3
5305-054-6650		A8A4P5H2	5305-071-1325		A7A2UP11H4
5305-054-6650		A8AP55H3	5305-141-4310		A8A3MP13H1
5305-054-6650		A8A4P55H4	5305-141-4310		A8AWU14HI
5305-054-6650		A8A4MP55H5	5305-151-0732		48A6P1H2
5305-054-6650		A8A455H6	5305-151-07 32		A8A6P1H3
5305-054-6651		A84A1H2	5305-151-1320		A8A4A16H1
5305-054-6651		A8A46U21H11	5305-206-1270	3-21	A8AP3H1
5305-054-6651		A8A4A1P212	5305-206-1270		A8A3E30H2
5305-054-6651		A8A5A1H2	5305-206-1270		A8A3E31H2
5305-054-6651		A8A1P2H1	5305-206-1270		A8A3E32H2
5305-054-6651		A8AUP2H2	5305-206-1270		A8A3E33H2
5305-054-6651		A8AP8H2	5305-206-1270		A8A3E34H2
5305-054-6652		A8A4A1H2	5305-206-1270		A8A3E35H2
5305-054-6652		8AA6A152H	5305-206-1270		A8A3E36H2
5305-054-6652		ASA5P91	5305-206-1270		AA7MP7H1
5305-054-6653		A8SWP2H2	5305-206-1270		A8A7P7H2
5305-054-6653		A8A5T1H3	5305-206-3716		A8A6E3H1
5305-054-6653		ASA5T14	5305-297-4351		A8A4A6E1H1
5305-054-6660		ABA5T2H2	5305-407-8559		A8A7E7A2E1H3
5305-054-6668		A8A5P4H1	5305-407-8559		A8A7E7A2E1H4
5305-054-6668		88AA6H6	5305-407-8559		A8A7E7A2E1H4
5305-059-3663		A6IP5H1	5305-531-0137		A8WAP24H1
5305-059-3663		A6P6H1	5305-531-0137		A8A4MP24H2

SECTION IV INDEX-FEDERAL STOCK NUMBER AND REFERENCE NUMBER CROSS REFERENCE TO FIGURE AND ITEM NUMBER OR REFERENCE DESIGNATION (CONTINUED)

FEDERAL STOCK NUMBER	FIGURE NUMBER	ITEM NUMBER OR REF. DESIGNATION	FEDERAL STOCK NUMBER	FIGURE NUMBER	ITEM NUMBER OR REF. DESIGNATION
5305-531-0137		A8A4MP42H1	5305-763-7822		ABA7P2H2
5305-531-0137		A8A4P42H2	5305-764-0068		AAUP27H1
5305-531-0137		A8A4MP45H1	5305-764-0068		A8A4MP2H2
5305-531-p137		A8AMP45H2	5305-764-0068		A8A427H3
5305-531-0137		A8A4AP46H1	5305-764-0068		A8A4MP27H4
5305-531-0137		A8A4MP46H2	5305-764-2964		A8A2P4H3
5305-616-1815		A8A3E37H2	5305-764-2964		A8A2P4H4
5305-637-4225		A8A4MP22H2	5305-764-2964		A8A5UP3H2
5305-637-4225		A8A4MP23H2	5305-764-2964		A8A5MP3H3
5305-680-9157		A8A3E38H3	5305-764-2966		A8A3MP26H1
5305-705-9528		A8A1Q11H2	5305-764-2966		A8A3M26H2
5305-716-7733		A8A4A6MP22H1	5305-764-2966		A8A3MP26H3
5305-719-5064		A5E2H	5305-764-2966		A8A4A6A6NP1H1
5305-719-5064		A5E2H2	5305-764-2966		A8A4A6A6MP1H2
5305-719-5064		A5E2H3	5305-764-2966		A8A4A6A6MP1H3
5305-719-5064		A8A4A6H2	5305-764-2966		A8A4A6A6MP1H4
5305-724-3842		A8A4MP54H1	5305-764-2966		A8A4E1H1
5305-724-3842		A8A4MP54H2	5305-764-2966		A8A4E2H1
5305-724-3842		A8A4MP54H3	5305-764-2966		ASA4E3H1
5305-724-3842		A8A4MP54H4	5305-764-2966		A8AE4H
5305-763-6963		A8AK2H3	5305-762422		A4A6A5UP1H
5305-763-6963		A8A4K2H4	5305-766-2422		A8A4A6A5WP1H2
5305-763-6963		A8A5T1H1	5305-766-2422		AA4A6A51PH3
5305-763-6963		A8A5T1H2	5305-766-2422		AAA6A5U1H4
5305-763-7822		A6A3A11	5305-770-2533		A8A1T2H1
5305-763-7822		A6A3A2H1	5305-770-2533		A8A1T2H2
5305-763-7822		A8A3P1H4	5305-770-2533		A8A1PH3
5305-763-7822		A8A4MP14H	5305-770-2533		A8A1PH4
5305-763-7822		A8A4FL2H2	5305-770-2533		A8A1T2H3
5305-763-7822		A8A5E3H2	5305-770-2533		A8A1T2H4
5305-763-7822		AA7P1H3	5305-770-2533		A8A1T3H1
5305-763-7822		A8A7P1H4	5305-770-2533		A8A1T3H2

SECTION IV INDEX-FEDERAL STOCK NUMBER AND REFERENCE NUMBER CROSS REFERENCE TO FIGURE AND ITEM NUMBER OR REFERENCE DESIGNATION (CONTINUED)

FEDERAL STOCK NUMBER	FIGURE NUMBER	ITEM NUMBER OR REF. DESIGNATION	FEDERAL STOCK NUMBER	FIGURE NUMBER	ITEM NUMBER OR REF. DESIGNATION
5305-770-2533		A8A1T3H3	5305-938-4044		A8A4A166H1
5305-770-2533		AA1T3H4	5305-942-8431		A8A46MP46H1
5305-770-2533		A8AIT5H1	5305-942-8431		A8A4A6MP46H2
5305-770-2533		A8A1T5H2	5305-981-5875		A8A8H4
5305-770-2533		A8A1T5H3	5305-984-2144		A8A4A6MP56
5305-770-2533		A8A1T5H4	5305-984-2144		A8A4A6MP58
5305-770-2533		ASA3L98H1	5305-984-2144		A8A4A6MP60
5305-770-2533		A8A3P1H3	5306-960-7330		A8A8H2
5305-770-2533		A8A3P2H3	5310-058-3599		A8A45TB1H1
5305-770-2533		A8A3P2H4	5310-058-3599		A8A5XC20H4
5305-770-2533		A8A3P3H3	5310-058-3599		A8A7P2H3
5305-770-2533		A8A3P3H4	5310-167-0797		A8A2P3H5
5305-770-2533		A8A3P4H3	5310-167-0797		A8A2P3H6
5305-770-2533		A8A3P4H4	5310-167-0797		A8A2P4H5
5305-770-2533		A8A7NP12H1	5310-167-0797		A8A2P4H6
5305-770-2533		A8A7MP12H2	5310-167-0837		A8A4A7H2
5305-770-2533		A8A7MP12H3	5310-178-8631		A8A4C146H2
5305-770-2533		A8A7NP12H4	5310-184-8990		A8A7TB1E2H2
5305-770-2533		A8A7P21H	5310-184-8996		A8A7MP7H3
5305-770-2579		ASA4MP15H1	5310-184-8996		A8A7MP7H4
5305-770-2579		A8A4MP16H1	5310-187-0159		A8A4C29H2
5305-770-2579		A8A4MP17H1	5310-187-0159		A8A4C30H2
5305-770-2580		A6MP7H1	5310-208-6841		A8A4C146H1
5305-770-2580		A6MP7H2	5310-209-0960		A8A4A3A3H2
5305-788-9882		A8A4H5	5310-275-5147		AA3MP7H1
5305-805-9801		A8A3MP15H1	5310-275-5147		A8A3MP8H1
5305-805-9801		A8A3MP15H2	5310-276-1104		A8A3P12H1
5305-805-9801		A8A3MP1H3	5310-276-1104		A8A4MP22H1
5305-805-9801		ASA3MP15H4	5310-276-110 4		A8A4MP23H1
5305-922-6281		A8A4MP61H1	5310-530-3549		A8SA7A1H4
5305-938-4044		A8A3TB1H2	5310-551-9284		A8A4A6MP1H13
5305-938-4044		A8A3TB2H2	5310-551-9284		A8A4A6P1H14

SECTION IV INDEX-FEDERAL STOCK NUMBER AND REFERENCE NUMBER CROSS REFERENCE TO FIGURE AND ITEM NUMBER OR REFERENCE DESIGNATION (CONTINUED)

FEDERAL STOCK NUMBER	FIGURE NUMBER	ITEM NUMBER OR REF. DESIGNATION	FEDERAL STOCK NUMBER	FIGURE NUMBER	ITEM NUMBER OR REF. DESIGNATION
5310-551-9284		A8A4A6MP1H15	5310-614-3500		A8A7P1H2
5310-551-9284		A8A4A6MP1H16	5310-616-8660		A8A5T2H1
5310-551-9284		A8A4A6MP1H17	5310-685-7739		A8A3P1H1
5310-551-9284		A8A4A6MP1H18	5310-685-7739		A8A3P2H1
5310-551-9286		A8A5R22H4	5310-685-7739		A8A3P3H1
5310-551-9286		A8A5R3H4	5310-685-7739		A8A3P4H1
5310-551-9286		A8A5R4H4	5310-925-7991		A8A4E29H3
5310-558-4187		A8A4MP13H2	5310-925-7991		A8A4E29H4
5310-559-0575		A8A4C29H1	5310-925-7991		A8A4E30H3
5310-559-0575		A8A4C30H1	5310-925-7991		A8A4E30H4
5310-591-3416		A8A4A16H2	5310-925-7991		A8A4E31H3
5310-614-3500		A8A3A2H2	5310-925-7991		A8A4E31H4
5310-614-3500		A8A4K1H1	5310-925-7991		A8A4E32H3
5310-614-3500		A8A4K1H2	5310-925-7991		A8A4E32H4
5310-614-3500		A8A4K3H1	5310-928-2690		A8A3E13H3
5310-614-3500		A8A4K3H2	5310-928-2690		A8A3E13H4
5310-614-3500		A8A4K4H1	5310-928-2690		A8A3E15H3
5310-614-3500		A8A4K4H2	5310-928-2690		A8A3E15H4
5310-614-3500		A8A4K6H1	5310-928-2690		A8A4J5H6
5310-614-3500		A8A4K6H2	5310-928-2690		A8A4J7H6
5310-614-3500		A8A4R8H1	5310-928-26 90		A8A5E5H3
5310-614-3500		A8A4R8H2	5310-928-2690		A8A7MP13H4
5310-614-3500		A8A4T2H1	5310-928-2690		A8A7MP13H5
5310-614-3500		A8A4T2H2	5310-928-2690		A8A7MP13H6
5310-614-3500		A8A4T3H1	5310-928-2690		A8A7MP14H4
5310-614-3500		A8A4T3H2	5310-928-2690		A8A7MP14H5
5310-614-3500		A8A5E3H2	5310-928-2690		A8A7MAP14H6
5310-614-3500		A8A5XC19H1	5310-929-6395		A8A5T2F5
5310-614-3500		A8A5XC19H2	5310-933-8119		A8A4A6H6
9310-614-3500		A8A5XC20H1	5310-933-8119		A8A4A6UP46H3
5310-614-3500		A8A7E7A1H2	5310-933-8119		A8A4A6MP46H4
5310-614-3500		A8A7P1H1	5310-933-8119		48A4A6MP47H3

SECTION IV INDEX-FEDERAL STOCK NUMBER AND REFERENCE NUMBER CROSS REFERENCE TO FIGURE AND ITEM NUMBER OR REFERENCE DESIGNATION (CONTINUED)

FEDERAL STOCK NUMBER	FIGURE NUMBER	ITEM NUMBER OR REF. DESIGNATION	FEDERAL STOCK NUMBER	FIGURE NUMBER	ITEM NUMBER OR REF. DESIGNATION
5310-933-8119		A8A4A6MP47H4	5310-934-9765		A7A1MP10H1
5310-933-8119		A8A4MP61H2	5310-934-9765		A7A1MP10H2
5310-933-8119		A8A4MP62H2	5310-934-9765		A7A1MP11H1
5310-933-8119		A8A4MP63H2	5310-934-9765		A7A1MP11H2
5310-933-8119		A8A4MP64H2	5310-934-9765		A7A2MP10H1
5310-933-8119		A8A4MP65H2	5310-934-9765		A7A2MP10H2
5310-933-8119		A8A4MP66H2	5310-934-9765		A7A2MP11H1
5310-933-8119		A8A4UP67H2	5310-934-9765		A7A2MP11H2
5310-933-8119		A8A4MP68H2	5310-938-2013		A8A5E5H1
5310-933-8119		A8A4MP69H2	5310-938-8387		A7A1H1
5310-933-8119		A8A4MP70H2	5310-938-8387		A7A1H2
5310-933-8119		A8A4MP70H2	5310-938-8387		A7A2H1
5310-933-8119		A8A4MP72H2	5310-938-8387		A7A2H2
5310-933-8119		A8A47MP3H2	5310-939-0903		A8A4C123H3
5310-933-8119		A8A4MP74H2	5310-948-8598		A8A4A6NP54
5310-933-8119		A8A4MP75H2	5310-952-1423		A8A3H3
5310-933-8119		A8A4MP76H2	5310-952-1423		A8A3H4
5310-933-8119		A8A4MP77H2	5310-952-1423		A8A3H5
5310-933-8119		A8A4MP78H2	5310-952-1423		A8A3H6
5310-933-8119		A8A4MP79H2	5310-952-1423		A8A3H7
5310-933-8119		A8A4MP80H2	5310-952-1423		A8A3H8
5310-933-8119		A8A4MP81H2	5315-058-9698		A8A7A2MP1
5310-933-8119		A8A5MP4H2	5315-058-9698		A8A7A3MP1
5310-933-8119		A8A5MP8H4	5315-531-9482		A8A3A7MP1
5310-933-8120		A7A1MP10H5	5315-531-9482		A8A3A7MP2
5310-933-8120		A7A1MP10H6	5315-614-3586		A8A3A6NP4
5310-933-8120		A7A1MP11H5	5315-614-3586		A8A3A6MP5
5310-933-8120		A7A1MP11H6	5315-823-8744		A5A1MP1
5310-933-8120		A7A2MP10H5	5315-823-8746		A5MP5
5310-933-8120		A7A2MP10H6	5315-853-0681		A8A3ASMP1
5310-933-8120		A7A2MP11H5	5315-881-2253		A8A4A6A8MP1
5310-933-8120		A7A2MP11H6	5315-881-2253		A8A4A6A8P2

SECTION IV INDEX-FEDERAL STOCK NUMBER AND REFERENCE NUMBER CROSS REFERENCE TO FIGURE AND ITEM NUMBER OR REFERENCE DESIGNATION (CONTINUED)

FEDERAL STOCK NUMBER	FIGURE NUMBER	ITEM NUMBER OR REF. DESIGNATION	FEDERAL STOCK NUMBER	FIGURE NUMBER	ITEM NUMBER OR REF. DESIGNATION
5315-987-8790		A8A3A7MP6	5330-981-7538		A8A4MP33
5325-248-7031		A8A4H6	5340-124-3383		A8A4A6H15
5325-276-4993		A8A3H2	5340-124-3383		A8A4A6H16
5325-276-4993		A8A4H4	5340-124-3383		A8A4A6H17
5325-276-4993		A8A4H5	5340-205-6694		A8A4H3
5325-286-6047		A8A2H1	5340-205-6694		A8A4H4
5325-286-6047		A8A4H2	5340-205-6694		A8A4H5
5325-286-6047		A8A4H3	5340-205-6694		A8A4H6
5325-960-2410		A8A3MP10	5340-282-1633		A8A3H10
5325-960-2410		A8A3MP11	5340-282-1633		A8A3H11
5325-960-2410		A8A3MP12	5340-282-1633		A8A3H12
5325-960-2410		A8A3MP13	5340-282-1633		A8A3H9
5325-960-2410		A8A5MP6	5340-290-0939		A8A4MP1
5330-558-2310		A8AH5	5340-290-0939		A8A4MP2
5330-559-8909		A8A4A6MP1H19	5340-479-9197		A8A3A5MP1
5330-559-8909		A8A4A6MP1H20	5340-479-9197		A8A3A5MP2
5330-559-8909		A8A4A6MP1H21	5340-479-9197		A8A3A6MP1
5330-559-8909		A8A4A6MP1H22	5340-479-9197		A8A3A6MP2
5330-559-8909		A8A4A6MP1H23	5340-598-1300		A8A4H1
5330-559-8909		A8A4A6MP1H24	5340-598-1300		A8A4H2
5330-559-8909		A8A4A6MP46H5	5340-602-6075		A8A4A6H1
5330-559-8909		A8A4A6MP46H6	5340-602-6075		A8A4A6H2
5330-559-8909		A8A4A6MP47H5	5340-602-6075		A8A4A6H3
5330-559-8909		A8A4A6MP47H6	5340-663-1245		A8A7H1
5330-618-3447		A8A4A6MP32	5340-663-1245		ASA7H2
5330-618-3447		A8A4A6MP33	5340-695-2558		A8A4MP61
5330-618-3447		A8A4A6MP34	5340-695-2558		A8A4MP62
5330-618-9563		A8A4A6E3H3	5340-695-2558		A8A4MP63
5330-618-9563		A8A4A6E4H3	5340-695-2558		A8A4MP64
5330-618-9563		A8A8H4	5340-695-2558		A8A4MP65
5330-892-4773		A8A9MP1	5340-695-2558		A8A4MP66
5330-981-7538		A8A4MP32	5340-695-2558		A8A4MP67

SECTION IV INDEX-FEDERAL STOCK NUMBER AND REFERENCE NUMBER CROSS REFERENCE TO FIGURE AND ITEM NUMBER OR REFERENCE DESIGNATION (CONTINUED)

FEDERAL STOCK NUMBER	FIGURE NUMBER	ITEM NUMBER OR REF. DESIGNATION	FEDERAL STOCK NUMBER	FIGURE NUMBER	ITEM NUMBER OR REF. DESIGNATION
5340-695-2558		A8A4MP68	5340-975-7637		A8A3E16
5340-695-2558		A8A4MP69	5340-975-7637		A8A5E4
5340-695-2558		A8A4MP70	5340-975-7637		A8A7E8
5340-695-2558		A8A4MP71	5340-984-0423		A8A5MP7
5340-695-2558		A8A4MP72	5340-984-0423		A8A5MP8
5340-695-2558		A8A4MP73	5340-984-7536		A8A3MP36
5340-695-2558		A8A4MP74	5340-984-7536		A8A3MP37
5340-695-2558		A8A4MP75	5340-984-7537		A8A3MP3
5340-695-2558		A8A4MP76	5355-733-5548		A8A4MP43
5340-695-2558		A8A4MP77	5355-950-7574		A8A4MP45
5340-695-2558		A8A4MP78	5355-950-7575		A8A4MP42
5340-695-2558		A8A4MP79	5355-950-7576		A8A4MP44
5340-695-2558		A8A4MP80	5355-951-4083		A8A4A6MP48
5340-695-2558		A8A4MP81	5355-951-4083		A8A4A6MP49
5340-720-6320		A8A4MP20	5355-951-4083		A8A4A6MP50
5340-720-8064		A8A4A6H4	5355-965-4878		A5MP4
5340-734-5982		A6MP10	5820-015-1607		A8A3A2
5340-758-5660		A6MP5	5820-042-5719		A8A3E48
5340-758-5660		A6MP6	5820-062-4758		A7
5340-795-9364		A7A1MP3	5820-066-2122		A8A7TB1E1
5340-795-9364		A7A1MP4	5820-087-0328		A8A6
5340-795-9364		A7A2MP3	5820-087-2299		A8A1
5340-795-9364		A7A2MP4	5820-087-2304		A8A5
5340-803-2373		A8A4H10	5820-087-2314		A8A7
5340-803-2373		A8A4H11	5820-087-3439		A8A1E2
5340-803-2373		A8A4H12	5820-087-3440		A8A6A1
5340-803-2373		A8AMH7	5820-088-1379		A8A6E1
5340-803-2373		A8A4H8	5820-088-2514		A8A1E3
5340-803-2373		A8A4H9	5820-088-2515		A8A2E2
5340-947-6204		A6A1	5820-088-4936		A8A4E24
5340-947-6204		A6A2	5820-088-4916		A8A4E29
5340-975-7637		A8A1E4	5820-088-4916		A8A4E30

SECTION IV INDEX-FEDERAL STOCK NUMBER AND REFERENCE NUMBER CROSS REFERENCE TO FIGURE AND ITEM NUMBER OR REFERENCE DESIGNATION (CONTINUED)

FEDERAL STOCK NUMBER	FIGURE NUMBER	ITEM NUMBER OR REF. DESIGNATION	FEDERAL STOCK NUMBER	FIGURE NUMBER	ITEM NUMBER OR REF. DESIGNATION
5820-088-4916		A8A4E31	5820-975-5417	3-14	A8A7E4
5820-088-4916		A8A4E32	5820-975-5419	3-15	A8A7E5
5820-089-4996		A8A4A6A13	5820-975-5421	3-15	A8A7E1
5820-104-9512		A8A4A16	5820-975-5422	3-14	A8A7E6
5820-168-1583		A8A4E33	5820-975-5423	3-14	A8A7E2
5820-168-1598		A8A4A1	5820-975-5426	3-20	A8A2E1
5820-758-0063		A6A3	5820-975-5427	3-21	A8A2E3
5820-758-0064		A6MP7	5820-975-5428	3-21	A8A2E4
5820-788-9615		A5A1E1	5820-975-5429	3-21	A8A2E5
5820-795-9365		A8A3A12	5820-975-5430	3-9	A8A3E47
5820-795-9370		A7A1MP10	5820-975-5431	3-10	A8A3A13
5820-795-9370		A7A1MP11	5820-975-5432	3-10	A8A3E46
5820-795-9370		A7A2MP10	5820-975-5433	3-24	A8A3A9A1
5820-795-9370		A7AZP11	5820-975-7638		A8A3A8
5820-946-3338	3-19	A8A1E3E1	5820-975-7640		A8A3MP30
5820-946-3347	3-58	A8A7E5E1	5820-975-7641		A8A3MP29
5820-950-4464	3-11	A8A5E2	5820-975-7642		A8A3A7
5820-951-4081		A8A4E22	5820-975-7645		A8A7A2
5820-951-4081		A8A4E23	5820-975-7646		A8A7A3
5820-953-5772	3-60	A8A7E7A2	5820-976-9775		A8A4A6A11
5820-960-7832		A6MP8	5820-976-9776		A8A4A6A9
5820-960-7832		A6EP9	5820-976-9777		A8A4A6A10
5820-960-7844		A8A3E7	5820-977-1553		A8A4A6MP21
5820-960-7845	3-4	A8A3	5820-977-1558		A8A4A6A2
5820-960-7852	3-9	A8A3A4	5820-977-1558		A8A4A6MP38
5820-970-6766	1-7	A3	5820-977-1559		A8A4A6A4
5820-975-5412	3-6	A8A1E1	5820-977-1560		A8A4A6AP44
5820-975-5413	3-10	A8A3A11	5820-977-1561		A8A4A61AP45
5820-975-5414	3-10	A8A3A10	5820-977-1563		A8A4A6A1
5820-975-5415	3-24	A8A3A9A2	5820-977-1564		A8A4A6MP20
5820-975-5416	3-24	A8A3A9A3	5820-977-1565	3-10	A8A3A9

SECTION IV INDEX-FEDERAL STOCK NUMBER AND REFERENCE NUMBER CROSS REFERENCE TO FIGURE AND ITEM NUMBER OR REFERENCE DESIGNATION (CONTINUED)

FEDERAL STOCK NUMBER	FIGURE NUMBER	ITEM NUMBER OR REF. DESIGNATION	FEDERAL STOCK NUMBER	FIGURE NUMBER	ITEM NUMBER OR REF. DESIGNATION
5820-977-1566		A8A4A7	5841-514-2298		A8A41P95
5820-977-6238		A8A4MP40	5895-060-4825		A4A1EMP5
5820-977-6238		A8A4MP41	5895-984-1066		A4A1EMP1
5820-977-6242		A8A3MP39	5895-984-1067		A4A1EMP2
5820-977-6242		A8A3MP40	5895-984-1067		A4A1EMP3
5820-977-7650		A8A3MP13	5895-984-1067		A4A1EMP4
5820-977-7650		A8A3MP14	5895-984-1068		A4A1EMP6
5820-977-7651		A8A3MP5	5895-984-1069		A4A1EMP7
5820-977-7651		A8A3MP6	5895-984-1069		A4A1EMP8
5820-977-7652		A8A4A6MP18	5895-984-1069		A4A1EMP9
5820-977-7652		A8A4A6MP19	5905-033-9852	3-40	A8A3R20
5820-979-0033		A8A4E25	5905-068-1538	3-18	A8A1E2R30
5820-979-0033		A8A4E26	5905-068-1538	3-18	A8A1E2R6
5820-979-0033		A8A4E27	5905-068-1538	3-33	A8A3A4R157
5820-979-0033		A8A4E28	5905-070-9333	3-21	A8A2E5R40
5820-979-0034		A8A4MP36	5905-088-0635	3-45	A8A5R11
5820-981-5877	3-10	A8A3TB1	5905-104-8355		A8A4R125
5820-984-1770		A8A4A6A7	5905-221-5860	3-45	A8A5R12
5820-984-1798		A8A4MP90	5905-247-8732		A8A4R120
5820-984-1798		A8A4MP91	5905-251-6530		A8A4R11
5820-984-1799		A8A4E131	5905-252-1953	3-16	A8A1R82
5905-279-1745	3-16	A8A4R84			
5820-984-2139		A8A4A15	5905-279-3521	3-16	A8AIR81
5820-984-7544	3-67	A8A4TB6	5905-299-2004		A8A4A7R107
5820-995-6535		A8A3TB2	5905-299-2004	3-48	A8A5E2R17
5820-996-5812	3-15	A8A7TB1	5905-484-0278	3-64	A8A4.RI12
5821-019-6291	3-12	A8A6E2	5905-484-0278	3-64	A8A4R113
5821-561-6371		A8A4A6A1MP3	5905-484-0278	3-64	A8A4R114
5821-561-6371		A8A4A6AC9P3	5905-681-8822	3-55	A8A7E2R49
5821-658-3718		A8A4MP15	5905-681-8822	3-55	A8A7E2R68
5841-514-2298		A8A4MP92	5905-682-1379	3-11	A8A5R4
5841-514-2298		A8A4MP93	5905-682-4109	3-21	A8A2E3R36
5841-514-2298		A8A4MP94	5905-682-4109	3-21	A8A2E3R37

SECTION IV INDEX-FEDERAL STOCK NUMBER AND REFERENCE NUMBER CROSS REFERENCE TO FIGURE AND ITEM NUMBER OR REFERENCE DESIGNATION (CONTINUED)

FEDERAL STOCK NUMBER	FIGURE NUMBER	ITEM NUMBER OR REF. DESIGNATION	FEDERAL STOCK NUMBER	FIGURE NUMBER	ITEM NUMBER OR REF. DESIGNATION
5905-682-4109	3-38	A8A3E47R139	5905-816-8554	3-53	A8A6A1R32
5905-682-4109	3-38	A8A3E47R144	5905-816-8554	3-52	A8A6E1P35
5905-682-4109	3-38	A8A3E47R28	5905-816-8554	3-52	A8A6E1R37
5905-682-4109	3-38	A8A3E47R37	5905-816-8554	3-52	A8A6E1R41
5905-682-4109	3-38	A8A3E47R54	5905-816-8554	3-52	A8A6E1R42
5905-726-6431	3-19	A8A1E3R50	5905-816-8554	3-52	A8A6E2R10
5905-752-3335	3-19	A8A1E3R72	5905-816-8554	3-52	A8A6E2R11
5905-754-9142	3-20	A8A2E1R5	5905-816-8554	3-52	A8A6E2R14
5905-781-8015	3-55	A8A7E2R42	5905-816-8554	3-52	A8A6E2R15
5905-781-8015	3-55	A8A7E2R62	5905-816-8554		A8A6R30
5905-781-8015	3-56	A8A7TB1R149	5905-816-8554		A8A6R45
5905-816-8554	3-18	A8A1E2R19	5905-816-8554		A8A6R46
5905-816-8554	3-19	A8A1E3R47	5905-816-8554	3-54	A8A7E1R23
5905-816-8554	3-19	A8A1E3R53	5905-816-8554	3-54	A8A7E1R26
5905-816-8554	3-19	A8A1E3R64	5905-816-8554	3-54	A8A7E1R3
5905-816-8554	3-19	A8A1E3R68	5905-816-8554	3-55	A8A7E2R41
5905-816-8554	3-20	A8A2E2R14	5905-816-8554	3-55	A8A7E2R61
5905-816-8554	3-21	A8A2E3P24	5905-816-8554	3-56	A8A7TB1R127
5905-816-8554	3-21	A8A2E4R31	5905-827-0724	3-16	A8A1R80
5905-816-8554	3-21	A8A2E4R39	5905-8q2-6578	3-34	A8A3A4R163
5905-816-8554	3-20	A8A2R27	5905-952-9232	3-67	A8A4R8
5905-816-8554	3-38	A8A3E47R25	5905-969-5849	3-54	A8A7E1R10
5905-816-8554	3-38	A8A3E47R44	5905-982-3329	3-45	A8A5R24
5905-816-8554	3-38	A8A3E47R48	5905-985-5435	3-20	A8A2E1R2
5905-816-8554	3-38	A8A3E47R56	5905-985-5435	3-34	A8A3A4R164
5905-816-8554	3-39	A8A3E48R97	5905-985-5465	3-67	A8A4R126
5905-816-8554	3-40	A8A3R17	5Q05-985-5465	3-56	A8A7TB1R150
3905-816-8554	3-22	A8A3TB1R1	5905-988-2310	3-56	A8A7TB1P125
5905-816-8554	3-23	A8A3TB2R9	5905-988-2310	3-56	48A7TP1R126
5905-816-8554	3-53	A8A6A1R23	5905-988-2310	3-56	A8A7TB1P132
5905-816-8554	3-53	A8A6A1R28	5905-988-2310	3-56	A8A7TB1R133
5905-816-8554	3-53	A8A6A1R31	5905-990-2246	3-33	A8A3A4R156
5905-990-4151	3-67	A8A4TB1P2			

SECTION IV INDEX-FEDERAL STOCK NUMBER AND REFERENCE NUMBER CROSS REFERENCE TO FIGURE AND ITEM NUMBER OR REFERENCE DESIGNATION (CONTINUED)

FEDERAL STOCK NUMBER	FIGURE NUMBER	ITEM NUMBER OR REF. DESIGNATION	FEDERAL STOCK NUMBER	FIGURE NUMBER	ITEM NUMBER OR REF. DESIGNATION
5910-023-2068		A8A6C14	5910-456-0793		A8A6C29
5910-023-2068		A8A6C20	5910-456-0793		A8A6C34
5910-023-2068		A8A6C23	5910-456-0797	3-21	A8A2E3C12
5910-023-2068		A8A6C29	5910-456-0797		A8A6C14
5910-023-2068		A8A6C34	5910-456-0797		A8A6C20
5910-051-4612	3-20	A8A2E1C36	5910-456-0797		A8A6C23
5910-051-4612		A8A6C14	5910-456-0797		A8A6C29
5910-051-4612		A8A6C20	5910-456-0797		A8A6C34
5910-051-4612		A8A6C23	5910-456-0797	3-59	A8A7E6C103
5910-051-4612		A8A6C29	5910-519-6789	3-64	A8A4A16C118
5910-051-4612		A8A6C34	5910-544-7003	3-64	A8A4A16C116
5910-051-4612	3-57	A8A7E4C66	5910-544-7003	3-64	A8A4A16C117
5910-051-4612	3-57	A8A7E4C68	5910-649-1438	3-45	A8A5C16
5910-051-4612	3-57	A8A7E4C70	5910-649-7756	3-41	A8A3C344
5910-668-3647	3-64				A8A4C123
5910-064-4697	3-34	A8A3A4C327	5910-683-7114	3-60	A8A7E7A2C113
5910-069-0376	3-34	ASA3A4C321	5910-683-7114	3-60	A8A7E7A2C115
5910-080-1713	3-41	A8A3C188	5910-683-7114	3-60	A8A7E7A2C117
5910-080-1713	3-41	A8A3C289	5910-683-7114	3-60	A8A7E7A2C119
5910-080-1713	3-41	A8A3C290	5910-683-7114	3-60	A8A7E7A2C121
5910-080-1713	3-41	ASA3C291	5910-683-7114	3-60	A8A7E7A2C123
5910-080-1713	3-23	A8A3TB2C89	5910-683-7114	3-60	A8A7E7A2C125
5910-080-1713	3-23	A8A3TB2C90	5910-683-7114	3-60	ASA7E7A2C127
5910-080-1713		A8A4C28	5910-683-7114	3-60	A8A7E7A2C129
5910-102-1346	3-53	A8A6A1C18	5910-683-7114	3-60	A8A7E7A2C131
5910-102-1346	3-53	A8A6A1C23	5910-683-7114	3-60	ASA7E7A2C133
5910-102-1346	3-53	A8A6A1C26	5910-683-7114	3-60	A8A7E7A2C135
5910-115-3567		A8A4C145	5910-683-7114	3-60	A8A7E7A2C137
5910-118-7937	3-34	A8A3A4C349	5910-683-7114	3-60	A8A7E7A2C139
5910-244-1622	3-33	A8A3A4C338	5910-683-7114	3-60	A8A7E7A2C141
5910-456-0793		A8A6C14	5910-683-7114	3-60	A8A7E7A2C143
5910-456-0793		A8A6C20	5910-683-7114	3-60	A8A7E7A2C145
5910-456-0793		A8A6C23	5910-683-7114	3-60	ASA7E7A2C147

SECTION IV INDEX-FEDERAL STOCK NUMBER AND REFERENCE NUMBER CROSS REFERENCE TO FIGURE AND ITEM NUMBER OR REFERENCE DESIGNATION (CONTINUED)

FEDERAL STOCK NUMBER	FIGURE NUMBER	ITEM NUMBER OR REF. DESIGNATION	FEDERAL STOCK NUMBER	FIGURE NUMBER	ITEM NUMBER OR REF. DESIGNATION
5910-683-7114	3-60	A8A7E7A2C149	5910-825-3067		A8A6C23
5910-683-7114	3-60	A8A7E7A2C151	5910-825-3067		A8A6C29
5910-683-7276	3-20	A8A3C37	5910-825-3067		A8A6C34
5910-688-6457	3-41	A8A3A2C350	5910-825-3067	3-58	A8A7E5C83
5910-688-6457	3-41	A8A3A2C351	5910-825-5288		A8A6C14
5910-688-6457	3-41	A8A3A2C352	5910-825-5288		A8A6C20
5910-762-2828	3-40	A8A3C117	5910-825-5288		A8A6C23
5910-762-2828	3-40	A8A3C292	5910-825-5288		A8A6C29
5910-765-4415	3-40	A8A3C118	5910-825-5288		A8A6C34
5910-765-4419	3-17	A8A1E1C25	5910-825-5288	3-58	A8A7E5C89
5910-765-4419	3-19	A8A1E3C37	5910-827-0019	3-19	A8A1E3C32
5910-765-4419	3-19	A8A1E3C38	5910-827-0019	3-19	A8A1E3C36
5910-765-4419	3-19	A8A1E3C41	5910-851-3328		A8A6C14
5910-780-8675	3-50	A8A5C25	5910-851-3328		A8A6C20
5910-780-8675	3-45	A8A5C27	5910-851-3328		A8A6C23
5910-780-8675	3-45	A8A5C28	5910-851-3328		A8A6C29
5910-780-8675	3-45	A8ASC29	5910-851-3328		A8A6C34
5910-808-8971	3-17	A8A1E1C26	5910-878-5239		A8A6C14
5910-809-5679	3-17	A8A1E1C26	5910-878-5239		A8A6C20
5910-814-0419		A8A6C14	5910-878-5239		A8A6C23
5910-814-0419		A8A6C20	5910-878-5239		A8A6C29
5910-814-0419		A8A6C23	5910-878-5239		A8A6C34
5910-814-0419		A8A6C29	5910-889-4562	3-64	A8A4C146
5910-814-0419		A8A6C34	5910-901-6105	3-53	A8A6AIC15
5910-824-8036	3-20	A8A2E1C36	5910-901-6105	3053	A8A6AIC16
5910-824-8036		A8A6C14	5910-936-7372		A8A6C14
5910-824-8036		A8A6C20	5910-936-7372		A8A6C20
5910-824-8036		A8A6C23	5910-936-7372		A8A6C23
5910-824-8036		A8A6C29	5910-936-7372		A8A6C29
5910-824-8036		A8A6C34	5910-936-7372		A8A6C34
5910-825-3067		A8A6C14	5910-945-0313	3-53	A8A6A1C22
5910-825-3067		A8A6C20	5910-954-3038	3-11	A8ASC19A

SECTION IV INDEX-FEDERAL STOCK NUMBER AND REFERENCE NUMBER CROSS REFERENCE TO FIGURE AND ITEM NUMBER OR REFERENCE DESIGNATION (CONTINUED)

FEDERAL STOCK NUMBER	FIGURE NUMBER	ITEM NUMBER OR REF. DESIGNATION	FEDERAL STOCK NUMBER	FIGURE NUMBER	ITEM NUMBER OR REF. DESIGNATION
5910-954-3038	3-11	A8A5C19B	5910-964-6511	3-58	A8A7E5C91
5910-954-5496	3-36	A8A3A13C263	5910-966-9460	3-67	A8A4C29
5910-954-5496	3-26	A8A3A9A1C10	5910-966-9460	3-67	A8A4C30
5910-954-5496	3-38	A8A3E47C180	5910-968-5427	3-45	A8A5C26
5910-954-5496		AA6C14	5910-995-0614	3-39	A8A3E48C167
5910-954-5496		A8A6C20	5910-995-0614	3-39	A8A3E48C170
5910-954-5496		A8A6C23	5910-995-0614	3-39	A8A3E48C172
5910-954-5496		A8A6C29	5910-995-0614	3-56	A8A7TB1C167
5910-954-5496		A8A6C34	5910-995-0614	3-56	A8A7TB1C176
5910-954-5496	3-54	A8A7E1C2	5915-846-0453	3-21	A8A2FL1
5910-954-5497	3-58	A8A7E5C77	5915-904-7529	3-67	A8A4FL2
5910-954-5497	3-56	A8A7B1C17	5920-060-2424		ASA4F2
5910-954-5497	3-56	A8A7TB1C173	5910-168-1402	3-67	A8A4TB9
5910-954-5497	3-56	AA7TB1C175	5920-280-3562		AS8AF1
5910-954-5504	3-39	A8A3E48C168	5920-280-8344	3-67	A8A4F3
5910-954-5504		A8A6C14	5920-356-2185	3-67	A8A4F5
5910-954-5504		A8A6C20	5920-728-3487		A8A4XF1
5910-954-5504		A8A6C23	5920-728-3487		A8A4XF2
5910-954-5504		A8A6C29	5930-078-1717	3-33	A8A3A4S10
5910-954-5504		A8A6C34	5930-578-9817		ASA4S2
5910-957-8578		A8A6C14	5930-636-1425	3-65	A8A4KI03
5910-957-8578		A8A6C20	5930-820-9131	3-65	A8A4S102
5910-957-8578		A8A6C23	5930-893-192 8		A8A4S3H1
5910-957-8578		A8A6C29	5930-960-7842	3-34	A8A3A4S7
5910-957-8578		A8A6C34	5930-981-5868		A8A4S1
5910-960-7298	3-34	A8A3A4C340	5930-981-5883		A8A3A13S9
5910-964-6511	3-20	A8A2E1C36	5930-987-8798		A8A7E5E4
5910-964-6511		A8A6C14	5930-999-9195		A8A4S3
5910-964-6511		A8A6C20	5935-027-2636	3-9	A8A3AIJ1
5910-964-6511		A8A6C23	5935-034-1097		A8A5P1AI
5910-964-6511		A8A6C29	5935-034-1097		A8A5P1A2
5910-964-6511		A8A6C34	5935-081-2270	3-67	A8AJ4

SECTION IV INDEX-FEDERAL STOCK NUMBER AND REFERENCE NUMBER CROSS REFERENCE TO FIGURE AND ITEM NUMBER OR REFERENCE DESIGNATION (CONTINUED)

FEDERAL STOCK NUMBER	FIGURE NUMBER	ITEM NUMBER OR REF. DESIGNATION	FEDERAL STOCK NUMBER	FIGURE NUMBER	ITEM NUMBER OR REF. DESIGNATION
5935-081-2270	3-67	A8A4J9	5935-807-8202	3-16	A8A4P1
5935-088-6228		A2J1	5935-808-7502		A8A1P1
5935-088-6228	3-12	A2J2	5935-811-1382	3-21	A8A2P4
5935-432-6422		A8A6A1AIJ2	5935-811-1382	3-52	A8A6P1
5935-432-6473	3-53	A8A6A1A1J3	5935-840-548 5	3-45	A8A5XC19
5935-549-2646		A8A4P2	5935-840-5485	3-45	AA5XC20
5935-549-2646	3-9	A8A4P3	5935-883-0218	3-67	A8A4J2
5935-683-7648		A8A3A1J3	5935-885-6505		A8A2P3A1
5935-683-7649	3-9	A8A3A1J4	5935-885-6505	A8A2P4A1	
5935-733-6655		A8A4J10A1	5935-885-6505	A8A2P4A2	
5935-733-6655		A8A4J10A2	5935-885-6505	A8A3P1A1	
5935-733-6655		ABA4J10A3	5935-885-6505	A8A3P1A2	
5935-733-6655		A8A4J11A1	5935-885-6505	A8A3P2A1	
5935-733-6655		A8AJ11A2	5935-885-6505	A8A3P2A2	
5935-733-6655		A8A4J3A2	5935-885-6505	A8A3P3A1	
5935-733-6655		A8A4J4A1	5935-885-6505	A8A3P3A2	
5935-733-6655		A8A4J4A2	5935-885-6505	A8A3P4A1	
5935-733-6655		A8A4J4A3	5935-885-6505	A8A3P4A2	
5935-733-6655		A8A4J5A1	5935-885-6505	A8A6P1A1	
5935-733-6655		A8A4J5A2	5935-885-6505	A8A6P1A2	
5935-733-6655		A8A4J6A1	5935-885-6505	A8A6P1A3	
5935-733-6655		A8A4J6A2	5935-885-6505	A8A7P1A1	
5935-733-6655		A8A4J7A1	5935-885-6505	A8A7P1A2	
5935-773-6655		A8A4J7A2	5935-885-6505	A8A7P2A1	
5935-733-6655		A8A4J8A1	5935-885-6505	ABA7P2A2	
5935-733-6655		A8A4J8A2	5935-885-6505	A8A7P2A3	
5935-733-6655		A8A4J9A1	5935-885-6508	A8A2P4A3	
5935-733-6655		A8A4J9A2	5935-892-9923	A8A4E14	
5935-733-6655		A8A4J9A3	5935-892-9923	A8A4E15	
5935-766-6465	3-11	ABA5A1J10	5935-892-9923	A8A4E16	
5935-773-8947		A8A4E20	5935-892-9923	A8A4E17	
5935-773-8947		A8A4E21	5935-892-9923	A8A4E18	

SECTION IV INDEX-FEDERAL STOCK NUMBER AND REFERENCE NUMBER CROSS REFERENCE TO FIGURE AND ITEM NUMBER OR REFERENCE DESIGNATION (CONTINUED)

FEDERAL STOCK NUMBER	FIGURE NUMBER	ITEM NUMBER OR REF. DESIGNATION	FEDERAL STOCK NUMBER	FIGURE NUMBER	ITEM NUMBER OR REF. DESIGNATION
5935-892-9923		A8A4E19	5940-455-7441		A8A3E39
5935-951-3054		A2MP3	5940-455-7441		ASA3E40
5939-951-4052	3-11	A8A5A1J6	5940-455-7441		A8A3E41
5935-951-4053	3-11	A8A5A1J7	5940-455-7441		A8A3E42
5935-951-7196	3-67	A8A4J1	5940-455-7441		A8A3E43
5935-954-4470	3-11	A8A5A1J9	5940-455-7441		A8A3E44
5935-960-7324	3-11	A8A5A1J8	5940-455-7441		A8A4E53
5935-977-6239		A8A4J1A1	5940-501-5832		A5E3
5935-977-6239		A8A4J1A2	5940-501-8634		A8A3E139
5935-988-4769	3-11	A8A5A1J5	5940-665-5764		A8A3E45
5940-056-8696		A8A4MP82	5940-665-5764		A8A3E46
5940-056-8696		A8A4MP83	5940-700-2953		A8A4E55
5940-061-0050		A8A4E150	5940-700-2953		A8A4E56
5940-061-0050		A8A4E151	5940-700-2953		A8A4E57
5940-061-0050		A8A4E152	5940-728-3622		A8A4E12
5940-061-0050		A8A4E153	5940-728-3622		A8A4E13
5940-061-0050		A8A4E154	5940-836-3536		A8A2E6
5940-061-0050		A8A4E160	5940-836-3536		ASA2E7
5940-061-0050		A8A4E167	5940-836-3536		A8A2E8
5940-061-0050		A8A4E168	5940-836-3536		A8A3E37
5940-255-3907		A8A5E18	5940-836-3536		A8A4E44
5940-259-8457		A8A3E10	5940-836-3536		ASA4E45
5940-259-8457		A8A4E7	5940-836-3536		ASA4E46
5940-259-8457		A8A4E8	5940-836-3536		A8A4E47
5940-259-8457		A8A5E10	5940-836-3536		A8A4E48
5940-259-8457	3-45	A8A5E11	5940-836-3536		A8A4E49
5940-259-8457		A8A4E7	5940-836-3536		A8A4E50
5940-259-8457	3-45	A8A5E8	5940-836-3536		A8A4E51
5940-259-8457		A8A5E9	5940-836-3536		A8A4E52
5940-259-8457		A8A7E9	5940-877-8430		A8A4E1
5940-455-7441		A8A2E9			
5940-455-7441		A8A3E38	5940-877-8430		A8A4E2

SECTION IV INDEX-FEDERAL STOCK NUMBER AND REFERENCE NUMBER CROSS REFERENCE TO FIGURE AND ITEM NUMBER OR REFERENCE DESIGNATION (CONTINUED)

FEDERAL STOCK NUMBER	FIGURE NUMBER	ITEM NUMBER OR REF. DESIGNATION	FEDERAL STOCK NUMBER	FIGURE NUMBER	ITEM NUMBER OR REF. DESIGNATION
5940-877-8430		A8A4E3	5950-960-7338	3-56	A8A7TB1T3
5940-877-8430		A8A4E4	5950-960-7339	3-56	A8A7TB1T2
5940-877-8430		A8A4E5	5950-960-7339	3-56	A8A7B1T4
5940-877-8430		A8A4E6	5950-960-7841	3-33	A8A3A4S6
5940-903-5951		A8A4E54	5950-960-7848	3-33	A8A3A4A2
5940-984-1791	3-67	A8A4TB4	5950-960-7850	3-41	A8A3L145
5945-105-4267		A8A4K6	5950-960-7859	3-32	A8A3A4A2L143
5945-889-1179		A8A4K101	5950-978-6204	3-64	A8AL111
5945-889-1180	3-65	A8A4K102	5950-978-6205	3-64	A8A1L110
5945-983-9145	3-67	A8A4K1	5950-982-3748	3-11	ASA5T1
5945-983-9145	3-67	A8A4K3	5950-984-1111	3-67	A8A4T1
5945-983-9145	3-67	A8A4K4	5950-984-1787	3-29	A8A3A10E5
5945-983-9145	3-67	ASA4K5	5950-984-1787	3-30	A8A3A11E7
5945-984-1796	3-50	A8A5K1	5950-984-1787	3-35	A8A3A12E11
5950-044-2428	3-41	A8A3L5	5950-984-1787	3-24	A8A3A9A2E1
5950-044-2429	3-41	A8A3L4	5950-984-1787	3-28	A8A3A9A3E3
5950-703-0907	3-67	A8A4L1	5950-984-2278	3-45	A8A5L1
5950-703-0907	3-67	A8A4L2	5950-987-8827	3-67	A8A4T3
5950-703-0907	3-67	A8A4L3	5950-988-3058	3-65	A8A4L112
5950-798-2558	3-67	A8A4L4	5950-988-3059	3-65	A8A4L109
5950-809-9357	3-64	A8A4T101	5955-950-8569	3-60	A8A7E7A2Y12
5950-812-0292	3-16	A8A1T2	5960-617-5785		A8A3MP31
5950-828-1336	3-53	A8A6A1L5	5960-960-7338	3-56	A8A7TB1T1
5950-828-1343	3-61	A8A7L34	5960-984-0422		A8A4MP37
5950-828-1343	3-61	A8A7L35	5961-945-5436	3-67	A8A4Q1
5950-828-1343	3-61	A8A7L36	5961-945-5436	3-67	A8A4Q2
5950-828-1343	3-61	A8A7L37	5961-960-7835	3-34	A8A3A4CR10
5950-950-4176	3-41	A8A3L1	5961-960-7835	3-34	A8A3A4CE9
5950-950-4176	3-41	A8A3L2	5961-953-4485	3-33	A8A3A4Q20
5950-950-4176	3-41	A8A3L3	5961-953-4485	3-33	A8A3A4Q21
5950-951-1391	3-16	A8A1T3	5961-975-2158		A8A4TB6CR1
5950-951-7181	3-16	A8A1T5	5965-985-3589		HT1

SECTION IV INDEX-FEDERAL STOCK NUMBER AND REFERENCE NUMBER CROSS REFERENCE TO FIGURE AND ITEM NUMBER OR REFERENCE DESIGNATION (CONTINUED)

FEDERAL STOCK NUMBER	FIGURE NUMBER	ITEM NUMBER OR REF. DESIGNATION	FEDERAL STOCK NUMBER	FIGURE NUMBER	ITEM NUMBER OR REF. DESIGNATION
5970-143-3596		A8A1Q11H3	6740-618-6314		A8A4MP9
5971-117-5012		A5E4	<u>REF NO.</u>	<u>MFG CO.</u>	<u>FIG NO.</u> ITEM NO. OR REF DES.
5971-117-5012		A5E5	AB396-1	12615	A8A6A1E1
5975-727-5153		A8A4MP21	AB396-1	12615	A8A6A1E2
5975-836-3373		A8A4S102H1	AB396-1	12615	A8A6A1E3
5975-836-3373		A8A4S2H1	AB396-1	12615	A8A6A1E4
5975-987-8829		A8A4R1H	AB396-1	12615	A8A6A1E5
5975-987-8829		A8A4S1H1	AB396-1	12615	
5975-987-8830	1-1	A4A1MP1	AB396-1	12615	A8A6E1E1
5985-087-2305	1-7	A5	AB396-1	12615	A8A6E1E2
5985-087-2326	1-1	A4	AB396-1	12615	A8A6E1E3
5985-987-9019		A8A4A6MP1	AB396-1	12615	A8A6E1E4
5995-082-0487	1-7	W2	AB396-1	12615	A8A6E1E5
5995-087-2324	1-7	W1	AB396-1	12615	A8A6E1E6
5995-087-2325	1-1	W3	AB396-1	12615	A8A6E3
6110-960-7341	3-50	A8A5TB1	AB397-1A	12615	A8A3A4AE10
6130-088-1380	3-45	A8A5E3	AB397-1A	12615	A8A3A4A1E11
6130-088-1381	3-11	A8A5E1	AB397-1A	12615	A8A3A4A1E12
6135-087-2301		A2	AB397-1A	12615	A8A3A4A1E9
6145-191-8397		A7A1E1W1	AB397-1A	12615	A8A3A4A2E10
6145-191-8397		A7A2E1W1	AB397-1A	12615	A8A3A4A2E11
6210-736-7715		A8A4MP58	AB397-1A	12615	A8A3A4A2E12
6210-736-7715		A8A4MP59	AB397-1A	12615	A8A3A4A2E9
6210-791-9380		A8A4MP51	AB397-2	12615	A8A7TB1E10
6210-791-9380		A8A4UP52	AB397-2	12615	A8A7TB1E11
6240-155-7836		A8A4DS1	AB397-2	12615	A8A7TB1E12
6240-155-7836		A8A4DS101	AB397-2	12615	A8A7TB1E13
6240-155-7836		A8A4DS102	AB397-2	12615	A8A7TB1E14
6240-155-7836		A8A4DS2	AB397-2	12615	A8A7TB1E15
6250-984-1092		A8A4A2	AB397-2	12615	A8A7TB1E16
6625-757-4344		A5E3	AB397-2	12615	A8A7TB1E17
6625-984-1076		A8A4M101	AB397-2	12615	A8A7TB1E18

SECTION IV INDEX-FEDERAL STOCK NUMBER AND REFERENCE NUMBER CROSS REFERENCE TO FIGURE AND ITEM NUMBER OR REFERENCE DESIGNATION (CONTINUED)

FEDERAL STOCK NUMBER	FIGURE NUMBER	ITEM NUMBER OR REF. DESIGNATION	FEDERAL STOCK NUMBER	FIGURE NUMBER	ITEM NUMBER OR REF. DESIGNATION
<u>REF NO.</u>	<u>MFG CO.</u>	<u>FIG NO.</u> <u>ITEM NO. OR REF DES.</u>			
AB397-2	12615	A8A7TB1E2			
AB397-2	12615	A8A7TB1E3			
AB397-2	12615	A8A7TB1E4			
AB397-2	12615	ASA7TB1E5			
AB397-2	12615	A8A7TB1E6			
AB397-2	12615	A8A7TB1E7			
AB397-2	12615	A8A7TB1E8			
AB397-2	12615	A8A7TB1E9			
AGC250-1-500	71400	3-67 A8A4F4			
AG5-1-1-2Z	00656	3-64 A8A4A6C105			
AM3506PRC47	80058	3-4 A8A1			
AM3507PRC47	80058	3-4 A8AQ			
ANPRC47	80058	1-1			
AN960-616L	88044	ASA4A7H2			
ARP567-009	83259	A8A4MP28			
ARP567-009	83259	A8A4MP29			
AS1320PRC47	80058	1-1 A4			
AS1321PRC47	80058	1-7 A5			
A12408	70674	3-45 A8A5L1			

**SECTION IV. INDEX-FEDERAL STOCK NUMBER & REFERENCE NUMBER CROSS-REFERENCE
TO FIGURE & ITEM NUMBER (Continued)**

FEDERAL STOCK NUMBER	FIGURE NUMBER		ITEM NUMBER OR REF. DESIGNATION	FEDERAL STOCK NUMBER	FIGURE NUMBER		ITEM NUMBER OR REF. DESIGNATION	FEDERAL STOCK NUMBER	FIGURE NUMBER		ITEM NUMBER OR REF. DESIGNATION
	MFG CO.	FIG NO.			MFG CO.	FIG NO.			MFG CO.	FIG NO.	
REF NO.	MFG CO.	FIG NO.	ITEM NO OR REF DES.	REF NO.	MFG CO.	FIG NO.	ITEM NO OR REF DES.	REF NO.	MFG CO.	FIG NO.	ITEM NO OR REF DES.
A12425	70674	3-16	A8A1T2	CK104	71590		A8A4FL2C230	CK60AW102M	81349		A8A4C21
A12426	70674	3-16	A8A1T3	CK104	71590		A8A4FL2C234	CK60AW102M	81349		A8A4C22
A12808	70671	3-16	A8A1T5	CK104	71590		A8A4FL2C235	CK60AW102M	81349		A8A4C23
A51003	08289		A8A5TB1MP2	CK104	71590		A8A4FL2C237	CK60AW102M	81349		A8A4C24
A51043	08289		A8A5TB1MP3	CK12BX472K	81349	3-53	A8A6A1C18	CK60AW102M	81349		A8A4C25
A51048	08289		A8A7E2MP1	CK12BX472K	81349	3-53	A8A6A1C23	CK60AW102M	81349	3-47	A8A5E1C18
A51048	08289		A8A7E2MP2	CK12BX472K	81349	3-53	A8A6A1C26	CK60AW102M	81349	3-47	A8A5E1C21
A51048	08289		A8A7E6MP1	CK13AX222M	81349	3-53	A8A6A1C22	CL21BQ040SPE	81349	3-20	A8A2E1C4
BC3069	97315	3-11	A8A5T1	CK13BX103K	81349	3-52	A8A6E1C35	CL23BE400UNE	81349	3-20	A8A2E2C5
BC3072	97315	3-67	A8A4T1	CK13BX103M	81349	3-21	A8A2C33	CL24BJ180TP3	81349		A8A4C145
BP906	99800	3-64	A8A4L106	CK13BX103M	81349	3-33	A8A3A4C318	CL26BJ2R5TN3	81349	3-19	A8A1E3C29
BR7X300D2S2-26V	09026		A8A4K2	CK13BX103M	81349	3-33	A8A3A4C319	CM04CD010D03	81349		A8A6E2C13
B2A440-9C1	08664		A8A4MP22H2	CK13BX103M	81349	3-34	A8A3A4C334	CM04CD010D03	81349	3-52	A8A6E2C9
B2A440-9C1	00864		A8A4MP23H2	CK13BX103M	81349	3-33	A8A3A4C335	CM04CD010DC3	81349	3-55	A8A7E2C200
CC20CH120J	81349	3-25	A8A3A9A2C32	CK13BX103M	81349	3-33	A8A3A4C336	CM04CD010D03	81349	3-55	A8A7E2C201
CC20CH180J	81349	3-25	A8A3A9A2C31	CK13BX103M	81349	3-33	A8A3A4C343	CM04CD050D03	81349	3-32	A8A3A4A6C299
CC20UJ510F	81349	3-29	A8A3A10C85	CK13BX103M	81349	3-66	A8A4A1C125	CM04CD050D03	81349	3-32	A8A3A4A2C301
CC20UJ510F	81349	3-35	A8A3A12C139	CK13BX103M	81349	3-66	A8A4A1C126	CM04CD050D03	81349	3-32	A8A3A4A2C303
CC20UJ510F	81349	3-35	A8A3A12C141	CK13BX103M	81349		A8A4A7A1C107	CM04CD050D03	81349	3-32	A8A3A4A2C315
CC20UJ510F	81349	3-28	A8A3A9A3C60	CK13BX103M	81349	3-56	A8A7TB1C160	CM04CD050D03	81349	3-32	A8A3A4A2C317
CC20UJ620F	81349	3-30	A8A3A11C112	CK13BX103M	81349	3-56	A8A7TB1C161	CM04CD050D03	81349	3-33	A8A3A4C341
CC20UJ620F	81349	3-30	A8A3A11C114	CK13BX103M	81349	3-56	A8A7TB1C162	CM04CD050D03	81349		A8A6E2C13
CC30UJ680F	81349	3-25	A8A3A9A2C28	CK13BX103M	81349	3-56	A8A7TB1C163	CM04CD050D03	81349	3-52	A8A6E2C9
CC30UJ680F	81349	3-28	A8A3A9A3C58	CK13BX103M	81349	3-56	A8A7TB1C164	CM04CD050D03	81349	3-55	A8A7E2C200
CC30UJ7500F	81349	3-29	A8A3A110C87	CK13BX103M	81349	3-56	A8A7TB1C165	CM04CD050D03	81349	3-55	A8A7E2C201
CC30UJ750F	81349	3-25	A8A3A9A2C30	CK13BX103M	81349	3-56	A8A7TB1C166	CM04CD100D03	81349	3-33	A8A3A4C339
CF75961	23675		A4A1E1MP2	CK13BX103M	81349	3-56	A8A7TB1C177	CM04CD100D03	81349		A8A6E2C13
CF75961	23675		A4A1E1MP3	CK14BX223M	81349	3-37	A8A3E46C276	CM04CD100D03	81349	3-52	A8A6E2C9
CF75961	23675		A4A1E1MP4	CK14BX223M	81349	3-37	A8A3E46C281	CM04CD100D03	81349	3-55	A8A7E2C200
CF75971	23675		A4A1E1MP6	CK14BX223M	81349	3-38	A8A3E47C144	CM04CD0100D3	81349	3-55	A8A7E2C201
CF75981	23675		A4A1E1MP7	CK14BX223M	31349	3-38	A8A3E47C153	CM04CD120J03	81349	3-31	A8A3A4A1C305
CF75981	23675		A4A1E1MP8	CK14BX223M	81349	3-22	A8A3TB1C63	CM04CD120J03	81349	3-31	A8A3A4A1C307
CF75981	23675		A4A1E1MP9	CK14BX223M	81349	3-22	A8A3TB1C66	CM04CD120J03	81349	3-31	A8A3A4A1C309
CF75991	23675		A4A1E1MP5	CK14BX223M	81349	3-67	A8A4C2	CM04CD120J03	81349	3-31	A8A3A4A1C311
CF76991	23675		A4A1E1MP1	CK14BX223M	81349	3-52	A8A6E1C32	CM04CD120J03	81349	3-31	A8A3A4A1C313
CH474PRC47	80058		A8A4	CK15BX104M	81349	3-41	A8A3C189	CM04CD120J03	81349		A8A6E2C13
CK104	71590		A8A4FL2C227	CK60AW102M	81349	3-21	A8A2E3C30	CM04CD120J03	81349	3-52	A8A6E2C9
CK104	71590		A8A4FL2C229	CK60AW102M	81349		A8A4C20	CM04CD150J03	81349	3-31	A8A3A4A1C305

**SECTION IV. INDEX-FEDERAL STOCK NUMBER & REFERENCE NUMBER CROSS-REFERENCE
TO FIGURE & ITEM NUMBER (Continued)**

FEDERAL STOCK NUMBER	FIGURE NUMBER		ITEM NUMBER OR REF. DESIGNATION	FEDERAL STOCK NUMBER	FIGURE NUMBER		ITEM NUMBER OR REF. DESIGNATION	FEDERAL STOCK NUMBER	FIGURE NUMBER		ITEM NUMBER OR REF. DESIGNATION
	MFG CO.	FIG NO.			MFG CO.	FIG NO.			MFG CO.	FIG NO.	
REF NO.	MFG CO.	FIG NO.	ITEM NO OR REF DES.	REF NO.	MFG CO.	FIG NO.	ITEM NO OR REF DES.	REF NO.	MFG CO.	FIG NO.	ITEM NO OR REF DES.
CM04CD150J03	81349	3-31	A8A3A4A1C307	CM0LED270G03	81349	3-32	A8A3A4A2C315	CM04FD101F03	81349	3-32	A8A3ALA2C299
CM04CD150J03	81349	3-31	A8A3A4A1C309	CM04ED270G03	81349	3-32	A8A3A4A2C317	CM04FD101F03	81349	3-32	A8A3A4A2C301
CM04CD150J03	81349	3-31	A8A3A4A1C311	CM04ED300G03	81349	3-31	A8A3A4A1C312	CM04FD101F03	81349	3-32	A8A3A4A2C303
CM04CD150J03	81349	3-31	A8A3A4A1C313	CM04ED360G03	81349	3-34	A8A3A4C329	CM04FD101F03	81349	3-32	A8A3A4A2C315
CM04CD150J03	81349	3-32	A8A3A4A2C299	CM04ED360G03	81349	3-33	A8A3A4C345	CM04FD101F03	81349	3-32	A8A3ALA2C317
CM04CD150J03	81349	3-32	A8A3A4A2C301	CM04ED390G03	81349	3-31	A8A3ALA1C305	CM04FD111F03	81349	3-32	A8A3A4A2C299
CM04CD150J03	81349	3-32	A8A3A4A2C303	CM04ED290G03	81349	3-31	A8A3A4A1C307	CM04FD111F03	81349	3-32	A8A3A4A2C301
CM04CD150J03	81349	3-32	A3AA3A4A2C315	CM04ED290G03	81349	3-31	A8A3A4A1C309	CM04FD111F03	81349	3-32	A8A3A4A2C303
CM04CD150J03	81349	3-32	A8A3A4A2C316	CM04ED390G03	81349	3-31	A8A3A4A1C311	CM04FD111F03	81349	3-32	A8A3A4A2C315
CM04CD150J03	81349	3-32	A8A3A4A2C317	CM04ED390003	81349	3-31	A8A3ALA1C3i3	CM04FD111F03	81349	3-32	A8A3A4A2C317
CM04CD150J03	81349		A8A6E2C13	CM04ED430G03	81349	3-31	A8A3A4A1C310	CM04FD111F03	81349	3-33	A8A3A4C337
CM04CD150J03	81349	3-52	A8A6E2C9	CM04ED430G03	81349	3-34	A8A3A4C328	CM04FD121F03	81349	3-32	A8A3A4A2C302
CM04CD150J03	81349	3-55	A8A7E2C200	CM04ED470G03	81349	3-34	A8A3A4C327	CM04FD121F03	81349	3-34	A8A3A4C323
CM04CD150J03	81349	3-55	A8A7E2C201	CM04ED510F03	81349	3-31	A8A3A4A1C305	CM04FD131F03	81349	3-32	A8A3A4A2C299
CM04ED200J03	81349	3-32	A8A3A4A2C299	CM04ED510F03	81349	3-31	A8A3A4A1C307	CM04FD131F03	81349	3-32	A8A3A4A2C301
CM04ED200J03	81349	3-32	A8A3A4A2C301	CM04ED510F03	81349	3-31	A8A3A4A1C309	CM04FD131F03	81349	3-32	A8A3A4A2C303
CM04ED200J03	81349	3-32	A8A3A4A2C303	CM04ED510F03	81349	3-31	A8A3A4A1C311	CM04FD131F03	81349	3-32	A8A3A4A2C315
CM04ED200J03	81349	3-32	A8A3A4A2C314	CM04ED510F03	81349	3-31	A8A3A4A1C313	CM04FD131F03	81349	3-32	A8A3A4A2C317
CM04ED200J03	81349	3-32	A8A3A4A2C315	CM04ED620F03	81349	3-31	A8A3A4A1C308	CM04FD151F03	81349	3-32	A8A3A4A2C299
CM04ED200J03	81349	3-32	A8A3A4A2C317	CM04ED620F03	81349	3-32	A8A3A4A2C299	CM04FD151F03	81349	3-32	A8A3A4A2C300
CM04ED220J03	81349	3-31	A8A3A4A1C305	CM04ED620F03	81349	3-32	A8A3A4A2C301	CM04FD151F03	81349	3-32	A8A3A4A2C301
CM04ED220J03	81349	3-31	A8A3A4A1C307	CM04ED620F03	81349	3-32	A8A3A4A2C303	CM04FD151F03	81349	3-32	A8A3A4A2C303
CM04ED220J03	81349	3-31	A8A3A4A1C309	CM04ED620F03	81349	3-32	A8A3A1A2C315	CM04FD151F03	81349	3-32	A8A3A4A2C315
CM04ED220J03	81349	3-31	A8A3A4A1C311	CM04ED620F03	81349	3-32	A8A3A4A2C317	CM04FD151F03	81349	3-32	A8A3A4A2C317
CM04ED220J03	81349	3-31	A8A3A4A1C313	CM04ED620F03	81349	3-34	A8A3A4C325	CM04FD151F03	81349	3-31	A8A3A4C322
CM04ED240J03	81349	3-32	A8A3A4A2C299	CM04ED620F03	81349	3-34	A8A3A4C326	CM04FD241F03	81349	3-31	A8A3A4C321
CM04ED240J03	81349	3-32	A8A3A4A2C301	CM04ED680F03	81349	3-34	A8A3ALC340	CM04FD910F03	81349	3-32	A8A3A4A2C299
CM04ED240J03	81349	3-32	A8A3A4A2C303	CM04ED820F03	81349	3-32	A8A3A4A2C299	CM04FD910F03	81349	3-32	A8A3A4A2C301
CM04ED240J03	81349	3-32	A8A3A4A2C315	CM04ED820F03	81349	3-32	A8A3A4A2C301	CM04FD910F03	81349	3-32	A8A3A4A2C303
CM04ED240J03	81349	3-32	A8A3A4A2C317	CM04ED820F03	81349	3-32	A8A3A4A2C303	CM04FD910F03	81349	3-32	A8A3A4A2C315
CM04ED270G03	81349	3-31	A8A3A4A1C305	CM04ED820F03	81349	3-32	A8A3A4A2C315	CM04FD910F03	81349	3-32	A8A3A4A2C317
CM04ED270G03	81349	3-31	A8A3A4A1C307	CM04ED82F003	81349	3-32	A8A3A4A2C317	CM05CD050D03	81349	3-37	A8A3E46C280
CM04ED270G03	81349	3-31	A8A3A4A1C309	CM04ED820F03	81349	3-34	P8A3A4C324	CM05CD050D03	81349		A8A6C14
CM04ED270G03	81349	3-31	A8A3A4A1C311	CM04FA331F03	81349	3-31	A8A3A4C3L9	CM05CD050D03	81349		A8A6C20
CM04ED270G03	81349	3-31	A8A3A4A1C313	CM04FA361F03	81349	3-32	A8A3A4A2C298	CM05CD050D03	81349		A8A6C23
CM04ED270G03	81349	3-32	A8A3A4A2C299	CM04FA361F03	81349	3-34	A8A3A4C320	CM05CD050D03	81349		A8A6C29
CM04ED270GC3	81349	3-32	A8A3A4A2C301	CM04FD101F03	81349	3-31	A8A3AA11C304	CM05CD050D03	81349		A8A6C3L
CM04ED270G03	81349	3-32	A8A3A4A2C303	CM04FD101F03	81349	3-31	A8A3A4A1C306	CM05CD050D03	81349	3-59	A8A7E6C100

**SECTION IV. INDEX-FEDERAL STOCK NUMBER & REFERENCE NUMBER CROSS-REFERENCE
TO FIGURE & ITEM NUMBER (Continued)**

FEDERAL STOCK NUMBER	FIGURE NUMBER		ITEM NUMBER OR REF. DESIGNATION	FEDERAL STOCK NUMBER	FIGURE NUMBER		ITEM NUMBER OR REF. DESIGNATION	FEDERAL STOCK NUMBER	FIGURE NUMBER		ITEM NUMBER OR REF. DESIGNATION
	MFG CO.	FIG NO.			MFG CO.	FIG NO.			MFG CO.	FIG NO.	
REF NO.	MFG CO.	FIG NO.	ITEM NO OR REF DES.	REF NO.	MFG CO.	FIG NO.	ITEM NO OR REF DES.	REF NO.	MFG CO.	FIG NO.	ITEM NO OR REF DES.
CM05CD050D03	81349	3-59	A8A7E6C101	CM05ED220J03	81349	3-57	A8A7E4C68	CM05ED300G03	81349	3-60	A8A7E7A1C138
CM05CD100D03	81349	3-38	A8A3E47C165	CM05ED220J03	81349	3-57	A8A7E4C70	CM05ED300G03	81349	3-60	A8A7E7A1C110
CM05CD110D03	81349		A8A6C14	CM05ED240J03	81349		A8A6C11	CM05ED300G03	81349	3-60	A8A7E7A1C142
CM05CD100D03	81349		A8A6200	CM05ED240J03	81349		A8A6C20	CM05ED300G03	81349	3-60	A8A7E7A1C144
CM05CD100D03	81349		A8A6C23	CM05ED240J03	81349		A8A6C23	CM05ED300G0 3	81349	3-60	A8A7E7A1C146
CM05CD100D03	81349		A8A6C29	CM05ED240J03	81349		A8A6C29	CM05ED300G03	81349	3-60	A8A7E7A1C148
CM05CD01D03	81349		A8A6C34	CM05ED240J03	81349		A8A6C34	CM05ED300C03	81349	3-60	A8A7E7A1C150
CM05CD100D3	81349	3-57	A8A7E4C56	CM05ED270G03	81349	3-29	A8A3A10C81	CM05ED300G03	81349	3-60	A8A7E7A1C152
CM05CD100D3	81349	3-58	A8A7E5C71	CM05ED270G03	81349	3-30	A8A3A11C104	CM05ED300J03	81349	3-20	A8A2E1C36
CM05CD120J03	81349		A8A6C14	CM05ED270G03	81349	3-30	A8A3A11C110	CM05ED300J03	81349		A8A6C14
CM05CD120J03	81349		A8A6C20	CM05ED270G03	81349	3-26	A8A3A9A1C9	CM05ED300J03	81349		A8A6C20
CM05CD120J03	81349		A8A6C23	CM05ED270G03	81349	3-28	A8A3A9A3C56	CM05ED300J03	81349		A8A6C23
CM05CD120J03	81349		A8A6C29	CM05ED270G03	81349	3-23	A8A3TB2C187	CM05ED300J03	81349		A8A6C29
CM05CD120J03	81349		A8A6C34	CM05ED270J03	81349	3-20	A8A2E1C36	CM05ED300J03	81349		A8A6C34
CM05CD180J03	81349	3-20	A8A2E1C36	CM05ED270J03	81349	3-20	A8A2E1C9	CM05ED330G03	81349	3-29	A8A3A10C77
CM05CD180J03	81349		A8A6C14	CM05ED270J03	81349	3-36	A8A3A13C261	CM05ED330G03	81349	3-29	A8A3A10C83
CM05CD180J03	81349		A8A6C20	CM05ED270J03	81349		A8A6C14	CM05ED330G03	81349	3-26	A8A3A9A1C7
CM05CD180J03	81349		A8A6C23	CM05ED270J03	81349		A8A6C20	CM05ED330G03	81349	3-28	A8A3A9A3C54
CM05CD180J03	81349		A8A6C29	CM05ED270J03	81349		A8A6C23	CM05ED330G03	81349	3-60	A8A7E7A1C114
CM05CD180J03	81349		A8A6C31	CM05ED270J03	81349		A8A6C29	CM05ED330G03	81349	3-60	A8A7E7A1C116
CM05CD180J03	81349	3-54	A8A7E1C12	CM05ED270J03	81349		A8A6C34	CM05ED330G03	81349	3-60	A8A7E7A1C118
CM05CD180J03	81349	3-54	A8A7E1C16	CM05ED270J03	81349	3-51	A8A7E1C3	CM05ED330G03	81349	3-60	A8A7E7A1C120
CM05ED200J03	81349	3-36	A8A3A13C263	CM05ED300G03	81349	3-26	A8A3A9A1C8	CM05ED330G03	81349	3-60	A8A7E7A1C122
CM05ED200J03	81349	3-26	A8A3A9A1C10	CM05ED300G03	81349	3-24	A8A3A9A2C22	CM05ED330G03	81349	3-60	A8A7E7A1C124
CM05ED200J03	81349	3-38	A8A3E47C180	CM05ED300G03	81349	3-24	A8A3A9A2C24	CM05ED330G03	81349	3-60	A8A7E7A1C126
CM05ED200J03	81349		A8A6C14	CM05ED300G03	81349	3-24	A8A3A9A2C26	CM05ED330G03	81349	3-60	A8A7E7A1C128
CM05ED200J03	81349		A8A6C20	CM05ED300G03	81349	3-60	A8A7E7A1C114	CM05ED330G03	81349	3-60	A8A7E7A1C130
CM05ED200J03	81349		A8A6C23	CM05ED300G03	81349	3-60	A8A7E7A1C116	CM05ED330G03	81349	3-60	A8A7E7A1C132
CM05ED200J03	81349		A8A6C29	CM05ED300G03	81349	3-60	A8A7E7A1C118	CM05ED330G03	81349	3-60	A8A7E7A1C134
CM05ED200J03	81349		A8A6C34	CM05ED300G03	81349	3-60	A8A7E7A1C120	CM05ED330G03	81349	3-60	A8A7E7A1C136
CM05ED200J03	81349	3-54	A8A7E1C2	CM05ED300G03	81349	3-60	A8A7E7A1C122	CM05ED330G03	81349	3-60	A8A7E7A1C138
CM05ED220J03	81349	3-20	A8A2E1C36	CM05ED300G03	81349	3-60	A8A7E7A1C124	CM05ED330G03	81349	3-60	A8A7E7A1C140
CM05ED220J03	81349		A8A6C14	CM05ED300G03	81349	3-60	A8A7E7A1C126	CM05ED330G03	81349	3-60	A8A7E7A1C142
CM05ED220J03	81349		A8A6C20	CM05ED300G03	81349	3-60	A8A7E7A1C128	CM05ED330G03	81349	3-60	A8A7E7A1C144
CM05ED220J03	81349		A8A6C23	CM05ED300G03	81349	3-60	A8A7E7A1C130	CM05ED330G03	81349	3-60	A8A7E7A1C146
CM05ED220J03	81349		A8A6C29	CM05ED300G03	81349	3-60	A8A7E7A1C132	CM05ED330G03	81349	3-60	A8A7E7A1C148
CM05ED220J033	81349		A8A6C34	CM05ED300G03	81349	3-60	A8A7E7A1C134	CM05ED330G03	81349	3-60	A8A7E7A1C150
CM05ED220J03	81349	3-57	A8A7E4C66	CM05ED300G03	81349	3-60	A8A7E7A1C136	CM05ED330G03	81349	3-60	A8A7E7A1C152

**SECTION IV. INDEX-FEDERAL STOCK NUMBER & REFERENCE NUMBER CROSS-REFERENCE
TO FIGURE & ITEM NUMBER (Continued)**

FEDERAL STOCK NUMBER	FIGURE NUMBER		ITEM NUMBER OR REF. DESIGNATION	FEDERAL STOCK NUMBER	FIGURE NUMBER		ITEM NUMBER OR REF. DESIGNATION	FEDERAL STOCK NUMBER	FIGURE NUMBER		ITEM NUMBER OR REF. DESIGNATION
	MFG CO.	FIG NO.			MFG CO.	FIG NO.			MFG CO.	FIG NO.	
REF NO.	MFG CO.	FIG NO.	ITEM NO OR REF DES.	REF NO.	MFG CO.	FIG NO.	ITEM NO OR REF DES.	REF NO.	MFG CO.	FIG NO.	ITEM NO OR REF DES.
CM05ED330J03	81349	3-20	A8A2E136	CM05ED390G03	81349	3-60	A8A7E7A1C118	CM05ED430G03	81349	3-60	A8A7E7A1C128
CM05ED330J03	81349		A8A6C14	CM05ED390G03	81349	3-60	A8A7E7A1C120	CM05ED430G03	81349	3-60	A8A7E7A1C130
CM05ED330J03	81349		A8A6C20	CM05ED390G03	81349	3-60	A8A7E7AC122	CM05ED430G03	81349	3-60	A8A7E7A1C132
CM05ED330J03	81349		A8A6C23	CM05ED390G03	81349	3-60	A8A7E7A1C124	CM05ED430G03	81349	3-60	A8A7E7A1C134
CM05ED330J03	81349		A8A6C29	CM05ED390G03	81349	3-60	A8A7E7A1C126	CM05ED430G03	81349	3-60	A8A7E7A1C136
CM05ED330J03	81349		A8A6C34	CM05ED290G03	81349	3-60	A8A7E7A1C128	CM05ED430G03	81349	3-60	A8A7E7A1C138
CM05ED360G03	81349	3-26	A8A3A9A1C6	CM05ED390G03	81349	3-60	A8A7E7A11C130	CM05ED430G03	81349	3-60	A8A7E7A1C140
CM05ED360G03	81349	3-60	A8A7E7A1C114	CM05ED390G03	81349	3-60	A8A7E7A1C132	CM05ED430G03	81349	3-60	A8A7E7A1C142
CM05ED360G03	81349	3-60	A8A7E7A1C116	CM05ED390G03	81349	340	A8A7E7A1C134	CM05ED430G03	81349	3-60	A8A7E7A1C144
CM05ED360G03	81349	3-60	A8A7E7A1C18	CM05ED390G03	81349	3-60	A8A7E7A1C136	CM05ED430G03	81349	3-60	A8A7E7A1C146
CM05ED360G03	81349	3-60	A8A7E7A1C120	CM05ED390G03	81349	3-60	A8A7E7A1C138	CM05ED430G03	81349	3-60	A8A7E7A1C148
CM05ED360G03	81349	3-60	A8A7E7A1C122	CM05ED390G03	81349	3-60	A8A7E7A1C10	CM05ED430G03	81349	3-60	A8A7E7A1C150
CM05ED360G03	81349	3-60	A8A7E7A1 C124	CM05ED390G03	81349	3-60	A8A7E7A1C142	CM05ED430G03	81349	3-60	A8A7E7A1C152
CM05ED360G03	81349	3-60	A8A7E7A1C126	CM05ED390G03	81349	3-60	A8A7E7A1C144	CM05ED430J03	81349		A8A6C14
CM05ED360G03	81349	3-60	A8A7E7A1C128	CM05ED390G03	81349	3-60	A8A7E7A1C146	CM05ED430J03	81349		A8A6C20
CM05ED360G03	81349	3-60	A8A7E7A1C130	CM05KD390G03	81349	3-60	A8A7E7A1C148	CM05ED430J03	81349		A8A6C23
CM05ED360G03	81349	3-60	A8A7E7AC132	CM05ED390G03	81349	3-60	A8A7E7A1C150	CM05ED430J03	81349		A8A6C29
CM05ED360G03	81349	3-60	A8A7E7A1C134	CM05ED390G03	81349	3-60	A8A7E7A1C152	CM05ED430J03	81349		A8A6C34
CM05ED360G03	81349	3-60	A8A7E7A1C136	CM05ED390J03	81349		A8A6414	CM05ED470J03	81349		A8A6C14
CM05ED360G03	81349	3-60	A8A7E7A1C138	CM05ED390J03	81349		A8A6C20	CM05ED470J03	81349		A8A6C20
CM05ED360G03	81349	3-60	A8A7E7A1C140	CM05ED390J03	81349		A8A6C23	CM05ED470J03	81349		A8A6C23
CM05ED360G03	81349	3-60	A8A7E7A1C142	CM05ED390J03	81349		A8A6C29	CM05ED470J03	81349		A8A6C29
CM05ED360G03	81349	3-60	A8A7E7A1144	CM05ED390J03	81349		A8A6C34	CM05ED470J03	81349		A8A6C34
CM05ED360G03	81349	3-60	A8A7E7A1C146	CM05ED390J03	81349	3-57	A8A7E4C65	CM05ED510G03	81349	3-30	A8A3A11C111
CM05ED360G03	81349	3-60	A8A7E7A1C148	CM05ED390J03	81349	3-57	A8A7E4C67	CM05ED510G03	81349	3-26	A8A3A9A1C4
CM05ED360G03	81349	3-60	A8A7E7A1C150	CM05ED390J03	81349	3-57	A8A7E4C69	CM05ED510J03	81349		A8A6C14
CM05ED360G03	81349	3-60	A8A7E7A1C152	CM05ED390J03	81349	3-59	A8A7E6C104	CM05ED510J03	81349		A8A6C20
CM05ED360J03	81349	3-20	A8A2E1C36	CM05ED390J03	81349	3-59	A8A7E6C106	CM05ED510J03	81349		A8A6C23
CM05ED360J03	81349		A8A6C14	CM05ED390J03	81349	3-59	A8A7E6C108	CM05ED510J03	81349		A8A6C29
CM05ED360J03	81349		A8A6C20	CM05ED430G03	81349	3-30	A8A3A11C108	CM05ED510J03	81349		A8A6C34
CM05ED360J03	81349		A8A6C23	CM05ED430G03	81349	3-26	A8A3A9A1C5	CM05ED560G03	81349	3-30	A8A3A11C98
CM05ED360J03	81349		A8A6C29	CM05ED430G03	81349	3-60	A8A7E7A1C114	CM05ED560G03	81349	3-35	A8A3A12C137
CM58ED360J03	81349		A8A6C34	CM05ED430G03	81349	3-60	A8A7E7A1C116	CM05ED560G03	81349	3-25	A8A3A9A2C27
CM05ED360J03	81349	3-58	A8A7E5C91	CM05ED830G03	81349	3-60	A8A7E7A1C118	CM05ED560G03	81349	3-28	A8A3A9A3C44
CM05ED390G03	81349	3-29	A8A3A10C79	CM05ED830G03	81349	3-60	A8A7E7A1C120	CM05ED560J03	81349		A8A6C14
CM05ED390G03	81349	3-36	A8A3A13C259	CM05ED830G03	81349	3-60	A8A7E7A1C122	CM05ED560J03	81349		A8A6C20
CM05ED390G03	81349	3-60	A8A7E7A1C114	CM05ED830G03	81349	3-60	A8A7E7A1C124	CM05ED560J03	81349		A8A6C23
CM05ED390G03	81349	3-60	A8A7E7A1C116	CM05ED830G03	81349	3-60	A8A7E7A1C126	CM05ED560J03	81349		A8A6C29

**SECTION IV. INDEX-FEDERAL STOCK NUMBER & REFERENCE NUMBER CROSS-REFERENCE
TO FIGURE & ITEM NUMBER (Continued)**

FEDERAL STOCK NUMBER	FIGURE NUMBER		ITEM NUMBER OR REF. DESIGNATION	FEDERAL STOCK NUMBER	FIGURE NUMBER		ITEM NUMBER OR REF. DESIGNATION	FEDERAL STOCK NUMBER	FIGURE NUMBER		ITEM NUMBER OR REF. DESIGNATION
	MFG CO.	FIG NO.			MFG CO.	FIG NO.			MFG CO.	FIG NO.	
REF NO.	MFG CO.	FIG NO.	ITEM NO OR REF DES.	REF NO.	MFG CO.	FIG NO.	ITEM NO OR REF DES.	REF NO.	MFG CO.	FIG NO.	ITEM NO OR REF DES.
CM05ED560J03	81349		A8A6C34	CM05ED820G03	81349	3-29	A83A100C86	CM05FD131J03	81349		A8A6C14
CM05ED560J03	81349	3-58	A8A7E5C89	CM05ED820G03	81349	3-25	A8A3A9A2C29	CM05FD131J03	81349		A8A6C20
CM05ED620G03	81349	3-30	A8A3A11C100	CM05ED820G03	81349	3-28	A8A3A9A3C59	CM05FD131J03	81349		A8A6C23
CM05ED620G03	81349	3-30	A8A3A11C106	CM05ED820J03	81349	3-39	A8A3E48C162	CM05FD131J03	81349		A8A6C29
CM05ED620G03	81349	3-30	A8A3A11C113	CM05ED820J03	81349	3-39	A8A3E48C174	CM05FD131J03	81349		A8A6C34
CM05ED620G03	81349	3-36	A8A3A13C257	CM05ED820J03	81349		A8A6C14	CM05FD13L103	81349	3-58	A8A7E5C81
CM05ED620G03	81349	3-28	A8A3A9A3C48	CM05ED820J03	81349		A8A6C20	CM05FD151G03	81349	3-26	A8A3A9A1C1
CM05ED620J03	81349		A8A6C14	CM05ED820J03	81349		A8A6C23	CM05FD151G03	81349	3-39	A8A3E48C168
CM05ED620J03	81349		A8A6C20	CM05ED820J03	81349		A8A6C29	CM05FD151J03	81349		A8A6C14
CM05ED620J03	81349		A8A6C23	CM05ED820J03	81349		A8A6C34	CM05FD153J03	81349		A8A6C20
CM05ED620J03	81349		A8A6C29	CM05ED820J03	81349	3-58	A8A7E5C85	CM05FD151J03	81349		A8A6C23
CM05ED620J03	81349		A8A6C34	CM05FD101G03	81349	3-21	A8A2E3C14	CM05FD151J03	81349		A8A6C29
CM05ED680C03	81349	3-26	A8A3A9A1C3	CM05FD101G03	81349	3-26	A8A3A9A1C2	CM05FD151J03	81349		A8A6C34
CM05ED680G03	81349	3-28	A8A3A9A3C50	CM05FD101J03	81349	3-37	A8AA346C246	CM05FD151J03	81349	3-55	A8A7E2C28
CM05ED680G03	81349	3-28	A8A3A9A3C52	CM05FD101J03	81349	3-37	A8A3E46C268	CM05FD151J03	81349	3-55	A8A7E2C34
CM05ED680G03	81349	3-28	A8A3A9A3C57	CM05FD101J03	81349	3-37	A8A3E46C271	CM05FD1610G3	81349	3-39	A8A3E148C168
CM05ED680J03	81349	3-66	A8A4A1C140	CM05FD101J03	81349	3-53	A8A6A1C17	CM051D161G03	81349	3-58	A8A7E5C79
CM05ED680J03	81349		A8A6C14	CM05FD101J03	81349	3-53	A8BA6A1C19	CM05FD161J03	81349		A8A6C14
CM05ED680J03	81349		A8A6C20	CM05FD101J03	81349		A8A6C14	CM05FD161J03	81349		A8A6C20
CM05ED680J03	81349		A8A6C23	CM05FD101J03	81349		A8A6C20	CM05FD161J03	81349		A8A6C23
CM05ED680J03	81349		A8A6C29	CM05FD101J03	81349		A8A6C23	CM05FD161J03	81349		A8A6C29
CM05ED680J03	81349		A8A6C34	CM05FD101J03	81349		A8A6C29	CM05FD163J03	81349		A8A6C34
CM05ED680J03	81349	3-58	A8A7E5C87	CM05FD101J03	81349		A8A6C34	CM05FD181G03	81349	3-29	A8A3A10C71
CM05ED680J03	81349	3-56	A8A7TB1C169	CM05FD101J03	81349	3-52	A8A6E2C6	CM05FD181G03	81349	3-59	A8A7E6C97
CM05ED680J03	81349	3-56	A8A7TB1C170	CM05FD101J03	81349	3-52	A8A6E2C7	CM05FD181G03	81349	3-59	A8A7E6C99
CM05ED680J03	81349	3-56	A8A7TB1C172	CM05FD111J03	81349		A8A6C14	CM05FD181J03	81349	3-37	A8A3E46C270
CM05ED680J03	81349	3-56	A8A7TB1C174	CM05FD111J03	81349		A8A6C20	CM05FD181J03	81349	3-37	A8A3E46C273
CM05ED750G03	81349	3-29	A8A3A10C75	CM05FD111J03	81349		A8A6C23	CM05FD181J03	81349		A8A6C14
CM05ED750G03	81349	3-35	A8A3A12C135	CM05FD111J03	81349		A8A6C29	CM05FD181J03	81349		A8A6C20
CM05ED750G03	81349	3-35	A8A3A12C140	CM05FD111J03	81349		A8A6C34	CM05FD181J03	81349		A8A6C23
CM05ED750G03	81349	3-28	A8A3A9A3C46	CM05FD111J03	81349	3-58	A8A7E5C83	CM05FD181J03	81349		A8A6C29
CM05ED750G03	81349	3-39	A8A3E48C169	CM05FD121G03	81349	3-39	A8A3E48C168	CM05FD181J03	81349		A8A6C34
CM05ED750G03	81349	3-39	A8A3E48C184	CM05FD121J03	81349		A8A6C14	CM05FD181J03	81349	3-54	A8A7E1C157
CM05ED750J03	81349		A8A6C14	CM05FD121J03	81349		A8A6C20	CM05FD201G03	81349	3-58	A8A7E5C77
CM05ED750J03	81349		A8A6C20	CM05FD121J03	81349		A8A6C23	CM05FD201G03	81349	3-56	A8A7TB1C171
CM05ED750J03	81349		A8A6C23	CM05FD121J03	81349		A8A6C29	CM05FD201G03	81349	3-56	A8A7TB1C1T3
CM05ED750J03	81349		A8A6C29	CM05FD121J03	81349		A8A6C34	CM05FD201G03	81349	3-56	A8A7TB1C175
CM05ED750J03	81349		A8A6C34	CM05FD131G03	81349	3-39	A8A3E48C168	CM05FD201G03	81349		A8A6C14

**SECTION IV. INDEX-FEDERAL STOCK NUMBER & REFERENCE NUMBER CROSS-REFERENCE
TO FIGURE & ITEM NUMBER (Continued)**

FEDERAL STOCK NUMBER	FIGURE NUMBER		ITEM NUMBER OR REF. DESIGNATION	FEDERAL STOCK NUMBER	FIGURE NUMBER		ITEM NUMBER OR REF. DESIGNATION	FEDERAL STOCK NUMBER	FIGURE NUMBER		ITEM NUMBER OR REF. DESIGNATION
	MFG CO.	FIG NO.			MFG CO.	FIG NO.			MFG CO.	FIG NO.	
REF NO.			ITEM NO OR REF DES.	REF NO.			ITEM NO OR REF DES.	REF NO.			ITEM NO OR REF DES.
CM05FD201J03	81349		A8A6C20	CM05FD271J03	81349	3-55	A8A7E2C33	CM06FD272F03	81349	3-52	A8A6E1C33
CM05FD201J03	81349		A8A6C23	CM05FD301J03	81349		A8A6C14	CM06FD302F03	81349	3-17	A8A1E1C19
CM05FD201J03	81349		A8A6C29	CM05FD301J03	81349		A8A6C20	CM06FD751J03	81349		A8A6C14
CM05FD201J03	81349		A8A6C34	CM05FD301J03	81349		A8A6C23	CM06FD751J03	81349		A8A6C20
CM05FD221G03	81349	3-39	A8A3E48C167	CM05FD301J03	81349		A8A6C29	CM06FD751J03	81349		A8A6C23
CM05FD221G03	81349	3-39	A8A3E48C170	CM05FD301J03	81349		A8A6C34	CM06FD751J03	81349		A8A6C29
CM05FD221G03	81349	3-39	A8A3E48C172	CM05FD331J03	81349		A8A6C14	CM06FD751J03	81349		A8A6C34
CM05FD221G03	81349	3-56	A8A7TB1C167	CM05FD331J03	81349		A8A6C20	CM60B622J01	81349	3-64	A5A4C122
CM05FD221G03	81349	3-56	A8A7TB1C176	CM05FD331J03	81349		A8A6C23	CR14M2277	99155		A8A4109W1
CM05FD221J03	81349	3-20	A88A2E1C7	CM05FD331J03	81349		A8A6C29	CR14M2277	99155		A8A4110W1
CM05FD221J03	81349	3-20	A8A2E1C8	CM05FD331J03	81349		A8A6C34	CR14M2277	99155		A8A4111W1
CM05FD221J03	81349	3-21	A8A2E4C22	CM05FD361G03	81349	3-58	A8A7E5C73	CR14M2277	99155		A8A4112W1
CM05FD221J03	81349	3-21	A8A2E5C27	CM05FD361J03	81349		A88A6C1	CV1377APRC47	80058	3-4	A8A3
CM05FD221J03	81349	3-21	A8A2E5C32	CM05FD361J03	81349		A8A6C20	CX8393PRC47	80058	1-7	W1
CM05FD221J03	81349	3-53	A8A6A1C40	CM05FD361J03	81349		A8A6C23	CX8394PRC47	80958	1-7	W2
CM05FD221J03	81349		A8A6C14	CM05FD361J03	81349		A8A6C29	CX8395PRC47	80058	1-1	W3
CM05FD221J03	81349		A8A6C20	CM05FD361J03	81349		A8A6C34	CY3700PRC47	80058	1-4	A1
CM05FD221J03	81349		A8A6C23	CM05FD391G03	81349	3-21	A8A2E3C11	C023B102P223Z	56289	3-40	A8A3C117
CM05FD221J03	81349		A8A6C29	CM05FD391G03	81349	3-21	A8A2E5C24	C023B102P223Z	56289	3-40	A8A3C292
CM05FD221J03	81349		A8A6C34	CM05FD391G03	81349	3-35	A8A3A12C122	C3044-1-35	78553		A8A4MP20
CM05FD221J03	81349	3-54	A8A7E1C14	CM05FD391J03	81349	3-38	A8A3E47C148	C4311PRC47	80058	3-4	A8A7
CM05FD221J03	81349	3-59	A8A7E6C105	CM05FD391J03	81349		A8A6C14	C4344-4-75	82647	3-65	A8A4K103
CM05FD221J03	81349	3-59	A8A7E6C107	CM05FD391J03	81349		A8A6C20	DAMF3W3S	71785	3-67	A8A4J10
CM05FD221J03	81349	3-59	A8A7E6C109	CM05FD391J03	81349		A8A6C23	DAMF7W2S	71785	3-67	A8A4J11
CM05FD221J03	81349	3-21	A8A2E5C12	CM55FD391J03	81349		A8A6C29	DAMF7W2S	71785	3-67	A8A4J3
CM05FD241J03	81349		A8A6C14	CM05FD391J03	81349		A8A6C34	DAMF7W2S	71785		A8A4J5
CM05FD241J03	81349		A8A6C20	CM05FD910G03	81349	3-21	A8A2E4C16	DAMF7W2S	71785		A8A4J6
CM05FD241J03	81349		A8A6C23	CM05FD910G03	81349	3-30	A8A3A11C102	DAMF7W2S	71785	3-67	A8A4J7
CM05FD241J03	81349		A8A6C29	CM05FD910G03	81349	3-35	A8A3A12C129	DAMF7W2S	71785	3-67	A8A4J8
CM05FD241J03	81349		A8A6C34	CM05FD910G03	81349	3-35	A8A3A12C138	DAM3W3P	71468		A8A7P2
CM05FD241J03	81349	3-59	A8A7E6C103	CM05FD910G03	81349	3-36	A8A3A13C255	DAM7W2P	71468	3-20	A8A2P3
CM05FD271G03	81349	3-58	A8A7E5C75	CM05FD910J03	81349		A8A6C14	DAM7W2P	71468	3-41	A8A3P1
CM05FD271J03	81349		A8A6C14	CM05FD310J03	81349		A8A6C20	DAM7W2P	71468	3-41	A8A3P2
CM05FD271J03	81349		A8A6C20	CM05FD910J03	81349		A8A6C23	DAM7W2P	71468	3-L1	A8A3P3
CM05FD271J03	81349		A8A6C23	CM05FD910J03	81349		A8A6C29	DAM7W2P	71468	3-41	A8A3P4
CM05FD271J03	81349		A8A6C29	CM05FD910J03	81349		A8A6C34	DAM7W2P	71468	3-61	A8A7P1
CM05FD271J03	81349		A8A6C34	CM06FD162J03	81349	3-53	A8A6A1C24	DA146	71590	3-41	A8A3C188
CM05FD271J03	81349	3-55	A8A7E2C27	CM06FD242J03	81349	3-52	A8A6E1C28	DA146	71590	3-41	A8A3C289

**SECTION IV. INDEX-FEDERAL STOCK NUMBER & REFERENCE NUMBER CROSS-REFERENCE
TO FIGURE & ITEM NUMBER (Continued)**

FEDERAL STOCK NUMBER	FIGURE NUMBER		ITEM NUMBER OR REF. DESIGNATION	FEDERAL STOCK NUMBER	FIGURE NUMBER		ITEM NUMBER OR REF. DESIGNATION	FEDERAL STOCK NUMBER	FIGURE NUMBER		ITEM NUMBER OR REF. DESIGNATION
	MFG CO.	FIG NO.			MFG CO.	FIG NO.			MFG CO.	FIG NO.	
REF NO.	MFG CO.	FIG NO.	ITEM NO OR REF DES.	REF NO.	MFG CO.	FIG NO.	ITEM NO OR REF DES.	REF NO.	MFG CO.	FIG NO.	ITEM NO OR REF DES.
DA146	71590	3-41	A8A3C290	DM10C047D03	72136		A8A6E2C13	DM15E111F0300WVCR	72136	3-25	A8A3A9A2C16
DA146	71590	3-41	A8A3C291	DM10C047D03	72136	3-52	A8A6E2C9	DM15E111F0300WVCR	72136	3-28	A8A3A9A3C53
DA146	71590	3-23	A8A3TB2C89	DM10C056D03	72136		A8A6E2C13	DM15E111F0300WVCR	72136	3-28	A8A3A9A3C55
DA146	71590	3-23	A8A3TB2C90	DM10C056D03	72136	3-52	A8A6E2C9	DM15E111F0300WVCR	72136	3-39	A8A3E4SC168
DA146	71590		A8A4C28	DM10C066D03	72136		A8A6E2C13	DM15E121F0300WVCR	72136	3-29	A8A3A100C73
DA858-003	71590	3-64	A8A4C123	DM10C066D03	72136	3-52	A8A6E2C9	DM15E121F0300WVCR	72136	3-29	A8A3A1CC82
DBMF13W3S	71468	3-67	A8A4J4	DM10C068D03	72136		A8A6E2C13	DM15E121F0300WVCR	72136	3-24	A8A3A9A2C20
DBMF13W3S	71468	3-67	A8A4J9	DM10C068D03	72136	3-52	A8A6E2C9	DM15E121F0300WVCR	72136	3-24	A8A3A9A2C23
DBMF23S	71468	3-67	A8A4J2	DM10C075D03	72136		A8A6E2C13	DM15E121F0300WVCR	72136	3-24	A8A3A9A2C25
DBM13W3P	71468	3-21	A8A2P4	DM10C075D03	72136	3-52	A8A6E2C9	DM15E127F0300WVCR	72136	3-39	A8A3E48C168
DBM13W3P	71468	3-52	A8A6P1	DM10C082D03	72136		A8A6E2C13	DM15E133F0300WVCR	72136	3-35	A8A3A12C130
DBM25P	71468	3-16	A8A1P1	DM10C082D03	72136	3-52	A8A6E2C9	DM15E133F0300WVCR	72136	3-36	A8A3A13C253
DCMF27W2S	71468	3-67	A8A4J1	DM10C091D03	72136		A8A6E2C13	DM15E133F0300WVCR	72136	3-28	A8A3A9A3C49
DC027W2P	71468	3-45	A8A5P1	DM10C091D03	72136	3-52	A8A6E2C9	DM15E133F0300WVCR	72136	3-39	A8A3E48C168
DD16-103	71590	3-47	A8A5E1C15	DM15C100K500WVRCR	72136	3-36	A8A3A13C265	DM15E141F0300WVCR	72136	3-29	A8A3A10C80
DM10C020D0	14655	3-31	A8A3A4A1C305	DM15C100K500WVRCR	72136	3-36	A8A3A13C267	DM15E141F0300WVCR	72136	3-39	A8A3E48C168
DM10C020D0	14655	3-31	A8A3A4A1C307	DM150150J500VDC	72136	3-20	A8A2E1C36	DM15E141F0300WVCR	72136		A8A6C14
DM10C020D0	14655	3-31	A8A3A4A1C309	DM150150J500VDC	72136		A8A6C14	DM15E141F0300WVCR	72136		A8A6C20
DM10C020D0	14655	3-31	A8A3A4A1C311	DM150150J500VDC	72136		A8A6C20	DM15E141F0300WVCR	72136		A8A6C23
DM10C020D0	14655	3-31	A8A3A4A1C313	DM150150J500VDC	72136		A8A6C23	DM15E141F0300WVCR	72136		A8A6C29
DM10C020D0	14655		A8A6E2C13	DM150150J500VDC	72136		A8A6C29	DM15E141F0300WVCR	72136		A8A6C34
DM10C020D0	14655	3-52	A8A6E2C9	DM15E101F0300WVCR			A8A6C34	DM15E151F0300WVCR	72136	3-35	A8A3A12C127
DM10C022D03	72136		A8A6E2C13	DM15E101F0300WVCR	72136	3-30	A8A3A11C105	DM15E151F0300WVCR	72136	3-24	A8A3A9A2C17
DM10C022D03	72136	3-52	A8A6E2C9	DM15E101F0300WVCR	72136	3-30	A8A3A11C107	DM15E151F0300WVCR	72136	3-24	A8A3A9A2C21
DM10C024D03	72136		A8A6E2C13	DM15E101F0300WVCR	72136	3-35	A8A3A12C132	DM15E165F0300WVCR	72136	3-29	A8A3A10C78
DM10C024D03	72136	3-52	A8A6E2C9	DM15E101F0300WVCR	72136	3-35	A8A3A12C133	DM15E165F0300WVCR	72136	3-30	A8A3A11C101
DM10C027D03	72136		A8A6E2C13	DM15E101F0300WVCR	72136	3-35	A8A3A12C134	DM15E165F0300WVCR	72136	3-30	A8A3A11C103
DM1C027D03	72136	3-52	A8A6E2C9	DM15E101F0300WVCR	72136	3-35	A8A3A12C136	DM15E165F0300WVCR	72136	3-35	A8A3A12C125
DM10C030D0	14655		A8A6E2C13	DM15E101F0300WVCR	72136	3-24	A8A3A9A2C18	DM15E165F0300WVCR	72136	3-36	A8A3A13C251
DM10C030D0	14655	3-52	A8A6E2C9	DM15E101F0300WVCR	72136	3-24	A8A3A9A2C19	DM15E165F0300WVCR	72136	3-25	A8A3A9A2C14
DM10C033D03	72136		A8A6E2C13	DM15E101F0300WVCR	72136	3-28	A8A3A9A3C51	DM15E169F0300WVCR	72136		A8A6C14
DM10C033D03	72136	3-52	A8A6E2C9	DM15E101J0100WVCR	72136	3-52	A8A6E1C27	DM15E169F0300WVCR	72136		A8A6C20
DM10C036D03	72136		A8A6E2C13	DM15E101J0100WVCR	72136	3-52	A8A6E2C10	DM15E169F0300WVCR	72136		A8A6C23
DM10C036D03	72136	3-52	A8A6E2C9	DM15E102J0100WVCR	72136	3-52	A8A6E2C3	DM15E169F0300WVCR	72136		A8A6C29
DM10C039D03	72136		A8A6E2C13	DM15E102J0100WVCR	72136	3-52	A8A6E2C5	DM15E169F0300WVCR	72136		A8A6C34
DM10C039D03	72136	3-52	A8A6E2C9	Dm5E102J0100Wv4CR	72136	3-52	A8A6E2C8	DM15E169F0300WVCR	72136	3-28	A8A3A9A3C47
DM10C043D03	72136		A8A6E2C13	DM15E111F0300WVCR	72136	3-29	A8A3A10C84	DM15E169F0300WVCR	72136		A8A6C14
DM10C303D03	72136	3-52	A8A6E2C9	DM15E111F0300WVCR	72136	3-35	A8A3A12C131	DM15E169F0300WVCR	72136		A8A6C20
DM10C43D03	72136		A8A6E2C13								
DM10C043D03	72136	3-52	A8A6E2C9								

**SECTION IV. INDEX-FEDERAL STOCK NUMBER & REFERENCE NUMBER CROSS-REFERENCE
TO FIGURE & ITEM NUMBER (Continued)**

FEDERAL STOCK NUMBER	FIGURE NUMBER		ITEM NUMBER OR REF. DESIGNATION	FEDERAL STOCK NUMBER	FIGURE NUMBER		ITEM NUMBER OR REF. DESIGNATION	FEDERAL STOCK NUMBER	FIGURE NUMBER		ITEM NUMBER OR REF. DESIGNATION
	REF NO.	MFG CO.			FIG NO.	REF NO.			MFG CO.	FIG NO.	
DM15E191F0500WV4CR	72136		A8A6C23	DM15F431J300WV4CR	72136		A8A6C20	DM15F511J300WV4CR	72136	3-52	A8A6E2C4
DM15E191F0500WV4CR	72136		A8A6C29	DM15F431J300WV4CR	72136		A8A6C23	DM15F511J300WV4CR	72136	3-55	A8A7E2C21
DM15E191F0500WV4CR	72136		A8A6C34	DM15F431J300WV4CR	72136		A8A6C29	DM15F511J300WV4CR	72136	3-59	A8A7E6C156
DM15E191F0300WV4CR	72136	3-29	A8A3A10C76	DM15F431J300WV4CR	72136		A8A6C34	DM15F511J300WV4CR	72136	3-59	A8A7E6C95
DM15E221F0300WV4CR	72136	3-29	A8A3A10C74	DM15F471J300WV4CR	72136	3-37	A8A3E46C274	DM15F561J300WV4CR	72136		A8A6C14
EM15E221F0300WV4CR	72136	3-35	A8A3A12C128	DM15F471J300WV4CR	72136	3-39	A8A3E48C163	DM15F561J300WV4CR	72136		A8A6C20
EM15E251F0500WV4CR	72136	3-25	A8A3A9A2C15	DM15F471J300WV4CR	71236	3-39	A8A3E48C164	DM15F561J300WV4CR	72136		A8A6C23
EM15E271F0300WV4CR	72136	3-29	A8A3A10C72	DM15F471J300WV4CR	72136	3-39	A8A3E48C186	DM15F561J300WV4CR	72136		A8A6C29
EM15E271F0300WV4CR	72136	3-30	A8A3A11C96	DM15F471J300WV4CR	72136		A8A6C14	DM15F561J300WV4CR	72136		A8A6C34
EM15E271F0300WV4CR	72136	3-30	A8A3A11C99	DM15F471J300WV4CR	72136		A8A6C20	DM20F222J0	72136	3-20	A8A2E1C2
EM15E271F0300WV4CR	72136	3-35	A8A3A12C126	DM15F471J300WV4CR	72136		A8A6C23	DM30F153F03	72136	3-17	A8ALE1C20
EM15E271F0300WV4CR	72136	3-25	A8A3A9A2C12	DM15F471J300WV4CR	72136		A8A6C29	DM51155-5000	71468		A8A4J1A1
EM15E271F0300WV4CR	72136	3-28	A8A3A9A3C42	DM15F471J300WV4CR	72136		A8A6C34	DM51155-5000	71468		A8A4J1A2
EM15E271F0300WV4CR	72136	3-28	A8A3A9A3C45	DM15F471J300WV4CR	72136	3-57	A8A7E4C62	DM51157	71468		A8A5P11A1
DM15E2870F0500WV4CR	72136	3-35	A8A3A13C249	DM15F511J300WV4CR	72136	3-34	A8A3A4C330	DM51157	71468		A8A5P1A2
DM15E301F0300WV4CR	72136	3-25	A8A3A9A2C13	DM15F511J300WV4CR	72136	3-34	A8A3A4C333	DM53740-5000	71468		A8A2P3A1
DM15E331F0300WV4CR	72136	3-29	A8A3A10C69	DM15F511J300WV4CR	72136	3-21	A8A2E3C28	DM53740-5000	71468		A8A2P4A1
DM15E361F0300WV4CR	72136	3-29	A8A3A10C70	DM15F511J300WV4CR	72136	3-21	A8A2E3C29	DM53740-5000	71468		A8A2P4A2
DM15E431F0300WV4CR	72136	3-30	A8A3A11C97	DM15F511J300WV4CR	72136	3-21	A8A2E4C21	DM53740-5000	71468		A8A3P1A1
DM15E471F0300WV4CR	72136	3-25	A8A3A9A2C11	DM15F511J300WV4CR	72136	3-38	A8A3E47C145	DM53740-5000	71468		A8A3P1A2
DM15E471F0300WV4CR	72136	3-28	A8A3A9A3C43	DM15F511J300WV4CR	72136	3-38	A8A3E47C147	DM53740-5000	71468		A8A3P2A1
DM15E511F0300WV4CR	72136	3-29	A8A3A10C68	DM15F511J300WV4CR	72136	3-38	A8A3E47C149	DM53740-5000	71468		A8A3P2A2
DM15E511F0300WV4CR	72136	3-30	A8A3A11C95	DM15F511J300WV4CR	72136	3-38	A8A3E47C152	DM53740-5000	71468		A8A3P3A1
DM15E511F0300WV4CR	72136	3-35	A8A3A12C124	DM15F511J300WV4CR	72136	3-38	A8A3E47C155	DM53740-5000	71468		A8A3P3A2
DM15E511F0300WV4CR	72136	3-28	A8A3A9A3C41	DM15F511J300WV4CR	72136	3-38	A8A3E47C157	DM53740-5000	71468		A8A3P4A1
DM15E621J0300WV4CR	72136		A8A6C14	DM15F511J300WV4CR	72136	3-38	A8A3E47C176	DM53740-5000	71468		A8A3P1A2
DM15E621J0300WV4CR	72136		A8A6C20	DM15F511J300WV4CR	72136	3-38	A8A3E47C181	DM53740-5000	71468		A8A6P1A1
DM15E621J0300WV4CR	72136		A8A6C23	DM15F511J300WV4CR	72136	3-22	A8A3TB1C61	DM53740-5000	71468		A8A6P1A2
DM15E621J0300WV4CR	72136		A8A6C29	DM15F511J300WV4CR	72136	3-22	A8A3TB1C65	DM53740-5000	71468		A8A6P1A3
DM15E621J0300WV4CR	72136		A8A6C34	DM15F511J300WV4CR	72136	3-23	A8A3TB2C92	DM53740-5000	71468		A8A7P1A1
DM15E681G300WV4CR	72136	3-35	A8A3A12C123	DM15F511J300WV4CR	72136	3-53	A8A6A1C13	DM53740-5000	71468		A8A7P1A2
DM15E821J0300WV4CR	72136		A8A6C14	DM15F511J300WV4CR	72136	3-53	A8A6A1C21	DM53740-5000	71468		A8A7P2A1
DM15E821J0300WV4CR	72136		A8A6C20	DM15F511J300WV4CR	72136		A8A6C14	DM53740-5000	71168		A8A7P2A2
DM15E821J0300WV4CR	72136		A8A6C23	DM15F511J300WV4CR	72136		A8A6C20	DM53740-5000	71468		A8A7P2A3
DM15E821J0300WV4CR	72136		A8A6C29	DM15F511J300WV4CR	72136		A8A6C23	DM53741-5042	71468		A8A2P4A3
DM15E821J0300WV4CR	72136		A8A6C34	DM15F511J300WV4CR	72136		A8A6C29	DM53743-5058	71468		A8A4J10A1
DM15E960F0500WV4CR	72136	3-30	A6A3A11C109	DM15F511J300WV4CR	72136		A8A6C34	DM53743-5058	71468		A8A4J10A2
DM15F431J300WV4CR	72136		A8A6C14	DM15F511J300WV4CR	72136	3-52	A8A6E2C2	DM53743-5058	71468		A8A4J10A3

**SECTION IV. INDEX-FEDERAL STOCK NUMBER & REFERENCE NUMBER CROSS-REFERENCE
TO FIGURE & ITEM NUMBER (Continued)**

FEDERAL STOCK NUMBER	FIGURE NUMBER		ITEM NUMBER OR REF. DESIGNATION	FEDERAL STOCK NUMBER	FIGURE NUMBER		ITEM NUMBER OR REF. DESIGNATION	FEDERAL STOCK NUMBER	FIGURE NUMBER		ITEM NUMBER OR REF. DESIGNATION
	MFG CO.	FIG NO.			MFG CO.	FIG NO.			MFG CO.	FIG NO.	
REF NO.	MFG CO.	FIG NO.	ITEM NO OR REF DES.	REF NO.	MFG CO.	FIG NO.	ITEM NO OR REF DES.	REF NO.	MFG CO.	FIG NO.	ITEM NO OR REF DES.
DM53743-5058	71468		A8A4J11A1	HTS127-2000Z	00656	3-66	A8A4A1C11	LP51959-13M	03038		A8A3E7H2
DM53743-5058	71168		A8A4J11A2	HTS17-3000Z	00656	3-64	A8A4A16C14	LP51959-13M	03038		A8A3E7H3
DM53743-5058	71468		A84J3A2	H233PRC47	80058		HT1	LP51959-13M	03038		A8A3E7H4
DM53743-5058	71468		A8A4J4A1	1M3287	07688		A8A1A7A1CR103	LP51959-13M	03038		A8A3MP25H1
DM53743-5058	71468		A8A4J4A2	JAN1N485B	81350		A8A4TB6CR8	LP51959-13M	03038		A8A3MP25H10
DM53743-5058	71468		A8A4J4A3	JAN1N663	81350	3-66	A8A4A1CR101	LP51959-13M	03038		A8A3MP25H11
DM53743-5058	71468		A8A4J5A1	JAN1N663	81350		A8A4A7A1CR102	LP51959-13M	03038		A8A3MP25H12
DM53743-5058	71468		A8A4J5A2	JAN1N754A	81350	3-55	A8A7E2CR16	LP51959-13M	03038		A8A3MP25H13
DM53743-5058	71468		A8A4J6A1	JAN1N754A	81350	3-55	A8A7E2CR17	LP51959-13M	03038		A8A3MP25H14
DM53743-5058	71468		A6A4J6A2	JAN1N754A	81350	3-56	A87TB11CR14	LP51959-13M	03038		A8A3MF25H15
DM53743-5058	71468		A8A4J7A1	JAN1217TYPENPEN P2W5601	81350		A5E4	LP51959-13M	03038		A8A3MP25H16
DM53743-5058	71468		A8A4J7A2	JAN1217TYPENPEN P2W5601	81350		A5E5	LP51959-13M	03038		A8A3MP25H17
DM53743-5058	71468		A8A4J8A1	JAN1217TYPENPEN P2W5601	81350			LP51959-13M	03038		A8A3MP25H18
DM53743-5058	71468		A8A4J6A2	JAN2N333	81350	3-17	A8A1E1Q6	LP51959-13M	03038		A8A3MP25H19
DM53743-5058	71468		A6A4J9A1	JAN2N526	81350	3-17	A8A1E1Q5	LP51959-13M	03038		A8A3MP25H2
DM53743-5058	71468		A8A4J9A2	JAN2N526	81350	3-18	A8A1E2Q2	LP51959-13M	03038		A8A3MP25H20
DM53743-5058	71468		A8A1J9A3	JAN2N526	81350	3-18	A8A1E2Q3	LP51959-13M	03038		A8A3MP25H21
DR230	80223	3-18	A8A1E2T1	JAN2N526	81350	3-19	A88A1E3Q10	LP51959-13M	03038		A8A3MP25H22
DR905	80223	3-19	A8A1E3L3	JAN2N526	81350	3-19	A8A1E3Q8	LP51959-13M	03038		A8A3MP25H23
D144-01	08795		A8A4MP82	JAN2N526	81350	3-19	A8A1E3Q9	LP51959-13M	03038		A8A3MP25H3
D144-01	08795		A8A4MP83	JAN2N706	81350	3-56	A8A7TB1Q27	LP51959-13M	03038		A8A3MP25H4
D1910F511J0	53021	3-40	A8A3C118	JAN5907	81349	3-22	A8A3TB1V1	LP51959-13M	03038		A8A3MP25H5
D42974	56289	3-11	A8A5C19A	LP51957-28M	03038		A3E1H1	LP51959-13M	03038		A8A3MP25H6
D42974	56289	3-11	A8A5C19B	LP1957-28M	03038		A3E2H1	LP51959-13M	03038		A8A3MP25H7
FA4092	07263	3-20	A8A2E1CR1	LP51957-28M	03038		A3E3H1	LP51959-13M	03038		A8A3MP25H8
FA4092	07263	3-56	A8A7TB1CR10	LP51957-28M	03038		A3E4H1	LP51959-13M	03038		A8A3MP25H9
FA4092	07263	3-56	A8A7TB1CR11	LP51959-13M	03038		A8A2MP1H1	LP51959-13M	03038		A8A4A6E5H1
F02A250V1-2AS	81349	3-67	A8A4F3	LP51959-13M	03038		A8A2MP1H2	LP51959-13M	03038		A8A4A6E5H2
F02A250V5AS	81349		A8A4F2	LP51959-13M	03038		A8A2MP1H3	LP51959-13M	03038		A8A4A6E5H3
F03A125V20AS	81349		A8A4F1	LP51959-13M	03038		A8A2MP1H4	LP51959-13M	03038		A8A4A6ESH4
F1913-1-01	72656	3-22	A8A3TB1E3	LP51959-13M	03038		A8A2MP2H1	LP51959-13M	03038		A8A7A1H6
F1913-1-01	72656	3-23	A8A3TB2E3	LP51959-13C	03038		A8A2MP2H2	LP51959-13M	03038		A8A7MP10H1
GP4-062X0250-50	73957		A8A4A6A13MP1	LP51959-13M	03038		A8A2MP2H3	LP51959-13M	03038		A8A7MP10H2
GP4-062X0250-50	73957		A8A4A6A13MP2	LP51959-13M	03038		A8A2MP2H4	LP51959-13M	03038		A8A7MP10H3
GP4-125X0250-50	73957		A8A4A6A7A1MP3	LP51959-13M	03038		A8A3A5H6	LP51959-13M	03038		A8A7MP10H4
GP4-125X0250-50	73957		A8A4A6A7A1MP4	LP51959-13M	03038		A8A3A6H6	LP51959-13M	03038		A8A7MP10H5
G3629	01121	3-65	A8A4A7A1R117	LP51959-13M	03038		A8A3E48H4	LP51959-13M	03038		A8A7MP10H6
HP4N	09922		A8A5MP2	LP51959-13M	03038		A8A3E7H1	LP51959-13M	03038		A8A7MP11H1

**SECTION IV. INDEX-FEDERAL STOCK NUMBER & REFERENCE NUMBER CROSS-REFERENCE
TO FIGURE & ITEM NUMBER (Continued)**

FEDERAL STOCK NUMBER	FIGURE NUMBER		ITEM NUMBER OR REF. DESIGNATION	FEDERAL STOCK NUMBER	FIGURE NUMBER		ITEM NUMBER OR REF. DESIGNATION	FEDERAL STOCK NUMBER	FIGURE NUMBER		ITEM NUMBER OR REF. DESIGNATION
	MFG CO.	FIG NO.			MFG CO.	FIG NO.			MFG CO.	FIG NO.	
REF NO.	MFG CO.	FIG NO.	ITEM NO OR REF DES.	REF NO.	MFG CO.	FIG NO.	ITEM NO OR REF DES.	REF NO.	MFG CO.	FIG NO.	ITEM NO OR REF DES.
LP51959-13M	03038		A8A7MP11H2	LT10K029	81349	3-40	A8A3L120	LT10K060	81349	3-21	A8A2L9
LP51959-13M	03038		A8A7MP11H3	LT10K029	81349	3-40	A8A3L121	LT10K060	81349	3-67	A8A4L5
LP51959-13M	03038		A8A7MP11H4	LT10K029	81349	3-64	A8A4L122	LT10K060	81349	3-67	A8A4L6
LP51959-13M	03038		A8A7MP11H5	LT10K029	81349	3-64	A8A4L123	LT10K060	81349	3-53	A8A6A1L6
LP51959-13M	03038		A8A7MP11M6	LT10K029	81349	3-52	A8A6E2L2	LT10K060	81349	3-52	A8A6E1L9
LP51959-13M	03038		A8A7MP9H1	LT10K029	81349	3-55	A8A7E2L4	LT4K048	81349	3-67	A8A4L1
LP51959-13M	03038		A8A7MP9H10	LT10K029	81349	3-55	A8A7E2L7	LT4K048	81349	3-67	A8A4L2
LP51959-13M	03038		A8A7MP9H11	LT10K036	81349	3-20	A8A2E1L2	LT4K048	81349	3-67	A8A4L3
LP51959-13M	03038		A8A7MP9H12	LT10K036	81349	3-53	A8A6A1L4	MDL1-10	71400	3-67	A8A4F5
LP51959-13M	03038		A8A7MP9H13	LT10K036	81349	3-59	A8A7E6L21	MHW5455E151JQ	00853	3-64	A8A4A16C109
LP51959-13M	03038		A8A7MP9H14	LT10K036	81349	3-59	A8A7E6L22	MHW5455E151JQ	00853	3-64	A8A4A16C111
LP51959-13M	03038		A8A7MP9H2	LT10K037	81349	3-52	A8A6E1L8	MHW5455E151JQ	00853	3-64	A8A4A16C112
LP51959-13M	03038		A8A7MP9H3	LT10K043	81349	3-21	A8A2E3L8	MHW5455E151JQ	00853	3-64	A8A4A16C113
LP51959-13M	03038		A8A7MP9H4	LT10K043	81349	3-21	A8A2E4L5	MHW5455E151JQ	00853	3-64	A8A4A16C114
LP51959-13M	03038		A8A7MP9H5	LT10K043	81349	3-66	A8A4A1L102	MHW5455E501JQ	00853	3-64	A8A4A16C108
LP51959-13M	03038		A8A7MP9H6	LT10K043	81349		A8A4FL2L201	MHW5455E501JQ	00853	3-64	A8A4A16C110
LP51959-13M	03038		A8A7MP9H7	LT10K043	81349		A8A4FL2L202	MM2181	04713	3-38	A8A3E47Q3
LP51959-13M	03038		A8A7MP9H8	LT10K043	81349		A8A4FL2L203	MM2181	04713	3-38	A8A3E47Q4
LP51959-13M	03038		A8A7MP9H9	LT10K043	81349		A8A4FL2L204	MM2181	04713	3-39	A8A3E48Q11
LT10K002	81349	3-54	A87TE1L2	LT10K043	81349		A8A4FL2L205	MP206-31B	95105	3-17	A88AE1L1
LT10K003	81349	3-52	A8A6E2L1	LT10K043	81349		A8A4FL2L207	MS122119	96906		A8A3A5MP1
LT10K010	81349	3-53	A8A6A1L5	LT10K043	81349		A8A4FL2L208	MS122119	96906		A8A3A5MP2
LT10K012	81349	3-54	A8A7E1L1	LT10K043	81349		A8A4FL2L209	MS122119	96906		A8A3A6MP1
LT10K020	81349	3-39	A8A3E48L101	LT10K043	81349		A8A4FL2L210	MS122119	96906		A8A3A6MP2
LT10K020	81349	3-53	A8A6A1L3	LT10K043	81349		A8A4FL2L211	MS16221-1	96906	3-66	A8A4A1L120
LT10K020	81349	3-57	A88A7E4L16	LT10K043	81349	3-52	A8A6E1L7	MS16221-1	96906	3-66	A8A4A1L121
LT10K020	81349	3-57	A8A7E4L17	LT10K043	81349	3-61	A8A7L34	MS16221-22	96906	3-64	A8A4L105
LT10K020	81349	3-57	A8A7E4L18	LT10K043	81349	3-61	A8A7L35	MS16562-190	96906		A8A3MP22
LT10K020	81349	3-59	A8A7E6L23	LT10K043	81349	3-61	A8A7L36	MS16562-190	96906		A8A3MP23
LT10K020	81349	3-59	A8A7E6L24	LT10K043	81349	3-61	A8A7L37	MS16562-190	96906		A8A4A5MP2
LT10K020	81349	3-59	A8A7E6L25	LT10K053	81349	3-20	A8A2E1L1	MS16562-190	96906		A8A4A6A3MP2
LT110K020	81349	3-59	A8A7E6L26	LT10K053	81349	3-20	A8A2E1L3	MS16562-190	96906		A8A4L109A1MP2
LT10K020	81349	3-56	A8A7TB1L28	LT10K053	81349	3-21	A8A2L10	MS16562-190	96906		A8A4L111MP3
LT10K020	81349	3-56	A8A7TB1L29	LT10K053	81349	3-66	A8A4A1L103	MS16562-191	96906		A8A7A2MP1
LT10K020	81349	3-56	A8A7TB1L30	LT10K053	81349	3-55	A8A7E2L3	MS16562-191	96906		A8A7A3MP1
LT10K020	81349	3-56	A8A7TB1131	LT10K053	81349	3-55	A8A7E2L5	MS16562-192	96906		A8A4A6A7A3MP2
LT10K020	81349	3-56	A8A7TB1L32	LT10K053	81349	3-55	A8A7E2L6	MS16562-192	96906		A8A4A6A7A4MP2
LT10K029	81349	3-39	A8A3E48L100	LT10K053	81349	3-55	A8A7E2L8	MS16562-192	96906		A8A4A6A7MP12

**SECTION IV. INDEX-FEDERAL STOCK NUMBER & REFERENCE NUMBER CROSS-REFERENCE
TO FIGURE & ITEM NUMBER (Continued)**

FEDERAL STOCK NUMBER	FIGURE NUMBER		ITEM NUMBER OR REF. DESIGNATION	FEDERAL STOCK NUMBER	FIGURE NUMBER		ITEM NUMBER OR REF. DESIGNATION	FEDERAL STOCK NUMBER	FIGURE NUMBER		ITEM NUMBER OR REF. DESIGNATION
	MFG CO.	FIG NO.			MFG CO.	FIG NO.			MFG CO.	FIG NO.	
REF NO.	MFG CO.	FIG NO.	ITEM NO OR REF DES.	REF NO.	MFG CO.	FIG NO.	ITEM NO OR REF DES.	REF NO.	MFG CO.	FIG NO.	ITEM NO OR REF DES.
MS16562-192	96906		A8A4A6A7MP13	MS21044D04	96906		A8A57B1Q3H1	MS35338-135	96906		A3MP2H7
MS16562-197	96906		A8A3A7MP1	MS21044D04	96906		A8A57B1Q3H2	MS35338-135	96906		A3MP2H8
MS16562-197	96906		A8A3A7MP2	MS21266-1N	96906		A8A3MP10	MS35338-135	96906		A8A1E4H2
MS16562-201	96906		A8A3A8MP1	MS21266-1N	96906		A8A3MP11	MS35338-135	96906		A8A3E10H3
MS16562-203	96906		A5A1MP1	MS21266-1N	96906		A8A3MP12	MS35338-135	96906		A8A3E10H4
MS16562-206	96906		A5MP5	MS21266-1N	96906		A8A3MP13	MS35338-135	96906		A8A3E45H2
MS16562-209	96906		A8A4A6A10MP2	MS21266-1N	96906		A8A5MP6	MS35338-135	96906		A8A3E46H2
MS16562-209	96906		A8A4A6A11MP2	MS25010	96906		A8A4MP47	MS35338-135	96906		A8A3MP24H21
MS16562-209	96906		A8A4A6A9MP2	MS25010	96906		A8A4MP48	MS35338-135	96906		A8A3MP24H22
MS16562-212	96906		A8A3A6MP4	MS25010	96906		A8A4MP49	MS35338-135	96906		A8A3MP24H23
MS16562-212	96906		A8A3A6MP5	MS25010	96906		A8A4MP50	MS35338-135	96906		A8A3MP24H24
MS16562-221	96906		A8A4A6A8MP1	MS25237-387	96906		A8A4DS1	MS35338-135	96906		A8A3MP24H25
MS16562-221	96906		A8A4A6A8MP2	MS25237-387	96906		A8A4DS101	MS35338-135	96906		A8A3MP24H26
MS16620-1025	96906		A8A4A6H4	MS25237-387	96906		A8A4DS102	MS35338-135	96906		A8A3MP24H27
MS16624-1031	96906		A8A7A1A3H1	MS25237-387	96906		A8A4DS2	MS35338-135	96906		A8A3MP24H28
MS16624-1031	96906		A8A7A1A4H1	MS35200-42	96906		A8A4MP27H1	MS35338-135	96906		A8A3MP24H29
MS16624-18	96906		A8A4A6H1	MS35200-42	96906		A8A4MP27H2	MS35338-135	96906		A8A3MP24H30
MS16624-18	96906		A8A4A6H2	MS35200-42	96906		A8A4MP27H3	MS35338-135	96906		A8A3MP24H31
MS16624-18	96906		A8A4A6H3	MS35200-42	96906		A8A4MP27H4	MS35338-135	96906		A8A3MP24H32
MS16632-1018	96906		A8A4A6A7H1	MS3533-75	96906		A8A4C146H2	MS35338-135	96906		A8A3MP24H33
MS16632-1018	96906		A8A4A6H5	MS35335-51	96906		A8A5TB1H1	MS35338-135	96906		A8A3MP24H34
MS16632-1018	96906		A8A4A6H6	MS35335-51	96906		A8A5XC20H4	MS35338-135	96906		A8A3MP24H35
MS16632-1018	96906		A8A4A6H7	MS35335-51	96906		A8A7P2H3	MS35338-135	96906		A8A3MP24H36
MS16632-1018	96906		A8A4A6H8	MS35338-134	96906		A8A3E13H3	MS35338-135	96906		A8A4A15H2
MS16632-1031	96906		A8A7H1	MS35338-134	96906		A8A3E13H4	MS35338-135	96906		A8A4K5H3
MS16632-1031	96906		A8A7H2	MS35338-134	96906		A8A3E15H3	MS35338-135	96906		A8A4K5H4
MS16633-1018	96906		A8A3H10	MS35338-134	96906		A8A3E15H4	MS35338-135	96906		A8A4TB1H2
MS16633-1018	96906		A8A3H11	MS35338-134	96906		A8A4J5H6	MS35338-135	96906		A8A4TB4H5
MS16633-1018	96906		A8A3H12	MS35338-134	96906		A8A4J7H6	MS35338-135	96906		A8A4TB4H6
MS16633-1018	96906		A8A3H9	MS35338-134	96906		A8A5E5H3	MS35338-135	96906		A8A4TB6H2
MS171503	96906		A6A1A1MP3	MS35338-134	96906		A8A7MP13H4	MS35338-135	96906		A8A5E17H3
MS171503	96906		A6A2A1MP3	MS35338-134	96906		A8A7MP13H5	MS35338-135	96906		A8A5E18H2
MS171503	96906		A6A3A1MP3	MS35338-134	96906		A8A7MP13H6	MS35338-135	96906		A8A5E4H2
MS171503	96906		A6A3A1MP3	MS35338-134	96906		A8A7MP14H4	MS35338-135	96906		A8A7A1A3H1
MS17821-4-9	96906		A8A4MP21	MS35338-134	96906		A8A7MP14H5	MS35338-135	96906		A8A7E5H4
MS21044D04	96906		A6A3A1H1	MS35338-134	96906		A8A7MP14H6	MS35338-135	96906		A8A7MP8H2
MS21044D04	96906		A6A3A2H1	MS35338-135	96906		A3MP2H5	MS35338-135	96906		A8A7MP8H3
MS21044D04	96906		A8A5781E1H1	MS35338-135	96906		A3MP3H6	MS35338-135	96906		A8A7MP8H4

**SECTION IV. INDEX-FEDERAL STOCK NUMBER & REFERENCE NUMBER CROSS-REFERENCE
TO FIGURE & ITEM NUMBER (Continued)**

FEDERAL STOCK NUMBER	FIGURE NUMBER		ITEM NUMBER OR REF. DESIGNATION	FEDERAL STOCK NUMBER	FIGURE NUMBER		ITEM NUMBER OR REF. DESIGNATION	FEDERAL STOCK NUMBER	FIGURE NUMBER		ITEM NUMBER OR REF. DESIGNATION
	MFG CO.	FIG NO.			MFG CO.	FIG NO.			MFG CO.	FIG NO.	
REF NO.	MFG CO.	FIG NO.	ITEM NO OR REF DES.	REF NO.	MFG CO.	FIG NO.	ITEM NO OR REF DES.	REF NO.	MFG CO.	FIG NO.	ITEM NO OR REF DES.
MS35338-135	96906		A8A7MP8H15	MS35338-137	96906		A8A4MP78H2	MS35489-4	96906	3-56	A8A7TB1H5
MS35338-135	96906		A8A7MP8H16	MS35338-137	96906		A8A4MP79H2	MS35489-4	96906	3-56	A8A7TB1H6
MS35338-135	96906		A8A7MP8H17	MS35338-137	96906		A8A4MP80H2	MS35649-224	96906		A8A5E5H1
MS35338-135	96906		A8A7MP8H18	MS35338-137	96906		A8A4MP81H2	MS35649-225	96906		A8A1E5H1
MS35338-135	96906		A8A7MP8H19	MS35338-137	96906		A8A5MP4H2	MS35649-225	96906		A8A3E17H1
MS35338-135	96906		A8A7MP8H20	MS35338-137	96906		A8A5MP5H4	MS35649-225	96906		A8A3E18H1
MS35338-135	96906		A8A7MP8H21	MS35338-138	96906		A7A1MP10H5	MS35649-225	96906		A8A3E19H1
MS35338-135	96906		A8A7MP8H22	MS35338-138	96906		A7A1MP10H6	MS35649-225	96906		A8A3E37H1
MS35338-135	96906		A8A7P2H4	MS35338-138	96906		A7A1MP11H5	MS35649-225	96906	3-39	A8A3E48R148H1
MS35338-135	96906		A8MPH5	MS35338-138	96906		A7A1MP11H6	MS35649-225	96906		A8A3E48R148H2
MS35338-135	96906		A8MPH3	MS35338-138	96906		A7A2MP10H5	MS35649-225	96906	3-39	A8A3E48R150H1
MS35338-135	96906		A8MPH4	MS35338-138	96906		A7A2MP10H6	MS35649-225	96906		A8A3E48R501H2
MS35338-136	96906		A3E1H3	MS35338-138	96906		A7A2MP11H5	MS35649-225	96906		A8A3TB2E4H1
MS35338-136	96906		A3E2N3	MS35338-138	96906		A7A2MP11H6	MS35649-225	96906		A8A3TB2E5H1
MS35338-136	96906		A3E3H3	MS35338-96	96906		A8A4FL2E1H10	MS35649-225	96906		A8A3TB2E6H1
MS35338-136	96906		A3E4H3	MS35338-96	96906		A8A4FL2E1H11	MS35649-225	96906		A8A6P1H1
MS35338-137	96906		A8A4A6H6	MS35338-96	96906		A8A4FL2E1H12	MS35649-225	96906		A8A7TB1E10H1
MS35338-137	96906		A8A4A6MP46H3	MS35338-96	96906		A8A4FL2E1H7	MS35649-225	96906		A8A7TB1E11H1
MS35338-137	96906		A8A4A6MP46H4	MS35338-96	96906		A8A4FL2E1H8	MS35649-225	96906		A8A7TB1E12H1
MS35338-137	96906		A8A4A6MP47H3	MS35338-96	96906		A8A4FL2E1H9	MS35649-225	96906		A8A7TB1E13H1
MS35338-137	96906		A8A4A6MP47H4	MS35489-1	96906		A8A2H1	MS35649-225	96906		A8A7TB1E14H1
MS35338-137	96906		A8A4MP61H2	MS35489-1	96906		A8A4H2	MS35649-225	96906		A8A7TB1E15H1
MS35338-137	96906		A8A4MP62H2	MS35489-1	96906		A8A4H3	MS35649-225	96906		A8A7TB1E16H1
MS35338-137	96906		A8A4MP63H2	MS35489-4	96906		A8A3A4H1	MS35649-225	96906		A8A7TB1E17H1
MS35338-137	96906		A8A4MP64H2	MS35489-4	96906		A8A3A4H2	MS35649-225	96906		A8A7TB1E18H1
MS35338-137	96906		A8A4MP65H2	MS35489-4	96906		A8A3H1	MS35649-225	96906		A8A7TB1E2H1
MS35338-137	96906		A8A4MP66H2	MS35489-4	96906		A8A4H1	MS35649-225	96906		A8A7TB1E3H1
MS35338-137	96906		A8A4MP67H2	MS35489-4	96906		A8A6A1H1	MS35649-225	96906		A8A7TB1E4H1
MS35338-137	96906		A8A4MP68H2	MS35489-4	96906	3-53	A8A6A1H2	MS35649-225	96906		A8A7TB1E5H1
MS35338-137	96906		A8A4MP69H2	MS35489-4	96906	3-53	A8A6A1H3	MS35649-225	96906		A8A7TB1E6H1
MS35338-137	96906		A8A4MP70H2	MS35489-4	96906		A8A6A1H4	MS35649-225	96906		A8A7TB1E7H1
MS35338-137	96906		A8A4MSP712	MS35489-4	96906	3-52	A8A6E1H1	MS35649-225	96906		A8A7TB1E8H1
MS35338-137	96906		A8A4MP72H2	M835489-4	96906	3-52	A8A6E1H2	MS35649-225	96906		A8A7TB1E9H1
MS35338-137	96906		A8A4MP73H2	MS35489-4	96906	3-52	A8A6E1H3	MS35649-225	96906		A8A7TB1T1H1
MS35338-137	96906		A8A4MP74H2	MS35489-4	96906	3-56	A8A7TB1H1	M835649-225	96906		A8A7TB1T1H2
MS35338-137	96906		A8A4MP75H2	MS35489-4	96906	3-56	A8A7TB1H2	MS35649-225	98906		A8A7TB1T3H1
MS35338-137	96906		A8A4MP76H2	MS35489-4	96906	3-56	A8A7TB1H3	MS35649-225	96906		A8A7TB1T3H2
MS35338-137	96906		A8A7MP77H2	MS35489-4	96906	3-56	A8A7TB1H4	MS35650-304	96906		A7A1MP10H1

**SECTION IV. INDEX-FEDERAL STOCK NUMBER & REFERENCE NUMBER CROSS-REFERENCE
TO FIGURE & ITEM NUMBER (Continued)**

FEDERAL STOCK NUMBER	FIGURE NUMBER		ITEM NUMBER OR REF. DESIGNATION	FEDERAL STOCK NUMBER	FIGURE NUMBER		ITEM NUMBER OR REF. DESIGNATION	FEDERAL STOCK NUMBER	FIGURE NUMBER		ITEM NUMBER OR REF. DESIGNATION
	MFG CO.	FIG NO.			MFG CO.	FIG NO.			MFG CO.	FIG NO.	
REF NO.	MFG CO.	FIG NO.	ITEM NO OR REF DES.	REF NO.	MFG CO.	FIG NO.	ITEM NO OR REF DES.	REF NO.	MFG CO.	FIG NO.	ITEM NO OR REF DES.
MS35650-304	96906		A7A1MP10H2	MS51957-12	96906		A8A3E4H1	MS51957-13	96906		A8A4K102H3
MS35650-304	96906		A7A1MP11H1	MS51957-12	96906		A8A4K103H1	MS51957-13	96906		A8A4K102H4
MS35650-304	96906		A7A1MP11H2	MS51957-12	96906		A8A4K103H2	MS51957-13	96906		A8A4MP25H1
MS35650-304	96906		A7A2MP10H1	MS51957-12	96906		A8A5E18H1	MS51957-13	96906		A8A4MP25H10
MS35650-304	96906		A7A2MP10H2	MS51957-12	96906		A8A5E7H1	MS51957-13	96906		A8A4MP25H11
MS35650-304	96906		A7A2MP11H1	MS51957-13	96906		A8A3A2H2	MS51957-13	96906		A8A4MP25H2
MS35650-304	96906		A7A6MP11H2	M851957-13	96906		A8A3A3H2	MS51957-13	96906		A8A4MP25H3
MS35672-1	96906		A8A4A6A1MP3	MS51957-13	96906		A8A3A9A3H4	MS51957-13	96906		A8A4MP25H4
MS35672-1	96906		A8A4A6A1MP4	MS51957-13	96906		A8A3E10H1	MS51957-13	96906		A8A4MP25H5
MS35672-1	96906		A8A4A6A2MP3	MS51957-13	96906		A8A3E10H2	MS51957-13	96906		A8A4MP25H6
MS35672-1	96906		A8A4A6A2MP4	MS51957-13	96906		A8A3MP24H10	MS51957-13	96906		A8A4MP25H7
MS35672-14	96906		A7A1A1MP1	MS51957-13	96906		A8A3MP24H11	MS51957-13	96906		A8A4MP25H8
MS35672-14	96906		A7A1A2MP1	MS51957-13	96906		A8A3MP24H12	MS51957-13	96906		A8A4MP25H9
MS35672-14	96906		A7A2A1MP1	MS51957-13	96906		A8A3MP24H13	MS51957-13	96906		A8A4MP26H1
MS35672-14	96906		A7A2A2MP1	MS51957-13	96906		A8A3MP24H14	MS51957-13	96906		A8A4MP26H10
MS35672-7	96906		A8A4A6A1MP5	MS51957-13	96906		A8A3MP24H15	MS51957-13	96906		A8A4MP26H11
MS35672-7	96906		A8A4A6A2MP5	MS51957-13	96906		A8A3MP24H16	MS51957-13	96906		A8A4MP26H2
MS1053-426	96906		A8A4A6MP22H1	MS51957-13	96906		A8A3MP24H17	MS51957-13	96906		A8A4MP26H3
MS1053-426	96906		A8A4A6MP22H2	MS51957-13	96906		A8A3MP24H18	MS51957-13	96906		A8A4MP26H4
MS1053-426	96906		A8A4A6MP23H1	MS51957-13	96906		A8A3MP24H19	MS51957-13	96906		A8A4MP26H5
MS1053-426	96906		A8A4A6MP23H2	MS51957-13	96906		A8A3MP24H20	MS51957-13	96906		A8A4MP26H6
MS1053-426	96906		A8A4A6MP24H1	MS51957-13	96906		A8A3MP24H5	MS51957-13	96906		A8A4MP26H7
MS1053-426	96906		A8A4A6MP24H2	MS51957-13	96906		A8A3MP24H6	M151957-13	96906		A8A4MP26H8
MS1053-426	96906		A8A4A6MP25H1	MS51957-13	96906		A8A3MP24H7	MS51957-13	96906		A8A4MP26H9
MS1053-426	96906		A8A4A6MP25H2	MS51957-13	96906		A8A3MP24H8	MS51957-13	96906		A8A5E1H4
MS1053-426	96906		A8A4A6MP26H1	MS51957-13	96906		A8A3MP24H9	MS51957-13	96906		A8A5E17H2
MS1053-426	96906		A8A4A6MP26H2	MS51957-13	96906		A8A3MP38H1	MS51957-13	96906		A8A7A1A3H1
MS1053-426	96906		A8A4A6MP27H1	MS51957-13	96906		A8A3MP38H2	MS51957-13	96906		A8A7MP8H1
MS1053-426	96906		A8A4A6MP27H2	MS51957-13	96906		A8A3MP38H3	MS51957-13	96906		A8A7MP8H10
MS1053-426	96906		A8A4A6MP36H1	MS51957-13	96906		A8A3MP38H4	MS51957-13	96906		A8A7MP8H11
MS1053-426	96906		A8A4A6P36H2	MS51957-13	96906		A8A4E150H1	MS51957-13	96906		A8A7MP8H2
MS1053-426	96906		A8A4A6MP48H1	MS51957-13	96906		A8A4E151H1	MS51957-13	96906		A8A7MP8H3
MS1053-426	96906		A8A4A6MP48H2	MS51957-13	96906		A8A4E152H1	MK51957-13	96906		A8A7MP8H4
MS1053-426	96906		A8A4A6MP49H1	MS51957-13	96906		A8A4E153H1	MS51957-13	96906		A8A7MP8H5
MS1053-426	96906		A8A4A6MP49H2	MS51957-13	96906		A8A4E154H1	MP51957-13	96906		A8A7MP8H6
MS1053-426	96906		A8A4A6MP50H1	MS51957-13	96906		A8A4E160H1	MS51957-13	96906		A8A7MP8H7
MS1053-426	96906		A8A4A6MP50H2	MS51957-13	96906		A8A1E167H1	MS51957-13	96906		A8A7MP8H8
MS51957-12	96906		A8A3E45H1	MS51957-13	96906		A8A4E168H1	MS51957-13	96906		A8A7MP8H9

**SECTION IV. INDEX-FEDERAL STOCK NUMBER & REFERENCE NUMBER CROSS-REFERENCE
TO FIGURE & ITEM NUMBER (Continued)**

FEDERAL STOCK NUMBER	FIGURE NUMBER		ITEM NUMBER OR REF. DESIGNATION	FEDERAL STOCK NUMBER	FIGURE NUMBER		ITEM NUMBER OR REF. DESIGNATION	FEDERAL STOCK NUMBER	FIGURE NUMBER		ITEM NUMBER OR REF. DESIGNATION
	MFG CO.	FIG NO.			MFG CO.	FIG NO.			MFG CO.	FIG NO.	
REF NO.			ITEM NO OR REF DES.	REF NO.			ITEM NO OR REF DES.	REF NO.			ITEM NO OR REF DES.
MS51957-14	96906		A6A1A1H1	MS51957-15	96906		A8A4TB1H2	MS51957-28	96906		A8A4A1H2
MS51957-14	96906		A8A1MP2H1	MS51957-15	96906		A8A4TB4H1	MS51957-28	96906		A8A4A6A12H5
MS51957-14	96906		A8A1MP2H2	MS51957-15	96906		A8A4TB4H2	MS51957-28	96906		A8A5MP9H1
MS51957-14	96906		A6A2A1H1	MS51957-15	96906		A8A4TB6H2	MS51957-29	96906		A8A5MP2H2
MS51957-14	96906		A8A4A6A7H3	MS51957-15	96906		A8A5E2H4	MS51957-29	96906		A8A5T1H3
MS51957-14	96906		A8A4MP12H7	MS51957-15	96906		A8A5TB1Q3H3	MS51957-29	96906		A8A5T1H4
MS51957-14	96906		A8A4T101H1	MS51957-15	96906		A8A5TB1Q3H4	MS51957-3	96906		A8A5P1H2
MS51957-14	96906		A8A4T101H2	MS51957-15	96906		A8MP1H1	MS51957-3	96906		A8A5P1H3
MS51957-14	96906		A8A5TB1E1H2	MS51957-17	96906		A8MP1H2	MS51957-36	96906		A8A5T2H2
MS51957-14	96906		A8A5TB1H1	MS51957-19	96906		A8A3A9A1H4	MS51957-4	96906		A8A3A4H1
MS51957-14	96906		A8A7E5C72H1	MS51957-19	96906		A8A7E7A1H2	MS51957-4	96906		A8A3MP16H1
MS51957-14	96906		A8A7E5C72H2	MS51957-2	96906		A8A3E13H1	MS51957-4	96906		A8A3MP17H1
MS51957-14	96906		A8A7E5C74H1	MS51957-2	96906		A8A3E13H2	MS51957-4	96906		A8A5P1H4
MS51957-14	96906		A8A7E5C74H2	MS51957-2	96906		A8A3E15MS	MS51957-4	96906		A8A5R22H2
MS51957-14	96906		A8A7E5C76H1	MS51957-2	96906		A8A3E15H2	MS51957-4	96906		A8A5R3H2
MS51957-14	96906		A8A7E5C76H2	MS51957-2	96906		A8A3E46H2	MS51957-4	96906		A8A5R4H2
MS51957-14	96906		A8A7E5CTBH1	MS51957-2	96906		A8A7MP13H1	MS51957-4	96906		A8A7ESE2H5
MS51957-14	96906		A8A7E5CTBH2	MS51957-2	96906		A8A7MP13H2	MS51957-4	96906		A8A7E5E2H6
MS51957-14	96906		A8A7E5C80H1	MS51957-2	96906		A8A7MP13H3	MS51957-4	96906		A8A7E5E2H7
MS51957-14	96906		A8A7E5C80H2	MS51957-2	96906		A8A7MP14H1	MS51957-4	96906		A8A7E5E2H8
MS51957-14	96906		A8A7E5C82H1	MS51957-2	96906		A8A7MP14H2	MS51957-43	96906		A8A7MP4H1
MS51957-14	96906		A8A7E5C82H2	MS51957-2	96906		A8A7MP14H3	MS51957-43	96906		A8A5MP5H1
MS51957-14	96906		A8A7E5C84H1	MS51957-20	96906		A8A7E5H4	MS51957-45	96906		A8A4A6H6
MS51957-14	96906		A8A7E5C84H2	MS51957-26	96906		A8A4MP36H3	MS51957-5	96906		A8A3E48R148H3
MS51957-14	96906		A8A7E5C86H1	MS51957-26	96906		A8A4MP36H4	MS51957-5	96906		A8A3E48R148H4
MS51957-14	96906		ATB7ESC86H2	MS51957-26	96906		A8A4MP55H1	MS51957-5	96906		A8A3E48R150H3
MS51957-14	96906		A8A7E5C88MS	MS51957-26	96906		A8A4MP55H2	MS51957-5	96906		A8A3E48R150H4
MS51957-14	96906		A8A7ESC88H2	MS51957-26	96906		A8A4MP55H3	MS51958-67	96906		A6MP5H1
MS51957-14	96906		A8A7E5C90H1	MS51957-26	96906		A8A4MP55H4	MS51958-67	96906		A6MP6H1
MS51957-14	96906		A8A7E5C90H2	MS51957-26	96906		A8A4MP55H5	MS51959-1	96906		A8A4A6A5MP1H1
MS51957-14	96906		A8A7E5E1H1	MS51957-26	96906		A8A4MP55H6	MS51959-1	96906		A8A4A6A5MP1H2
MS51957-14	96906		A8A7E5E1H2	MS51957-27	96906		A8A4A1H2	MS51959-1	96906		A8A4A6A5MP1H3
MS51957-14	96906		A8A7E5E1H3	MS51957-27	96906		A8A4A6MP21H1	MS51959-1	96906		A8A4A6A5MP1H4
MS51957-14	96906		A8A7E5E1H4	MS51957-27	96906		A8A4A6MP21H2	MS51959-12	96906		A8A3A4MP1H1
MS51957-14	96906		A8MP8H1	MS51957-27	96906		A8A5A1H2	MS51959-12	96906		A8A3A4MP1H2
MS51957-15	96906		A8A4A15H2	MS51957-27	96906		A8A6MP2H1	MS51959-12	96906		A8A3A4MP1H3
MS51957-15	96906		A8A4K5H1	MS51957-27	96906		A8A6MP2H2	MS51959-12	96906		A8A3A4MP2H1
MS51957-15	96906		A8A4K5H2	MS51957-27	96906		A8MP8H2	MS51959-12	96906		A8A3A4MP2H2

**SECTION IV. INDEX-FEDERAL STOCK NUMBER & REFERENCE NUMBER CROSS-REFERENCE
TO FIGURE & ITEM NUMBER (Continued)**

FEDERAL STOCK NUMBER	FIGURE NUMBER		ITEM NUMBER OR REF. DESIGNATION	FEDERAL STOCK NUMBER	FIGURE NUMBER		ITEM NUMBER OR REF. DESIGNATION	FEDERAL STOCK NUMBER	FIGURE NUMBER		ITEM NUMBER OR REF. DESIGNATION
	MFG CO.	FIG NO.			MFG CO.	FIG NO.			MFG CO.	FIG NO.	
REF NO.	MFG CO.	FIG NO.	ITEM NO OR REF DES.	REF NO.	MFG CO.	FIG NO.	ITEM NO OR REF DES.	REF NO.	MFG CO.	FIG NO.	ITEM NO OR REF DES.
MS51959-12	96906		A8A3A4MP2H3	MS51959-13	96906		A8A7MP12H4	MS51959-3	96906		A8A3A4A1H4
MS51959-12	96906		A8A3MP24H1	MS51959-13	96906		A8A7P2H1	MS51959-3	96906		A8A3A4A2H4
MS51959-12	96906		A8A3MP24H2	MS51959-14	96906		A6A3A1H1	MS51959-3	96906		A8A3A9A1S1E1H1
MS51959-12	96906		A8A3MP24H3	MS51959-14	96906		A6A3A2H1	MS51959-3	96906		A8A3A9A1S1E1H2
MS51959-12	96906		A8A3MP24H4	MS51959-14	96906		A8A3P1H4	MS51959-3	96906		A8A3A9A2S2E1H1
MS51959-12	96906		A8A4A5MP3H1	MS51959-14	96906		A8A4MP14H1	MS51959-3	96906		A8A3A9A2S2E1H2
MS51959-12	96906		A8A4A6A3MP3H1	MS51959-14	96906		A8A5E3H2	MS51959-3	96906		A8A3A9A3S3E1H3
MS51959-12	96906		A8A4E7H1	MS51959-14	96906		A8A7P1H3	MS51959-3	96906		A8A3A9A3S3E1H4
MS51959-12	96906		A8A4E8H1	MS51959-14	96906		A8A7P1H4	MS51959-3	96906		A8A3MP39H1
MS51959-12	96906		A8A4L109A1MP3H1	MS51959-14	96906		A8A7P2H2	MS51959-3	96906		A8A3MP39H2
MS51959-12	96906		A8A4L111MP4H1	MS51959-16	96906		A6MP7H1	MS51959-3	96906		A8A3MP40H1
MS51959-12	96906		A8A5E10H1	MS51959-16	96906		A6MP7H2	MS51959-3	96906		A8A3MP40H2
MS51959-12	96906		A8A5E9H1	MS51959-2	96906		A8A3MP26H1	MS51959-3	96906		A8A1MP12H6
MS51959-12	96906		A8A5K1H1	MS51959-2	96906		A8A3MP26H2	MS51959-30	96906		A5E2H1
MS51959-12	96906		A8A5K1H2	MS51959-2	96906		A8A3MP26H3	MS51959-30	96906		A8E2H2
MS51959-13	96906		A8A1T2H1	MS51959-2	96906		A8A4A6A6MP1H1	MS51959-30	96906		A8E2H3
MS51959-13	96906		A8A1T2H2	MS51959-2	96006		A8A4A6A6MP1H2	MS51959-30	96906		A8A4A16H2
MS51959-13	96906		A8A1T2H3	MS51959-2	96906		A8A4A6A6MP1H3	MS51959-4	96906		A8A2P4H3
MS51959-13	96906		A8A1T2H4	MS51959-2	96906		A7A4A6A6MP1H4	MS51959-1	96906		A8A2P1H4
MS51959-13	96906		A8A1T3H1	MS51959-2	96906		A8A4E1H1	MS51959-4	96906		A8A5MP3H2
MS51959-13	96906		A8A1T3H2	MS51959-2	96906		A8A4E2H1	MS51959-4	96906		A8A5MP3H3
MS51959-13	96906		A8A1T3H3	MS51959-2	96906		A8A4E3H1	MS51959-41	96906		A8A4L110H1
MS51959-13	96906		A8A1T3H4	MS51959-2	96906		A8A4E4H1	MS51959-41	96906		A8A4L111H1
MS51959-13	96906		A8A1T5H1	MS51959-28	96906		A8A4K2H3	MS51960-68	96906		A7A1MP10H3
MS51959-13	96906		A8A1T5H2	MS51959-28	96906		A8A4K2H4	MS51960-68	96906		A7A1MP10H4
MS51959-13	96906		A8A1T5H3	MS51959-28	96906		A8A5T1H1	MS51960-68	96906		A7A1MP11H3
MS51959-13	96906		A8A1T5H4	MS51959-28	96906		A8A5T1H2	MS51960-68	96906		A7A1MP11H4
MS51959-13	96906		A8A3198H1	MS51959-3	96906		A8A1E1H6	MS51960-68	96906		A7A2MP10H3
MS51959-13	96906		A8A3P1H3	MS51959-3	96906		A8A1E2H6	MS51960-68	96906		A7A2MP10H4
MS51959-13	96906		A8A3P2H3	MS51959-3	96906		A8A1E3H4	MS51960-68	96906		A7A2MP11H3
MS51959-13	96906		A8A3P2H1	MS51959-3	96906		A8A2P3H3	MS51960-68	96906		A7A1MP11H4
MS51959-13	96906		A8A3P3H3	MS51959-3	96906		A8A2P3H4	MS9021-008	96906		A8A4A6MP32
MS51959-13	96906		A8A3P3H4	MS51959-3	96906		A8A3A10S4E1H1	MS9021-008	96906		A8A4A6MP33
MS51959-13	96906		A8A3P4H3	MS51959-3	96906		A8A3A10S4E1H2	MS9021-008	96906		A8A4A6MP34
MS51959-13	96906		A8A3P4H4	MS51959-3	96906		A8A3A11S5E1H1	MS9021-013	96906		A8A4H5
MS51959-13	96906		A8A7MP12H1	MS51959-3	96906		A8A3A11S5E1H2	MS2786PRC47	80058	1-1	A7
MS51959-13	96906		A8A7MP12H2	MS51959-3	96906		A8A3A12S8E1H3	MX4430PRC47	80058	1-1	A2
MS51959-13	96906		A8A7MP12H3	MS51959-3	96906		A8A3A12S8E154	M4496	91345		A8A8MP4

**SECTION IV. INDEX-FEDERAL STOCK NUMBER & REFERENCE NUMBER CROSS-REFERENCE
TO FIGURE & ITEM NUMBER (Continued)**

FEDERAL STOCK NUMBER	FIGURE NUMBER		ITEM NUMBER OR REF. DESIGNATION	FEDERAL STOCK NUMBER	FIGURE NUMBER		ITEM NUMBER OR REF. DESIGNATION	FEDERAL STOCK NUMBER	FIGURE NUMBER		ITEM NUMBER OR REF. DESIGNATION
	MFG CO.	FIG NO.			MFG CO.	FIG NO.			MFG CO.	FIG NO.	
REF NO.	MFG CO.	FIG NO.	ITEM NO OR REF DES.	REF NO.	MFG CO.	FIG NO.	ITEM NO OR REF DES.	REF NO.	MFG CO.	FIG NO.	ITEM NO OR REF DES.
NASMS190C04P3	80205		A8A2E1H4	P313-0132-000	77250		A8A3P3H2	P313-0156-000	77250		A8A3TB1E4H1
NASMS190C04P3	80205	3-20	A8A2E2H2	P313-0132-000	77250		A8A3P4H2	P313-0156-000	77250		A8A3TB1E5H1
NASMS190C04P3	80205		A8A2E3H3	P313-0132-000	77250		A8A4A16H2	P313-0156-000	77250		A8A3TB1E6H1
NASMS190C04P3	80205		A8A2E4H3	P313-0132-000	77250		A8A4A7A1H2	P313-0156-000	77250		A8A3TB2E8H1
NASMS190C04P3	80205	3-21	A8A2ESH2	P313-0132-000	77250		A8A4E37H1	P313-0156-000	77250		A8A3XV3H1
NA5MS100C04P4	80205		A8A7A1A3H2	P313-0132-000	77250		A8A4E38H1	P313-0156-000	77250		A8A3XV3H2
NM2032ZM3E	43334		A8A7MP1	P313-0132-000	77250		A8A4E39H1	P313-0156-000	77250		A8A4A16H2
NM2032ZM3E	43343		A8A7MP2	P313-0132-000	77250		A8A4E55H1	P320-0007-000	77250		A8A4E29H1
N5030B	97539		A8A4S102H1	P313-0132-000	77250		A8A4E56H1	P320-0007-000	77250		A8A4E29H2
N5030B	97539		A8A4S2H1	P313-0132-000	77250		A8A4E57H1	P320-0007-000	77250		A8A4E30H1
N5040R	97539		A8A4S3H1	P313-0132-000	77250		A8A4FL2H2	P320-0007-000	77250		A8SAE30H2
N9030-1-4	97539		A8A4A7H1	P313-0132-000	77250		A8A4K102H1	P320-0007-000	77250		A8A4E31H1
N9033-1-4	97539		A8A4R11H1	P313-0132-000	77250		A8A4K102H2	P320-0007-000	77250		A8A4E31H2
N9033-1-4	97539		A8A4S1H1	P313-0132-000	77250		A8A4MP12H1	P320-0007-000	77250		A8SAE32H1
PA234-026	71590	3-64	A8A4A16S101A	P313-0132-000	77250		A8A4MP12H2	P320-0007-000	77250		A8A4E32H2
PA234-026	71590	3-64	A8A4A16S101B	P313-0132-000	77250		A8A5E6H1	P325-0064-000	77250		A8A4Q1H3
PH6	04009		A8A4S3	P313-0132-000	77250		A8MP6H1	P325-0064-000	77250		A8A4Q1H4
PP3518PRC47	80058	3-4	A8A5	P313-0132-000	77250		A8MP6H2	P325-0064-000	77250		A8A4Q2H3
PT07C18-11P	77820		A8A4P1	P313-00140-00	77250		A8A4E35H1	P325-0064-000	77250		A8A4Q2H4
P109666	56289	3-64	A8A4C146	P313-0143-000	77250		A8A3H3	P325-0066-000	77250		A6A3MP3H3
P312-0088-000	77250		A8A4A16MP8H1	P313-0143-000	77250		A8A3H4	P325-0066-000	77250		A6A3MP3H4
P312-0088-000	77250		A8A4A16MP9H1	P313-0103-000	77250		A8A3H5	P325-0080-000	77250		A8A4A6H3
P313-0045-000	77250		A8A4A6MP55H1	P313-0143-000	77250		A8A3H6	P325-0092-000	77250		A8A3E20H2
P313-0045-000	77250		A8A4A6MP56H1	P313-0103-000	77250		A8A3H7	P325-0092-000	77250		A8A3E21H2
P313-0045-000	77250		A8A4A6MP57H1	P313-0143-000	77250		A8A3H8	P330-2253-000	77250		A8A4C122H1
P313-0045-000	77250		A8A4K2H1	P313-0156-000	77250		A8A3A4E3H1	P330-2253-000	77250		A8A4C122H2
P313-0045-000	77250		A8A4K2H2	P313-0156-000	77250		A8A3A4E4H1	P330-2284-000	77250		A8A3E17H2
P313-0045-000	77250		A8A4MP36H1	P313-0156-000	77250		A8A3E20H1	P330-2284-000	77250		A8A3E18H2
P313-0045-000	77250		A8A4MP36H2	P313-0156-000	77250		A8A3E21H1	P330-2284-000	77250		A8A3E19H2
P313-0045-000	77250		A8A4Q1H1	P313-0156-000	77250		A8A3E30H1	P330-2285-000	77250		A8A5E5H2
P313-0045-000	77250		A8A4Q1H2	P313-0156-000	77250		A8A3E31H1	P330-2286-000	77250		A8A8P1H1
P313-0045-000	77250		A8A4Q2H1	P313-0156-000	77250		A8A3E32H1	P330-2287-000	77250		A8A4J1H3
P313-0045-000	77250		A8A4Q2H2	P313-0156-000	77250		A8A3E33H1	P330-2287-000	77250		A8A4J1H4
P313-0045-000	77250		A8A5T2H1	P313-0156-000	77250		A8A3E34H1	P330-2287-000	77250		A8A4J10H3
P313-0046-000	77250		A8A4A6H9	P313-0156-000	77250		A8A3E35H1	P330-2287-000	77250		A8A4J10H4
P313-0132-000	77250		A8A3A3H2	P313-0156-000	77250		A8A3E36H1	P330-2287-000	77250		A8A4J11H3
P313-0132-000	77250		A8A3P1H2	P313-0156-000	77250		A8A3E38H1	P330-2287-000	77250		A8A4J11H4
P313-0132-000	77250		A8A3P2H2	P313-0156-000	77250		A8A3E38H2	P330-2287-000	77250		A8A4J2H3

**SECTION IV. INDEX-FEDERAL STOCK NUMBER & REFERENCE NUMBER CROSS-REFERENCE
TO FIGURE & ITEM NUMBER (Continued)**

FEDERAL STOCK NUMBER	FIGURE NUMBER		ITEM NUMBER OR REF. DESIGNATION	FEDERAL STOCK NUMBER	FIGURE NUMBER		ITEM NUMBER OR REF. DESIGNATION	FEDERAL STOCK NUMBER	FIGURE NUMBER		ITEM NUMBER OR REF. DESIGNATION
	REF NO.	MFG CO.			FIG NO.	REF NO.			MFG CO.	FIG NO.	
P330-2287-000	77250		A8A4J2H4	P330-2290-000	77250		A5A5XC19H3	P334-4120-000	77250		A8A3MP8H1
P330-2287-000	77250		A8A4J3H3	P330-2290-000	77250		A8A5XC19H4	P342-0023-000	77250		A8A4A6A8MP3H1
P330-2287-000	77250		A8A4J3H4	P330-2290-000	77250		A8A5XC20H2	P342-0024-000	77250		A8A4MP54H1
P330-2287-000	77250		A1A4J4H3	P330-2290-000	77250		A8A5XC20H3	P342-0024-000	77250		A8A4MP54H2
P330-2287-000	77250		A8A4J4H4	P330-2291-000	77250		A8A4A16H2	P342-0024-000	77250		A8A4MP54H3
P330-2287-000	77250		A8A4J5H2	P330-2291-000	77250		A8A4FL2H2	P342-0024-000	77250		A8A4MP54H4
P330-2287-000	77250		A8A4J5H3	P330-2291-000	77250		A8A4K6H3	P342-0142-000	77250		A8A3E37H2
P330-2287-000	77250		A8A4J6H3	P330-2291-000	77250		A8A4K6H4	P342-0143-000	77250		A8A1P1H3
P330-2287-000	77250		A8A4J6H4	P330-2291-000	77250		A8A4R8H3	P342-0143-000	77250		A8A1P1H4
P330-2287-000	77250		A8A4J7H2	P330-2291-000	77250		A8A4R8H4	P342-0143-000	77250		A8A6P1H2
P330-2287-000	77250		A8A4J7H3	P330-2292-000	77250		A8A4K1H3	P342-0143-000	77250		A8A6P1H3
P330-2287-000	77250		A8A4J8H3	P330-2292-000	77250		A8A4K1H4	P342-0152-000	77250		A8A3TB1H2
P330-2287-000	77250		A8A4J8H4	P330-2292-000	77250		A8A4K3H3	P342-0152-000	77250		A8A3TB2H2
P330-2288-000	77250		A8A4J9H3	P330-2292-000	77250		A8A4K3H4	P342-0152-000	77250		A8A4A16H1
P330-2288-000	77250		A8A4J9H4	P330-2292-000	77250		A8A4K4H3	P342-0153-000	77250		A8A4A16H1
P330-2290-000	77250		A8A4E37H2	P330-2292-000	77250		A8A4K4H4	P342-0165-000	77250		A8A4A6E1H1
P330-2290-000	77250		A8A4E38H2	P330-2292-000	77250		A8A4MP15H1	P342-0165-000	77250		A8A4A6E1H2
P330-2290-000	77250		A8A4E39H2	P330-2292-000	77250		A8A4MP16H1	P342-0165-000	77250		A8A4A6E2H1
P330-2290-000	77250		A8A4E55H2	P330-2292-000	77250		A8A4MP17H1	P342-0165-000	77250		A8A4A6E2H2
P330-2290-000	77250		A8A4E56H2	P330-2296-000	77250		A8A4E131H1	P342-0165-000	77250		A8A4MP90H1
P330-2290-000	77250		A8A4E57H2	P330-2296-000	77250		A8A4E24H1	P342-0165-000	77250		A8A4MP90H2
P330-2290-000	77250		A8A4TB10H1	P330-2296-000	77250		A8A4MP10H1	P342-0165-000	77250		A8A4MP91H1
P330-2290-000	77250		A8A4TB10H2	P330-2296-000	77250		A8A4MP10H2	P342-0165-000	77250		A8A4MP91H2
P330-2290-000	77250		A8A4TB8H1	P330-2296-000	77250		A8A4MP11H1	P342-0025-000	77250		A8A4A6MP20H1
P330-2290-000	77250		A8A4TB8H2	P330-2296-000	77250		A8A4MP11H2	P342-0026-000	77250		A8A4A6MP51H1
P330-2290-000	77250		A8A4TB9H1	P334-0249-000	77250		A8A4C146H1	P342-0026-000	77250		A8A4A6MP51H3
P330-2290-000	77250		A8A4TB9H2	P334-0253-000	77250		A8A4A7A1R117H1	P342-0026-000	77250		A8A4A6MP52H1
P330-2290-000	77250		A7A4T1H1	P334-0253-000	77250		A8A4R121H1	P342-0026-000	77250		A8A4A6MP53H1
P330-2290-000	77250		A8A4T1H2	P334-0254-000	77250		A8A4C29H1	P342-0026-000	77250		A8A4A6MP54H1
P330-2290-000	77250		A8A4T2H3	P334-0254-000	77250		A8A4C30H1	P342-0026-000	77250		A8A4MP12H3
P330-2290-000	77250		A8A4T2H4	P334-0284-000	77250		A2J1H1	P342-0026-000	77250		A8A4MP12H4
P330-2290-000	77250		A8A4T3H3	P334-0284-000	77250		A2J2H1	P342-0026-000	77250		A8A4MP12H5
P330-2290-000	77250		A8A4T3H4	P334-0284-000	77250		A2J2H2	P342-0162-000	77250		A8A3A4MP2H4
P330-2290-000	77250		A8A5A1H1	P334-0485-000	77250		A8A3MP12H1	P342-0162-000	77200		A8A3A4MP2H5
P330-2290-000	77250		A8A5E4H1	P334-0485-000	77250		A8A4MP22H1	P342-1958-000	77250		A8MP6H3
P330-2290-000	77250		A8A5L1H1	P334-0485-000	77250		A8A4MP23H1	P342-1958-000	77250		A8MP6H4
P330-2290-000	77250		A8A5L1H2	P334-4060-000	77250		A8A4MP13H1	P342-1959-000	77250		A8A8MP2H1
P330-2290-000	77250		A8A5MP3H1	P334-4120-000	77250		A8A3MP7H1	P342-1959-000	77250		A8A8MP2H2

**SECTION IV. INDEX-FEDERAL STOCK NUMBER & REFERENCE NUMBER CROSS-REFERENCE
TO FIGURE & ITEM NUMBER (Continued)**

FEDERAL STOCK NUMBER	FIGURE NUMBER		ITEM NUMBER OR REF. DESIGNATION	FEDERAL STOCK NUMBER	FIGURE NUMBER		ITEM NUMBER OR REF. DESIGNATION	FEDERAL STOCK NUMBER	FIGURE NUMBER		ITEM NUMBER OR REF. DESIGNATION
	REF NO.	MFG CO.			FIG NO.	REF NO.			MFG CO.	FIG NO.	
P343-0017-000	77250		A8A4MP18H1	P343-0285-000	77250		A8A2E9H1	P343-0299-000	77250		A8A3A4H2
P343-0017-000	77250		A8A4MP18H2	P343-0285-000	77250		A8A3E10H1	P343-0299-000	77250		A8A3TB2E4H2
P343-0017-000	77250		A8A4MP18H3	P343-0285-000	77250		A8A3E16H1	P343-0299-000	77250		A8A3TB2E5H2
P343-0017-000	77250		A8A4MP18H4	P343-0285-000	77250		A8A3TB1E4H2	P343-0299-000	77250		A8A3TB286H2
P343-0018-000	77250		A8A4MP53H1	P343-0285-000	77250		A8A3TB1E5H2	P343-0299-000	77250	3-52	A8A6E1H6
P343-0018-000	77250		A8A4MP53H2	P343-0285-000	77250		A8A3TB1E6H2	P343-0301-000	77250		A8A6E2R1H3
P343-0018-000	77250		A8A4MP53H3	P343-0285-000	77250		A8A3TB2E8H2	P343-0301-000	77250		A8A6E2R1H4
P343-0018-000	77250		A8A4MP53N4	P343-0285-000	77250		A8A3XV3H3	P343-0307-000	77250		A8A4E139H1
P343-0010-000	77250		A8MP5H1	P343-0285-000	77250		A8A3XV3H4	P343-0327-000	77250		A5E3H1
P343-0019-000	77250		A8MP5H2	P343-0285-000	77250		A8A4A2H2	P343-0327-000	77250		A8A4A16E3H1
P343-0023-000	77250		A8A4M101H1	P343-0286-000	77250		A8A3A13MP1H1	P343-0327-000	77250		A8A4A16E4H1
P343-0023-000	77250		A8A4M101H2	P343-0287-000	77250		A8A7E5MP3H1	P343-0327-000	77250		A8A4A16E5H1
P343-0023-000	77250		A8A4M101H3	P343-0298-000	77250		A8A3A4E1H1	P343-0327-000	77250		A8A4A16E6H1
P343-0023-000	77250		A8A4M101H4	P343-0298-000	77250		A8A3A4E2H1	P343-0327-000	77250		A8A4A16E7H1
P343-9595-000	77250		A8A4A6MP1H1	P343-0298-000	77250		A8A3A4E3H2	P343-0327-000	77250		A8A4A16E8H1
P343-0D95-000	77250		A8A4A6MP1H2	P343-0298-000	77250		A8A3A4E4H2	P343-0327-000	77250		A8A4A16E9H1
P343-0095-000	77250		A8A4A6MP1H3	P343-0298-000	77250		A8A3TB1H1	P343-0327-000	77250		A8A4C123H1
P343-0095-000	77250		A8A4A6MP1H4	P343-0298-000	77250		A8A3TB2H1	P343-0328-000	77250		A8A4A16C115H1
P343-0095-000	77250		A8A4A6MP1H5	P343-0298-000	77250	3-23	A5A3TB2K1H1	P343-0328-000	77250		A8A4A16C116H1
P343-0095-000	77250		A8A4A6MP1H6	P343-0298-000	77250	3-23	A8A3TB2K1H2	P343-0328-000	77250		A8A4A16C117H1
P343-0172-000	77250		A8A4A1A1H2	P343-0298-000	77250		A8A4FL2E1H1	P343-0328-000	77250		A8A4A16C118H1
P343-0172-000	77250		A8A4A3MP1H1	P343-0298-000	77250		A8A4FL2E1H2	P343-0328-000	77250		A8A4A16C119H1
P343-0172-000	77250		A8A4A1MP1H2	P343-0298-000	77250		A8A4FL2E1H3	P343-0328-000	77250		A8A4A16C120H1
P343-0284-000	77250	3-21	A8A2MP3H1	P343-0298-000	77250		A8A4FL2E1H4	P343-0328-000	77250		A8A4A16C121H1
P343-0284-000	77250		A8A3E30H2	P343-0298-000	77250		A8A4FL2E1H5	P343-0328-000	77250		A8A4C123H2
P343-0284-000	77250		A8A3E31H2	P343-0298-000	77250		A8A4FL2E1H6	P343-0328-000	77250		A8A4E35H2
P343-0284-000	77250		A8A3E32H2	P343-0298-000	77250		A8A6A1E1H1	P343-0328-000	77250		A8A4E41H1
P343-0284-000	77250		A8A3E33H2	P343-0298-000	77250		A8A6A1E2H1	P343-0328-000	77250		A8A4E42H1
P343-0284-000	77250		A8A3E34H2	P343-0298-000	77250		A8A6A1E3H1	P343-0329-000	77250		A8A1E1L1H1
P343-0284-000	77250		A8A3E35H2	P343-0298-000	77250		A8A6A1E4H1	P343-0329-000	77250		A8A1E1L2H1
P343-0284-000	77250		A8A3E36H2	P343-0298-000	77250		A8A6A1E5H1	P343-0330-000	77250		A8A4A16MP7H1
P343-0284-000	77250		A8A7MP7H1	P343-0298-000	77250		A8A6E1E1H1	P343-0330-000	77250		A8A4A16MP7H2
P343-0284-000	77250		A8A7MP7H2	P343-0298-000	77250		A8A6E1E2H1	P343-0330-000	77250		A8A4A6E3H1
P343-0285-000	77250		A3MP2H1	P343-0298-000	77250		A8A6E1E3H1	P343-0330-000	77250		A8A4A6E4H1
P343-0285-000	77250		A3MP2H2	P343-0298-000	77250		A8A6E1E4H1	P343-0361-000	77250		A8A6E2R2H3
P343-0285-000	77250		A3MP2H3	P343-0298-000	77250		A8A6E1E5H1	P343-0361-000	77250		A8A6E2R2H4
P343-0285-000	77250		A3MP2H4	P343-0298-000	77250		A8A6E1E6H1	P343-0382-000	77250		A8A4A16C108H1
P343-0285-000	77250		A8A1E4H1	P343-0298-000	77250		A8A1E5H2	P343-0382-000	77250		A8A4A16C109H1

**SECTION IV. INDEX-FEDERAL STOCK NUMBER & REFERENCE NUMBER CROSS-REFERENCE
TO FIGURE & ITEM NUMBER (Continued)**

FEDERAL STOCK NUMBER	FIGURE NUMBER		ITEM NUMBER OR REF. DESIGNATION	FEDERAL STOCK NUMBER	FIGURE NUMBER		ITEM NUMBER OR REF. DESIGNATION	FEDERAL STOCK NUMBER	FIGURE NUMBER		ITEM NUMBER OR REF. DESIGNATION
	MFG CO.	FIG NO.			MFG CO.	FIG NO.			MFG CO.	FIG NO.	
REF NO.			ITEM NO OR REF DES.	REF NO.			ITEM NO OR REF DES.	REF NO.			ITEM NO OR REF DES.
P343-0382-000	77250		A8A4A16C110H1	P347-0090-000	77250		A8A3MP15H3	RCR07G102KS	81349	3-22	A8A3TB1R5
P343-0382-000	77250		A8A4A16C111H1	P347-0090-000	77250		A8A3MP15H4	RCR07GC12KS	81349	3-54	A8A7E1R14
P343-0382-000	77250		A8A4A16C112H1	P347-0104-000	77250		A8A7E7A2E1H3	RCR07102GKS	81349	3-54	A8A7E1R19
P343-0382-00G	77250		A8A4A16C113H1	P347-0104-000	77250		A8A7E7A2E1H4	RCR07G102KS	81349	3-54	A8A77E1R30
P343-0382-000	77250		A8A4A16C114H1	P347-0104-000	77250		ACA7E7A2E2H3	RCR07G102KS	81349	3-55	A8A7E2R103
P347-0007-000	77250		A8A3E38H3	P347-0104-000	77250		A8A7E7A2E2H4	RCR07G102KS	81349	3-55	A8A7E2R104
P347-0021-000	77250		A8A3MP13H1	P57035	70371		A8A4A6MP1	RCR07G102KS	81349	3-55	A8A7E2R39
P347-0021-000	77250		A8A3MP14H1	Q123	03887	3-18	A8A1E2CR17	RCR07G102KS	81349	3-55	A8A7E2R50
P347-0024-000	77250		A8A3L145H1	R81J26D1018	73905		A8A4K101	RCR07G102KS	81349	3-55	A8A7E2R59
P347-0024-000	77250		A8A3L145H2	RCR05GF682K	81349	3-32	A8A3A4A2R173	RCR07G102KS	81349	3-55	A8A7E2R69
P347-0024-000	77250		A8A3114SH3	RCR05GF682K	81349	3-32	A8A3A4A2R179	RCR07C102KS	81349	3-59	A8A7E6R117
P347-0053-000	77250		A8A4A6MP46H1	RCR07G100KS	81349	3-56	A8A7TB1R144	RCR07G102KS	81349	3-56	A8A7TB1R120
P347-0053-000	77250		A8A4A6MP46H2	RCR07G101KS	81349	3-18	A8A1E2R1	RCR07G102KS	81349	3-56	A8A7TB1R144
P347-0053-000	77250		A8A4A6MP47H1	RCR07G101KS	81349	3-38	A8A3E47R41	RCR07G102KS	81349	3-56	A8A7TB7R145
P347-0053-000	77250		A8A4A6MP47H2	RCR07G101KS	81349	3-22	A8A3TB1R6	RCR07G102KS	81349	3-56	A8A7TB1R146
P347-0056-000	77250		A8A4MP61H1	RCR07G101KS	81349	3-23	A8A3TB2R11	RCR07G102KS	81349	3-56	A8A7TB1R147
P347-0056-000	77250		A8A4MP62H1	RCR07G101KS	81349	3-23	A8A3TB2R14	RCR07G103KS	81349	3-18	A8A1E2R19
P347-0056-000	77250		A8A4MP63H1	RCR07G101KS	81349	3-55	A8A7E2R45	RCR07G103KS	81349	3-19	A8A1E3R47
P347-0056-000	77250		A8A4MP64H1	RCR07G101KS	81349	3-56	A8A7TB1R131	RCR07G103KS	81349	3-19	A8A1E3R53
P3n7-0056-000	77250		A8A4MP65H1	RCR07G102KS	81349	3-21	A8A2E4R23	RCR07G103KS	81349	3-19	A8A1E3R64
P347-0056-000	77250		A8A4MP66H1	RCR07G102KS	81349	3-33	A8A3A4R161	RCR07G103KS	81349	3-19	A8A1E3R68
P347-0056-000	77250		A8A4MP67H1	RCR07G102KS	81349	3-37	A8A3E46R119	RCR07G103KS	81349	3-20	A8A2E2R14
P347-0056-000	77250		A8A4MP68H1	RCR07G102KS	81349	3-37	A8A3E46R123	RCR07G103KS	81349	3-21	A8A2E3R24
P347-0056-000	77250		A8A4MP69H1	RCR07G102KS	81349	3-37	A8A3E46R124	RCR07C103KS	81349	3-21	A8A2E4R31
P347-0056-000	77250		A8A4MP71H1	RCR07G102KS	81349	3-37	A8A3E46R128	RCR07C103KS	81349	3-21	A8A2E4R39
P347-0056-000	77250		A8A4MP77H1	RCR07G102KS	81349	3-37	A8A3E46R129	RCR07G103KS	81349	3-20	A8A2R27
P347-0056-000	77250		A8A4MP72H1	RCR07G102KS	81349	3-37	A8A3E46R133	RCR07G103KS	81349	3-38	A8A3E47R25
P347-0056-000	77250		A8A4MP73H1	RCR07G102KS	81349	3-38	A8A3E47R138	RCR07G103KS	81349	3-38	A8A3E47R44
P347-0056-000	77250		A8A4MP74H1	RCR07G102KS	81349	3-38	A8A3E47R34	RCR07G103KS	81349	3-38	A8A3E47R48
P347-0056-000	77250		A8A4MP77H1	RCR07G102KS	81349	3-38	A8A3E47R46	RCR07C103KS	81349	3-8	A8A3E47R56
P347-0056-000	77250		A8A4MP76H1	RCR07G102KS	81349	3-38	A8A3E47R47	RCR07G103KS	81349	3-39	A8A3E48R97
P347-0056-000	77250		A8A4MP77H1	RCR07G102KS	81349	3-38	A8A3E47R50	RCR07G103KS	81349	3-40	A8A3R17
P347-0056-000	77250		A8A4MP78H1	RCR07G102KS	81349	3-38	A8A3E47R51	RCR07C103KS	81349	3-22	A8A3781R1
P347-0056-000	77250		A8A4MP79H1	RCR07G102KS	81349	3-38	A8A3E47R55	RCR07G103KS	81349	3-23	A8A3782R9
P347-0056-000	77250		A8A4MP80H1	RCR07G102KS	81349	3-39	A8A3E48R59	RCR07G103KS	81349	3-53	A8A6A1R23
P347-0056-000	77250		A8A4MP81H1	RCR07G102KS	81349	3-39	A8A3E48R89	RCR07G103KS	81349	3-53	A8A6A1R28
P347-0090-000	77250		A8A3MP15H1	RCR07G102KS	81349	3-39	A8A3E48R90	RCR07G103KS	81349	3-53	A8A6A1R31
P347-0090-000	77250		A8A3MP15H2	RCR07G102KS	81349	3-41	A8A3R88	RCR07G103KS	81349	3-53	A8A6A1R32

**SECTION IV. INDEX-FEDERAL STOCK NUMBER & REFERENCE NUMBER CROSS-REFERENCE
TO FIGURE & ITEM NUMBER (Continued)**

FEDERAL STOCK NUMBER	FIGURE NUMBER		ITEM NUMBER OR REF. DESIGNATION	FEDERAL STOCK NUMBER	FIGURE NUMBER		ITEM NUMBER OR REF. DESIGNATION	FEDERAL STOCK NUMBER	FIGURE NUMBER		ITEM NUMBER OR REF. DESIGNATION
	MFG CO.	FIG NO.			MFG CO.	FIG NO.			MFG CO.	FIG NO.	
REF NO.	MFG CO.	FIG NO.	ITEM NO OR REF DES.	REF NO.	MFG CO.	FIG NO.	ITEM NO OR REF DES.	REF NO.	MFG CO.	FIG NO.	ITEM NO OR REF DES.
RCR07G103KS	81349	3-52	A8A6E1R35	RCR07G121KS	81319	3-37	A8A3E46RL25	RCR07GC53KS	81349	3-20	ABA2E2R16
RCR07G103KS	81349	3-52	A8A6E1R37	RCR07G121KS	81349	3-37	A8A3E46R130	RCR07G153KS	81349	3-37	A8A3E46R120
RCR07G103KS	81349	3-52	A8A6E1R41	RCR07G121CS	81349	3-37	A8A3E46R135	RCR07G153KS	81349		A8A6R30
RCR07G103KS	81349	3-52	A8A6E1RH2	RCR07G121KS	81349	3-38	A8A3E47R149	RCC07G153KS	81349		A8A6R45
RCR07G103KS	81349	3-52	A8A6E2R10	RCR07G121KS	81319	3-38	A8A3E47R43	RCR07G153KS	81349		A8A6R46
RCR07G103KS	81349	3-52	A8A6E2R11	RCR07G121KS	81349	3-38	A8A3E47R57	RCR07G181KS	81319	3-51	A8A7E1R12
RCR07G103KS	81349	3-52	A8A6E2R14	RCR07G121KS	81349	3-39	A8A3E48R77	RCR07G182KS	81349	3-20	A8A2E2R14
RCR07G103KS	81349	3-52	A8A6E2R15	RCR07G121KS	81349	3-39	A8A3E18R94	RCR07G182KS	81319	3-33	A8A3A4R171
RCR07G103KS	81349		A8A6R30	RCR07G121KS	81349	3-54	A8A7E1R15	RCR07G182KS	81349	3-54	A8A7E1R4
RCR07G103KS	81349		A8A6R45	RCR07G121KS	81349	3-54	A8A7E1R20	RCR07G182KS	81349	3-54	A8A7E1R7
RCR07G103KS	81349		A8A6R46	RCR07G121KS	81349	3-54	A8A7E1R31	RCR07G183KS	81349	3-19	A8A1E3R55
RCR07G103KS	81349	3-54	A8A7E1R23	RCR07G121KS	81349	3-54	A8A7E1R8	RCR07G183KS	81349	3-21	A8A2E3R22
RCR07G103KS	81349	3-54	A8A7E1R26	RCR07G121KS	81349	3-57	A8A7E4R88	RCR07G183KS	81349	3-39	A8A3E48R92
RCR07G103KS	81349	3-54	A8A7E1R3	RCR07G121KS	81349	3-57	A8A7E7R93	RCR07G183KS	81319		A8A6R30
RCR07G103KS	813h9	3-55	A8ATE2R41	RCR07G121KS	81349	3-59	A8A7E6R118	RCR07G183KS	81349		A8A6R45
RCR07G103KS	813149	3-55	A8A7E2R61	RCR07G122KS	81319	3-19	A8A1E3R72	RCR07G183xS	81349		A8A6R46
RCR07G103KS	81349	3-56	A8A7TB1R127	RCR07G123KS	81349	3-19	A8A1E3R58	RCR07G183KS	81349	3-59	A8A7E6R113
RCR07G104KS	81349	3-17	A8A1E1R34	RCR07G123KS	81349	3-19	A8A1E3178	RCR07G184KS	81349	3-19	A8ALE3R50
RCR07G104KS	81349	3-17	A8A1E1R38	RCR07G123KS	81349	3-38	A8A3E47R136	RCR07G221KS	81349	3-41	A8A3R181
RCR07G104KS	81349	3-17	A8A1E1R39	RCR07G123KS	81349	3-38	A8A3E47R137	RCR07G221KS	81349	3-53	A8A6A11R45
RCR07G104KS	81349	3-17	A8A1E1R41	RCR07G123KS	81349	3-38	A8A3E47R141	RCR07G221KS	81349	3-52	A8A6E2R17
RCR07G104KS	81349	3-17	A8A1E1R44	RCR07G123KS	81349	3-38	A8A3E47R31	RCR07G221KS	81349	3-57	A8A7E4R97
RCR07G104KS	81349	3-18	A8A1E2R13	RCR07G123KS	81349	3-38	A8A3E47R35	RCR07G221KS	81349	3-56	A8ATTB1R139
RCR07G104KS	81349	3-18	A8A1E2R28	RCR07G123KS	81349	3-38	A8A3E47R52	RCR07C221KS	81349	3-56	A8A7TB1R144
RCR07G104KS	81349	3-18	A8A1E2R4	RCR07G123KS	81349	3-38	A8A3E47R53	RCR07G222KS	81349	3-20	A8A2E2R14
RCR07G104KS	81349	3-18	A8A1E2R7	RCR07G123KS	81349	3-23	A8A3TB2R13	RCR07G222KS	81349	3-20	A8A2E2R15
RCR07G104KS	81349	3-19	A8A1E3R49	RCR07G123KS	813149		A8A6R30	RCR07G222KS	81349	3-21	A8A2E3R?0
RCR07G104KS	81349	3-19	A8A1.E3R76	RCR07G123KS	81349		A8A6R45	RCR07G222KS	81349	3-21	A8A2E3R21
RCR07G104KS	81349	3-19	A8A1E3R77	RCR07G123KS	81349		A8A6R46	RCR07G222KS	81349	3-21	A8A2E4R26
RCR07G104KS	81349	3-34	A8A3A4R165	RCR07G123KS	81349	3-55	A8A7E2R36	RCR07G222KS	81349	3-21	A8A2E4R30
RCR07G104KS	81349	3-31	A8A3A4R166	RCR07G123KS	81349	3-55	A8A7E2R56	RCR07G222KS	81349	3-38	A8A3E47R29
RCR07G104KS	81349	3-34	A8A3A4R167	RCR07G123KS	81349	3-56	A8A7TB1R128	RCR07G222KS	81349	3-38	A8A3E47R32
RCR07G104KS	81349	3-34	A8A3A4R169	RCR07G151KS	81349	3-56	A8A7TB1R144	RCR07G222KS	81345	3-39	A8A3E48R39
RCR07G104KS	81349	3-40	A8A3R19	RCR07G152KS	81349	3-19	A8A1E3R45	RCR07G222KS	81349	3-53	A8A6A1R29
RCR07G104KS	81349	3-22	A8A3TB1R2	RCR07G152KS	81349	3-20	A8A1E2R17	RCR07G222KS	813149	3-52	A8A6E1R36
RCR07G104KS	81349	3-23	A8A3TB2R10	RCR07G152KS	81349	3-21	A8A2E5R33	RCR07G222KS	81349	3-52	A8A6E2R16
RCR07G104KS	81349	3-54	A8A7E1R2	RCR07G152KS	81349	3-56	A8ATB11R143	RCR07G222KS	81349	3-54	A8A7E1R18
RCR07G104KS	81349	3-54	A8A7E1R22	RCR07G152KS	81349	3-56	A8ATTB1R144	RCR07G222KS	81349	3-54	A8A7E1R11

**SECTION IV. INDEX-FEDERAL STOCK NUMBER & REFERENCE NUMBER CROSS-REFERENCE
TO FIGURE & ITEM NUMBER (Continued)**

FEDERAL STOCK NUMBER	FIGURE NUMBER		ITEM NUMBER OR REF. DESIGNATION	FEDERAL STOCK NUMBER	FIGURE NUMBER		ITEM NUMBER OR REF. DESIGNATION	FEDERAL STOCK NUMBER	FIGURE NUMBER		ITEM NUMBER OR REF. DESIGNATION
	MFG CO.	FIG NO.			MFG CO.	FIG NO.			MFG CO.	FIG NO.	
REF NO.	MFG CO.	FIG NO.	ITEM NO OR REF DES.	REF NO.	MFG CO.	FIG NO.	ITEM NO OR REF DES.	REF NO.	MFG CO.	FIG NO.	ITEM NO OR REF DES.
RCR07G222KS	81349	3-54	A8A7E1R29	RCR07G273KS	81349	3-21	A8A2E4R32	RCR07G393KS	81349	3-59	A8A7E6R105
RCR07G222KS	81349	3-56	A8A7TB1R123	RCR07G273KS	81349	3-21	A8A2E5R34	RCR07G393KS	81349	3-59	A8A7E6R106
RCR07G223KS	81349	3-18	A8A1E2R18	RCR07G273KS	81349	3-37	A8A3E46R121	RCR07G393KS	81349	3-59	A8A7E6R107
RCR07G223KS	81349	3-18	A8A1E2R26	RCR07G273KS	81349	3-37	A8A3E46R126	RCR07G393KS	81349	3-59	A8A7E6R108
RCR07G223KS	81349	3-19	A8A1E3R48	RCR07G273KS	81349	3-37	A8A3E46R131	RCR07G393KS	81349	3-59	A8A7E6R109
RCR07G223KS	81349	3-19	A8A1E3R74	RCR07G273KS	81349	3-40	A8A3R18	RCR07G393KS	81349	3-59	A8A7E6R110
RCR07G223KS	81349	3-37	A8A3E46R122	RCR07G273KS	81349		A8A6R30	RCR07G470KS	81349	3-20	A8A2E2R13
RCR07G223KS	81349	3-37	A8A3E46R132	RCR07G273KS	81349		A8A6R45	RCR07G470KS	81349	3-56	A8A7TB1R124
RCR07G223KS	81349	3-38	A8A3E47R26	RCR07G273KS	81349		A8A6R46	RCR07G471KS	81349	3-39	A8A3E48R58
RCR07G223KS	81349	3-38	A8A3E47R27	RCR07G273KS	81349	3-59	A8A7E6R114	RCR07G471KS	81349	3-56	A8A7TB1R144
RCR07G223KS	81349	3-39	A8A3E48R93	RCR07G273KS	81349	3-56	A8A7TB1R148	RCR07G472KS	81349	3-18	A8A1ER20
RCR07G223KS	81349		A8A6R30	RCR07G274KS	81349	3-55	A8A7E2R49	RCR07G472KS	81349	3-20	A5A2E2R14
RCR07G223KS	81349		A8A6R45	RCR07G274KS	81349	3-55	A8A7E2R68	RCR07G472KS	81349	3-33	A8A3A4R159
RCR07G223KS	81349		A8A6R46	RCR07G331KS	81349	3-37	A8A3E46R134	RCR07G472KS	81349	3-38	A8A3E47R142
RCR07G223KS	81349	3-54	A8A7ER3	RCR07G331KS	81349	3-38	A8A3E47R143	RCR07G472KS	81349	3-39	A8A3E48R66
RCR07G223KS	81349	3-55	A8A7E2R40	RCR07G331KS	81349	3-56	A8A7TB1R144	RCR07G472KS	81349	3-53	A8A6A1R26
RCR07G223KS	81349	3-55	A8A8E2R60	RCR07G332KS	81349	3-19	A8A1E3R51	RCR07G472KS	81349	3-53	A8A6A1R27
RCR07G223KS	81349	3-59	A8A7E6R112	RCR07G332KS	81349	3-20	ARA2E2R14	RCR07G472KS	81349	3-52	A8A6E1R34
RCR07G223KS	81349	3-56	A8A7781R129	RCR07G332KS	81349	3-38	A8A3E47R36	RCR07G472KS	81349	3-52	A8A6E1R38
RCR07G223KS	81349		A8A7781R136	RCR07G332KS	81349	3-53	A8A6A1R24	RCR07G472KS	81349	3-52	A8A6E1R39
RCR07G223KS	81349	3-56	A8A7781R137	RCR07G332KS	81349	3-53	A8A6A1R33	RCR07G472KS	81349	3-52	A8A6E1R40
RCR07G270KS	81349	3-38	A8A3E47R24	RCR07G332KS	81349		A8A6R30	RCR07G472KS	81349	3-52	A8A6E1R43
RCR07G270KS	81349	3-38	A8A3E47R30	RCR07G332KS	81349		A8A6R45	RCR07G472KS	81349	3-52	A8A6E2R12
RCR07G272KS	81349	3-19	A8A1E3R63	RCR07G332KS	81349		A8A6R46	RCR07G772KS	81149		A8A6R30
RCR07G272KS	81349	3-20	A8A2E2R14	RCR07G333KS	81349	3-38	A8A3E47R140	RCR07G472KS	81349		A8A6R45
RCR07G272KS	81349	3-21	A8A2E14R25	RCR07G333KS	81349	3-38	A8A3E47R145	RCR07G472KS	81349		A8A6R46
RCR07G272KS	81349	3-34	A8A3A4R168	RCR07G333KS	81349	3-39	A8A3E48R62	RCR07G472KS	81349	3-54	A8A7E1R25
RCR07G272KS	81349	3-34	A8A3A4R170	RCR07G333KS	81349	3-39	A8A3E48R68	RCR07G472KS	81349	3-54	A8A7E1R28
RCR07G272KS	81349	3-39	A8A3E48R67	RCR07G333KS	81349	3-39	A8A3E48R72	RCR07G472KS	81349	3-54	A8A7E1R6
RCR07G272KS	81349	3-53	A8A6A1R25	RCR07G333KS	81349	3-59	A8A7E6R115	RCR07G472KS	81349	3-54	A8A7E1R9
RCR07G272KS	81349	3-53	A8A6R30	RCR07G390KS	81349	3-21	A8A2E5R40	RCR07G472KS	81349	3-55	A8A7E2R46
RCR07G272KS	81349		A8A6R45	RCR07G392KS	81349	3-20	A8A2E2R14	RCR07G472KS	81349	3-55	A8A7E2R65
RCR07G272KS	81349		A8A6R46	RCR07G392KS	81349		A8A6R30	RCR07G472KS	81349	3-57	A8A7E4R90
RCR07G272KS	81349	3-54	A8A7E1R17	RCR07G392KS	81349		A8A6R45	RCR07G472KS	81349	3-57	A8A7E4R99
RCR07G272KS	81349	3-59	A8A7E6R16	RCR07G392KS	81349		A8A6R46	RCR07G472KS	81349	3-56	A8A7TB1R119
RCR07G272KS	81349	3-56	A8A781R134	RCR07G392KS	81349	3-57	A8A7E4R101	RCR07G472KS	81349	3-56	A8A7TB1R130
RCR07G273KS	81349	3-19	A8A1E3R59	RCR07G392KS	81349	3-57	A8A7E4R95	RCR07G473KS	81349	3-20	A8A2E2R19
RCR07G273KS	81349	3-19	A8A1E3R73	RCR07G392KS	81349	3-56	A8A7TB1R141	RCR07G473KS	81349	3-39	A8A3E48R61

**SECTION IV. INDEX-FEDERAL STOCK NUMBER & REFERENCE NUMBER CROSS-REFERENCE
TO FIGURE & ITEM NUMBER (Continued)**

FEDERAL STOCK NUMBER	FIGURE NUMBER		ITEM NUMBER OR REF. DESIGNATION	FEDERAL STOCK NUMBER	FIGURE NUMBER		ITEM NUMBER OR REF. DESIGNATION	FEDERAL STOCK NUMBER	FIGURE NUMBER		ITEM NUMBER OR REF. DESIGNATION
	MFG CO.	FIG NO.			MFG CO.	FIG NO.			MFG CO.	FIG NO.	
REF NO.	MFG CO.	FIG NO.	ITEM NO OR REF DES.	REF NO.	MFG CO.	FIG NO.	ITEM NO OR REF DES.	REF NO.	MFG CO.	FIG NO.	ITEM NO OR REF DES.
RCR07G473KS	81349	3-39	A8A3E48R71	RCR07G681KS	81349	3-56	A8A7TB1R142	RCR20G103KS	81349	3-66	A8A4A1R103
RCR07G473KS	81349	3-54	A8A7E1R16	RCR07G681KS	81349	3-56	AA77TB1R144	RCR20G150KS	81349	3-16	A8A1R81
RCR07G473KS	81349	3-54	A8A7E1R27	RCR07G682KS	81349	3-20	A8A2E2R14	RCR20G273KS	81349	3-66	A8A4A1R119
RCR07G473KS	81349	3-55	A8A7E2R35	RCR70G682KS	81349	3-38	A8A3E47R39	RCR20G334KS	81349	3-45	A8A5R12
RCR07G473KS	81349	3-55	A8A7E2R55	RCR07G682KS	81349	3-39	A8A3E48R64	RCR20G470KS	81349	3-18	A8A1E2R2
RCR07G474KS	81349	3-19	AA1E3R775	RCR07G682KS	81349	3-39	A8A3E48R70	RCR20G471KS	81349		A8A4A7A1R129
RCR07G474KS	81349	3-39	A8A3E48R78	RCR07G682KS	81349		A8A6R30	RCR20G472KS	81349		A8A4A15R16
RCR07G874KS	81349	3-39	A8A3E48R79	RCR07G682KS	81349		A8A6R45	RCR20G473KS	81349	3-20	A8A2E2R18
RCR07G474KS	81349	3-39	A8A3E48R80	RCR07G682KS	81349		A8A6R46	RCR20G473KS	81349	3-45	A8A5R14
RCR07G474KS	81349	3-39	A8A3E48R81	RCR77G683KS	81349	3-21	A8A2E4R28	RCR20G474JS	81349	3-48	A8A8E2R2
RCR07G474KS	81349	3-52	A8A6E2R5	RCR07G683KS	81349	3-21	A8A2E5R35	RCR20G474JS	81349	3-48	A8A8E2R5
RCR07G474KS	81349	3-52	A8A6E2R6	RCR07G683KS	81349	3-39	A8A3E48R65	RCR32G101KS	81349	3-40	A8A3R20
RCR07G474KS	81349	3-54	A8A7E1R1	RCR07G683KS	81349	3-54	A8A7E1R24	RCR32G104KS	81349		A8A4A7R107
RCR07G474KS	81349	3-54	A8A7E1R21	RCR07G683KS	81349	3-54	A8A7E1R5	RCR32G104KS	81349	3-48	A8A8E2R17
RCR07G560KS	81349	3-39	A8A3E48R190	RCR07G683KS	81349	3-59	A8A7E6R111	RCR32G123KS	81349	3-48	AA8E2R1
RCR07G561KS	81349	3-21	A8A2E3R36	RCR07G683KS	81349	3-56	A8A7TB1R121	RCR32G125KS	81349	3-66	A8A4A1R115
RCR07G561KS	81349	3-21	A8A2E3R37	RCR07G683KS	81349	3-56	A8A7TB1R122	RCR32G150KS	81349	3-16	A8A1R84
RCR07G561KS	81349	3-38	A8A3E47R139	RCR07G820KS	81349	3-54	A8A7TB1R144	RCR32G152KS	81349	3-16	A8A1R79
RCR07G561KS	81349	3-38	A8A3E47R144	RCR07G821KS	81349	3-38	A8A3E47R42	RCR32G153KS	81349		A8A4R24
RCR07G561KS	81349	3-38	A8A3E47R28	RCR07G821KS	81349	3-56	A8A7781R144	RCR32G153KS	81349		A8A4R25
RCR07G561KS	81349	3-38	A8A3E47R37	RCR07G822KS	81349	3-20	A8A2E2R14	RCR32G222KS	81349	3-66	A8A4A1R116
RCR07G561KS	81349	3-38	A8A3E47R54	RCR07G822KS	81349	3-37	A8A3E46R127	RCR32G224KS	81349	3-48	A8A8E2R16
RCR07G561KS	81349	3-52	A8A6E2R13	RCR07G822KS	81349	3-38	A8A3E47R40	RCR320331KS	81349		A8A4R9
RCR07G561KS	81349	3-57	A8A7E4R102	RCR07G822KS	81349	3-38	A8A3E47R45	RCR32G335KS	81349	3-64	A8A4R112
RCR07G561KS	81349	3-57	A8A7E4R92	RCR07G822KS	8134Q	3-38	A8A3E47R49	RCR32G335KS	81349	3-64	A8A4R113
RCR07G562KS	81349	3-20	A8A2E2R14	RCR07G822KS	8134Q	3-39	A8A3E48R63	RCR32G335KS	81349	3-64	A8A4R114
RCR07G562KS	81349	3-21	A8A2E3R38	RCR07G822KS	81349	3-39	A8A3E48R69	RCR32G471KS	81349		A8A4R120
RCR07G562KS	83349	3-21	A8A2E4R29	RCR07G828KS	81349	3-39	A8A3E48R87	RCR320473KS	81349	3-66	A8A4A1R104
RCR07G562KS	81349	3-33	A8A3A4R160	RCR07G822KS	81349		A8A6R30	RCR32G561KS	81349		A8A4R125
RCR07G562KS	81349		A8A6R30	RCR07G822KS	8134Q		A8A6R45	RCR32G684KS	81349	3-48	A8A8E2R15
RCR07G562KS	81349		A8A6R45	RCR07G822KS	81349		A8A6R46	RC05GF332K	81349	3-31	A8A3A4A1R175
RCR07G562KS	81349		A8A6R46	RCR07G822KS	81349	3-57	A8A7E4R100	RC05GF332K	81349	3-31	A8A3A4A1R176
RCR07G562KS	81349	3-57	A8A7E4R91	RCR07G822KS	81349	3-56	A8A7TB1R140	RC0SGF332K	81349	3-31	A8A3A4A1R177
RCR07G562KS	81149	3-57	A8A7E4R96	RCR07G82SKS	81349	3-57	A8A7E4R89	RC05GF392K	81349	3-31	A8A3A4A1P178
RCR07G562KS	81349	3-56	A8A7TB1R151	RCRP7G825KS	81349	3-57	A8A7E4R94	RC05GF562K	81349	3-31	A8A3A4A1R174
RCR07G680KS	81349	3-22	A8A3TB1R3	RCR07G825KS	81349	3-57	A8A7E4R98	RC05GF822K	81349	3-32	A8A3A4A2R172
RCR07G680KS	81349	3-56	A8A7TB1R135	RCR20G102KS	81349		A8A4A7R118	RC42GF100K	81349	3-16	A8A1R82
RCR07G681KS	81349	3-21	A8A2R45	RCR20G103KS	81349	3-66	A8A4A1R102	RC42GF101K	81349	3-66	A8A4A1R108

**SECTION IV. INDEX-FEDERAL STOCK NUMBER & REFERENCE NUMBER CROSS-REFERENCE
TO FIGURE & ITEM NUMBER (Continued)**

FEDERAL STOCK NUMBER	FIGURE NUMBER		ITEM NUMBER OR REF. DESIGNATION	FEDERAL STOCK NUMBER	FIGURE NUMBER		ITEM NUMBER OR REF. DESIGNATION	FEDERAL STOCK NUMBER	FIGURE NUMBER		ITEM NUMBER OR REF. DESIGNATION
	MFG CO.	FIG NO.			MFG CO.	FIG NO.			MFG CO.	FIG NO.	
REF NO.	MFG CO.	FIG NO.	ITEM NO OR REF DES.	REF NO.	MFG CO.	FIG NO.	ITEM NO OR REF DES.	REF NO.	MFG CO.	FIG NO.	ITEM NO OR REF DES.
RC20GF101K	81349	3-45	A8A5R9	R160D1101F	81349	3-33	A8A3A4R156	RN60D3830F	81349	3-52	A8A6E2R18
RC42GF104K	81349		A8A4A7R105	RN60D1102F	81349	3-19	A8A183R57	RN60D42R2F	81349	3-20	A8A2E1R7
RC42GF104K	81349		A8A4A7R106	RN60D1211F	81349	3-67	A8A4R127	RN60D42R2F	81349	3-20	A8A2E1R8
RC42GF104K	81349		A8A4A7R128	RN60D1211F	81349	3-55	AA77E2R34	RN60D4220F	81349	3-51	AA85781R21
RC42GF104K	81349	3-45	A8A5R10	RN60D1211F	81349	3-55	A8A7E2R53	RN60D4220F	81349	3-51	A8A8781R23
RC42GF105K	81349	3-45	A8A5R6	RN60D1212F	81349	3-34	A8A3A4R163	RN60D4220F	81349	3-52	A8A6E2R18
RC42GF105K	81349	3-45	A8A5R71	RN60D1332F	81349	3-33	A8A3A4R158	RN60D4221F	81349	3-19	A8A1E3R66
RC42GF123K	81349	3-41	A8A3R182	RN60D1332F	81349	3-33	A8A3A4R180	RN60D46R4F	81349	3-18	A8A1E2R32
RC42GF123K	81349	3-41	A8A3R82	RN60D1470F	81349	3-20	AA2E1R1	RN60D4640F	81349	3-51	A8A5781R19
RC42GF181K	81349		A8A4R6	RN160D471F	81349	3-18	A8A1E2R22	D160D4640F	81349	3-52	A8A6E2R18
RC42GF331K	81349		A8A4R10	RN60D1622F	81349	3-19	AA11E3R60	RN60D4641F	81349	3-55	A8A7E2R37
RC42GF562K	81349		A8A4786R5	RN60D1782F	81349	3-17	A8A1E1R37	RN60D4641F	81349	3-55	8A7E2R577
RC42GF681K	81349	3-17	A8A1E1R3	RN60D1960F	81349	3-38	A8A3E47R33	RN60D4642F	81349	3-54	A8A7E1R10
RE70G4751	81349	3-67	AR84R8	RN60D1960F	81349	3-38	A8A3E47R38	RN60D51R1F	81349	3-19	A8A1E3R65
RG178BU	80058		A8A3A2W1	RN60D1961F	81349	3-18	AA1E2R17	RN60D5110F	81349	3-52	A8A6E2R18
RN60C5110F	81349	3-20	A8A2E1R4	RN60D1961F	81349	3-18	A8A1E2R25	RN60D5111F	81349	3-17	A8A1E1R43
RN60C5110F	81349	3-20	A8A2E1R6	RN60D1961F	81349	3-18	A8A1E2R31	RN60D5111F	81349	3-18	A8A1E2R16
RN60D1000F	81349	3-56	A8A7781R125	RN60D1962F	81349	3-67	A8A4R126	RN60D5111F	81349	3-19	A8A1E3R61
RN60D1000F	81349	3-56	A8A7781R126	RN60D1962F	81349	3-56	AA77781R150	RN60D5111F	81349	3-19	A8A1E3R62
RN60D1000F	81349	3-56	A8A7781R132	RN60D2151F	81349	3-17	A8A1E1R36	RN60D5111F	81349	3-55	A8A7E2R32
RN60D1000F	81349	3-56	A8A7781R133	RN60D2151F	81349	3-18	A8A1E2R111	RN6GDD11F	81349	3-55	A8A7E2R51
RN60D1001F	81349	3-18	A8A1E2R10	RN60D2151F	81349	3-51	A8A5781R20	RN60D5620F	81349	3-52	A8A6E2R18
RN60D1001F	81349	3-18	A8A1E2R14	RN60D2152F	81349	3-52	A8A6E2R9	RN60D6191F	81349	3-18	A8A1E2R29
RN60D1001F	81349	3-18	A8A1E2R23	RN60D2372F	81349	3-177	A8A1E1R35	RN60D6813F	81349		A8A4786R23
RN60D1001F	61349	3-18	A8A1E2824	RN60D26R1F	81349	3-52	A8A6E1R44	RN60D6813F	81349	3-52	A8A6E2R4
RN60D1001F	81349	3-18	A8A1E2R9	RN60D2611F	81349	3-18	A8A1E2R30	RN60D75R0F	81349	3-39	A8A3E48R146
RN60D1001F	81349	3-20	A8A2E1R3	RN60D2611F	81349	3-18	AA11E2R6	RN60D75R0F	81349	3-39	A8A3E48R147
RN60D1002F	81349	3-18	A8A1E2R12	RN60D2611F	81349	3-33	A8A3A4R157	RN60D7501F	81349	3-20	A8A2E1R2
RN60D1002F	81349	3-18	A8A1E2R21	RN60D3160F	81349	3-55	A8A7E2R38	RN60D7501F	81349	3-34	A6A3A4R164
RN60D1002F	81349	3-18	A8A1E2R5	RN60D3160F	81349	3-55	A8A7E2R58	RN60D9093F	81349	3-52	A88A6E2R4
RN60D1002F	81349	3-18	A8A1E2R8	RN60D3162F	81349	3-55	AA7A7E2R47	RN60D1001F	81349	3-18	A8A1E2R33
RN60D1002F	81349	3-19	A8A1E3R56	RN60D3162F	81349	3-55	A8A772R66	RN65D1002F	81349	3-20	A8A2E1R41
RN60D1002F	81349	3-52	A8A6E2R7	R160D3480F	81349	3-55	A8A7E2R42	RN65D1474F	81349	3-52	A8A6E2R4
RN60D1002F	81349	3-52	A8A6E2R8	RN60D3480F	81349	3-55	A8A7E2R62	RN65D1964F	81349	3-52	A8A6E2R4
RN60D1002F	81349	3-55	A8A7E2R44	RN60D3480F	81349	3-56	A8A7781R149	RTMT12M	91663		A8A3E10
RN60D1002F	81349	3-55	A8A7E2R48	RN60D3481F	81349	3-18	A8A1E2R15	RTMT12M	91663		A8A4E7
RN60D1002F	81349	3-55	A8A7E2R64	RN60D3481F	81349	3-55	A8A7E2R33	RTMT12M	91663		A8A4E8
RN60D1002F	81349	3-55	A8A7E2R67	RN60D3481F	81349	3-55	A8A7E2R54	RTMT12M	91663		A8A5E10

**SECTION IV. INDEX-FEDERAL STOCK NUMBER & REFERENCE NUMBER CROSS-REFERENCE
TO FIGURE & ITEM NUMBER (Continued)**

FEDERAL STOCK NUMBER	FIGURE NUMBER		ITEM NUMBER OR REF. DESIGNATION	FEDERAL STOCK NUMBER	FIGURE NUMBER		ITEM NUMBER OR REF. DESIGNATION	FEDERAL STOCK NUMBER	FIGURE NUMBER		ITEM NUMBER OR REF. DESIGNATION
	MFG CO.	FIG NO.			MFG CO.	FIG NO.			MFG CO.	FIG NO.	
REF NO.	MFG CO.	FIG NO.	ITEM NO OR REF DES.	REF NO.	MFG CO.	FIG NO.	ITEM NO OR REF DES.	REF NO.	MFG CO.	FIG NO.	ITEM NO OR REF DES.
R7M712M	91663	3-45	A8A5E11	S289-3497-000	94148	3-60	A8A77E77A2Y8	71566	98291		A8A1E3E3
R7M712M	91663		A8A8E7	S289-3498-000	94148	3-60	A8A7E7A2Y9	71566	98291		A8A1E3E4
R7M712M	91663	3-45	A8A8E8	S289-3499-0000	94148	3-60	A5A7E7A2Y10	72150	99707	3-65	A8A4S102
R7Mr12M	91663		A8A5E9	S289-3500-000	94148	3-60	A8A7E7A2Y11	73A361R	98978	3-22	A5A3TB1E2
R7M712M	91663		A8A7E9	S289-3501-000	94148	3-60	A8A7E7A2Y12	73A361R	98978	3-23	A8A3TB2E2
R7M716M	91663		A8A4E150	S289-3502-000	94148	3-60	A8A7E7A2y13	73103	81640		A8A4S2
R7M716M	91663		A8A4E151	S289-3503-000	94148	3-60	A8A7E7A2Y14	U239PRC47	80058	1-7	A3
R7M716M	91663		A8A4E152	S289-3504-000	94148	3-60	A8A7E7A2Y15	VC10GWY	73899	3-60	A8A7E7A2C113
R7M716M	91663		A8A4E153	S289-3505-000	94148	3-60	A8A7E7A2Y16	VC10GWY	73899	3-60	A8A7E7A2C115
R7M716M	91663		A8A4E154	S289-3506-000	94148	3-60	A8A7E7A2Y17	VC10GWY	73899	3-60	A8A7E7A2C117
R7M716M	91663		A8A4E160	S289-3507-000	94148	3-60	A8A7E7A2Y18	VC10GWY	73899	3-60	A8A7E7A2C119
R7M716M	91663		A8A4E167	S289-3508-000	94148	3-60	A8A7E7A2Y19	VC10GWY	73899	3-60	A8A7E7A2C121
R7M716M	91663		A8A4E168	S289-3509-000	94148	3-60	A8A7E7A2Y20	VC10GWY	73899	3-60	A8A7E7A2C123
RT761PRC47	80058	3-4	A8	S6316FR8N3P15102	40920		A8A3P3	VC10GWY	73899	3-60	A8A7E7A2C125
RW67V471	81349	3-67	A8A4781R3	S6316FRHN3P15102	40920		A8A3MP4	VC10GWY	73899	3-60	A8A7E7A2C127
RW67V171	81349	3-67	A8A4781R4	S6316F1NH3P15102	40920		A8A4A6MP10	VC10GWY	73899	3-60	A8A7E7A2C129
RW69V221	81349	3-45	A8A8R24	S6316FR1H3P15102	40920		A8A4A6MP2	VC10GWY	73899	3-60	A8A7E7A2C131
RW69V471	81349	3-45	A8A8R11	S6316FRFH3P15102	40920		A8A4A6MP3	VC10GWY	73899	3-60	A8A7E7A2C133
RW69V6R8	81349	3-67	A8A4781R1	S6316FRNN3P15102	40920		A8AA6MP4	VC10GWY	73899	3-60	A8A7E7A2C135
RW69V6R8	81349	3-67	A8A4781R2	S6316FRMH3P15102	40920		A8A4A6MP5	VC10GWY	73899	3-60	A8A7E7A2C137
R1412NSC41 7-32INDIA	08076		A8A9MP1	S6316FRMH3P15102	40920		A8A4A6MP6	VC10GWY	73899	3-60	A8A7E7A2C139
SA91	07886		A8A4A116MP1	S6316FRMH3P15102	10920		A8A4A6MP7	VC10GWY	73899	3-60	A8A7E7A2C141
SC883314-2A	98003		A2A1MP1	S6316FRMH3P15102	40920		A8A4A6MP8	VC100WY	73899	3-60	A8A7E7A2C143
SC883314-2A	98003		A2A2MP1	S6316FRMH3P15102	40920		A8A4A6MP9	VC10GWY	73899	3-60	A8A7E7A2C145
SC156Y	73899	3-20	A5A2E1C35	TC50-83	09052	3-33	A8A3A4C338	VC10GWY	73899	3-60	A8A7E7A2C147
SD81K03154M	53021	3-48	A8A8E2C2	TF300	98291		A8A4E1	VC10GWY	73899	3-60	A8A7E7A2C149
5M0287	96214	3-55	A8A7E2Q11	TF300	98291		A8A4E2	VC10GWY	73899	3-60	A8A7E7A2C151
SM0287	96214	3-55	AA7E2Q113	TF300	98291		A8A4E3	VC22GY	73899	3-41	A8A3C344
SR166	73138		A8A4A3MP1	TF300	98291		A8A4E4	V499	01281	3-34	A8A3A4CR10
SR166	73138		A8A4A4MP1	TF300	98291		A8A4E5	V499	01281	3-34	A8A3A4CR9
SSM-1-77	86335	3-20	A8A2E2C10	TF300	98291		A8A4E6	WAGC6347	79215		A6MP8
S289-3490-000	94148	3-60	A8A7E7A2Y1	T1TM1-4 3900-5PC	96214	3-17	A8A1E1R83	WAGC6347	79215		A6MP9
S289-3491-000	94148	3-60	A8A7E7A2Y2	T55639	94145	3-55	A8A7E2Q9	X377-1	81815	3-20	A8A2E2T2
S289-3492-000	94148	3-60	A8A7E7A2Y3	T1566	98291		A8A1E2E2	X418-1	81815	3-21	A8A2EST3
S289-3493-000	94148	3-60	A8A7E7A2Y4	T1566	98291		A8A1E2E3	X419-1	81815	3-20	A8A2E2L4
5289-3494-000	94148	3-60	A8A7E7A2Y5	T1566	98291		A8A1EFE4	X419-1	81815	3-21	A8A2E5L6
5289-3495-000	04148	3-60	A8A7E7A2Y6	T1566	98291		A8A1E2E5	X419-1	81815	3-21	A8A2ESL7
5289-3496-000	94148	3-60	A8A7E7A2Y7	T1566	98291		A8A1E3E2	X8142	92054		A8A4L109E8

**SECTION IV. INDEX-FEDERAL STOCK NUMBER & REFERENCE NUMBER CROSS-REFERENCE
TO FIGURE & ITEM NUMBER (Continued)**

FEDERAL STOCK NUMBER	FIGURE NUMBER		ITEM NUMBER OR REF. DESIGNATION	FEDERAL STOCK NUMBER	FIGURE NUMBER		ITEM NUMBER OR REF. DESIGNATION	FEDERAL STOCK NUMBER	FIGURE NUMBER		ITEM NUMBER OR REF. DESIGNATION
	REF NO.	MFG CO.			FIG NO.	REF NO.			MFG CO.	FIG NO.	
X8242	92054		A8A4L111E8	1N3641	07688	3-46	A58A8E1CR0	1N816	07688	3-17	A8A1E1CR8
YE1216F32	09922		A8A4E12	1N3641	07688	3-46	A5A8E1CR11	1N816	07688	3-18	A8A1E2CR1
YE1216F32	09922		A8A4E13	1N3641	07688	3-46	A8A5E1CR12	N816	07688	3-18	A8A1E2CR2
YE1620F32	09922		AA4E010	1N3641	07688	3-46	A5A8E1CR13	1N816	07688	3-18	A8A1E2CR3
YE1620F32	09922		A8A4E11	1N3641	07688	3-46	A8A8E1CR14	N816	07688	3-18	A8A1E2CR4
YE1620F32	09922		A8A4E9	1N3641	07688	3-46	A5A8E1CR15	1N816	07688	3-18	A8A1E2CR5
YE1620F32	09922		A8A5E12	1N3641	07688	3-46	A8A5E1CR16	1N816	07688	3-18	A8A1E2CR6
YE1620F32	09922		A8A8E13	1N3641	07688	3-46	A8A8E1CR17	1N816	07688	3-19	A5A1E3CR10
YE1620F32	09922		A8A8E14	1N3641	07688	3-46	A8A8E1CR18	1N821A	07688	3-52	A8A6E2CR1
YE1620F32	09922		A8A8E15	1N3641	07688	3-46	A8A5E1CR99	1N821A	07688	3-52	A8A6E2CR2
YE1620F32	09922		A8A8E16	1N3641	07688	3-46	A8A5E1CR20	1N916	07688	3-20	A8A2CR9
0-1032PRC47	80058	3-4	A8A6	1N3641	07688	3-46	A8A5E1CR21	1N916	07688	3-39	A8A3E48CR2
0167-3	94375		A8A4E54	1N3641	07688	3-46	A8A5E1CR22	1N916	07688	3-54	A8A741CR1
021-0187-00	98376	1-4	A1MP1	1N3641	07688	3-46	A8A5E1CR23	1N916	07688	3-55	AA77E2CR3
021-0189-000	13499		A6A3YP3	1N3641	07688	3-46	A8A5E1CR24	199116	07688	3-55	A8A7E2CR4
021-0191-00	24036		MP5	1N3641	07688	3-46	A5A5E1CR25	1N916	07688	3-59	A8A7E6CR7
021-0192-000	24036	1-3	A6MP1	1D3641	07688	3-46	A8A5E1CR6	1N916	07688	3-59	A8A7E6CR8
021-0192-000	24036	1-3	A6MP2	1N3641	07688	3-46	A8A5E1CR7	1N916	07688	3-56	A8A7711CR15
021-0192-000	24036	1-3	A6MP3	1N3641	07688	3-46	A8A5E1CR8	15911	07688	3-56	A8A7781CR9
021-0192-000	24036	1-3	A6MP4	1N3641	07688	3-46	A8A8E1CR9	10-243964-143	77820		A2MP3
021-0194-000	74284		A8MP2	1N3641	07688	3-49	A8A8E3CR1	105-731-100	74970	3-17	A8A1E1J9
021-0195-000	74284		A8A8MP1	1N3641	07688	3-49	A8A8E3CR2	105-732-100	74970	3-17	A8A1E1J12
054-0368-000	13499		A8A4FL2MP1	1N3641	07688	3-49	A8A8E3CR26	105-732-100	74970	3-18	A8A1E2J2
11N011365T1	76786		A6A4AMP1	1N3641	07688	3-49	A8A8E3CR27	105-733-100	74970	3-17	A8A1E1J10
11N01136ST1	76786		A6A44MP2	1N3641	07688	3-49	A8A8E3CR28	105-734-100	74970	3-18	A8A1E2J5
1N198	07688	3-21	A8A2E3CR7	1N3641	07688	3-49	A8A8E3CR29	105-734-100	74970	3-19	A8A1E3J15
1N198	07688	3-21	A8A2E3CR6	1N3641	07688	3-49	A8A8E3CR3	105-734-100	74970	3-38	A8A3E47J5
1N198	07688	3-39	A8A3E48CR3	1N3641	07688	3-49	A8A53CR4	105-734-100	74970	3-55	A8A7E2J5
1N198	07688	3-39	A8A3E48CR8	1N457	07688	3-17	A8A1E1CR18	105-736-100	74970	3-18	A8A1E2J3
1N198	07688	3-56	A5A7781CR12	1N457	07688	3-17	A8A1E1CR9	105-736-100	74970	3-19	A8A1E3J13
1N198	07688	3-56	A8A7781CR13	1N457	07688	3-19	A5A1E3CR11	105-737-100	74970	3-18	A8A1E2J4
1N2611	07688		A8A4786CR1	1N457	07688	3-19	A8A1E3CR12	105-737-100	74970	3-19	A8A1E3J14
1N2611	07688		A8A4786CR2	1N457	07688	3-19	A8A1E3CR13	105-738-100	74970	3-17	A5A1E1J11
1N3036A	07688	3-41	A8A3CR7	1N47958	01281	3-52	A8A6E2C12	105-738-100	74970	3-18	A8A1E2J1
1N3639	07688		A8A4A15CR3	1N645	07688	3-38	A8A3E47CR5	105-738-100	74970	3-59	A8A7E6J1
1N3639	07688		A8A4A15CR4	1N645	07688	3-38	A8A3E47CR6	105-740-100	74970	3-18	A8A1E2J6
1N3639	07688		AA4AA15CR5	1N757	07688	3-51	A8A5781CR31	105-740-100	77970	3-19	48A1E316
1N3639	07688		A8A4A15CR6	1N816	07688	3-17	A8A1E1CR7	105-740-100	74970	3-38	A8A3E47J6

**SECTION IV. INDEX-FEDERAL STOCK NUMBER & REFERENCE NUMBER CROSS-REFERENCE
TO FIGURE & ITEM NUMBER (Continued)**

FEDERAL STOCK NUMBER	FIGURE NUMBER		ITEM NUMBER OR REF. DESIGNATION	FEDERAL STOCK NUMBER	FIGURE NUMBER		ITEM NUMBER OR REF. DESIGNATION	FEDERAL STOCK NUMBER	FIGURE NUMBER		ITEM NUMBER OR REF. DESIGNATION
	MFG CO.	FIG NO.			MFG CO.	FIG NO.			MFG CO.	FIG NO.	
REF NO.	MFG CO.	FIG NO.	ITEM NO OR REF DES.	REF NO.	MFG CO.	FIG NO.	ITEM NO OR REF DES.	REF NO.	MFG CO.	FIG NO.	ITEM NO OR REF DES.
105-740-100	74970	3-55	A8A7E2J6	150D104X0035A2	56289	3-56	A5A7781C178	150D476X0006B2	56289	3-18	A8A1E2C3
105-743-100	74970	3-17	A8A1E1J8	150D104X0035A2	56289	3-56	A8A7781C179	150D476X0006B2	56289	3-18	A8A1E2C4
106-331-4	99378		A8A4MP37	150D108X0035A2	56289	3-56	A8A7781C180	150D476X0006B2	56289	3-19	A8A11E3C35
10747J	82872		W4	150D105X0035A2	56289	3-53	A8A6A1C36	150D476X0020R2	56289	3-18	A8A1E2C10
108	83330		A7A1E1P1	150D105X0035A2	56289	3-53	A8A6A1C39	150D476X0020R2	56289	3-18	A5A1E2C11
108	83330		A7A2E1P1	150D105X0035A2	56289	3-52	A8A6E1C37	150D476X0020R2	56289	3-18	A8A1E2C11
110-6	86579		A8A4A6E3H3	150D105X0035A2	56289	3-52	A8A6E1C38	150D476X0020R2	56289	3-18	A8A1E2C14
110-6	86579		A8A4A6E4H3	150D105X0035A2	56289	3-56	A8A7TB1C168	150D476X0020R2	56289	3-18	A8A1E2C15
110-6	86579		A8A8H4	150D105X9035A2	56289	3-17	A8A1E1C17	150D476X0020R2	56289	3-18	A8A1E2C6
110-8	86579		A8A4A6MPH119	150D105X9035A2	56289	3-19	A8A1E3C28	150D476X0020R2	56289	3-18	A8A1E2C7
110-8	86579		A5A4A6MP1H20	150D105X9035A2	56289	3-19	A5A1E3C34	150D476X0020R2	56289	3-19	A8A1E3C33
110-8	86579		A5A4A6MP1H21	150D105X9035A2	56289	3-21	A5A2E4C23	150D476X0035S2	56289	3-16	A8A1C44
110-8	86579		A8A4A6MP1H22	150D107X0020S2	56289	3-18	A8A1E2C12	150D476X0035S2	56289	3-17	A8A1E1C1
110-8	86579		A8A4A6MP1H23	150D107X0020S2	56289	3-18	A8A1E2C8	150D476X0035S2	56289	3-17	A8A1E1C22
110-8	86579		A8A4A6MP1H24	150D017X0020S2	56289	3-19	A8A1E3C40	150D476X0035S2	56289	3-18	A8A1E2C16
100-8	86579		A8A4A6MP46H5	150D154XC035A2	56289	3-34	A8A3A4C31	150D564X9035A2	56289	3-17	A8A1E1C26
110-8	86579		A8A4A6MP46H6	150D154XC035A2	56289	3-34	A8A3A4C32	150D684X035A2	56289	3-17	A8A1E1C26
110-8	86579		A8A4A6MP47H5	150D156X0020B2	56289	3-18	A8A1E2C5	150D685X0035B2	56289	3-21	A8A2E3C13
110-8	86579		A8A4A6MP47H6	150D156X0020B2	56289	3-19	A8A1E3C30	164-28	02660		A3P1
117WA	06980	3-65	A8A4V101	150D156X0020B2	56289	3-19	A8A1E3C31	164-7J	02660		A8A4P2
119137K	78947	3-18	A8A1E2J7	150D156X002082	56289	3-19	A8A1E3C42	164-7J	02660		A5A4P3
1218-02	78189		A8A4C29H2	150D156X002082	56289	3-21	A8A2E4C18	1700-03	78189		A8A3A3H2
1218-02	78189		A8A4C30H2	150D156X0035R2	56289	3-18	A5A1E2C2	1714-05	78189		A8A4A7A1R117H2
122-248-202	74970		A8A4A1XV101	150D1697	56209	3-17	A8A1E1C21	1804-00	78189		A8A4A2H2
1220-02	78189		A8A4MP13H2	150D1697	56289	3-17	A8A1E1C25	1806-00	78189		A8A4A16E3H2
147	23675		A4A1E1	150D1697	56289	3-19	A8A1E3C37	1806-00	78189		A8A4A16E4H2
150D104X0035A2	56289	3-21	A1A2E3C25	150D1697	56289	3-19	AA1E3C38	1806-00	78189		A8A4A16E5H2
150D101X0035A2	56289	3-21	A8A2E4C19	150D1697	56289	3-19	A8A1E3c41	1806-00	78189		A8A4A16E6H2
150D104X0035A2	56289	3-21	A8A2E4C20	15CD226X0015B2	56289	3-18	A8A1E2C9	1806-00	78189		A8A4A16E7H2
5050D10X0035A2	56289	3-39	A8A3E48C175	150D334X9035A2	56289	3-11	ANA1E1C26	1806-00	78189		A8A4A16E8H2
150D104X0035A2	56289	3-39	A8A3E48C185	150D335X0035B2	56289	3-55	A8A7E2C26	1806-00	78189		A8A4A16E9H2
150D104X0035A2	56289	3-54	A8A7E1C13	150D336X0020R2	56289	3-19	A8A1E3C32	1806-00	78189		ANA4C123H3
150D104X0035A2	56289	3-54	A8A7E1C4	150D336X0020R2	56289	3-19	A8A1E3C36	1806-00	78189		A8A4E35H3
150D010X0035A2	56289	3-54	A8A7E1C9	150D336X9010B2	56289	3-17	A8A1E1C23	1806-00	78189		A8A4E41H2
150D004X0035A2	56289	3-55	A8A7E2C92	150D336X9010B2	56289	3-17	A8A1E1C24	1806-00	78189		A5A4E42H2
150D104X0035A2	56289	3-55	A8A7E2C93	150D394X9035A2	56289	3-17	A8A1E1C26	1808-00	78189		A8A4E139H2
150D101X0035A2	56289	3-57	A8A7E4C58	150D474X0035A2	56289	3-20	A8A2C37	190-0255-000	13499		A8A41109E3
150D101X0035A2	56289	3-57	A5A7E1C61	150D474X9035A2	56289	3-17	A8A1E1C26	190-0255-000	13499		A8A41110E3

**SECTION IV. INDEX-FEDERAL STOCK NUMBER & REFERENCE NUMBER CROSS-REFERENCE
TO FIGURE & ITEM NUMBER (Continued)**

FEDERAL STOCK NUMBER	FIGURE NUMBER		ITEM NUMBER OR REF. DESIGNATION	FEDERAL STOCK NUMBER	FIGURE NUMBER		ITEM NUMBER OR REF. DESIGNATION	FEDERAL STOCK NUMBER	FIGURE NUMBER		ITEM NUMBER OR REF. DESIGNATION
	MFG CO.	FIG NO.			MFG CO.	FIG NO.			MFG CO.	FIG NO.	
REF NO.	MFG CO.	FIG NO.	ITEM NO OR REF DES.	REF NO.	MFG CO.	FIG NO.	ITEM NO OR REF DES.	REF NO.	MFG CO.	FIG NO.	ITEM NO OR REF DES.
190-0255-000	13499		A8A4L111E3	2N703	01688	3-39	A8A3E48Q9	20C119	56289		A8A8E1C7
190-0255-000	13499		A8A41112E3	2N703	07688	3-53	A8A6A1Q4	20C119	56289	3-47	A8A5E1C8
192P1039R8	56289	3-52	A8A6E1C30	2N703	07688	3-53	A8A6A1Q5	20C119	56289	3-47	ARA5E1C9
192P4729R8	56289	3-53	A8A6A1C15	2N703	07688	3-53	A8A6A1Q6	20C91A	56289	3-39	A8A3E48C179
192P4729R8	56289	3-53	A8A6A1C16	2N703	07688	3-52	A8A6E1Q7	20C91A	56289	3-59	A8A7E6C111
192P4739R8	56289	3-52	ACA6E1C31	2N703	07688	3-52	A8A6E1Q8	20C91A	56289	3-57	A8A7E6C96
2A1DB15	92825		A8A3E45	2N703	07688	3-52	A8A6E1Q9	20C91A	56289	3-59	A8A7E6C98
2A1DB15	92825		A8A3E46	2N703	07688	3-52	A8A6E2Q1	20C95	56289	3-66	A8A4A1C101
2DHT55T209CAA	71590	3-64	A8A4A16C124	2N703	07688	3-52	A8A6E1Q2	20C95	56289		A8A4A7C106
2N1038	07688	3-18	A8A1E2Q4	2N703	07688	3-52	A8A6E2Q3	2104-04-01-2520N	78189		A8A3E30
2N1166	07688	3-67	A8A1Q4	2N703	07688	3-54	A8A7E1Q1	2104-04-01-2520N	78189		A8A3E31
2N1166	07688	3-67	A8A4Q2	2N703	07688	3-54	A8A7E7Q2	2104-04-01-2520N	78189		A8A3E32
2N1485	07688	3-51	A8A5TB1Q3	2N703	07688	3-54	A8A7E1Q3	3104-04-01-2520N	78:89		A8A3E33
2N158AMATCHEDPR	07688	3-16	A8A1Q1	2N703	07688	3-54	A8A7E1Q4	2104-04-01-2520N	78189		A8A3E34
2N274	07688	3-21	A8A2E3Q2	2N703	07688	3-54	A8A7E1Q5	2104-04-01-2520N	78189		A8A3E35
2N274	07688	3-21	A8A2E4Q3	2N703	07688	3-54	A8A7E1Q6	2104-04-01-2520N	78189		A8A3E36
2N274	07688	3-21	A8A2E4Q1	2N703	07688	3-54	A8A7E1Q7	2104-04-01-2520N	78189		A8A4E37
2N274	07688	3-21	A8A2E5Q5	2N703	07688	3-57	A8A7E1Q7	1104-04-01-2520N	78189		A8A4838
2N404	07688	3-18	A8A1E2Q1	2N703	07688	3-57	A8A7E4Q18	2104-04-01-2520N	78189		A8A4E39
2N440	07688	3-20	A8A2E2Q1	2N703	07688	3-57	A8A7E4Q19	2100-04-01-2520N	78189		A8A4E40
2N697	07688	3-17	A8A2E1Q7	2N703	07688	3-59	A8A7E6Q20	2104-04-01-2520N	78189		A8A5TB1E1
2N697	07688	3-51	A8A5781Q1	2N703	07688	3-59	A7A7E6Q21	2104-04-01-2520N	78189		A8A5E6
2N697	07688	3-51	A5A5781Q2	2N703	07688	3-59	A8A7E6Q22	2104-06-02-2520N	78189		A8A4A16E3
2N697	07688	3-59	A8A7E6Q23	2N703	07688	3-56	A8A7TB1Q24	2104-06-02-2520N	78189		A8A4A1A6E4
2N703	07688	3-37	A8A3E46Q16	2N703	07688	3-56	A8A7TB1Q25	2104-06-02-2520N	78189		AAP14A16E5
2N703	07688	3-37	A8A3E46Q17	2N703	07688	3-56	A8A7TB1Q26	2104-06-02-2520N	78189		A8A4A16E6
2N703	07688	3-37	A8A3E46Q18	2N703	07688	3-56	A8A7TB1Q28	2104-06-02-2520N	78189		A8A4A16E7
2N703	07688	3-37	A8A3E46Q19	2N917	07688	3-33	A8A3A4Q20	2104-06-02-2520N	78189		A8A4A16E8
2N703	07688	3-38	A8A3E47Q12	2N917	07688	3-33	A8A3A4Q21	2104-06-02-2520N	78189		A8A4A16E9
2N703	07688	3-38	A8A3E47Q13	20C119	56289	3-47	A8A5E1C10	2104-06-02-2520N	78189		A8A4A6E6
2N703	07688	3-38	A8A3E47Q2	20C119	56289	3-47	A8A5E1C11	2104-06-02-2520N	78189		A8A4E41
2N703	07688	3-38	A8A3E47Q5	20C119	56289	3-47	A8A5E1C12	2104-06-02-2520N	78189		A8A4142
2N703	07688	3-38	A8A3E47Q6	20C119	56289	3-47	A8A5E1C13	2100-06-02-2520N	78189		A8A4E43
2N703	07688	3-38	A8A3E47Q7	20C119	56289	3-47	A8A5E1C14	2104-06-02-2520N	78189		A8A4E58
2N703	07688	3-38	A8A3E47Q8	20C119	56289	3-47	A8A5E1C3	2104-06-02-2520N	78189		ArA4E59
2N703	07688	3-39	A8A3E48Q10	20C119	56289	3-47	A8A5E1C4	2110-0216CADPL	25184		A8A8H2
2N703	07688	3-39	A8A3E48Q14	20C119	56289	3-47	A8A5E1C5	213923F1X	76854		A8A4S1
2N703	07688	3-39	A8A3E48Q15	20C119	56289	3-47	A8A5E1C6	224L1-201	80294	3-39	A8A3E48R150

**SECTION IV. INDEX-FEDERAL STOCK NUMBER & REFERENCE NUMBER CROSS-REFERENCE
TO FIGURE & ITEM NUMBER (Continued)**

FEDERAL STOCK NUMBER	FIGURE NUMBER		ITEM NUMBER OR REF. DESIGNATION	FEDERAL STOCK NUMBER	FIGURE NUMBER		ITEM NUMBER OR REF. DESIGNATION	FEDERAL STOCK NUMBER	FIGURE NUMBER		ITEM NUMBER OR REF. DESIGNATION
	MFG CO.	FIG NO.			MFG CO.	FIG NO.			MFG CO.	FIG NO.	
REF NO.	MFG CO.	FIG NO.	ITEM NO OR REF DES.	REF NO.	MFG CO.	FIG NO.	ITEM NO OR REF DES.	REF NO.	MFG CO.	FIG NO.	ITEM NO OR REF DES.
224L1-201	80294	3-11	A8A5R22	2465-009W5T0102P	72982		A8A4FL2C217	30	76545		A5E2
224L1-503	80294	3-39	A8A3E48R148	2465-009W5T0102P	72982		A8A4FL2C218	301-626C0H0409D	72982	3-24	A8A3A9A2C37
224L1-503	80294	3-11	A8A5R3	2465-009W5T0102P	72982		A8A4FL2C219	301-626C0H0409D	72982	3-24	A8A3A9A2C38
224L2-104	80294	3-11	A8A5R4	2465-009W5T0102P	72982		A8A4FL2C220	301-626C0H0509F	72982	3-24	A8A3A9A2C36
224P1-102	80294	3-19	A8A1E3R54	2465-009W5T0102P	72982		A8A4FL2C221	301-626C0H0609F	72982	3-24	A8A3A9A2C35
224P1-201	80294	3-20	A8A2E1R5	2465-009W5T0102P	72982		A8A4FL2C222	301-626C0H0709F	72982	3-24	A8A3A9A2C34
224P1-502	80294	3-17	A8A1E1R40	2865-009W5T0102P	72982		A8A4FL2C223	301-626C0H0909F	72982	3-25	A8A3A9A2C33
224P1-502	80294	3-18	A8A1E2R27	2465-009W5T0102P	72982		A8A4FL2C224	301-626C0H0309D	72982	3-25	A8A3A9A2C39
224P1-503	80294	3-19	A8A1E3R46	2465-009W5T0102P	72982		A8A4FL2C225	301-626C0H0309D	72982	3-25	A8A3A9A2C40
224P1-503	80294	3-19	A8A2E3R52	2465-009W5T0102P	72982		A8A4FL2C226	302-0016-000	13499		A8A4H13
224P1-503	80294	3-52	A8A6E2R2	2465-009W5T0102P	72982	3-61	A8A7C181	302-0016-000	13499		A8A4H14
224P1-503	80294		A8A6E2R3	2465-009W5T0102P	72982	3-61	A8A7C182	302-0016-000	13499		A8A4H15
225251N2C	76854		A8A4A7S103	2465-009W5T0102P	72982	3-61	A8A7C183	302-0016-000	13499		A8A4H16
232084FC	76854	3-34	A8A3A4S7	2465-009W5T0102P	72982	3-61	A8A7C184	302-0016-000	13499		A8A4H17
232085FC	76854	3-33	A8A3A4S10	2504-04-00-2220N	78189		A8A4A16E2	302-0016-000	13499		A8A4H18
232668FC	76854	3-33	A8A3A4S6	2522-06-00-20	78189		A3E5	302-0020-000	74921		A3E1H4
240-199-000	13499	3-40	A8A3L98	2522-06-00-20	78189		A3E6	302-0020-000	74921		A3E2H4
243200X5S0102M	72982	3-67	A8A4C29	2522-06-00-20	78189		A3E7	302-0020-000	74921		A3E3H4
243200X5S0102M	72982	3-67	A8A4C30	2522-06-00-20	78189		A3E8	302-0020-000	77492		A3E4H4
2465-008W5T0102P	72982	3-41	A8A3A2C350	28156	01121		A8A4R11	302-0023-000	05284		A8A4R22H4
2465-008W5T0102P	72982	3-41	A8A3A2C351	29F461	06001	3-20	A8A2E1C6	302-0023-000	05284		A8A5R3H4
2465-008W5T0102P	72982	3-41	A8A3A2C352	29F461	06001	3-20	A8A2E2C3	302-0023-000	05284		A8A5R4H4
2465-009W5T0102P	72982		A8A4FL2C201	3L3F	96881		A8A4A6MP11	302-0024-000	05284		A8A4A16MP10H1
2465-009W5T0102P	72982		A8A4FL2C202	3L3F	96881		A8A4A6MP12	302-0024-000	0528H		A8A4A16MP10H2
2465-009W5T0102P	72982		A8A4FL2C203	3L3F	96881		A8A4A6MP13	302-0024-000	05284		A8A4A16MP11H1
2465-009W5T0102P	72982		A8A4FL2C204	3L3F	96881		A8A4A6MP14	302-0024-000	05284		A8A4A16MP11H2
2465-009W5T0102P	72982		A8A4FL2C205	3L3F	96881		A8A4A6MP15	302-0024-000	05284		A8A4A16MP5H1
2465-009W5T0102P	72982		A8A4FL2C206	3L3F	96881		A8A4A6MP16	302-0024-000	05284		A8A4A16MA6H1
2465-009W5T0102P	72982		A8A4PL2C207	3L3F	96881		A8A4A6MP17	302-0024-000	05284		A8A4A16MP8H2
2465-009W5T0102P	77982		A8A4FL2C208	3L3F	96881		A8A7MP3	302-0024-000	05284		A8A4A16MP9H2
2465-009W5T0102P	72982		A8A4FL2C209	3SAC1025	01526	3-65	A8A4K102	302-0024-000	05284		A8A5TB1Q3H7
2465-009W5T0102P	72982		A8A4FL2C210	3SAF1242	01526	3-67	A8A4K1	302-0024-000	05284		A8A5TB1Q3H8
2465-009W5T0102P	72982		A8A4FL2C211	3SAF1242	01526	3-67	A8A4K3	302-0026-000	05284		A8A4A1A1H4
2465-009W5T0102P	72982		A8A4FL2C212	3SAF1242	01526	3-67	A8A4K4	302-0026-000	005284		A8A4A1MP1H5
2465-009W5T0102P	72982		A8A4FL2C213	35AF1242	01526	3-67	A8A4K5	302-0026-000	05284		A8A4A1MP1H8
2465-009W5T0102P	72982		A8A4FL2C214	3SAK1005	01526	3-17	A8A1E1K1	302-0026-000	05284		A8A4A1MP1H6
2465-009W5T0102P	72982		A8A4FL2C215	3SBF1054A2	01526		A8A4K6	302-0026-000	05284		A8A4A1MP1H7
2465-009W570102P	72982		A8A4FL2C216	30	76545		A5E1	302-0029-000	05284		A8A4A6MP1H13

**SECTION IV. INDEX-FEDERAL STOCK NUMBER & REFERENCE NUMBER CROSS-REFERENCE
TO FIGURE & ITEM NUMBER (Continued)**

FEDERAL STOCK NUMBER	FIGURE NUMBER		ITEM NUMBER OR REF. DESIGNATION	FEDERAL STOCK NUMBER	FIGURE NUMBER		ITEM NUMBER OR REF. DESIGNATION	FEDERAL STOCK NUMBER	FIGURE NUMBER		ITEM NUMBER OR REF. DESIGNATION
	MFG CO.	FIG NO.			MFG CO.	FIG NO.			MFG CO.	FIG NO.	
REF NO.	MFG CO.	FIG NO.	ITEM NO OR REF DES.	REF NO.	MFG CO.	FIG NO.	ITEM NO OR REF DES.	REF NO.	MFG CO.	FIG NO.	ITEM NO OR REF DES.
302-0029-000	05284		A8A4A6MP1H14	310-0045-000	79807		A8A5MP3H4	310-0071-000	79807		A8A4Q2H6
302-0029-000	05284		A8A4A6MP1H15	310-0045-000	70807		A8A5MP3H5	310-0071-000	79807		A8A5T2H5
302-0029-000	05284		A8A4A6MP1H16	310-0045-000	79807		A8A7A1A3H2	310-0074-000	79807		A8A1E5H3
302-0029-000	05284		A8A4A6MP1H17	310-0045-000	79807		A8MP1H3	310-0074-000	79807		A8A6A1E1H2
302-0029-000	05284		A8A4A6MP1H18	310-0045-000	79807		A8MP1H4	310-0074-000	79807		A8A6A1E2H2
302-0050-000	74921		A8A7TB1T1H5	310-0045-000	79807		A8MP8H3	310-0074-000	79807		A8A6A1E3H2
302-0050-000	74921		A8A7TB1T1H6	310-0046-000	79807		A8A4A1A1H1	310-0074-000	79807		A8A6A1E4H2
302-0050-000	74921		A8A7TB1T1H5	310-0046-000	79807		A8A4A1MP1H3	310-0074-000	79807		A8A6A1E5H2
302-0050-000	74921		A8A7TB1T1H6	310-0046-000	79807		A8A4A1MP1H4	310-0074-000	79807		A8A6E1E1H2
302-7000-000	74921		A3E1H5	310-0046-000	79807		A8A4A6A12H1	310-0074-000	79807		A8A6E1E2H2
302-7000-000	74921		A3E2H5	310-0046-000	79807		A8A5T2H3	310-0074-000	79807		A8A6E1E3H2
302-7000-000	74921		A3E3H5	310-0046-000	79807		A8A5T2H4	310-0074-000	79807		A8A6E1E4H2
302-7000-000	74921		A3E4H5	310-0046-000	79807		A8A6MP2H3	310-0074-000	79807		A8A6E1E5H2
303-1000-000	79807		A8A7TB1T1H7	310-0046-000	79807		A8A6MP2H4	310-0074-000	79807		A8A6E1E6H2
303-1000-000	79807		A8A7TB1T1H8	310-0048-000	79807		A8A4A6H3	310-0074-000	79807		A8A6E1H6
303-1000-000	79807		A8A7TB1T3H7	310-0048 000	79807		A8A4A6MP1H10	310-0074-000	79807		A8A6P1H6
303-1000-000	79807		A8A7TB1T3H8	310-0048-000	79807		A8A4A6MP1H11	310-0074-000	79807		A8A6P1H7
3051P1-105	80294	3-52	A8A6E2R1	310-0048-000	79807		A8A4A6MP1H12	310-0075-000	79807		A8A3A4A1E10H1
30697	97965	3-67	A8A4T3	310-0048-000	79087		A8A4A6MP1H7	310-0075-000	79807		A8A3A4A1E11H1
3100L037-1001	80294	3-21	A8A2E5K1	310-0048-000	79807		A8A4A6MP1H8	310-0075-000	79807		A8A3A4A1E12H1
310-0044-000	79807		A8A1P1H5	310-0048-000	79807		A8A4A6MP1H9	310-0075-000	79807		A8A3A4A1E9H1
310-0044-000	79807		A8A1P1H6	310-0048-000	79807		A8A5MP5H2	310-0075-000	79807		A8A3A4A1E10H1
310-0044-000	79807		A8A2P3H5	310-0048-000	79807		A8A5MP5H3	310-0075-000	79807		A8A3A4A1E11H1
310-0044-000	79807		A8A2P3H6	310-0053-000	79807		A8A3A4H2	310-0075-000	79807		A8A3A4A2E12H1
310-0044-000	79807		A8A2P4H5	310-0053-000	79807		A8A6P1H4	310-0075-000	79807		A8A3A4AE9H1
310-0044-000	79807		A8A2P4H6	310-0053-000	79807		A8A6P1H5	310-0075-000	79807		A8A3A4E1H2
310-0044-000	79807		A8A5R22H3	310-0054-000	79807		A8A4A16H2	310-0075-000	79807		A8A3A4E1H2
310-0044-000	79807		A8A5R3H3	310-0071-000	79807		A8A4A6A12H5	310-0075-000	79807		A8A3A4E3H3
310-0044 000	79807		A8A5R4H3	310-0071-000	79807		A8A4A6MP55H2	310-0075-000	79807		A8A3A4E4H3
310-0045-000	79807		A8A3L98H2	310-0071-000	79807		A8A4A6MP56H2	310-0075-000	79807		A8A3A4H1
310-0045-000	79807		A8A4A16H2	310-0071-000	798D7		A8A4A6MP57H2	310-0075-000	79807		A8A3E17H3
310-0045-000	79807		A&A4A7A1H1	310-0071-000	79807		A8A4K2H5	310-0075-000	79807		A8A3E18H3
310-0045-000	79807		A8A4FL2H4	310-0071-000	79807		A8A4K2H6	310-0075-000	79807		A8A3E19H3
310-0045 000	79807		A8A4K6H5	310-0071-000	79807		A8A4MP36H1	310-0075-000	79807		A8A3E37H3
310-0045-000	79807		A8A4MP12H8	310-0071-000	79807		A8A4MP36H5	310-0075-000	79807		A8A3TB1H1
310-0045-000	79807		A8A4MP12H9	310-0071-000	79807		A8A4Q1H5	310-0075-000	79807		A8A3TB2E4H3
310-0045-000	79807		A8A4MP01H3	310-0071-000	79807		A8A4A1H6	310-0075-000	79807		A8A3TB2ESH3
310-0045-000	79807		A8A4T101H4	310-0071-000	79807		A8A4A1H5	310-0075 000	79807		A8A3TB2E6H3

**SECTION IV. INDEX-FEDERAL STOCK NUMBER & REFERENCE NUMBER CROSS-REFERENCE
TO FIGURE & ITEM NUMBER (Continued)**

FEDERAL STOCK NUMBER	FIGURE NUMBER		ITEM NUMBER OR REF. DESIGNATION	FEDERAL STOCK NUMBER	FIGURE NUMBER		ITEM NUMBER OR REF. DESIGNATION	FEDERAL STOCK NUMBER	FIGURE NUMBER		ITEM NUMBER OR REF. DESIGNATION
	MFG CO.	FIG NO.			MFG CO.	FIG NO.			MFG CO.	FIG NO.	
REF NO.	MFG CO.	FIG NO.	ITEM NO OR REF DES.	REF NO.	MFG CO.	FIG NO.	ITEM NO OR REF DES.	REF NO.	MFG CO.	FIG NO.	ITEM NO OR REF DES.
310-0075-000	79807		A8A3TB2H1	310-0274-000	13499		A8A4E30H4	310-0395-00	79807		A8A4A16C108H2
310-0075-000	79807		A8A3TB2K1H3	310-0274-000	13499		A8A4E31H3	310-0395-00	79807		A8A4A16C109H2
310-0075-000	79807		A8A3TB2K1H4	310-0274-000	13499		A8A4E31H4	310-0395-00	79807		A8A4A16C110H2
310-0075-000	79807		A8A4E1H2	310-0274-000	13499		A8A4E32H3	310-0395-00	79807		A8A4A16C111H2
310-0075-000	79807		A8A7TB1E10H2	310-0274-000	13499		A8A4E32H4	310-0395-00	79807		A8A4A16C112H2
310-0075-000	79807		A8A7TB1E11H2	310-0278-000	70318		A8A3P1H6	310-0395-00	79807		A8A4A16C113H2
310-0075-000	79807		A8A7TB1E12H2	310-0278-000	70318		A8A3P1H7	310-0395-00	79807		A8A4A16C114H2
310-0075-000	79087		A8A7TB1E13H2	310-0278-000	70318		A8A3P2H5	310-0396-00	79807		A8A2E9H2
310-0075-000	79807		A8A7TB1E14H2	310-0278-000	70318		A8A3P3H5	310-0396-00	79807		A8A3E10H2
310-0075-000	79807		A8A7TB1E15H2	310-0278-000	70318		A3A3P4H5	310-0396-00	79807		A8A3E16H2
310-0075-000	79807		A8A7TB1E16H2	310-0278-000	70318		A8A4A16H2	310-0396-00	79807		A8A3E20H3
310-0075-000	79807		A8A7TB1E17H2	310-0278-000	70318		A8A4A6A7H3	310-0396-00	79807		A8A3E21H3
310-0075-000	79807		A8A7TB1E18H2	310-0278-000	70318		A8A4E167H2	310-0396-00	79807		A8A3E30H3
310-0075-000	79807		A8A7TB1E2H2	310-0278-000	70318		A8A4E168H2	310-0396-00	79807		A8A3E31H3
310-0075-000	79807		A8A7TB1E3H2	310-0278-000	70318		A8A4E37H4	310-0396-00	79807		A8A3E32H3
310-0075-000	79807		A8A7TB1E4H2	310-0278-000	70318		A8A4E38H4	310-0396-00	79807		A8A3E33H3
310-0075-000	79807		A8A7TB1E5H2	310-0278-000	70318		A8A4E39H4	310-0396-00	79807		A5A3E34H3
310-0075-000	79807		A8A7TB1E6H2	310-0278-000	70318		A8A4E55H3	310-0396-00	79807		A8A3E35H3
310-0075-000	79807		A8A7TB1E7H2	310-0278-000	70318		A8A4E56H3	310-0396-00	79807		A8A3E36H3
310-0075-000	79807		A8A7TB1E8H2	310-0278-000	70318		A8A4E57H4	310-0396-00	79087		A8A3E38H4
310-0075-000	79807		AHA7TB1E9H2	310-0278-000	70318		A8A4FL2H2	310-0396-00	79807		A8A3E38H5
310-0075-000	79807		A8E3H2	310-0278-000	70318		A8A4K102H5	310-0396-00	79807		A8A3MP15H5
310-0078-000	79807		A8A4A16C115H2	310-0278-000	70318		A8A4K102H6	310-0396-00	79807		A8A3MP15H6
310-0078-000	79807		A8A4A16C116H2	310-0278-000	70318		A8A4K103H3	310-0396-00	79807		A8A3MP15H7
310-0077-000	79807		A8A4A16C117H2	310-0278-000	70318		A8A4K103H4	310-0396-00	79807		A8A3MP15H8
310-0078-000	79807		A8A4A16C118H2	310-0278-000	70318		A8A4MP12H10	310-0396-00	79807		A8A3TP1E4H3
310-0078-000	79807		A8A4A16C119H2	310-0278-000	70318		A8A4MP12H11	310-0396-00	79807		A8A3TP1E5H3
310-0078-000	79807		A8A4A16C120H2	310-0278-000	70318		A8A4MP22H3	310-0396-00	79807		A8A3TP1E6H3
310-0078-000	79807		A8A4A16C121H2	310-0278-000	70318		A8A4MP23H3	310-0396-00	79807		A8A3TP2E8H3
310-0078-000	79807		A8A4A16MP7H3	310-0280-000	70318		A8A8MP5H10	310-0396-00	79087		A8A3XV3H5
310-0078-000	79807		A8A4A16MP7H4	310-0280-000	70318		A8A8MP5H11	310-0396-00	79087		A8A3XV3H6
310-0078-000	79807		A8A4A6E3H2	310-0280-000	70318		A8A8MP5H12	310-0396-00	79087		A8A4A16H2
310-0078-000	79807		A8A4A6E4H2	310-0280-000	70318		A8A8MP5H13	310-0396-00	79087		A8A7MP7H3
310-0078-000	79807		A8A4C123R4	310-0280-000	70318		A8A8MP5H14	310-0396-00	79807		A8A7MP7H4
310-0082-000	79807		A8A4R121H2	310-0280-000	70318		A8A8MP5H15	310-0397-00	79807		A8A3A4A1L125H2
310-0274-000	13499		A8A4E29H3	310-0280-000	70318		A8A8MP5H16	310-0397-00	79807		A8A3A4A1L126H2
310-0274-000	13499		A8A4E29H4	310-0280-000	70318		A8A8MP5H9	310-0397-00	79807		A8A3A4A1L127H2
310-0274-000	13499		A8A4E30H3	310-0283-000	70318		A8A4A6H3	310-0397-00	79807		A8A3A4A2L128H2

**SECTION IV. INDEX-FEDERAL STOCK NUMBER & REFERENCE NUMBER CROSS-REFERENCE
TO FIGURE & ITEM NUMBER (Continued)**

FEDERAL STOCK NUMBER	FIGURE NUMBER		ITEM NUMBER OR REF. DESIGNATION	FEDERAL STOCK NUMBER	FIGURE NUMBER		ITEM NUMBER OR REF. DESIGNATION	FEDERAL STOCK NUMBER	FIGURE NUMBER		ITEM NUMBER OR REF. DESIGNATION
	MFG CO.	FIG NO.			MFG CO.	FIG NO.			MFG CO.	FIG NO.	
REF NO.	MFG CO.	FIG NO.	ITEM NO OR REF DES.	REF NO.	MFG CO.	FIG NO.	ITEM NO OR REF DES.	REF NO.	MFG CO.	FIG NO.	ITEM NO OR REF DES.
310-0397-00	79087		A8A3A4A1L139H2	310-6325-000	79807		A8A7E5H4	334-0043-000	21537		A8A3P2H1
310-3097-00	79087		A8A3A4A1L140H2	310-6340-000	79807		A8A1MP2H3	334-0043-000	21537		A8A3P3H1
310-0397-00	79807		A8A3A4A1L141H2	310-6340-000	79807		A8A1MP2H4	334-0043-000	21537		A8A3P4H1
310-0397-00	79807		A8A3A4A1L142H1	310-6340-000	79807		A8A5E3H2	334-1290-000	13499		A8A3A4A1L125H1
310-0397-00	79807		A8A3A4A2L143H2	310-6360-000	79807		A3E1H2	334-1290-000	13499		A8A3A4A1L126H1
310-0397-00	79807		A8A3A4A2L129H2	310-6360-000	79807		A3E2H2	334-1290-000	13499		A8A3A4A1L127H1
310-0397-00	79807		A8A3A4A2L130H2	310-6360-000	79807		A3E3H2	334-1290-000	13499		A8A3A4A1L133H1
310-0397-00	79807		A8A3A4A2L131H2	310-6360-000	79807		A3E4H2	334-1290-000	13499		A6A3A4A1L134H1
310-0397-00	79807		A8A3A4A2L132H2	310-6360-000	79807		A8A5MP2H1	334-1290-000	13499		A8A3A4A1L138M1
310-0397-00	79807		A8A3A4A1L133H2	310-6360-000	79807		A6A5MP9H2	334-1290-000	13499		A8A3A4A1L139H1
310-0397-00	79807		A8A3A4A1L134H2	310-6360-000	79807		A8MP8H4	334-1290-000	13499		A8A3A4A1L140H1
310-0397-00	79807		A8A3A4A1L138H2	3100L015-1001	80294	3-23	APA3702K1	334-1290-000	13499		A8A3A4A1L141H1
310-0397-00	79807		A8A3A4A2L135H2	311-0774-000	70318		A8A7A1A2MP6	334-1290-000	13499		A8A3A4A1L142H2
310-0397-00	79087		A8A3A4A2L136H2	311-0774-000	70318		A8A7A1A2MP7	334-1290-000	13499		A8A3A4A2L128H1
310-0397-00	79087		A8A3A4A2L137H2	311-0774-000	70318		A8A7A1A2MP8	334-1290-000	13499		A8A3A4A2L129H1
310-0397-00	79807		A6A3A4A2L144H2	311-0774-000	70318		A8A7A1A2MP9	334-1290-000	13499		A8A3A4A2L130H1
310-0447-000	79807		A6A3MP3H5	324-1682-100	08664		A8A3MP12H2	334-1290-000	13499		A8A3A4A2L131H1
310-0447-000	79807		A6A3MP3H6	32442	00779		A8A3A3E1	334-1290-000	13499		A8A3A4A2L132H1
310-6320-00	79807		A6A3A4H1	32442	00779		A8A3A3E2	334-1290-000	13499		A8A3A4A2L135H1
310-6320-00	79807		A8A3E48R148H5	328-0014-000	08664		A6A4A3MP1H1	334-1290-000	13499		A8A3A4A2L136H1
310-6320-00	79807		A8A3E48R148H6	328-0014-000	08664		A8A4A4MP1H1	334-1290-000	13499		A8A3A4A2L137H1
310-6320-00	79807		A8A3E48R150H5	33C58	01939	3-16	A8A1C43	334-1290-000	13499		A8A3A4A2L143H1
310-6320-00	79807		A8A3E48R150H6	330-1194-000	45722		A8A8MP5H1	334-1290-000	13499		A8A3A4A2L144H1
310-6320-00	79807		A8A3MP16H2	330-1194-000	45722		A8A8MP5H2	335-0020-000	08664		A8A4MP24H1
310-6320-00	79807		A8A3MP17H2	330-1194-000	45722		A8A8MP5H3	335-0020-000	08664		A8A1MP24H2
310-6320-00	79807		A8A5P1H5	330-1194-000	45722		A8A8MP5H4	335-0020-000	08664		A8A4MP42H1
310-6320-00	79807		A8A5P1H6	330-1194-000	45722		A8A8MP5H5	335-0020-000	08664		A8A4MP42H2
310-6325-000	79807		A8A3P1H5	330-1194-000	45722		A8A8MP5H6	335-0020-000	08664		A8A4MP45H1
310-6325-000	79807		A8A4A15H2	330-1194-000	45722		A8A8AMP5H7	335-0020-000	08664		A8A4MP45H2
310-6325-000	79807		A8A4E37H3	330-1194-000	45722		A8A8MP5H8	335-0020-000	08664		A8A4MP46H1
310-6325-000	79807		A8A4E38H3	330-2352-000	70601		A8A5R22H1	335-0020-000	08664		A8A4MP46H2
310-6325-000	79807		A8A4E39H3	330-2352-000	70601		A8A5R3H1	340-0127-000	91314		A8A4MP92
310-6325-000	79807		A8A4E55H4	330-2352-000	70601		A8A5R4H1	340-0127-000	91314		A8A4MP93
310-6325-000	79807		A8A4E56H4	330-2352-000	70601		A8A778171H3	340-0127-000	91314		A8A4MP94
310-6325-000	79807		A8A4E577H3	330-2352-000	70601		A8A778171H4	340-0127-000	91314		A8A4MP95
310-6325-000	79807		A8A4784H3	330-2352-000	70601		A8A778173H3	340-0642-00	91314		A8A4MP61
310-6325-000	79807		A8A4784H4	330-2352-000	70601		A8A778173H4	340-0642-00	91314		A8A4AP62
310-6325-000	79807		A8A4786H2	334-0043-000	21537		A8A3P1H1	340-0642-00	91314		A8A4MP63

**SECTION IV. INDEX-FEDERAL STOCK NUMBER & REFERENCE NUMBER CROSS-REFERENCE
TO FIGURE & ITEM NUMBER (Continued)**

FEDERAL STOCK NUMBER	FIGURE NUMBER		ITEM NUMBER OR REF. DESIGNATION	FEDERAL STOCK NUMBER	FIGURE NUMBER		ITEM NUMBER OR REF. DESIGNATION	FEDERAL STOCK NUMBER	FIGURE NUMBER		ITEM NUMBER OR REF. DESIGNATION
	REF NO.	MFG CO.			FIG NO.	REF NO.			MFG CO.	FIG NO.	
340-0642-00	91314		A8A4MP64	4-48X-8 6SPLINE OVPT18-8SS7	08664		A8A4A6A7MP9H1	4040-2HDSPL	77147		A8A3E37
340-0642-00	91314		A8A4MP65					4040-2HDSPL	77147		A8A4E44
340-0642-00	91314		A8A4MP66	4-48X1-8 6SPLINE OVPT18-8SS7	08664		A8A4A6A7MP9H2	4040-2HDSPL	77147		A8A4E45
340-0642-00	91314		A8A4MP67	4-48X1-8 6SPLINE OVPT18-8SS7	08664		A8A4MP44H1	4040-2HDSPL	77147		A8A4E46
340-0642-00	91314		A8A4MP68	4JX1182023	03508		A8A7TB1Q29	4040-2HDSPL	77147		A8A4E47
340-0642-00	91314		A8A4MP69	4L4F	96881		A8A4MP9	4040-2HDSPL	77147		A8A4E48
340-0642-00	91314		A8A4MP70	4007-4H7	77147		A8A1E6	4040-2HDSPL	77147		A8A4E49
340-0642-00	91314		A8A4MP71	4007-4H7	77147		A8A3E17	4040-2HDSPL	77147		A8A4E50
340-0642-00	91314		A8A4MP72	4007-4H7	77147		A8A3E18	4040-2HDSPL	77147		A8A4E51
340-0642-00	91314		A8A4MP73	4007-4H7	77147		A8A3E19	4040-2HDSPL	77147		A8A4E52
340-0642-00	91314		A8A4MP74	4007-4H7	77147		A8A3E20	4040-2H7	77147		A8A1E2
340-0642-00	91314		A8A4MP75	4007-4H7	77147		A8A3E21	4040-2H7	77147		A8A3A4E1
340-0642-000	91314		A8A4MP76	4007-4H7	77147		A8A3E22	4040-2H7	77147		A8A3A4E2
340-0642-00	91314		A8A4MP77	4007-4H7	77147		A8A3E23	4040-2H7	77147		A8A3A4E3
340-0642-00	91314		A8A4MP78	4007-4H7	77147		A8A3E24	4040-2H7	77147		A8A3A4E4
340-0642-00	91314		A87AMP79	4007-4H7	77147		A8A3E25	4040-2H7	77147		A8A37B2E4
340-0642-00	91314		A8A4MP80	4007-4H7	77147		A8A3E26	4040-2H7	77147		A8A37B2E5
340-0642-00	91314		A8A4MP81	4007-4H7	77147		A8A3E27	4040-2H7	77147		A8A37B2E6
340149	75915		A81A4XF1	4007-4H7	77147		A8A3E28	4040-2H7	77147		A8A37B2E7
340164	75915		A8A4XF2	4007-4H7	77147		A8A3E27	4040-2H7	77147		A8A3E5
35107	00779		ASE3	4007-4H7	77147		A8A3TB1E4	4040-5HDSPL	77117		A8A2E9
36C228A3	56289	3-66	A8A4A1C139	4007-4H7	77147		A8A3TB1E5	4040-5HDSPL	77147		A8A3E38
46062	75818		A7A1E1W1	4007-4H7	77147		A8A3TB1E6	4040-5HDSPL	77147		A8A3E39
36062	75818		A7A2E1W1	4007-4H7	77147		A8A37B2E1	4040-5HDSPL	77147		A8A3E39
36109	75818		A8A3A3W1	4007-4H7	77147		A8A4E34	4040-5HDSPL	77147		A8A3E41
36665	73386	3-67	A8A472	4007-6H7	77147		A8A4E35	4040-5HDSPL	77147		A8A3E42
4-48X1-8 6 SPLINE OVPT18-8SS7	08664		A8A4A6A7MP10H1	4007-6H7	77147		A8A4E36	4040-5HDSPL	77147		A8A3E43
4-48X1-8-6 SPLINE OVPT18-8SS7	08664		A8A4A6A7MP10H2	4007-8H7 4007-8H7	77147 77147		A8A3A4A1E1 A8A3A4A1E2	4040-5HDSPL 4040-5HDSPL	77147 77147		A8A3E44 A8A4E53
4-48X1-8 6 SPLINE OVPT18-8SS7	08664		A8A4A6A7MP6H1	4007-8H7	77147		A8A4A1E3	41C92	01939		A8A4FL2C231
4-48X1-8 6 SPLINE OVPT18- 8SS7	08664		A8A4A6A7MP7H2	4007-8H4	77147		A8A3A4A2E1	41C92	01939		A8A4FL2C232
				4007-8H7	77147		A8A3A4A2E2	41C92	01939		A8A4FL2C233
4-48X1-8 6 SPLINE OVPT18-8SS7	08664		A8A4A6A7MP7H1	4007-8H7	77147		A8A3A1A2E3	4422-11-117	82142	3-37	A8A3E46L102
4-48X1-8 6 SPLINE OVPT18-8SS7	08664		A8A4A6A7MP7H2	4021	77147		A8A4E139	4422-11-117	82142		A8A4FL2L206
4-48X1-8 6 SPLINE OVPT18-8SS7	08664		A8A4A6A7MP8H1	4040-2HDSPL	77147		A8A2E6	44655		3-65	A8A4L121
4-48X1-8 6 SPLINE OVPT18-8SS7	08664		A8A4A6A7MP8H2	4040-2HDSPL	77147		A8A2E7	45-4594	04221	3-50	A8A5K1
4-48X1-8 6 SPLINE OVPT18-8SS7	08664		A5A4A6A7MP8H2	4040-2HDSPL	77147		A8A2E8	500-1065-003	13499		A8A4S102H2
								500-1065-003	13499		A8A4S2H2

**SECTION IV. INDEX-FEDERAL STOCK NUMBER & REFERENCE NUMBER CROSS-REFERENCE
TO FIGURE & ITEM NUMBER (Continued)**

FEDERAL STOCK NUMBER	FIGURE NUMBER		ITEM NUMBER OR REF. DESIGNATION	FEDERAL STOCK NUMBER	FIGURE NUMBER		ITEM NUMBER OR REF. DESIGNATION	FEDERAL STOCK NUMBER	FIGURE NUMBER		ITEM NUMBER OR REF. DESIGNATION
	MFG CO.	FIG NO.			MFG CO.	FIG NO.			MFG CO.	FIG NO.	
REF NO.	MFG CO.	FIG NO.	ITEM NO OR REF DES.	REF NO.	MFG CO.	FIG NO.	ITEM NO OR REF DES.	REF NO.	MFG CO.	FIG NO.	ITEM NO OR REF DES.
500-1065-003	13499		A8A4S3H2	5133-18C	79136		A8A4A6H11	541-8646-002	13499		A8A4A6A7A1MP2
500-2179-002	13499		A8A4A6A11MP3	5133-18C	79136		A8A4A6H12	542-1348-002	13499		A8A1Q11H2
500-2179-002	13499		A8A4A6A9MP3	5133-18C	79136		A8A4A6H13	542-1589-003	13499		A8A4H10
500-6308-001	13499		A8A4A6MP18H1	5133-18C	79136		A8A4A6H14	542-1589-003	13499		A8A4H1
500-6308-001	13499		A8A4A6MP19H1	5133-18C	79136		A8A4A6H9	542-1589-003	13499		A8A4H12
502-1515-002	13499		A8A3MP38H5	5133-25C	79136		A8A4H1	542-1589-003	13499		A8A4H7
502-1515-002	13499		A8A3MP38H6	5133-25C	79136		A8A4H2	542-1589-003	13499		A8A4H8
502-1515-002	13499		A8A3MP38H7	5133-6C	79136		A8A4H3	542-1589-003	13499		A8A4H9
502-1515-002	13499		A8A3MP38H8	5133-6C	79136		A8A4H4	542-1598-003	13499		A7A1H1
504-0726-003	13499		A8A3A4H1	5133-6C	79136		A8A4H5	542-1598-003	13499		A7A1H2
504-0730-003	13499		A8A5TB1Q3H5	5133-6C	79136		A8A4H6	542-1598-003	13499		A7A2H1
504-0730-003	13499		A8A5TB1Q3H6	522-3354-004	13499		A8A8	542-1598-003	13499		A7A2H2
504-7415-002	13499		A8A5E18	526-6052-001	13499	3-45	A8A5T2	543-5561-003	13499		A8AQ11H3
504-7577-002	13499		A8A3MP12	526-9376-000	13499	3-21	A8A2FL1	543-5656-003	13499		A8A4A6H15
504-7577-002	13499		A8A4MP22	540-9223-003	13499		A8A4A16MP3	543-5656-003	13499		A8A4A6H16
504-7577-002	13499		A8A4MP23	540-9223-003	13499		A8A4A16MP4	543-5656-003	13499		A8A4A6H17
506-5908-003	13499		A8A4MP35H1	540-9229-003	13499		A8A4A16MP5	544-2986-002	13499		A8A4A6A7MP5
506-5950-003	13499		A8A7A1A3H2	540-9229-003	13499		A8A4A16MP6	546-3043-003	13499		A8A3A4H1
506-5950-003	13499		A8A7A1A3H3	541-5179-002	13499		A8A4MP14	548-7643-002	13499		A8A8H2
506-5950-003	13499		A8A7A1A3H4	541-5179-002	13499		A8A7MP4	548-7761-002	13499		A8A3MP18
506-5950-003	13499		A8A7A1A4H2	541-5181-002	13499		A8A4MP15	548-7761-002	13499		A8A3MP19
506-5950-003	13499		A8A7A1A4H3	541-5182-002	13499		A8A4MP16	548-7761-002	13499		A8A3M20
5101-37MD	89462		A8A3H19	541-5182-002	13499		A8A4MP17	548-7761-002	13499		A8A3MP21
5101-37MD	89462		A8A3H20	541-5987-002	13499		A6A7MP15	548-7762-003	13499		A8A7MP8
5101-37MD	89462		A8A3A21	541-5987-002	13499		A8A7MP16	548-7777-003	13499		A8A3MP7
5101-37MD	89462		A8A3H22	541-5987-002	13499		A8A7MP17	548-7777-003	13499		A8A3MP8
5101-37MD	89462		A8A3H23	541-5987-002	13499		A8A7MP18	548-7779-003	13499		A8A3MP26
5133-15C	79136		A8A3H13	541-6017-002	13499		A8A4MP85	548-7782-002	13499		A8A3A4MP3
5133-15C	79136		A8A3H14	541-017-002	13499		A8A4MP85A	548-7782-002	13499		A8A3A4MP4
5133-15C	79136		A8A3H15	541-6017-002	13499		A8A4MP86	548-7783-002	13499		A8A3MP9
5133-15C	79136		A8A3H16	541-6017-002	13499		A8A4MP87	548-7786-003	13499		A8A3A4MP5
5133-15C	79136		A8A3H17	5416017-002	13499		A8A4MP88	548-7786-003	13499		A8A3A4MP6
5133-15C	79136		A8A3H18	541-6017-002	13499		A8A4MP89	548-7787-003	13499		A8A3A4MP7
5133-15C	79136		A8A4A6A7H2	541-6038-002	13499		A8A4A16MP8	548-7787-003	13499		A8A3A4MP8
5133-15C	79136		A8A4A6A7H3	541-6038-002	13499		A8A4A16MP9	548-7788-003	13499		A8A3A4MP10
5133-18C	79136		A8A4A6A7H4	541-6039-002	13499		A8A4AL6MP10	548-7788-003	13499		A8A3A4MP9
5133-18C	79136		A8A4A6A7H5	541-6039-002	13499		A8A4A16MP11	548-7789-003	13499		A8A3A4AMP12
5133-18C	79136		A8A4A6H10	541-6522-002	13499		A8A3MP31	548-7792-004	13499		A8A3E15

**SECTION IV. INDEX-FEDERAL STOCK NUMBER & REFERENCE NUMBER CROSS-REFERENCE
TO FIGURE & ITEM NUMBER (Continued)**

FEDERAL STOCK NUMBER	FIGURE NUMBER		ITEM NUMBER OR REF. DESIGNATION	FEDERAL STOCK NUMBER	FIGURE NUMBER		ITEM NUMBER OR REF. DESIGNATION	FEDERAL STOCK NUMBER	FIGURE NUMBER		ITEM NUMBER OR REF. DESIGNATION
	MFG CO.	FIG NO.			MFG CO.	FIG NO.			MFG CO.	FIG NO.	
REF NO.	MFG CO.	FIG NO.	ITEM NO OR REF DES.	REF NO.	MFG CO.	FIG NO.	ITEM NO OR REF DES.	REF NO.	MFG CO.	FIG NO.	ITEM NO OR REF DES.
548-7793-004	13499	3-33	A8A3A4A1	548-7835-002	13499		A8A3A12S8E1	548-9319-002	13499		A8A4MP56
548-7794-005	13499	3-9	A8A3A4	548-7835-002	13499		A8A3A9A2S2E1	548-9319-002	13499		A8A4MP57
548-7795-005	13499	3-33	A8A3A4A2	548-7835-003	13499		A8A3A9A3S3E1	548-9308-003	13499		A8A9
548-7797-004	13499	3-41	A8A3L145	548-7839-003	13499		A8A3A10S4E2	549-1544-003	13499		A8A6MP2
548-7799-005	13499	3-33	A8A3A4E6	548-7339-003	13499		A8A3A11S5E2	549-1545-003	13499		A8A6MP3
548-7800-002	13499		A8A3A4A1E4	548-7839-003	13499		A8A3A12S8E2	549-1549-003	13499		A8A6MP1
548-7800-002	13499		A8A3A4A1E5	548-7839-003	13499		A8A3A9A1S1E1	549-1551-003	13499	3-52	A8A6E1TB1
518-7800-002	13499		A8A3A4A1E6	548-7839-003	13499		A8A3A9A2S2E2	549-1552-004	13499	3-13	A8A6A1
548-7800-002	13499		A8A3A4A1E7	548-7839-003	13499		A8A3A9A3S3E2	549-1553-004	13499	3-12	A8A6E1
548-7800-002	13499		A8A3A4A1E8	548-7858-003	13499		A8A7E7A2E1	549-1555-005	13499	3-53	A8A6A1A1
548-7800-002	13499		A8A3A4A2E4	548-7858-003	13499		A8A7E7A2E2	549-1680-004	13499	3-12	A6A6E2
518-7800-002	13499		A8A3A4A2E5	548-7870-004	13499		A8A3A4MP1	549-1682-004	13499	3-52	A8A6E2TB1
548-7800-002	13499		A8A3A4A2E6	548-7872-004	13499		A8A3A4MP2	549-5641-000	13499		A8AW11
548-7800-002	13499		A8A3A4A2E7	548-7882-004	13499		A8A3MP25	549-5642-002	13499		A8A1Q11H1
518-7800-002	13499		A8A3A4A2E8	548-7886-004	13499		A8A3A1	549-5643-002	13499		A8A3A13MP1
548-7802-004	13499	3-34	A8A3A4E7	548-7897-002	13499		A8A8MP2	549-5643-002	13499		A8A7E5MP3
548-7805-004	13499	3-31	A8A3A4A1L125	548-7908-002	13499		A8A4MP58	549-5650-003	13499	3-17	A8A1E1E1
548-7805-004	13499	3-32	A8A3A4A2L141	548-7908-002	13499		A8A4MP59	549-5651-004	13499	3-6	A8A1E2
548-7806-004	13499	3-32	A8A3A4A2L143	548-7909-002	13499		A8A4MP51	549-5653-004	13499	3-18	A8A1E2E1
548-7807-004	13499	3-31	A8A3A4A1L126	548-7909-002	13499		A8A4MP52	549-5654-004	13499	3-6	A8A1E1
548-7807-004	13499	3-31	A8A3A4A1L142	548-7910-002	13499		A8A4MP38	549-5655-004	13499	3-6	A8A1E3
548-7808-004	13499	3-31	A8A3A4A1L127	548-7910-002	13499		A8A4MP39	549-5657-004	13499	3-19	A8A1E3E1
548-7308-004	13499	3-31	A8A3A4A1L133	548-7911-002	13499		A8A4E20	549-5659-005	13499		A8A1MP1
548-7808-004	13499	3-31	A8A3A4A1L134	548-7911-002	13499		A8A4E21	549-5660-002	13499	3-21	A8A2MP3
548-7808-004	13499	3-32	A8A3A4A2L128	548-7912-004	13499		A8A3M24	549-5678-003	13499	3-20	A8A2E2
548-7808-004	13499	3-32	A8A3A4A2L129	548-7975-002	13499		A8A4J2H5	549-5680-003	13499	3-20	A8A2E2E1
548-7808-004	13499	3-32	A8A3A4A2L130	548-7975-002	13499		A8A4J2H6	549-5682-003	13499	3-21	A8A2E3E1
548-7808-004	13499	3-32	A8A3A4A2L131	548-7975-002	13499		A8A4J3H5	549-5684-003	13499	3-21	A8A2ELE1
548-7808-004	13499	3-32	A8A3A4A2L132	548-7975-002	13499		A8A4J3H6	549-5686-003	13499		A8A2E5E1
548-7809-000	13499	3-31	A8A3A4A1L141	548-7975-002	13499		A8ALJ4H5	589-868-0000	13499	3-20	A8A2E1
548-7810-004	13499	3-11	A8A3A4A1L140	558-7975-002	13499		A8A4J4H6	549-5690-000	13499		A8A2E1E1
548-7811-004	13499	3-31	A8A3A4A1L139	548-7975-002	13499		A8A4J9H5	549-5691-004	13499	3-21	A8A2E3
548-7812-004	13499	3-31	A8A3A4A1L138	548-7975-002	13499		A8A4J9H6	549-5692-004	13499	3-21	A8A2E3
548-7813-004	13499	3-32	A8A3A4A2L137	548-7976-003	13499		A8A4H5	549-5693-004	13499	3-21	A8A2E5
548-7814-004	13499	3-32	A8A3A4A2L136	548-9095-002	13499		A4A1	549-5703-005	13499		A8A1MP2
548-7815-004	13499	3-32	A8A3A4A2L135	548-9097-003	13499	1-1	A4A1MP1	549-5709-002	13499		A8A1E4
548-7835-002	13499		A8A3A1054E1	548-9098-003	13499		A5E2	549-5709-002	13499		A8A3E16
548-7835-002	13499		A8A3A1155E1	548-9101-004	13499	1-7	A4A2	549-5709-002	13499		A8A5E4

**SECTION IV. INDEX-FEDERAL STOCK NUMBER & REFERENCE NUMBER CROSS-REFERENCE
TO FIGURE & ITEM NUMBER (Continued)**

FEDERAL STOCK NUMBER	FIGURE NUMBER		ITEM NUMBER OR REF. DESIGNATION	FEDERAL STOCK NUMBER	FIGURE NUMBER		ITEM NUMBER OR REF. DESIGNATION	FEDERAL STOCK NUMBER	FIGURE NUMBER		ITEM NUMBER OR REF. DESIGNATION
	MFG CO.	FIG NO.			MFG CO.	FIG NO.			MFG CO.	FIG NO.	
REF NO.	MFG CO.	FIG NO.	ITEM NO OR REF DES.	REF NO.	MFG CO.	FIG NO.	ITEM NO OR REF DES.	REF NO.	MFG CO.	FIG NO.	ITEM NO OR REF DES.
549-5709-002	13499		A8A7E8	549-5744-002	13499		A8A7E5MP5	549-5813-003	13499		A8A5M9
549-5710-002	13499		A8A7MP13	549-5746-002	13499		A8A7E5E2	549-5815-003	13499		A8A5MP3
549-5710-002	13499		A8A7MP14	549-5746-002	13499		A8A7E5E3	549-5823-003	13499		A8A8E2
549-5711-002	13499		A8A7MP10	549-5748-002	13499	3-58	A8A7E5L19	549-5825-003	13499	3-48	A6A5E2EH
549-5717-002	13499		A8A7A2	549-5749-002	13499		A8A7A1A2MP3	549-5827-003	13499	3-45	A8A5E3
549-5718-002	13499		A8A7A2MP2	549-5749-002	13499		A8A7A1A2MP4	549-5829-003	13499	3-49	A8A5E3E
549-5719-002	13499		A8A7A2A1	549-5750-002	13499		A8A7A1A2MP5	549-5831-004	13499	3-11	A8A5E1
549-5719-002	13499		A8A7A3A1	549-5751-002	13499		A8A7A1A2MP1	549-5833-004	13499	3-47	A8A5E1E1
549-5720-002	13499		A8A3A8A1MP2	549-5751-002	13499		A8A7A1A2MP2	549-5835-005	13499		A8A5MP1
549-5720-002	13499		A8A7A2A1MP2	549-5752-002	13499		A8A7W1	549-5836-002	13499		A8A5MP4
549-5720-002	13499		A8A7A3A1MP2	549-5755-003	13499		A8A77P9	549-5836-002	13499		A8A5MP5
549-5721-002	13499		A8A3A2M3	549-5760-003	13499		A8A7A2A1MP1	549-5838-000	13499		A8A3W1
549-5721-002	13499		A8A3A8A1MP3	549-5760-003	13499		A8A7A3A1MP1	549-5843-002	13499		A8A7E7A2MP1
549-5721-002	13499		A8A7A2A1MP3	549-5761-003	13499		A8A7A1	549-5843-002	13499		A8A7E7A2MP2
549-5721-002	13499		A8A73A3	549-5762-003	13499		A8A7A1A4MP3	549-5846-002	13499		A8A3A8MP2
549-5722-002	13499		A8A7A3	549-5764-003	13499	3-60	A8A7E7A1E8	549-5850-002	13499		A8A3A9MP1
549-5723-002	13499		A8A7A3M2	549-5767-003	13499		A8A7MP12	549-5850-002	13499		A8A3A9MP2
549-5724-002	13499		A6A7A1A3	549-5771-003	13499	3-55	A8A7E2E2	549-5850-002	13499		A8A3A99 3
549-5725-002	13499		A8A7A1A3W3	549-5775-004	13499		A8A7MP11	549-5850-002	13499		A8A3A9MP4
549-5726-002	13499		A8A77AA31P1	549-5776-004	13499	3-4	A8A7E7	549-5851-002	13499		A8A3A9MP5
549-5727-002	13499		A8A7AL3A1	549-5777-004	13499	3-60	A8A7E7A1	549-5851-002	13499		A8A3A9MP6
549-5728-002	13499		A8A7A1A3A1MP2	549-5778-004	13499	3-60	A8A7E7A2	549-5851-002	13499		A8A3A9MP7
549-5729-002	13499		A8A7A1A3A1MP1	549-578-0004	13499	3-60	A8A7E7A2E1	549-5851-002	13499		A8A39MA9P8
549-5730-002	13499		A8A71A1A4	549-5783-004	13499	3-15	A8A7E5	549-5853-002	13499		A8A3A2MP
549-5731-002	13499		A8A7A1A4W1	549-5785-004	13499	3-58	A8A7E5E1	549-5854-002	13499		A6A3A8A1MP1
549-5732-002	13499		A8A7A1A4MP2	549-5788-000	13499	3-14	A8A7E4	549-5857-002	13499		A8A3A7MP5
549-5733-002	13499		A8A7A1A1	549-5790-004	13499	3-57	A8A7E4E1	549-5858-002	13499		A8A3A7MP6
549-5734-002	13499		A8A7A1A1MP2	549-5794-004	13499	3-14	A8A7E2	549-5859-002	13499		A8A3M27
549-5735-002	13499		A8A7E7A2MP10	549-5796-004	13499	3-15	A8A7E1	549-5859-002	13499		A8A3MP28
549-5735-002	13499		A8A7E7A2MP9	549-5798-004	13499	3-54	A8A7E1E1	549-5860-002	13499		A8A3MP5
549-5737-002	13499		A8A7E7A2MP3	549-5801-004	13499	3-14	A8A7E6	549-5860-002	13499		A8A3MP6
549-5735-002	13499		A8A7E7A2MP4	549-5803-004	13499	3-59	A8A7E6E1	549-5861-002	13499		A8A3A7MP3
549-5737-002	13499		A8A7E7A2MP5	549-5806-004	13499		A8A7A1A2MP10	549-5861-002	13499		A8A3A7MP4
549-5737-002	13499		A8A71E7A2MP6	549-5807-004	13499		A8A7A1A2	549-5862-002	13499		A8A3MP13
549-5742-002	13499		A8A7E5MP1	549-5809-005	13499		A8A7A1MP5	549-5862-002	13499		A8A3MP14
549-5742-002	13499		A8A7E5MP2	549-5810-000	13499		A8A5W1	549-5863-002	13499		A8A3MP39
549-5743-002	13499		A8A7E5E4	549-5811-002	13499		A8A5MP7	549-5863-002	13499		A8A3MP40
549-5744-002	13499		A8A7E5MP4	549-5811-002	13499		A8A5MP8	549-5864-002	13499		A8A3MP30

**SECTION IV. INDEX-FEDERAL STOCK NUMBER & REFERENCE NUMBER CROSS-REFERENCE
TO FIGURE & ITEM NUMBER (Continued)**

FEDERAL STOCK NUMBER	FIGURE NUMBER		ITEM NUMBER OR REF. DESIGNATION	FEDERAL STOCK NUMBER	FIGURE NUMBER		ITEM NUMBER OR REF. DESIGNATION	FEDERAL STOCK NUMBER	FIGURE NUMBER		ITEM NUMBER OR REF. DESIGNATION
	MFG CO.	FIG NO.			MFG CO.	FIG NO.			MFG CO.	FIG NO.	
REF NO.	MFG CO.	FIG NO.	ITEM NO OR REF DES.	REF NO.	MFG CO.	FIG NO.	ITEM NO OR REF DES.	REF NO.	MFG CO.	FIG NO.	ITEM NO OR REF DES.
549-5865-002	13499		A8A3MP29	549-5931-003	13499	3-30	A8A3A11L62	549-5999-004	13499	3-39	A8A3E48E1
549-5866-002	13499		A8A3A5MP5	549-5931-003	13499	3-35	A8A3A12L79	549-6000-004	13499	3-9	A8A3E48
549-5866-002	13499		A8A3A6MP7	549-5931-003	13499	3-27	A8A3A9A2L7	549-6002-003	13499	3-39	A8A3E4871
549-5868-002	13499		A8A3MP36	549-5931-003	13499	3-27	A8A3A9A3L32	549-6006-000	13499		A8A4A6
549-5868-002	13499		A8A3MP37	549-5932-003	13499	3-35	A8A3A12L80	549-6010-002	13499		A8A4A6A7MP1
549-5869-002	13499		A8A3MP1	549-5933-003	13499	3-29	A8A3A10L48	549-6011-002	13499		A8A4A6A7MP2
549-5869-002	13499		A8A3MP2	549-5933-003	13499	3-30	A8A3A11L63	549-6012-002	13499		A8A4A6A7MP3
549-5870-002	13499		A8A3A7	549-5933-003	13499	3-35	A8A3A12L1	549-6013-002	13499		A8A4A6A7MP4
549-5878-002	13499		A8A3A5MP3	549-5933-003	13499	3-27	A8A3A9A2L18	549-6014-002	13499		A8A4A6A7MP15
549-5878-002	13499		A8A3A6MP3	549-5933-003	13499	3-28	A8A3A9A3L33	549-6015-002	13499		A8A4A6A7A1MP5
549-5881-002	13499		A8A3A2	549-5935-003	13499	3-29	A8A3A10L19	549-6016-002	13499		A8A4A6A7MP16
549-5882-002	13499		A8A3A8A1	549-5935-003	13499		A8A3A11L64	549-6017-002	13499		A8A4A6A7MP17
549-5885-002	13499	3-36	A8A3A13L103	549-5935-003	13499	3-27	A8A3A9A2L19	549-6018-002	13499		A8A4A6A7A3MP3
549-5886-002	13499		A8A3MP32	549-5935-003	13499	3-28	A8A3A9A3L34	549-6018-002	13499		A8A4A6A7A4MP3
549-5886-002	13499		A8A3MP33	549-5936-003	13499	3-29	A8A3A10L50	549-6021-002	13499		A8A4A6MP22
549-5886-002	13499		A8A3MP3	549-5936-003	13499	3-30	A8A3A11L65	549-6021-002	13499		A8A4A6M(P23
549-5836-002	13499		A8A3MP35	549-5936-003	13499	3-27	A8A3A9A2L20	549-6021-002	13499		A8A4A6[P24
549-5887-002	13499		A8A3A8	549-5936-003	13499	3-28	A8A3A9A3L35	549-6021-002	13499		A8A4A6MP25
549-5889-003	13499	3-29	A8A3A10E6	549-5937-003	13499	3-29	A8A3A10L51	549-6021-002	13499		A8A4A6MP26
549-5889-003	13499	3-30	A8A3A3L8	549-5937-003	13499	3-30	A8A3A11L66	549-6021-002	13499		A8A4A6KP27
549-5889-003	13499	3-35	A8A3A12R12	549-5937-003	13499	3-27	A8A3A9A2L21	549-6022-002	13499		A8A4A6A7A2MP1
549-5889-003	13499	3-25	A8A3A9A22	549-5937-003	13499	3-28	A8A3A9A3L36	549-6023-002	13499		A8A4A6A72P2
549-5889-003	13499	3-28	A8A3A9A3F4	549-5950-004	13499	3-29	A8A3A10S4	549-6024-002	13499		A8A4A6A7A2
549-5890-003	13499	3-29	A8A3A0Z5	549-5950-004	13499	3-30	A8A3A11S5	549-6025-002	13499		A8A4A6MP51
549-5890-003	131499	3-30	A8A3A11E7	549-5950-004	13499	3-35	A8A3A12S8	549-6025-002	13499		A8A4A6MP51H2
549-5890-003	13499	3-35	A8A3A12E11	549-5950-004	13499	3-27	A8A3A9A2S2	549-6025-002	13499		A8A4A6MP52
549-5890-003	13499	3-24	A8A3A9A2	549-5950-004	13499		A8A3A9A3S3	549-6028-002	13499		A8A4A6HP53
549-5890-003	13499	3-28	A8A3A9A3E3	549-5951-014	13499		A8A3A3S9	549-6028-002	13499		A8A4A6MP54
549-5893-003	13499		A8A3MP38	549-5952-000	13499		A8A3A5MP4	549-6029-0C2	13499		A8A4A6AMP1
549-5908-003	13499	3-10	A8A3A13	549-5953-004	13499		A8A3A6M6	549-6029-002	13499		A8A4A6A2MP1
549-5921-003	13499		A8A3A5	549-5959-004	13499	3-10	A8A3A9	549-6030-002	13499		A8A4A6MP38
549-5922-003	13499		A8A3A6	549-5972-002	13499	3-41	A8A3L1	549-6033-002	13499		A8A4A6A4MP2
549-5924-003	13499	3-24	A8A3A9A1	549-5972-002	13499	3-41	A8A3L2	549-6034-002	13499		A8A4A6MP37
549-5925-003	13499	3-24	A8A39A.2	549-5972-002	13499	3-41	A8A3L3	549-6035-002	13499		A8A4A6A6MP1
549-5926-003	13499	3-24	A8A3A9A3	549-5982-003	13499	3-37	A8A3E46E1	549-6036-002	13499		A8A4A6MP40
549-5927-003	13499	3-10	A8A3A10	549-5984-003	13499	3-10	A8A3E46	549-6037-002	13499		A8A4A6MP41
549-5928-003	13499	3-10	A8A3A11	549-5995-004	13499	3-38	A8A3E47E1	549-6038-002	13499		A8A4A6A4MP1
549-5931-003	13499	3-29	A8A3A10L47	549-5996-004	13499	3-9	A8A3E47				

**SECTION IV. INDEX-FEDERAL STOCK NUMBER & REFERENCE NUMBER CROSS-REFERENCE
TO FIGURE & ITEM NUMBER (Continued)**

FEDERAL STOCK NUMBER	FIGURE NUMBER		ITEM NUMBER OR REF. DESIGNATION	FEDERAL STOCK NUMBER	FIGURE NUMBER		ITEM NUMBER OR REF. DESIGNATION	FEDERAL STOCK NUMBER	FIGURE NUMBER		ITEM NUMBER OR REF. DESIGNATION
	MFG CO.	FIG NO.			MFG CO.	FIG NO.			MFG CO.	FIG NO.	
REF NO.	MFG CO.	FIG NO.	ITEM NO OR REF DES.	REF NO.	MFG CO.	FIG NO.	ITEM NO OR REF DES.	REF NO.	MFG CO.	FIG NO.	ITEM NO OR REF DES.
549-6039-002	13499		A8A4A6A6	549-6074-002	13499		A8A4J5H5	549-6102-002	13499		A8A4MP91
549-6040-002	13499		A8A4A6A5MP1	549-6074-002	13499		A8A4J6H5	549-6103-002	13499		A8A4A6E1
549-6041-002	13499		A8A4A6A2MP6	549-6074-002	13499		A8A4J6H6	549-6104-002	13499		A8A4A6E2
549-6042-002	13499		A8A4A6A1MP2	549-6074-002	13499		A8A4J7H4	549-6104-002	13499		A8A4A6A3
549-6043-002	13499		A8A4A6A2MP2	549-6074-002	13499		A8A4J7H5	549-6105-002	13499		A8A4A5
549-6044-002	13499		A8A4A6MP63	549-6074-002	13499		A8A4J8H5	549-6109-003	13499		A8A4MP26
549-6045-002	13499		A8A4A6A1	549-6074-002	13499		A8A4J8H6	549-6113-003	13499		A8A4A6A7A1
549-6046-002	13499		A8A4A6A5	549-6075-002	13499		A8A4A6A9MP1	549-6114-003	13499		A8A4A6E5
549-6047-002	13499		A8A4A6A2	549-6076-002	13499		A8A4A6MP55	549-6115-004	13499		A8A4MP19
549-6047-002	13499		A8A4A6MP61	549-6076-002	13499		A8A4A6MP56	549-6116-004	13499		A8A4A6A7
549-6049-002	13499		A8A4A6S8	549-6076-002	13499		A8A4A6MP57	549-6117-004	13499		A8A4A6AMP1
549-6049-002	13499		A8A4A6MP29	549-6077-002	13499		A8A4A6MP48	549-6118-004	13499		A8A4A6A12
549-6050-002	13499		A8A4A6	549-6077-002	13499		A8A4A6MP49	549-6121-002	13499		A8A4A6MP36
549-6051-002	13499		A8A4A6A7MP10	549-6077-002	13499		A8A4A6MP50	549-6122-005	13499		A8A4A6A8
549-6051-002	13499		A8A4A6A7MP6	549-6078-002	13499		A8A4A6MP44	549-6124-002	13499		A8A4MP45
549-6051-002	13499		A8A4A6A7MP7	549-6079-002	13499		A8A4A6MP45	549-6126-002	13499		A8A4A15
549-6051-002	13499		A8A4A6A7MP8	549-6080-002	13499		A8A4A6A9	549-6129-002	13499		A8A4MP36
549-6051-002	13499		A8A4A6A7MP9	549-6081-002	13499		A8A4A6MP58	549-6135-002	13499		A8A4MP54
549-6052-002	13499		A8A4A6MP39	549-6081-002	13499		A8A4A6MP59	549-6136-002	13499		A8A4MP30
549-6053-002	13499		A8A4A6A7MP14	549-6081-002	13499		A8A4A6MP60	549-6137-002	13499		A8A4MP24
549-6054-002	13499		A8A4A6MP64	519-6082-002	13499		A8A4A6A10	549-6138-002	13499		A8A4E55
549-6055-002	13499		A8A4A6A4	549-6085-002	13499		A8A4A6A10MP1	549-6138-002	13499		A8A4E56
549-6056-002	13499		A8A4A6A8MP4	549-6085-002	13499		A8A4A6A11MP1	549-6138-002	13499		A8A4E57
549-6056-002	13499		A8A4A6A8MP5	549-6086-002	13499		A8A4A6A11	549-6139-002	13499		A8A4A2MP1
549-6056-002	13499		A8A4A6A8MP6	549-6087-002	13499		A8A4A6MP46	549-6139-002	13499		A8A4A2MP2
549-6058-002	13499		A8A4A6A7P111	549-6087-002	13499		A8A4A6MP47	549-6140-002	13499		A8A4A2MP3
549-6060-002	13499		A8A4A6MP42	549-6089-002	13499		A8A4A6MP18	549-6141-002	13499		A8A4A2
549-6061-002	13499		A8A4A6A8MP7	549-6089-002	13499		A8A4A6MP19	549-6142-002	13499		A8A4E22
549-6065-002	13499		A8A4A6MP62	549-6090-002	13499		A8A4A6MP30	549-6142-002	13499		A8A4E23
549-6066-002	13499		A8A4A6MP63	549-6090-002	13499		A8A4A6P31	549-6143-002	13499		A8A4MP40
549-6070-002	13499		A8A4A6A12MP2	549-6091-002	13499		A8A4A6MP35	549-6143-002	13499		A8A4MP41
549-6074-002	13499		A8A4J10H5	549-6092-002	13499		A8A4A6A3MP1	549-6144-002	13499		A8A4MP46
549-6074-002	13499		A8A4J10H6	549-6093-002	13499		A8A4A5MP1	549-6145-002	13499		A8A4L110H2
549-6074-002	13499		A8A4J10H5	549-6094-002	13499		A8A4A8AMP3	549-6145-002	13499		A8A4L111H2
549-6074-002	13499		A8A4J10H6	549-6094-002	13499		A8A4A6A3MP3	549-6148-002	13499		A8A4E14
549-6074-02	13499		A8A4J11H5	549-6100-002	13499		A8A4A6MP20	549-6148-002	13499		A8A4E15
549-6074-002	13499		A8A4J11H6	549-6101-002	13499		A8A4A6MP21	549-6148-002	13499		A8A4E16
549-6074-002	13499		A8A4J5H4	549-6102-002	13499		A8A4MP90	549-6148-002	13499		A8A4E17

**SECTION IV. INDEX-FEDERAL STOCK NUMBER & REFERENCE NUMBER CROSS-REFERENCE
TO FIGURE & ITEM NUMBER (Continued)**

FEDERAL STOCK NUMBER	FIGURE NUMBER		ITEM NUMBER OR REF. DESIGNATION	FEDERAL STOCK NUMBER	FIGURE NUMBER		ITEM NUMBER OR REF. DESIGNATION	FEDERAL STOCK NUMBER	FIGURE NUMBER		ITEM NUMBER OR REF. DESIGNATION
	REF NO.	MFG CO.			FIG NO.	REF NO.			MFG CO.	FIG NO.	
549-6148-002	13499		A8A4E18	549-6163-002	13499		A8A4L12E7	549-6221-003	13499		A8A4AHP1
549-6148-002	13499		A8A4E19	549-6164-002	13499		A8A4E29	549-6223-003	13499		A8A4A16E1
549-6149-002	13499		A8A4MP84	549-6164-002	13499		A8A4E30	549-6224-002	13499		A8A4A6A7A3KP1
549-6152-002	13499		A8A4L109MP8	549-6164-002	13499		A8A4E31	549-6224-002	13499		A8A4A6A7A4MP1
549-6153-002	13499		A8A4L109E1	549-6164-002	13499		A8A4E32	549-6225-002	13499		A8A4A6A7A3
549-6153-002	13499		A8A4L109E2	549-6167-002	13499		A8A4MP10	549-6225-002	13499		A8A4A6A7A4
549-6153-002	13499		A8A4L110E1	549-6167-002	13499		A8A4MP11	549-6227-000	13499	3-67	A8A4w1
549-6153-002	13499		A8A4L110E2	549-6171-002	13499		A8A4L109A1	549-6229-003	13499		A8A4A7
549-6153-002	13499		A8A4L111E1	549-6172-002	13499		A8A4L111MP1	549-6230-004	13499		A8A4A1
549-6153-002	13499		A8A4L111E2	549-6173-002	13499		A8A4E24	549-6231-004	13499		A8A4MP18
549-6153-002	13499		A8A4L112E1	549-6174-002	13499		A8A4E131	549-6232-004	13499		A8A4A16
549-6153-002	13499		A8A4L112E2	549-6175-002	13499		A8A4L112MP1	549-6234-003	13499		A8A4MP12
549-6154-002	13499		A8A4L109E4	549-6176-002	13499		A8A4L110MP1	549-6242-002	13499		A2MP4
549-6154-002	13499		A8A4L109E5	549-6177-002	13499		A8A4E25	549-6244-002	13499		A2J1H2
549-6154-002	13499		A8A4L110E4	549-6177-002	13499		A8A4E26	549-6244-002	13499		A2J2H3
549-6154-002	13499		A8A4L110E5	549-6177-002	13499		A8A4E27	549-6245-002	13499		A2J1
549-6154-002	13499		A8A4L111E4	549-6177-002	13499		A8A4E28	549-6245-002	13499		A2J2
549-6154-002	13499		A8A4LL11E5	549-6178-002	13499		A8A4L109MP4	549-6246-002	13499		A2ALP1H1
549-6154-002	13499		A8A4L112E4	549-6178-002	13499		A8A4L112MP2	549-6246-002	13499		A2A12MH1
549-6154-002	13499		A8A4L112E5	549-6185-002	13499		A8A4MP34	549-6247-002	13499		A2A1
549-6155-002	13499		A8A4MP27	549-6189-002	13499		A8A4MP42	549-6247-002	13499		A2A2
549-6156-002	13499		A8A4MP32	549-6190-002	13499		A8A4MP44	549-6250-003	13499		A2MP2
549-6156-002	13499		A8A4MP33	549-6191-002	13499		A8A4A7MP1	549-6252-003	13499		A2P81
549-6157-002	13499		A8A4L109A1MP1	549-6193-002	13499		A8A4A7A1E1	549-6254-004	13499		A8A4AA6A7A1M
549-6158-002	13499		A8A4L111MP2	549-6194-002	13499		A8A4A7A1	549-6277-000	13499		A6
549-6159-002	13499		A8A4L1110MP3	549-6195-002	13499		A8A4MP60	549-6278-002	13499		A6A1MP1
549-6159-002	13499		A8A4L11MP6	549-6196-002	13499		A8A4MP35	549-6278-002	13499		A6A2MP1
549-6160-002	13499		A8A4L109MP7	549-6197-002	13499		A8A4A16MP7	549-6279-002	13499		A6MP7
549-6160-002	13499		A8A4L112MP5	549-6198-002	13499		A8A4A116L104-R110	549-6280-002	13499		A6MP5
549-6162-002	13499		A8A4L109A1MP3	549-6205-003	13499		A864A15E1	549-6280-002	13499		A6MP6
549-6162-002	13499		A8A4L111MP4	549-6210-003	13499	3-67	A8A4TB4	549-6281-002	13499		A6A1
549-6163-002	13499		A8A4L109E6	549-6211-003	13499		A8A4E33	549-6281-002	13499		A6A2
549-6163-002	13499		A8A4L109E7	549-6212-003	13499	3-64	A8A4L111	549-6282-002	13499		A6MP10
549-6163-002	13499		AA4L1110E6	549-6213-003	13499	3-64	A8A4L110	549-6287-002	13499		A6A3MP11
549-6163-002	13499		A8A4L110E7	549-6214-003	13499	3-65	A8A4L112	549-6289-003	13499		A6A3MP2
549-6163-002	13499		A8A4L111E6	549-6215-003	13499	3-65	A8A4L109	549-6390-003	13499		A85ATB1E1
549-6163-002	13499		A8A4L111E7	549-6217-003	13499		A8A4MP55	549-6391-003	13499	3-67	A8A4TB1
549-6163-002	13499		A8A4L112E6	549-6219-003	13499		A8A4A4A1	549-6292-003	13499		A6A4

**SECTION IV. INDEX-FEDERAL STOCK NUMBER & REFERENCE NUMBER CROSS-REFERENCE
TO FIGURE & ITEM NUMBER (Continued)**

FEDERAL STOCK NUMBER	FIGURE NUMBER		ITEM NUMBER OR REF. DESIGNATION	FEDERAL STOCK NUMBER	FIGURE NUMBER		ITEM NUMBER OR REF. DESIGNATION	FEDERAL STOCK NUMBER	FIGURE NUMBER		ITEM NUMBER OR REF. DESIGNATION
	REF NO.	MFG CO.			FIG NO.	REF NO.			MFG CO.	FIG NO.	
549-6293-004	13499		A6A3	549-6486-002	13499		A7A2MP3	553-5032-003	13499		A8A3H9
549-6394-003	13499		A8A4TB6E1	549-6486-002	13499		A7A2MP4	553-6279-002	13499		A8A4FL2E1
549-6395-003	13499	3-67	A8A4TB6	549-6487-002	13499		A7ALMP5	553-6300-004	13499		A8A4FL2E2
549-6398-002	13499		A8A8H4	549-6487-002	13499		A7A1MP6	553-6325-002	13499	3-67	A8A4L4
549-6404-004	13499	3-20	A8A2A1	549-6487-002	13499		A7A2AP5	553-6329-003	13499		A8A4A6A8MP3
549-6406-004	13499	3-11	A8A5A1	549-6487-002	13499		A7A2MP6	553-6330-004	13499	3-67	A8A4FL2
549-6411-003	13499		A8A2MP2	549-6489-002	13499		A3P1H1	553-9271-003	13499		A8A4MP13
549-6412-003	13499		A8A2MP1	549-6490-002	13499		A3MP2	553-9312-003	13499	3-56	A8A7TB171
549-6475-002	13499		A7A1A1	549-6491-002	13499		A3MP3	553-9312-003	13499	3-56	A8A7TB173
549-6475-002	13499		A7A1A2	549-6493-003	13499		A3MP1	553-9313-003	13499	3-56	A8A7TB172
549-6475-002	13499		A7A2A1	549-6494-003	13499		A7A1	553-9313-003	13499	3-56	A8A7TB174
549-6475-002	13499		A7A2A2	549-6494-003	13499		A7A2	553-9315-004	13499	3-56	A8A7TB1E1
549-6476-002	13499		A7A1A1MP2	549-6495-004	13499	1-7	A7MP1	553-9316-004	13499	3-15	A8A7TB1
549-6476-002	13499		A7A1A2MP2	549-6521-003	13499		A8A3TB2	553-9321-002	13499		A8A3E8
549-6476-002	13499		A7A2A1MP2	549-6522-003	13499	3-10	A8A3TB1	553-9321-002	13499		A8A3E9
549-6476-002	13499		A7A2A2MP2	549-6523-003	13499		A8A3E7	553-9357-002	13499		A8A7A1A1MP1
549-6477-002	13499		A7A1E1	549-6525-003	13499		A8A3MP15	553-9716-003	13499		A8A5TB1MP1
549-6477-002	13499		A7A2E1	549-6527-004	13499	3-22	A8A3TB1E1	553-9717-004	13499	3-50	A8A5TB1
549-6478-002	13499		A7A1MP7	549-6529-004	13499	3-23	A8A3TB2E1	553-9731-002	13499		A8A4MP43
549-6478-002	13499		A7A2MP7	549-6598-002	13499		A8A3A3	553-9732-002	13499		A8A4A6A13H1
549-6479-002	13499		A7A1MP8	549-6601-003	13499		A8A3MP26	553-9735-002	13499		A8A4A6A13MP4
549-6479-002	13499		A7A2MP8	549-6644-002	13499		A8A4MP31	553-9736-002	13499		A8A4A6A13MP3
549-6480-002	13499		A7A1A1MP3	549-6654-002	13499		A8MP1	553-9737-003	13499		A8A4A6A13
549-6480-002	13499		A7A1A2MP3	549-6656-003	13499		A8MP8	553-9748-002	13499		A8A3MP16
549-6480-002	13499		A7A2AMP3	549-6658-00004	13499		A8A8MP5	553-9748-002	13499		A8A3MP17
549-6480-002	13499		A7A2A2MP3	553-2413-003	13499		A8A4A16MP2	553-9750-003	13499	3-67	A8A4TB8
549-6482-002	13499		A7A1MP1	553-5002-003	13499		A8A8H2	553-9750-004	13499	3-67	A8A4TB9
549-6482-002	13499		A7A1362	553-5004-003	13499		A8A8H4	553-9750-005	13499	3-67	A8A4TB1
549-6482-002	13499		A7A2MP1	553-5029-003	13499		A8A4MP43H1	553-9773-002	13499		A8A4MP53
549-6482-002	13499		A7A2MP2	553-5032-003	13499		A8A3H10	553-9786-003	13499		A8A3A2MP2
549-6483-002	13499		A7A2MP9	553-5032-003	13499		A8A3H11	553-9806-002	13499		A6A1A1MP1
549-6483-002	13499		A7A2MP9	553-5032-003	13499		A8A3H12	553-9806-002	13499		A6A2A1MP1
549-6484-002	13499		A7A1MP10	553-5032-003	13499		A8A3H13	553-9806-002	13499		A6A3A2MP1
549-6484-002	13499		A7A1MP11	553-5032-003	13499		A8A3H14	553-9806-002	13499		A6A3A2MP1
549-6484-002	13499		A7A2MP10	553-5032-003	13499		A8A3H15	553-9807-002	13499		A6A3A1MP2
549-6484-002	13499		A7A2MP11	553-5032-003	13499		A8A3H16	553-9807-002	13499		A6A3A2MP2
549-6486-002	13499		A7A1MP3	553-5032-003	13499		A8A3H17	553-9808-002	13499		A6A1A1MP2
549-6486-002	13499		A7A1MP4	553-5032-003	13499		A8A3H18	553-9808-002	13499		A6A2A1MP2

**SECTION IV. INDEX-FEDERAL STOCK NUMBER & REFERENCE NUMBER CROSS-REFERENCE
TO FIGURE & ITEM NUMBER (Continued)**

FEDERAL STOCK NUMBER	FIGURE NUMBER		ITEM NUMBER OR REF. DESIGNATION	FEDERAL STOCK NUMBER	FIGURE NUMBER		ITEM NUMBER OR REF. DESIGNATION	FEDERAL STOCK NUMBER	FIGURE NUMBER		ITEM NUMBER OR REF. DESIGNATION
	REF NO.	MFG CO.			FIG NO.	REF NO.			MFG CO.	FIG NO.	
553-9809-003	13499		A6A3A1	57-3510	78488	3-9	A8A3E6	6S8083	56289	3-38	A8A3E47C160
553-9809-003	13499		A6A3A2	59-410-1003	02660	3-40	A8A3XV3	6S8083	56289	3-38	A8A3E47C161
553-9810-003	13499		A6A1A1	59-7159	11707		A8A1M101	6S8083	56289	3-38	A8A3E47C177
553-9810-003	13499		A6A2A1	6-4011-4 6SPLINE 416657	08664		A8A4A6MP44H1	6S8083	56289	3-38	A8A3E47C178
554-7047-002	13499		A5A1E1	6L2FF	96881		A8A4MP1	6S8083	56289	3-38	A8A3E47C183
554-7048-002	13499		A5A1MP2	6L2FF	96881		A8A4MP2	6S8083	56289	3-39	A8A3E48C166
554-7049-002	13499		A5MP4	6L2FF	96881		A8A4MP3	6S8083	56289	3-39	A8A3E48C171
554-7050-002	13499		A5A1	6L2FF	96881		A8A4MP4	6S8083	56289	3-39	A8A3E48C173
554-7051-002	13499		A5H4	6L2FF	96881		A8A4MP5	6S8083	56289	3-39	A8A3E48C182
554-7052-003	13499		A5E3	6L2FF	96881		A8A4MP6	6S8083	56289	3-54	A8A7E1C11
557-018-8-05E	72982	3-58	A8A7E5C72	6S8082	56289	3-20	A8A2E1C1	6S8083	56289	3-54	A8A7E1C18
557-018-8-50E	72982	3-58	A8A7E5C74	6S8082	56289	3-20	A8A2E134	6S8083	56289	3-54	A8A7E1C5
557-018-8-50E	72982	3-58	A8A7E5C76	6S8082	56289	3-54	A8A7E1C1	6S8083	56289	3-55	A8A7E2C23
557-018-8-50E	72982	3-58	A8A7E5C78	6S8082	56289	3-54	A8A7E1C10	6S8083	56289	3-55	A857E2C25
557-018-8-50E	72982	3-58	A8A7E5C80	6S8082	56289	3-54	A8A7E1C19	6S8083	56289	3-55	A8A7E2C29
557-018-8-50E	72982	3-58	A8A7E5C82	6S8082	56289	3-54	A8A7E1C7	6S8083	56289	3-55	A87E2C32
557-018-8-50E	72982	3-58	A8A7E5C84	6S8082	56289	3-54	A8A7E1C8	6S8083	56289	3-55	A8A7E2C35
557-018-8-50E	72982	3-58	A8A7E5C86	6S8082	56289		A8A7E2C22	6S8083	56289	3-55	A8A7E2C36
557-018-8-50E	72982	3-58	A8A7E5C88	6S8082	56289	3-55	A8A7E2C30	6S8083	56289	3-57	A8A7E4C57
557-018-8-50E	72982	3-58	A8A7E5C90	6S8082	56289	3-59	A8A7E6C102	6S8083	56289	3-57	A8A7E4C59
557-099-5-25A	72982	3-36	A8A3A13C266	6S8082	56289	3-59	A8A7E6C112	6S8083	56289	3-57	A8A7E4C60
557-099-5-30E	72982	3-35	A8A3613C254	6S8082	56289	3-59	A8A7E6C94	6S8083	56289	3-57	A8A7E4C63
557-099-5-30E	72982	3-36	A8A3A13C256	6S8083	56289	3-17	A8A1E1C18	6S8084	56289	3-21	A8A2E3C31
557-099-5-30E	72982	3-36	A8A3A13C258	6S8083	56289	3-40	A8A3C115	6S8084	56289	3-21	A8A2E5C26
557-099-5-30E	72982	3-36	A8A3A13C260	6S8083	56289	3-40	A8A3C116	6S8084	56289	3-66	A8A4A1C103
557-099-5-30E	72982	3-63	A8A3A13C262	6S8083	56289	3-40	A8A3C293	6S8084	56289	3-66	A8A4A1C104
557-099-5-30E	72982	3-36	A8A3A13C264	6S8083	56289	3-37	A8A3E46C247	600D1070050DJ5	56289	3-45	A8A5C26
557-099-5-30E	72982	3-54	A8A7E1C15	6S8083	56289	3-37	A8A3E46C269	600D136F200DG5	56259	3-50	A8A5C1
557-099-8-50E	72982	3-21	A8A2E3C15	6S8083	56289	3-37	A8A3E46C272	600D476G050ED5	56289	3-50	A8A5B25
557-399-8-50E	72982	3-21	A8A2E1C17	6S8083	56289	3-37	A8A3E46C275	600D476G050DE5	56289	3-45	A8A5C27
557-099-8-50E	72982	3-36	A8A3A13C215	6S8083	56289	3-38	A8A3E47C142	600D476G050DE5	56289	3-15	A8A5C28
557-099-8-50E	72982	3-36	A8A31A13C250	6S8083	56289	3-38	A8A3E47C143	600D476G050DE5	56289	3-45	A8A5C29
557-099-8-50E	72982	3-36	A8A3613C252	6S8083	56289	3-38	A8A3E47C150	610D105M200BD5	56289		A81ATB6C1
57-3540	78488	3-9	A8A3E1	6S8083	56289	3-38	A8A3E470151	610D255F100BD5	56289	3-67	A8A4C26
57-3540	78488	3-9	A8A3E2	6S8083	56289	3-38	A8A3E47C154	610D255F100BD5	56289	3-67	A84AC27
57-3540	78488	3-9	A8A3E3	6S8083	56289	3-38	A8A3E47C156	610D255F100BD5	56289		A8A4FL2C236
57-3540	78488	3-9	A8A3E4	6S8083	56289	3-38	A8A3E47C158	614B	57714		A8A4A1E1
57-3540	78488	3-9	A8A3E5	6S8083	56289	3-38	A8A3E47C159	678-0084-000	13499	3-17	A8A1E1L2

**SECTION IV INDEX-FEDERAL STOCK NUMBER & REFERENCE NUMBER CROSS-REFERENCE
TO FIGURE & ITEM NUMBER (Continued)**

FEDERAL STOCK NUMBER	FIGURE NUMBER		ITEM NUMBER OR REF. DESIGNATION	FEDERAL STOCK NUMBER	FIGURE NUMBER		ITEM NUMBER OR REF. DESIGNATION	FEDERAL STOCK NUMBER	FIGURE NUMBER		ITEM NUMBER OR REF. DESIGNATION
	REF NO.	MFG CO.			FIG NO.	REF NO.			MFG CO.	FIG NO.	
68NM62	72962		A6A3MP3H1	68-1660-26	72962		A8A4J7H1	68-1660-40	72962		A8A7P1H2
6BNM62	72962		A6A3MP3H2	68-1660-26	72962		A8A4J8H1	682268	19644	3-52	A8A6E2C1
68-1660-26	72962		A8A1P1H1	68-1660-26	72962		A8A2J8H2	69003-1183BROWN	73680	3-9	A8A3A1J1
68-1660-26	72962		A8A1P1H2	68-1660-26	72962		A8A4J9H1	69003-1183WRANGE	73680	3-9	ASA3A1J3
68-1660-26	72962		A8A2P3H1	68-1660-26	72962		A8A4J9H2	69003-1183RED	73680	3-9	A8A3A1J2
68-1660-26	72962		A8A2P3H2	68-1660-26	72962		A8A6E2R1H1	69003-1183YELLOW	73680	3-9	A8A3A1J4
68-1660-26	72962		A8A2P4H1	68-1660-26	72962		A8A6E2R1H2	72-140-1	12615	3-66	A8A4A1A1J1
68-1660-26	72962		ASA2P4H2	68-1660-26	72962		A8A6E2R2H1	72-140-1	12615	3-12	A8A6A1A1J1
68-1660-26	72962		A8A3A0S4ELH3	68-1660-26	72962		A8A6E2R2H2	72-100-2	12615	3-66	A8A4A1A1J2
68-1660-26	72962		A8A3A10S4E1H4	68-1660-26	72962		A8A7E5E2H1	72-120-2	12615	3-12	A8A6A1A1J2
6-1660-26	72962		A8A3A11S5E1H3	68-1660-26	72962		A8A7E5E2H2	72-120-3	12615	3-66	A8A4AA11J3
68-1660-26	72962		A8A3A11S5E1H4	68-1660-26	72962		A8A7E5E2H3	72-140-3	12615	3-53	A8A6A1A1J3
68-1660-26	72962		A8A3A112S8E1H1	68-1660-26	72962		A8A7E5E2Hr	72-140-4	12615	3-66	A8A4A1A1J4
68-1660-26	72962		A8A3A12S8E1H2	68-1660-26	72962		ASA7E7A2E1H1	72-140-4	12615	3-53	A8A6A1A1J4
68-1660-26	72962		A8A3A4A1H4	68-1660-26	72962		A8A7E7A2E1H2	72-140-5	12615	3-66	A8A4A1A1J5
68-1660-26	72962		A8A3A4A2H4	68-1660-26	72962		A8A7E7A2E2H1	72-153BLK	12615	3-11	A8A5A1J10
68-1660-26	72962		A8A3A4H1	68-1660-26	72962		A8A7E7A2E2H2	72-153BLU	12615	3-11	A8A5A1J6
68-1660-26	72962		A8A3A9A1S1E1H3	68-1660-40	72962		A8A3A2H2	72-153BRN	12615	3-21	A8A2A1J1
68-1660-26	72962		A8A3A9A1S1E1H4	68-1660-40	72962		A8A4K1H1	72-153BRN	12615	3-11	A8A5A1J1
68-1660-26	72962		A8A3A9A2S2E1H3	68-1660-40	72962		A8A4K1H2	72-153BRN	12615	3-11	A8A5AJ11
68-1660-26	72962		A8A3A9A2S2E1H4	68-1660-40	72962		A8A4K3H1	72-153GRA	12615	3-11	A8A5A1J8
68-1660-26	72962		A8A3A9A3S3E1H1	68-1660-40	72962		A8A4K3H2	72-153GRN	12615	3-11	A8A5A1J5
68-1660-26	72962		A8A3A9A3S3E1H2	68-1660-40	72962		A8A4A4H1	72-153ORN	12615	3-21	A8A2A1J3
68-1660-26	72962		A8A4J1H1	68-1660-40	72962		A8A4K4H2	72-153ORN	12615	3-11	A8A5A1J3
68-1660-26	72962		A8A4J1H2	68-1660-00	72962		A8A4K6H1	72-153ONN	12615	3-56	A8A7TB1E1J3
68-1660-26	72962		A8A4J10N1	68-1660-40	72962		A8A4K6H2	2-153RED	12615	3-20	A8A2A1J2
68-1660-26	72962		A8A4J10H2	68-1660-040	72962		A8A4R8H1	72-153RED	a12615	3-11	A8A5A1J2
68-1660-26	72962		A8A4J11H1	68-1660-40	72962		A8A4R8H2	72-153RED	12615	3-56	A8A7TB1E1J2
68-1660-26	72962		A8A4J11H2	68-1660-40	72962		A8A4T2H1	72-153RED	12615	3-11	A8A5AJ7T
68-1660-26	72962		A8A4J2H1	68-1660-40	72962		A8A4T2H2	72-153WHT	12615	3-11	A8A5A1J9
68-1660-26	72962		A8A4J2H2	68-1660-40	72962		A8A4T3H1	72-153YEL	12615	3-21	A8A5A1J4
68-1660-26	72962		A8A4J3H1	68-1660-40	72962		A8A4T3H2	72-153YEL	12615	3-11	A8A5A1J4
68-1660-26	72962		A8A4J3H2	68-1660-40	72962		A8A5E3H2	7T2-153YEL	12615	3-54	A8A7TB1E1J4
68-1660-26	72962		A8ABJ4H1	68-1660-40	72962		A8A5XC19H1	737-4765-000	13499		A2MP5
68-1660-26	72962		A8A4J4H2	68-1660-40	72962		A8A5XC19H2	747-4769-000	13499		A8MP7
68-1660-26	72962		A8A4J5H1	68-1660-40	72962		A8A5XC20H1	756-0317-003	13499		A8A7MP7
68-1660-26	72962		A8A4J6H1	68-1660-40	72962		A8A7E7A1H2	756-0318 -004	13499		A8A7MP6
68-1660-26	72962		A8A4J6H2	68-1660-40	72962		A8A7P1H1	756-0482-004	13499		A8MP4

**SECTION IV INDEX-FEDERAL STOCK NUMBER & REFERENCE NUMBER CROSS-REFERENCE
TO FIGURE & ITEM NUMBER (Continued)**

FEDERAL STOCK NUMBER	FIGURE NUMBER		ITEM NUMBER OR REF. DESIGNATION	FEDERAL STOCK NUMBER	FIGURE NUMBER		ITEM NUMBER OR REF. DESIGNATION	FEDERAL STOCK NUMBER	FIGURE NUMBER		ITEM NUMBER OR REF. DESIGNATION
	MFG CO.	FIG NO.			MFG CO.	FIG NO.			MFG CO.	FIG NO.	
REF NO.			ITEM NO OR REF DES.	REF NO.			ITEM NO OR REF DES	REF NO.			ITEM NO OR REF DES
756-2809-001	13499		CP1	772-8458-001	13499	3-64	A8A4T101				
756-3009-002	13499		A8MP3	7761	82219	3-23	A8A3TB2V2				
756-3160-003	13499	3-41	A8A315	7841	72825		A3E1				
756-3164-004	13499		A8A3A2	7841	72825		A3E2				
756-3166-003	13499	3-35	A8A3A12178	7841	72825		A3E3				
756-3167-003	13499	3-35	A843A12177	7841	72825		A3E4				
756-3168-005	13499		A8A3W2	7841	72825		A8A4A6E3				
756-3172-002	13499	3-41	A8A3A2	7841	72825		A8A4A6E4				
756-3173-002	13499		A8A3E11	7905	49956	3-9	A8A3V3				
756-3174-002	13499		A8A3A2MP1	797-4357-001	13499		A8MP1				
756-3175-003	13499		A8A3E12	797-4357-001	13499		A8MP2				
756-3176-003	13499		A8A3E13	797-4358-001	13499		A8MP3				
756-3177-003	13499		A8A3E14	812FF	96881		A8A4MP7				
756-4171-002	13499		A8A7E7A2MP7	812FF	96881		A8A4MP8				
756-4171-002	13499		A8A7E7A2MP8	805-014XV0103Z	72982	3-52	A8A6E2C11				
756-4179-003	13499	3-41	A8A314	850S100N	71590	3-64	A8A4A16C115				
756-5247-002	13499		A8A4A6A10MP3	850S20z	71590	3-64	A8A4A16C111				
756-7565-002	13499		A8A4A3	850S20Z	71590	3-64	A8A4A16C120				
756-7565-002	13499		A8A4A4	850S20Z	71590	3-64	A8A4A16C121				
756-7600-004	13499		A8A7E7A2E3	850S40Z	71590	3-64	A8A4A16C118				
756-7600-004	13499		A8A7E7A2E4	850S50Z	71590	3-64	A8A4A16C116				
756-7602-002	13499		A8A7ESMP6	850S50Z	71590	3-64	A8A4A16C117				
756-7606-003	13499	3-52	A8A6E2A1	88-8TM	02660	3-45	A8A5XC19				
756-8606-003	13499		A8A4MP25	88-8TM	02660	3-45	A8A5XC20				
757-4763-000	13499		MP4	8942	76854		A8A7E7A1H4				
157-1764-000	13499		A7P1	905	75543		A8A3H2				
757-4764-000	13499		A7MP2	905	75543		A8A4H4				
757-4766-0000	13499		A3P4	905	75543		A8A4H5				
757-4767-000	13499		A8MP5	911	75543		A8A1H6				
757-4768-00000	13499		AA8MP3	930-0524-00000	13499	3-45	ASA5C16				
757-4768-000	13499		A8MP6	955-0211UJX149	77872		A5W1				
761-5006-001	13499		A8A3A9An1S	99-012-062-0312	72962		A8A41109MP5				
763F2	10646	3-16	A8A1R80	99-012-062-0312	72962		A8A41112MP4				
763F28	10646	3-17	ASAT1ER1R2	99-012-062-0500	72962		A8A411009MP6				
763F28	10646	3-17	A8A1E1R85	99-012-062-0500	72962		A8A4110MP2				
763F28	10646	3-19	ABA1E3R67	99-012-062-0500	72962		A8A41111MP5				
763H10	10646	3-20	A8A2E2RT1	99-012-062-0500	72962		A8A41112MP3				
767-0502-000	13499		A4MP2								

**SECTION V INDEX-REFERENCE DESIGNATION
CROSS-REFERENCE TO PAGE NUMBER**

REFERENCE DESIGNATION	PAGE NUMBER	REFERENCE DESIGNATION	PAGE NUMBER	REFERENCE DESIGNATION	PAGE NUMBER
A1	4	A3E3H3	6	A4A1E1MP9	7
A1MP1	4	A3E3H4	6	A4A1MP1	7
A1MP2	4	A3E3H5	6	A4A2	7
A2	4	A3E4	6	A5	7
A2A1	4	A3E4R1	6	A5A1	7
A2A1MP1	4	A3E4H2	6	A5A1E1	7
A2A1MP1H1	4	A3E4H3	6	A5A1MP1	7
A2A2	4	A3E4H4	6	A5A1MP2	7
A2A2MP1	4	A3E4H5	6	A5E1	7
A2A2MP1H1	4	A3E5	6	A5E2	7
A2J1	4	A3E6	6	A5E2	7
A2J1H1	4	A3E7	6	A5E2H1	7
A2J1H2	4	A3E8	6	A5E2H2	7
A2J2	4	A3MP1	4	A5E2H3	7
A2J2H1	4	A3MP2	5	A5E3	7
A2J2H2	4	A3MP2H11	5	A5E3	8
A2J2H3	4	A3MP2H2	5	A5E3H1	8
A2MP1	4	A3MP2H3	5	A5E3H2	8
A2MP2	4	A3MP2H4	5	A5E4	7
A2MP3	4	A3MP2H5	5	A5E5	7
A2MP4	4	A3MP2H6	5	A5H1	8
A2MP5	4	A3MP2H7	5	A5MP1	7
A3	4	A3MP2H8	5	A5MP2	7
A3E1	5	A3MP3	5	A5MP3	7
A3E1H1	5	A3MP4	5	A5MP4	7
A3E1H2	5	A3P1	5	A5MP5	7
A3E1H3	5	A3P1H1	5	A5W1	8
A3E1H4	5	A4	6	A6	8
A3E1H5	5	A4A1	6	A6A1	8
A3E2	5	A4A1E1	6	A6AJA1	8
A3E2H1	5	A4A1E1MP1	6	A6A1A1H1	8
A3E2H2	5	A4A1E1MP2	6	A6A1A1MP1	8
A3E2H3	5	A4A1E1MP3	6	A6A1A1MP2	8
A3E2H4	5	A4A1E1MP4	6	A6A1A1MP3	8
A3E2H5	5	A4A1E1MP5	6	A6A1MP1	8
A3E3	6	A4A1E1MP6	7	A6A2	8
A3E3H1	6	A4A1E1MP7	7	A6A2A1	8
A3E3H2	6	A4A1E1MPB	7	A6A2A1H1	8

**SECTION V INDEX-REFERENCE DESIGNATION
CROSS-REFERENCE TO PAGE NUMBER**

REFERENCE DESIGNATION	PAGE NUMBER	REFERENCE DESIGNATION	PAGE NUMBER	REFERENCE DESIGNATION	PAGE NUMBER
A6A2A1MP1	8	A6MP7	9	A7A1MP5	10
A6A2A1MP2	8	A6MP7H1	9	A7A1MP6	10
A6A2A1MP3	8	A6MP7H2	9	A7A1MP7	11
A6A2MP1	8	A6MP8	10	A7A1MP8	11
A6A3	9	A6MP9	10	A7A1MP9	11
A6A3A1	9	A7	10	A7A2	12
A6A3A1H1	9	A7A1	10	A7A2A1	11
A6A3A1R1	9	A7A1A1	11	A7A2A1MP1	13
A6A3A1MP1	9	A7A1A1MP1	11	A7A2A1MP2	13
A6A3A1MP2	9	A7A1A1MP2	11	A7A2A1MP3	13
A6A3A1MP3	9	A7A1A1MP3	11	A7A2A2	13
A6A3A2	9	A7A1A2	11	A7A2A2MP1	13
A6A3A2R1	10	A7A1A2MP1	11	A7A2A2MP2	13
A6A3A2H1	10	A7A1A2MP2	11	A7A2A2MP3	13
A6A3A2H1	10	A7A1A2MP3	12	A7A2E1	12
A6A3A2MP2	10	A7A1E1	10	A7A2E1P1	12
A6A3A2MP3	10	A7A1E1MP1	10	A7A21W1	12
A6A3MP1	9	A7A1E1MP1	10	A7A2H1	13
A6A3MP2	9	A7A1H1	12	A7A2H2	13
A6A3MP3	9	A7A1H2	12	A7A2MP1	12
A6A3MP3H1	9	A7A1MP1	10	A7A2MP10	12
A6A3MP3H2	9	A7A1MP10	11	A7A2MP10H1	12
A6A3MP3H3	9	A7A1MP10R1	11	A7A2MP10H2	12
A5A3MP3H4	9	A7A1MP10H2	11	A7A2MP10H3	12
A6A3MP3H5	9	A7A1MP10H3	11	A7A2MP10H4	12
A6A3MP3H6	9	A7A1MP10H4	11	A7A2MP10H5	12
A6A4	10	A7A1MP10H5	11	A7A2MP10H6	12
A6A4MP1	10	A7A1MP10H6	11	A7A2MP11	12
A6A4MP2	10	A7A1MP11	11	A7A2MP11H1	12
A6MP1	8	A7A1MP11H1	11	A7A2MP11H2	13
A6MP10	10	A7A1KP11H2	11	A7A2MP11H3	13
A6MP2	8	A7A1MP11H3	11	A7A2MP11H4	13
A6MP3	8	A7A1MP11H4	11	A7A2MP11H5	13
A6MP4	8	A7A1MP11H5	11	A7A2MP11H6	13
A6MP5	9	A7A1MP11H6	11	A7A2MP2	12
A6MP5H1	9	A7A1MP2	10	A7A2MP3	12
A6MP6	9	A7A1MP3	10	A7A2MP4	12
A6MP6H1	9	A7A1J4P4	10	A7A2MP5	12

**SECTION V INDEX-REFERENCE DESIGNATION
CROSS-REFERENCE TO PAGE NUMBER**

REFERENCE DESIGNATION	PAGE NUMBER	REFERENCE DESIGNATION	PAGE NUMBER	REFERENCE DESIGNATION	PAGE NUMBER
A1	4	A3E3H3	6	A4A1E1MP9	7
A1MP1	4	A3E3H4	6	A4A1MP1	7
A1MP2	4	A3E3H5	6	A4A2	7
A2	4	A3E4	6	A5	7
A2A1	4	A3E4R1	6	A5A1	7
A2A1MP1	4	A3E4H2	6	A5A1E1	7
A2A1MP1H1	4	A3E4H3	6	A5A1MP1	7
A2A2	4	A3E4H4	6	A5A1MP2	7
A2A2MP1	4	A3E4H5	6	A5E1	7
A2A2MP1H1	4	A3E5	6	A5E2	7
A2J1	4	A3E6	6	A5E2	7
A2J1H1	4	A3E7	6	A5E2H1	7
A2J1H2	4	A3E8	6	A5E2H2	7
A2J2	4	A3MP1	4	A5E2H3	7
A2J2H1	4	A3MP2	5	A5E3	7
A2J2H2	4	A3MP2H11	5	A5E3	8
A2J2H3	4	A3MP2H2	5	A5E3H1	8
A2MP1	4	A3MP2H3	5	A5E3H2	8
A2MP2	4	A3MP2H4	5	A5E4	7
A2MP3	4	A3MP2H5	5	A5E5	7
A2MP4	4	A3MP2H6	5	A5H1	8
A2MP5	4	A31dP2H7	5	A5MP1	7
A3	4	A3MP2H8	5	A5MP2	7
A3E1	5	A3MP3	5	A5MP3	7
A3E1H1	5	A3MP4	5	A5MP4	7
A3E1H2	5	A3P1	5	A5MP5	7
A3E1H3	5	A3P1H1	5	A5W1	8
A3E1H4	5	A4	6	A6	8
A3E1H5	5	A4A1	6	A6A1	8
A3E2	5	A4A1E1	6	A6AJA1	8
A3E2H1	5	A4A1E1MP1	6	A6A1A1H1	8
A3E2H2	5	A4A1E1MP2	6	A6A1A1MP1	8
A3E2H3	5	A4A1E1MP3	6	A6A1A1MP2	8
A3E2H4	5	A4A1E1MP4	6	A6A1A1MP3	8
A3E2H5	5	A4A1E1MP5	6	A6A1MP1	8
A3E3	6	A4A1E1MP6	7	A6A2	8
A3E3H1	6	A4A1E1MP7	7	A6A2A1	8
A3E3H2	6	A4A1E1MPB	7	A6A2A1H1	8

**SECTION V INDEX-REFERENCE DESIGNATION
CROSS-REFERENCE TO PAGE NUMBER**

REFERENCE DESIGNATION	PAGE NUMBER	REFERENCE DESIGNATION	PAGE NUMBER	REFERENCE DESIGNATION	PAGE NUMBER
A6A2A1MP1	8	A6MP7	9	A7A1MP5	10
A6A2A1MP2	8	A6MP7H1	9	A7A1MP6	10
A6A2A1MP3	8	A6MP7H2	9	A7A1MP7	11
A6A2MP1	8	A6MP8	10	A7A1MP8	11
A6A3	9	A6MP9	10	A7A1MP9	11
A6A3A1	9	A7	10	A7A2	12
A6A3A1H1	9	A7A1	10	A7A2A1	11
A6A3A1R1	9	A7A1A1	11	A7A2A1MP1	13
A6A3A1MP1	9	A7A1A1MP1	11	A7A2A1MP2	13
A6A3A1MP2	9	A7A1A1MP2	11	A7A2A1MP3	13
A6A3A1MP3	9	A7A1A1MP3	11	A7A2A2	13
A6A3A2	9	A7A1A2	11	A7A2A2MP1	13
A6A3A2R1	10	A7A1A2MP1	11	A7A2A2MP2	13
A6A3A2H1	10	A7A1A2MP2	11	A7A2A2MP3	13
A6A3A2H1	10	A7A1A2MP3	12	A7A2E1	12
A6A3A2MP2	10	A7A1E1	10	A7A2E1P1	12
A6A3A2MP3	10	A7A1E1MP1	10	A7A21W1	12
A6A3MP1	9	A7A1E1MP1	10	A7A2H1	13
A6A3MP2	9	A7A1H1	12	A7A2H2	13
A6A3MP3	9	A7A1H2	12	A7A2MP1	12
A6A3MP3H1	9	A7A1MP1	10	A7A2MP10	12
A6A3MP3H2	9	A7A1MP10	11	A7A2MP10H1	12
A6A3MP3H3	9	A7A1MP10R1	11	A7A2MP10H2	12
A5A3MP3H4	9	A7A1MP10H2	11	A7A2MP10H3	12
A6A3MP3H5	9	A7A1MP10H3	11	A7A2MP10H4	12
A6A3MP3H6	9	A7A1MP10H4	11	A7A2MP10H5	12
A6A4	10	A7A1MP10H5	11	A7A2MP10H6	12
A6A4MP1	10	A7A1MP10H6	11	A7A2MP11	12
A6A4MP2	10	A7A1MP11	11	A7A2MP11H1	12
A6MP1	8	A7A1MP11H1	11	A7A2MP11H2	13
A6MP10	10	A7A1KP11H2	11	A7A2MP11H3	13
A6MP2	8	A7A1MP11H3	11	A7A2MP11H4	13
A6MP3	8	A7A1MP11H4	11	A7A2MP11H5	13
A6MP4	8	A7A1MP11H5	11	A7A2MP11H6	13
A6MP5	9	A7A1MP11H6	11	A7A2MP2	12
A6MP5H1	9	A7A1MP2	10	A7A2MP3	12
A6MP6	9	A7A1MP3	10	A7A2MP4	12
A6MP6H1	9	A7A1J4P4	10	A7A2MP5	12

**SECTION V INDEX-REFERENCE DESIGNATION
CROSS-REFERENCE TO PAGE NUMBER**

REFERENCE DESIGNATION	PAGE NUMBER	REFERENCE DESIGNATION	PAGE NUMBER	REFERENCE DESIGNATION	PAGE NUMBER
A7A2MP6	12	A8A1E1K1	128	A8A1E2C3	122
A7A2MP7	12	A8A1E1L1	128	A8A1E2C4	122
A7A2MP8	12	A8A1K1L1H1	128	A8A1E2C5	121
A7A2MP9	12	A8A1E1L2	128	A8A1E2C6	122
A7MP1	10	A8A1E1L2H1	128	A8A1E2C7	122
A7MP1	13	A8A1E1Q5	129	A8A1E2C8	122
A7MP2	13	A8A1E1Q6	129	A8A1E2C9	121
A8	13	A8A1E1Q7	129	A8A1E2E1	121
A8A1	121	A8A1E1R3	128	A8A1E2E2	122
A8A1C43	127	A8A1E1R34	128	A8A1E2E3	122
A8A1C44	127	A8A1E1R35	129	A8A1E2E4	-122
A8A1E1	127	A8A1E1R36	129	A8A1E2E5	122
A8A1E1CR18	129	A8A1E1R37	129	A8A1E2H6	121
A8A1E1CR7	129	A8A1E1R38	128	A8A1E2J1	122
A8A1E1CR8	129	A8A1E1R39	128	A8A1E2J2	122
A8A1E1CR9	129	A8A1E1R40	128	A8A1E2J3	122
A8A1E1C1	127	A8A1E1R41	128	A8A1E2J4	122
A8A1E1C17	128	A8A1E1R42	129	A8A1E2J5	122
A8A1E1C18	127	A8A1E1R43	129	A8A1E2J6	122
A8A1E1C19	128	A8A1E1R44	128	A8A1E2J7	122
A8A1E1C20	128	A8A1E1R83	129	A8A1E2Q1	124
A8A1E1C21	128	A8A1E1R85	129	A8A1E2Q2	124
A8A1E1C22	127	A8A1E2	121	A8A1E2Q3	124
A8A1E1C23	128	A8A1E2CR1	124	A8A1E2Q4	124
A8A1E1C24	128	A8A1E2CR17	124	A8A1E2R1	122
A8A1E1C25	128	A8A1E2CR2	124	A8A1E2R10	123
A8A1E1C26	127	A8A1E2CR3	124	A&A1E2R11	123
A8A1E1C26	127	A8A1E2CR4	124	A8A1E2R12	124
A8A1E1C26	127	A8A1E2CR5	124	A8A1E2R13	123
A6A1E1C26	128	A8A1E2CR6	124	A8A1E2R14	123
A8A1E1C26	128	A8A1E2C10	122	A8A1E1R15	123
A8A1E1E1	127	A8A1E2C11	122	A8A1E2R16	123
A8A1E1H6	127	A8A1E2C12	122	A8A1E2R17	123
A8A1E1J10	128	A8A1E2C13	122	A8A1E2R18	123
A8A1E1J11	126	A8A1R2C14	122	A8A1E2R19	123
A8A1Z1J12	128	A8A1E2C15	122	A8A1E2R2	123
A8A1E1J8	128	A8A1E2C16	122	A8A1E2R20	123
A8A1E1J9	128	A8A1E2C2	122	A8A1E2R21	124

**SECTION V INDEX-REFERENCE DESIGNATION
CROSS-REFERENCE TO PAGE NUMBER**

REFERENCE DESIGNATION	PAGE NUMBER	REFERENCE DESIGNATION	PAGE NUMBER	REFERENCE DESIGNATION	PAGE NUMBER
A8A1E2R22	123	A8A1E3E1	124	A8A1E3R73	126
A8A1E2R23	123	A8A1E3E2	125	A8A1E3R74	126
A8A1E2R24	123	A8A1E3E3	125	A8A1E3R75	126
A8A1E2R25	123	A8A1E3E4	125	A8A1E3R76	126
A8A1E2R26	123	A8A1E3H4	124	A8A1E3R77	126
A8A1E2R27	124	A8A1E3J13	125	A8A1E3R78	126
A8A1E2R28	123	A8A1E3J14	125	A8A1E4	130
A8A1E2R29	123	A8A1E3J15	125	A8A1E4H1	130
A8A1E2R30	123	A8A1E3J16	125	A8A1E4H2	130
A8A1E2R31	123	A8A1E3L3	125	A8A1E5	130
A8A1E2R32	123	A8A1E3Q10	127	A8A1E5H1	130
A8A1E2R33	124	A8A1E3Q8	127	A8A1E5H2	130
A8A1E2R4	123	A8A1E3Q9	127	A8A1E5H3	130
A8A1E2R5	124	A8A1E3R45	125	A8A1E6	130
A8A1E2R6	123	A8A1E3R46	126	A8A1MP1	127
A8A1E2R7	123	A8A1E3R47	125	A8A1MP2	129
A8A1E2R8	124	A8A1E3R48	126	A8A1MP2H1	129
A8A1E2R9	123	A8A1E3R49	126	A8A1MP2R2	129
A8A1E2T1	124	A8A1E3R50	126	A8A1MP2H3	129
A8A1E3CR10	127	A8A1E3R51	125	A8A1MP2H4	129
A8A1E3CR11	126	A8A1E3R52	126	A8A1P1	127
A8A1E3CR12	127	A8A1E3R53	125	A8A1P1H1	127
A8A1E3CR13	127	A8A1E3R54	126	A8A1P1H2	127
A8A1F3C28	125	A8A1E3R55	126	A8A1P1H3	127
A8A1E3C29	124	A8A1E3R56	126	A8A1P1R4	127
A8A1E3C30	124	A8A1E3R57	126	A8A1P1H5	127
A8A1E3C31	124	A8A1E3R58	126	A8A1P1H6	127
A8A1E3C32	125	A8A1E3R59	126	A8A1Q11	130
A8A1E3C33	125	A6A1E3R60	126	A8A1Q11H1	130
A8A1E3C34	125	A8A1E3R61	126	A8A1Q11H2	130
A8A1E3C35	125	A8A1E3R62	126	A8A1Q11H3	130
A8A1E3C36	125	A8A1E3R63	125	A8A1R79	129
A8A1E3C37	125	A8A1E3R64	127	A8A1R80	130
A8A1E3C38	125	A8A1E3R65	126	A8A1R81	129
A8A1E3C40	125	A8A1E3R66	126	A8A1R82	129
A8A1E3C41	125	A8A1E3R67	126	A8A1R84	129
A8A1E3C42	124	A8A1E3R68	126	A8A1T2	130
A8A1E3	124	A8A1E3R72	125	A8A1T2H1	130

**SECTION V INDEX-REFERENCE DESIGNATION
CROSS-REFERENCE TO PAGE NUMBER**

REFERENCE DESIGNATION	PAGE NUMBER	REFERENCE DESIGNATION	PAGE NUMBER	REFERENCE DESIGNATION	PAGE NUMBER
A8A1T2H2	130	A8A2E1C7	51	A8A2E2R16	49
A8A1T2H3	130	A8A2E1C8	51	A8A2E2R17	49
A8A1T2H4	130	A8A3E1C9	51	A8A2E2R18	50
A8A1T3	130	A8A2E1E1	50	A8A2E2H19	50
A8A1T3H1	130	A8A2E1H4	50	A8A2E2T2	50
A8A1T3H2	130	A8A2E1L1	51	A8A2E3	45
A8A1T3H3	130	A8A2E1L2	51	A8A2E3CR7	46
A8A1T3H4	130	A8A2E1L3	51	A8A2E3CR8	46
A8A1TS	130	A8A2E1H1	51	A8A2E3C11	45
A8A1T5H1	130	A8A2E1R2	51	A8A2E3C12	45
A8A1T5H2	131	A8A2E1H3	51	A8A2E3C13	45
A8A1T5H3	131	A8A2E1R4	51	A8-2E3C14	45
A8A1T5H4	131	A8A2E1R41	51	A8A2E3C15	46
A8A11	129	A8A2E1R5	51	A8A2E3C25	45
A8A2	45	A8A2E1R6	51	A8A2E3C28	45
A8A2A1	48	A8A2E1R7	51	A8A2E3C29	46
A8A2A1J1	48	A8A2E1R8	51	A8A2E3C30	45
A8A2A1J2	48	A8A2E2	49	A8A2E3C31	45
A8A2A1J3	48	A8A2E2C10	49	A8A2E3E1	45
A8A2A1J4	48	A8A2E2C3	49	A8A2E3H3	45
A8A2CR9	52	A8A2E2C5	49	A8A2E3L8	46
A8A2C33	48	A8A2E2E1	49	A8A2E3Q2	46
A8A2C37	48	A8A2E2H2	49	A8A2E3H20	46
A8A2E1	50	A8A2E2L4	49	A8A2E3R21	46
A8A2E1CR1	51	A8A2E2Q1	50	A8A2E3R22	46
A8A2E1C1	50	A8A2E2RT1	50	A8A2E3R24	46
A8A2E1C2	51	A8A2E2R13	49	A8A2E3R36	46
A8A2E1C34	50	A8A2E2R14	49	A8A2E3R37	46
A8A2E1C35	51	A8A2E2R14	49	A8A2E3R38	46
A8A2E1C36	50	A8A22R14	49	A8A2E4	46
A8A2E1C36	51	A8A2E2H14	49	A8A2E4C16	46
A8A2E1C36	51	A8A2E2R14	49	A8A2E4C17	46
A8A2E1C36	51	A8A2E2H14	49	A8A3E4C18	46
A8A2E1C36	51	A8A3E2H14	49	A8A2E4C19	46
A8A2E1C36	51	A8A2E2H14	49	A8A2E4C20	46
A8A2E1C36	51	A8A22R14	49	ABA2E4C21	46
A8A2E1C4	51	A8A2E2R14	49	A8A2E4C22	46
A8A2E1C6	50	A8A2E2R15	49	A8A2E4C23	46

**SECTION V INDEX-REFERENCE DESIGNATION
CROSS-REFERENCE TO PAGE NUMBER**

REFERENCE DESIGNATION	PAGE NUMBER	REFERENCE DESIGNATION	PAGE NUMBER	REFERENCE DESIGNATION	PAGE NUMBER
A8A2E4E1	46	A8A2L10	48	A8A3A1J3	81
A8A2E4H3	46	A8A2L9	48	A8A3A1J4	81
A8A2E4L5	46	A8A2MP1	50	A8A3A10	115
A8A2E4Q3	47	A8A2MP1H1	50	A8A3A10C68	116
A8A2E4Q4	47	A8A2MP1H2	50	A8A3A10C69	116
A8A2EbR23	47	A8A2MP1H3	50	A8A3A10C70	116
A8A2E4R25	47	A8A2MP1H4	50	A8A3A10C71	116
A8A2E4R26	47	A8A2MP2	50	A8A3A10C72	116
A8A2E4R28	47	A8A2MP2H1	50	A8A3A10C73	116
A8A2E4R29	47	A8A2MP2H2	50	A8A3A10C74	116
A8A2E4R30	47	A8A2MP2H3	50	A8A3A10C75	116
A8A2E4R31	47	A8A2MP2H4	50	A8A3A10C76	116
A8A2E4R32	47	A8A2MP3	52	A8A3A10C77	116
A8A2E4R39	47	A8A2MP3H1	52	A8A3A10C78	116
A8A2E5	47	A8A2P3	48	A8A3A10C79	116
A8A2E5C24	47	A8A2P3A1	49	A8A3A10C80	116
A8A2E5C26	47	A8A2P3H1	48	A8A3A10C81	116
A8A2E5C27	47	A8A2P3H2	48	A8A3A10C82	116
A8A2E5C32	47	A8A2P3H3	48	A8A3A10C83	116
A8A2E5E1	47	A8A2P3H4	48	A8A3A10C84	116
A8A2E5H2	47	A8A2P3H5	48	A8A3A10C85	116
A8A2E5K1	47	A8A2P3H6	48	A8A3A10C86	116
A8A2E5L6	47	A8A2P4	48	A8A3A10C87	116
A8A2E5L7	47	A8A2P4A1	49	A8A3A10E5	117
A8A2E5Q5	48	A8A2P4A2	49	A8A3A10E6	117
A8A2E5R33	47	A8A2P4A3	49	A8A3A10L47	117
A8A2E5R34	47	A8A2P4H1	48	A8A3A10L48	117
A8A2E5R35	47	A8A2P4H2	48	A8A3A10L49	117
A8A2E5R40	47	A8A2P4H3	48	A8A3A10L50	117
A8A2E5T3	48	A8A2P4H4	48	A8A3A10L51	117
A8A2E6	52	A8A2P4H5	48	A8A3A10S4	115
A8A2E7	52	A8A2P4H6	48	A8A3A10S4E1	115
A8A2E8	52	A8A2R27	52	A8A3A10S4E1H1	116
A8A2E9	52	A8A2R45	52	A8A3A10S4E1H2	116
A8A2E9H1	52	A8A3	72	A8A3A10S4E1H3	116
A8A2E9H2	52	A8A3AZ	81	A8A3A10S4E1H4	116
A8A2FL1	50	A8A3AZJ1	81	A8A3A10S4E2	116
A8A2H1	50	A8A3AZJ2	81	A8A3A11	117

**SECTION V INDEX-REFERENCE DESIGNATION
CROSS-REFERENCE TO PAGE NUMBER**

REFERENCE DESIGNATION	PAGE NUMBER	REFERENCE DESIGNATION	PAGE NUMBER	REFERENCE DESIGNATION	PAGE NUMBER
A8A3A11C100	117	A8A3A12C125	119	A8A3A13C254	120
A8A3A11C101	118	A8A3A12C126	119	A8A3A13C255	120
A8A3A11C102	118	A8A3A12C127	119	A8A3A13C256	120
A8A3A11C103	118	A8A3A12C128	119	A8A3A13C257	120
A8A3A11C104	117	A8A3A12C129	119	A8A3A13C253	120
A8A3A11C105	118	A8A3A12C130	119	A8A3A13C259	120
A8A3A11C106	117	A8A3A12C131	119	A8A3A13C260	120
A8A3A11C107	118	A8A3A12C132	119	A8A3A13C261	120
A8A3A11C108	117	A3A3A12C133	119	A8A3A13C262	120
A8A3A11C109	118	A8A3A12C134	119	A8A3A13C263	120
A8A3A11C110	117	A8A3A12C135	119	A8A3A13C264	120
A8A3A11C111	117	A8A3A12C136	119	A8A3A13C265	120
A8A3A11C112	117	A3A3A12C137	119	A8A3A13C266	120
A8A3A11C113	117	A8A3A12C138	119	A8A3A13C267	120
A8A3A11C114	117	A8A3A12C139	119	A8A3A13L103	121
A8A3A11C95	118	A8A3A12C140	119	A8A3A13MP1	120
A8A3A11C96	118	A8A3A12C141	119	A8A3A13MP1H1	120
A8A3A11C97	118	A8A3A12E11	119	A8A3A13S9	121
A8A3A11C98	117	A8A3A12E12	119	A8A3A2	83
A8A3A11C99	118	A8A3A12L77	120	A8A3A2	84
A8A3A11E7	118	A8A3A12L78	120	A8A3A2C350	84
A8A3A11E8	118	A8A3A12L79	119	A8A3A2C351	84
A8A3A11L62	118	A8A3A12L80	119	A8A3A2C352	89
A8A3A11L63	118	A8A3A12L81	119	A8A3A2H2	84
A8A3A11L64	118	A8A3A12S8	118	A8A3A2H2	84
A8A3A11L65	118	A8A3A12S8E1	118	A8A3A2MP1	83
A8A3A11L66	118	A8A3A12S8E1H1	118	A8A3A2MP1	84
A8A3A11S5	117	A8A3A12S8E1H2	118	A8A3A2MP2	83
A8A3A11S5E1	117	A8A3A12S8E1H3	118	A8A3A2MP3	83
A8A3A11S5E1H1	117	A8A3A12S8E1H4	118	A8A3A2W1	84
A8A3A11S5E1H2	117	A8A3A12S8E2	118	A8A3A3	84
A8A3A11S5E1H3	117	A8A3A13	120	A8A3A3E1	85
A8A3A11S5E1H4	117	A8A3A13C248	120	A8A3A3E2	85
A8A3A11S5E2	117	A8A3A13C249	120	A8A3A3H2	85
A8A3A12	118	A8A3A13C250	120	A8A3A3H2	85
A8A3A12C122	119	A8A3A13C251	120	A8A3A3H2	85
A8A3A12C123	119	A8A3A13C252	120	A8A3A3W1	85
A8A3A12C124	119	A8A3A13C253	120	ABA3A4	89

**SECTION V INDEX-REFERENCE DESIGNATION
CROSS-REFERENCE TO PAGE NUMBER**

REFERENCE DESIGNATION	PAGE NUMBER	REFERENCE DESIGNATION	PAGE NUMBER	REFERENCE DESIGNATION	PAGE NUMBER
A8A3A4A1	90	A8A3A4A1C313	91	A8A3A4A1L138H2	93
A8A3A4A1C304	92	A8A3A4A1C313	92	A8A3A4A1L139	93
A8A3A4A1C305	90	A8A3A4A1C313	92	A8A3A4A1L139H1	93
A8A3A4A1C305	91	A8A3A4A1E1	93	A8A3A4A1L139H2	93
A8A3A4A1C305	91	A8A3A4A1E10	94	A8A3A4A1L140	93
A8A3A4A1C305	91	A8A3A4A1E10H1	94	A8A3A4A1L140H1	93
A8A3A4A1C305	91	A8A3A4A1E11	94	A8A3A4A1L140H2	93
A8A3A4A1C305	91	A8A3A4A1E11H1	94	A8A3A4A1L141	93
A8A3A4A1C305	92	A8A3A4A1E12	94	A8A3A4A1L141H1	93
A8A3A4A1C306	92	A8A3A4A1E12H1	94	A8A3A4A1L141H2	93
A8A3A4A1C307	90	A8A3A4A1E2	93	A8A3A4A1L142	92
A8A3A4A1C307	91	A8A3A4ATE3	93	A8A3A4A1L142H1	92
A8A3A4A1C307	91	A8A3A4A1E4	94	A8A3A4A1L142H2	92
A8A3A4A1C307	91	A8A3A4A1E5	94	A8A3A4A1MP1	92
A8A3A4A1C307	91	A8A3A4A1E6	94	A8A3A4A1R174	93
A8A3A4A1C307	91	A8A3A4A1E7	94	A8A3A4A1R175	93
A8A3A4A1C307	92	A8A3A4A1E8	94	A8A3A4A1R176	93
A8A3A4A1C308	92	A8A3A4A1E9	94	A8A3A4A1R177	93
A8A3A4A1C309	90	A8A3A4A1E9H1	94	A8A3A4A1R178	93
A8A3A4A1C309	91	A8A3A4A1H4	90	A8A3A4A2	94
A8A3A4A1C309	91	A8A3A4A1H4	90	A8A3A4A2C298	97
A8A3A4A1C309	91	A8A3A4A1L125	92	A8A3A4A2C299	94
A8A3A4A1C309	91	A8A3A4A1L125H1	92	A8A3A4A2C299	94
A8A3A4A1C309	91	A8A3A4A1L125H2	92	A8A3A4A2C299	95
A8A3A4A1C309	92	A8A3A4A1L126	92	A8A3A4A2C299	95
A8A3A4A1C310	92	A8A3A4A1L126H1	92	A8A3A4A2C299	95
A8A3A4A1C311	90	A8A3A4A1L126H2	92	A8A3A4A2C299	95
A8A3A4A1C311	91	A8A3A4A1L127	92	A8A3A4A2C299	95
A8A3A4A1C311	91	A8A3A4A1L127H1	92	A8A3A4A2C299	96
A8A3A4A1C311	91	A8A3A4A1L127H2	92	A8A3A4A2C299	96
A8A3A4A1C311	91	A8A3A4A1L133	92	A8A3A4A2C299	96
A8A3A4A1C311	92	A8A3A4A1L133H1	93	A8A3A4A2C299	96
A8A3A4A1C311	92	A8A3A4A1L133H2	93	A8A3A4A2C299	96
A8A3A4A1C312	91	A8A3A4A1L134	93	A8A3A4A2C300	97
A8A3A4A1C313	91	A8A3A4A1L134H1	93	A8A3A4A2C301	94
A8A3A4A1C313	91	A8A3A4A1L134H2	93	A8A3A4A2C301	94
A8A3A4A1C313	91	A8A3A4A1L138	93	A8A3A4A2C301	95
A8A3A4A1C313	91	A8A3A4A1L138H1	93	A8A3A4A2C301	95

**SECTION V INDEX-REFERENCE DESIGNATION
CROSS-REFERENCE TO PAGE NUMBER**

REFERENCE DESIGNATION	PAGE NUMBER	REFERENCE DESIGNATION	PAGE NUMBER	REFERENCE DESIGNATION	PAGE NUMBER
A8A3A4A2C301	95	A8A3A4A2C317	95	A8A3A4A2L131H2	97
A8A3A4A2C301	95	A8A3A4A2C317	95	A8A3A4A2L132	97
A8A3A4A2C301	95	A8A3A4A2C317	95	A8A3A4A2L132H1	98
A8A3A4A2C301	96	A8A3A4A2C317	96	A8A3A4A2L132H2	98
A8A3A4A2C301	96	A8A3A4A2C317	96	A8A3A4A2L135	98
A8A3A4A2C301	96	A8A3A4A2C317	96	A8A3A4A2L135H1	98
A8A3A4A2C301	96	A8A3A4A2C317	96	A8A3A4A2L135H2	98
A8A3A4A2C301	97	A8A3A4A2C317	96	A8A3A4A2L136	98
A8A3A4A2C302	96	A8A3A4A2C317	97	A8A3A4A2L136H1	98
A8A3A4A2C303	94	A8A3A4A1E1	98	A8A3A4A2L136H2	98
A8A3A4A2C303	94	A8A3A4A2E10	98	A8A3A4A2L137	96
A8A3A4A2C303	95	A8A3A4A2E10H1	99	A8A3A4A2L137H1	98
A8A3A4A2C303	95	A8A3A4A2E11	99	A8A3A4A2L137H2	98
A8A3A4A2C303	95	A8A3A4A2E11H1	99	A8A3A4A2L143	97
A8A3A4A2C303	95	A8A3A4A2E12	99	A8A3A4A2L143H1	98
A8A3A4A2C303	96	A8A3A4A2E12H1	99	A8A3A4A2L143H2	97
A8A3A4A2C303	96	A8A3A4A2E2	98	A8A3A4A2L144	97
A8A3A4A2C303	96	A8A3A4A2E3	98	A8A3A4A2L144H1	97
A8A3A4A2C303	96	A8A3A4A2E4	98	A8A3A4A2L144H2	97
A8A3A4A2C303	96	A8A3A4A2E5	98	A8A3A4A2R172	98
A8A3A4A2C303	97	A8A3A4A2E6	98	A8A3A4A2R173	98
A8A3A4A2C314	95	A8A3A4A2E7	98	A8A3A4A2R179	98
A8A3A4A2C315	94	A8A3A4A2E8	98	A8A3A4CR10	90
A8A3A4A2C315	94	A8A3A4A2E9	98	A8A3A4CR9	90
A8A3A4A2C315	95	A8A3A4A2E9R1	98	A8A3A4C318	89
A8A3A4A2C315	95	A8A3A4A2R4	94	A8A3A4C319	89
A8A3A4A2C315	95	A8A3A4A2134	94	A8A3A4C320	90
A8A3A4A2C315	95	A8A3A4A2L128	97	A8A3A4C321	90
A8A3A4A2C315	96	A8A3A4A2L128H1	97	A8A3A4C322	90
A8A3A4A2C315	96	A8A3A4A2L128H2	97	A8A3A4C323	90
A8A3A4A2C315	96	A8A3A4A2L129	97	A8A3A4C324	90
A8A3A4A2C315	96	A8A3A4A2L129H1	97	A8A3A4C325	90
A8A3A4A2C315	96	A8A3A4A2L129H2	97	A8A3A4C326	90
A8A3A4A2C315	97	A8A3A4A2L130	97	A8A3A4C327	90
A8A3A4A2C316	95	A8A3A4A2L130H1	97	A8A3A4C328	90
A8A3A4A2C317	94	A8A3A4A2L130H2	97	A8A3A4C329	90
A8A3A4A2C317	95	A8A3A4A2L131	97	A8A3A4C330	89
A8A3A4A2C317	95	A8A3A4A2L131H1	97	A8A3A4C331	89

**SECTION V INDEX-REFERENCE DESIGNATION
CROSS-REFERENCE TO PAGE NUMBER**

REFERENCE DESIGNATION	PAGE NUMBER	REFERENCE DESIGNATION	PAGE NUMBER	REFERENCE DESIGNATION	PAGE NUMBER
A8A3A4C332	89	A8A3A4H2	99	A8A3A4S6	100
A8A314C333	89	A8A3A4MP1	99	A8A3A4S7	100
A8A3A4C334	89	A8A3A4MP1H1	99	A8A3A5	104
A8A3A4C335	89	A8A3A4MP1H2	99	A8A3A5H6	104
A8A3A4C336	89	A8A3A4MP1H3	99	A8A3A5MP1	104
A8A3A4C337	90	A8A3A4MP10	100	A8A3A5MP2	104
A8A3A4C338	89	A8A3A4MP2	99	A843A5MP3	104
A8A3A4C339	90	A8A3A4MP2H1	99	A8A3A5MP4	104
A8A3A4C340	90	A8A3A4MP2H2	99	A8A3A5MP5	104
A8A3A4C341	90	A8A3A4MP2H3	99	A8A3A6	104
A8A3A4C343	89	AAA3A4MP2H4	99	A8A3A6H6	104
A8A3A4C345	90	A8A3A4MP2H5	99	A8A3A6MP1	104
A8A3A4C349	90	A3A3A4MP3	99	A8A3A6MP2	104
A8A3A4E1	100	A8A3A4MP4	99	A6A3A6MP3	104
A8A3A4E1H1	100	A8A3A4MP5	100	A8A3A6MP4	104
A8A3A4EH2	100	A8A3A4MP6	100	A8A3A6MP5	104
A8A3A4E21	100	A8A3A4MP7	100	A8A3A6MP6	104
A8A3A4E21	100	A8-3A4MP8	100	A8A3A6MP7	104
A8A3A4E1H2	100	A8A3A4MP9	100	A8A3A7	106
A8A3A4E3	101	A8A3A4Q20	101	A8A3A7MP1	106
A8A3A4E3H1	101	A8A3A4Q21	101	A8A3A7MP2	106
A8A3A4E3H2	101	A8A3A4R156	100	A8A3A7MP3	106
A8A3A4E3H3	101	A8A3A4R157	100	A8A3A7MP4	106
A8A3A4L4	101	A8A3A4R158	100	ABA3A7MP5	106
A8A3A4E4H1	101	A8A3A4R159	99	A8A3A706	106
A8A3A4E4H2	101	A8A3A4R160	99	A8A3A8	106
A8A3A4E4H3	101	A8A3A4R161	99	A8A3A8A1	106
A8A3A4E6	89	A8A3A4R163	100	A8A3A8AMP1	106
A8A3A4E7	89	A8A3A4R164	100	A8A3A8A1MP2	106
A8A3A4H1	89	A8A3A4R165	100	A8A3A8A1MP3	106
A8A3A4H1	89	A8A3A4R166	100	A8A3A8MP1	106
A8A3A4B2	89	A8A3A4R167	100	A8A3A8MP2	106
A8A3A4H1	89	A8A3A4R168	99	A8A3A9	111
A8A3A4H1	89	A8A3A4R169	100	A8A3A9A1	111
A8A3A4H1	89	A8A3A4R170	99	A8A3A9A1C1	112
A8A3A4H1	99	A8A3A4R171	99	A8A3A9A1C10	111
A8A3A4H2	89	A8A3A4R180	100	A8A3A9A1C2	112
ABA3A4H2	89	A8A3A4S10	100	A8A3A9A1C3	112

**SECTION V INDEX-REFERENCE DESIGNATION
CROSS-REFERENCE TO PAGE NUMBER**

REFERENCE DESIGNATION	PAGE NUMBER	REFERENCE DESIGNATION	PAGE NUMBER	REFERENCE DESIGNATION	PAGE NUMBER
A8A3A9A1C4	112	AbA3A9A2C35	113	A8A3A9A3C58	114
A8A3A9A1C5	112	A8A3A9A2C36	113	A8A3A9A3C59	115
A8A3A9A1C6	112	A8A3A9A2C37	113	A8A3A9A3C60	114
A8A3A9A1C7	112	A8A3A9A2C38	113	A8A3A9A3E3	115
A8A3A9A1C8	112	A8A3A9A2C39	113	A8A3A9A3E4	115
A8A3A9A1C9	111	A8A3A9A2C40	113	A8A3A9A3H4	114
A8A3A9ALH4	111	A8A3A9A2E1	114	A8A3A9A3L32	115
A8A3A9A1S1	111	A8A3A9A2E2	114	A8A3A9A3L23	115
A8A3A9A1S1E1	111	A8A3A9A2L17	114	A8A3A9A3L34	115
A8A3A9A1S1E1H1	111	A8A3A9A2L18	114	A8A3A9A3L35	115
A8A3A9A1S1E1H2	111	A8A3A9A2L19	114	A8A3A9A3L36	115
A8A3A9A1S1E1H3	111	A8A3A9APL20	114	A8A3A9A3S3	114
A8A3A9A1S1E1H4	111	A8A3A9A2L21	114	ASA3A9A3S3E1	114
A8A3A9A2	112	A8A3A9A2S2	112	A8A3A9A3S3E1H1	114
A8A3A9A2C11	113	A8A3A9A2S2K1	112	A8A3A9A3S3E1H2	114
A8A3A9A2C12	113	A8A3A9A2S2E1H1	112	A8A3A9A3S3E1H3	114
A8A3A9A2C13	113	A8A3A9A2S2E1H2	112	A8A3A9A3S3E1H4	114
A8A3A9A2C14	113	A8A3A9A2S2E1H3	112	A8A3A9A3S3E2	114
A8A3A9A2C15	113	A8A3A9A251E1H4	112	A8A3A9MP1	112
A8A3A9A2C16	113	A8A3A9A2S2E2	112	A8A3A9MP2	112
A8A3A9A2C17	113	A8A3A9A3	114	A8A3A9MP3	112
A8A3A9A2C18	113	A8A3A9A3C41	115	A8A3A9MP4	132
A8A3A9A2C19	113	A8A3A9A3C42	115	A8A3A9MP5	112
A8A3A9A2C20	113	A8A3A9A3C43	115	A8A3A9MP6	112
A8A3A9A2C21	114	A8A3A9A3C44	114	A8A3A9MP7	112
A8A3A9A2C22	113	ABA3A9A3C45	115	A8A3A9MP8	112
A8A3A9A2C23	113	A8A3A9A3C46	115	A8A3CR7	80
A8A3A9A2C24	113	A8A3A9A3C47	115	A8A3C115	80
A8A3A9A2C25	114	A8A3A9A3C48	115	A8A3C116	80
A8A3A9A2C26	113	A8A3A9A3C49	115	A8A3C117	80
A8A3A9A2C27	113	A8A3A9A3C50	115	A8A3C318	80
A8A3A9A2C78	113	A8A3A9A3C51	115	A8A3C188	80
A8A3A9A2C29	113	A8A3A9A3C52	115	A8A3C189	80
A8A3A9A2C30	113	A8A3A9A3C53	115	A8A3C289	80
A8A3A9A7C31	113	A8A3A9A3C54	114	A8A3C290	80
A8A3A9A2C32	113	A8A3A9A3C55	115	A8A3C291	80
A8A3A9A2C33	113	A8A3A9A3C56	114	A8A3C292	80
A8A3A9A2C34	113	A8A3A9A3C57	115	A8A3C293	80

**SECTION V INDEX-REFERENCE DESIGNATION
CROSS-REFERENCE TO PAGE NUMBER**

REFERENCE DESIGNATION	PAGE NUMBER	REFERENCE DESIGNATION	PAGE NUMBER	REFERENCE DESIGNATION	PAGE NUMBER
A8A3C344	80	A8A3E20	108	A8A3E35H1	110
ABA3E1	83	A8A3E20E1	108	ABA3E35H2	110
A8A3E10	106	A8A3E20E2	108	A8A3E35H3	110
A8A3E10H1	106	A8A3E20H3	108	A8A3E36	110
A8A3E10H2	106	A8A3E21	108	A8A3E36H1	110
A8A3E10H3	106	A8A3E21H1	109	A8A3E36H2	110
A8A3E10H4	106	A8A3E21H2	109	A8A3E36H3	110
A8A3E11	111	A8A3E21H3	109	A8A3E37	110
A8A3E11H1	111	A8A3E22	109	A8A3E37H1	110
A8A3E1H2	111	A8A3E23	109	A8A3E37H2	110
A8A3E12	107	A8A3E24	109	A8A3E37H3	110
A8A3E13	107	A8A3E25	109	A8A3E38	110
A8A3E13H1	107	A8A3E26	109	A8A3E38H1	110
A8A3E13H2	107	A8A3E27	109	A8A3E38E12	110
A8A3E11H3	107	A8A3E28	109	A8A3E38B3	110
A8A3E13H4	107	A8A3E29	109	A8A3E38H4	110
A8A3E14	107	A8A3E3	83	ABA3E385	110
A8A3E15	107	A8A3E30	109	A8A3E39	110
A8A3E15H1	107	A8A3E30H21	109	A8A3E4	83
A8A3E15H2	107	A8A3E30H2	109	A8A3E40	111
A8A3E15H3	107	A8A3E30H3	109	A8A3E41	111
A8A3E15H4	107	A8A3E31	109	A8A3E42	111
A8A3E16	108	A8A3E31H1	109	A8A3E43	111
A8A3E16	108	A8A3E31H2	109	A8A3E44	111
A8A3E16H	108	A8A3E1H3	109	A8A3E45	111
A8A3E17	108	A8A3E32	109	A8A3E45H1	111
A8A3E17H1	108	A8A3E32H1	109	A8A3E45H2	111
A8A3F17H2	108	A8A3E32H2	109	A8A3E46	72
A8A3E17H3	108	A8A3E32H3	109	A8A3E46	111
A8A3E18	108	A8A3E33	109	A8A3E46C246	72
A8A3E18H1	108	A8A3E33H1	109	A8A3E46C247	72
A8A3E18H2	108	ABA3E33H2	110	A8A3E46C268	72
A8A3E18H3	108	A8A3E33H3	110	A8A3E46C269	72
A8A3E19	108	A8A3E34	110	A8A3E46C270	72
A8A3E19H1	108	A8A3E34H1	110	A8A3E46C271	72
A8A3E19H2	108	A8A3E34H2	110	A8A3E46C272	72
A8A3E19H3	108	A8A3E4H3	110	A8A3E46C273	72
A8A3E2	83	A8A3E35	110	A8A3E46C274	73

**SECTION V INDEX-REFERENCE DESIGNATION
CROSS-REFERENCE TO PAGE NUMBER**

REFERENCE DESIGNATION	PAGE NUMBER	REFERENCE DESIGNATION	PAGE NUMBER	REFERENCE DESIGNATION	PAGE NUMBER
A8A3E46C275	72	A8A3ED7C148	74	A8A3E47R141	76
A8A3E46C276	72	A8A3E47C149	74	A8A3E47R142	76
A8A3E46C280	72	A8A3E47C150	74	A8A3E47R143	75
A8A3E46C281	72	A8A3E47C151	74	A8A3E47R144	75
A8A3E46E1	72	A8A3E47C152	74	A8A3E47R145	76
A8A3E46H1	111	A8A3E47C153	74	A8A3E47R149	75
A8A3E46H2	72	A8A3E47C154	74	A8A3E47R24	75
A8A3E46H2	111	A8A3E47C155	74	A8A3E47R25	76
A8A3E46L102	72	A8A3E47C156	74	A8A3E47R26	76
A8A3E46Q16	73	A8A3E47C157	74	A8h3E47R27	76
A8A3E46Q17	73	A8A3E47C158	74	A8A3E47R28	75
A8A3E46Q18	73	A8A3E47C159	74	A8A3E47R29	75
A8A3E46Q19	73	A8A3E47C160	74	A8A3E47R30	75
A8A3E46R119	73	A8A3E47C161	74	A8A3E47R31	76
A8A3E46R120	73	A8A3E47C165	74	A8A3E47R32	75
A8A3E46R121	73	A8A3E47C176	74	A8A3E47R33	76
A8A3E46R122	73	A8A3E47C177	74	A8A3E47R34	75
A8A3E46R123	73	A8A3E47C178	74	A8A3E47H35	76
A8A3E46R124	73	A8A3E47C180	74	A8A3E47R36	75
A8A3E46R125	73	A8A3E47C181	74	A8A3E47R37	75
A8A3E46R126	73	A8A3E47C183	74	A8A3E47R38	76
A8A3E46R127	73	A8A3E47E1	73	A8A3E47R39	76
A8A3E46R128	73	A8A3E47J5	75	A8A3E47R40	76
A8A3E46R129	73	A8A3E47J6	75	A8A3E47R41	75
A8A3E46R130	73	A8A3E47Q12	77	A8A3E47R42	75
A8A3E46R131	73	A8A3E47Q13	77	A8A3E47R43	75
A8A3E46R132	73	A8A3E47Q2	76	A8A3E47R44	76
A8A3E46R133	73	A8A3E47Q3	77	A8A3E47R45	76
A8A3E46R134	73	A8A3E47Q4	77	A8A3E47R46	75
A8A3E46R135	73	A8A3E47Q5	77	A8A3E47R47	75
A8A3E47	73	A8A3E47Q6	77	A8A3E47R48	76
A8A3E47CR5	76	A8A3E47Q7	77	A8A3E47R49	76
A8A3E47CR6	76	A8A3E47Q8	77	A8A3E47R50	75
A8A3E47C142	74	A8A3E47R136	76	A8A3E47R51	75
A8A3E47C143	74	A8A3E47R137	76	A8A3E47P52	76
A8A3E47C144	73	A8A3E47R138	75	A8A3E47R53	76
A8A3E47C145	74	A8A3E47R139	75	A8A3E47R54	75
A8A3E47C147	74	A8A3E47R140	76	A8A3E47R55	75

**SECTION V INDEX-REFERENCE DESIGNATION
CROSS-REFERENCE TO PAGE NUMBER**

REFERENCE DESIGNATION	PAGE NUMBER	REFERENCE DESIGNATION	PAGE NUMBER	REFERENCE DESIGNATION	PAGE NUMBER
A8A3E47R56	76	A8A3E48Q15	88	A8A3E48R87	87
A8A3E47R57	75	A8A3E48Q9	88	A8A3E48R89	86
A8A3E48	85	A8A3E48R146	87	A8A3E48R90	86
A8A3E48CR2	88	A8A3E48R147	87	A8A3E48R91	86
A8A3E48CR3	88	A8A3E48R148	88	A8A3E48R92	87
A8A3E48CR8	88	A8A3E48R148H1	88	A8A3E48R93	87
A8A3E48C162	85	A8A3E48R148H2	88	A8A3E48R94	86
A8A3E48C163	86	A8A3E48R148H3	88	A8A3E48R97	87
A8A3E48C164	86	A8A3E48R148H4	88	A8A3E48T1	88
A8A3E48C166	85	A8A3E48R148H5	88	A8A3E5	83
A8A3E48C167	86	A8A3E48R148H6	88	A8A3E6	83
A8A3E48C168	85	A8A3E48R150	87	A8A3E7	84
A8A3E48C168	85	A8A3E48R150H1	87	A8A3E7E1	84
A8A3E48C168	85	A8A3E48R150H2	87	A8A3E7H2	84
A8A3E48C168	86	A8A3E48R150H3	87	A8A367H3	84
A8A3E48C168	86	A8A3E48R150H4	87	A8A3E7H4	84
A8A3E48C168	86	A8A3E48R150H5	87	A8A3E8	85
A8A3E48C168	86	A8A3E48R150H6	87	A8A3E9	85
A8A3E48C168	86	A8A3E48R190	86	A8A3H1	84
A8A3E48C169	85	A8A3E48R58	86	A8A3H10	105
A8A3E48C170	86	A8A3E48H59	86	A8A3H10	121
A8A3E48C171	85	A8A3E48R61	87	A8A3H11	105
A8A3E48C172	86	A8A3E48R62	87	A8A3H11	121
A8A3E48C173	85	A8A3E48R63	87	A8A3H12	105
A8A3E48C174	85	A8A3E48R64	86	A8A3H12	121
A8A3E48C175	85	A8A3E48R65	87	A8A3H13	105
A8A3E48C179	85	A8A3E48R66	86	A8A3H13	121
A8A3E48C182	85	A8A3E48R67	86	A8A3H14	105
A8A3E48C18L	85	A8A3E48R68	87	A8A3H14	121
A8A3E48C185	85	A8A3E48R69	87	A8A3H15	105
A8A3E48C186	86	A8A3E48R70	86	A8A3H15	121
A8A3E48E1	85	A8A3E48R71	87	A8A3H16	105
A8A3E48H4	85	A8A3E48R72	87	A8A3H16	121
A8A3E48L101	86	A8A3E48R77	86	A8A3H17	105
A8A3E48L101	86	A8A3E48R78	87	A8A3H17	121
A8A3E48Q10	88	A8A3E48R79	87	A8A3H18	105
A8A3E48Q11	88	A8A3E48R80	87	A8A3H18	121
A8A3F48Q14	88	A8A3E48R81	87	A8A3H19	105

**SECTION V INDEX-REFERENCE DESIGNATION
CROSS-REFERENCE TO PAGE NUMBER**

REFERENCE DESIGNATION	PAGE NUMBER	REFERENCE DESIGNATION	PAGE NUMBER	REFERENCE DESIGNATION	PAGE NUMBER
A8A3H2	84	A8A3MP14H1	81	A8A3MP24H22	102
A8A3H20	105	A8A3MP15	83	A8A3MP24H23	102
A8A3H21	105	A8A3MP15H1	83	A8A3MP24H24	102
A8A3H22	105	A8A3MP15H2	84	A8A3MP24H25	102
A8A3H23	106	A8A3MP15H3	84	A8A3MP24H26	102
A8A3H3	88	A8A3MP15H4	84	A8A3MP24H27	102
A8A3H4	88	A8A3MP15H5	84	A8A3MP24H28	102
A8A3H5	88	A8A3MP15R6	84	A8A3MP24H29	102
A8A3H6	89	A8A3MP15H7	84	A8A3MP24H3	101
A8A3H7	89	A8A3MP15H8	84	A8A3MP24H30	102
A8A3H8	89	A8A3MP16	88	A8A3MP24H31	102
A8A3H9	105	A8A3MP16H1	88	A8A3M.P24H32	102
A8A3H9	121	A8A3MP16H2	88	A8A3MP24H33	102
A8A3L1	81	A8A3MP17	88	A8A3MP24H34	103
A8A3L120	81	A8A3MP17H1	88	A8A3MP24H35	103
A8A3L121	81	A8A3MP17H2	88	A8A3MP24H36	103
A8A3L145	81	A8A3MP18	101	A8A3MP24H4	101
A8A3L145H1	81	A8A3MP19	101	A8A3MP24H5	101
A8A3L145H2	81	A8A3MP2	90	A8A3MP24H6	101
A8A3L145H3	81	A8A3MP20	101	A8A3MP24H7	101
A8A3L2	82	A8A3MP21	101	A8A3MP24H8	101
A8A3L3	82	A8A3MP22	101	A8A3MP24H9	102
A8A3L4	82	A8A3MP23	101	A8A3MP25	103
A8A3L5	82	A8A3MP24	101	A8A3MP25H1	103
A8A3L98	81	A8A3KP24H1	101	A8A3MP25H10	103
A8A3L98H1	81	A8A3MP24H10	102	A8A3MP25H11	103
A8A3L98H2	81	A8A3MP24H11	102	A8A3MP25H12	103
A8A3MP1	80	A8A3MP24H12	102	A8A3MP25H13	103
A8A3MP10	80	A8A3MP24H13	102	A8A3MP25H14	103
A8A3MP11	81	A8A3MP24H14	102	A8A3MP25H15	103
A8A3MP12	81	A8A3MP24H15	102	A8A3MP25H16	103
A8A3MP12	81	A8A3MP24H16	102	A8A3MP25H17	103
A8A3MP12H1	81	A8A3MP24H17	102	A8A3MP25H18	103
A8A3MP12H2	81	A8A3MP24H18	102	A8A3MP25H19	103
A8A3MP13	81	A8A3MP24H19	102	A8A3MP25H2	103
A8A3MP13	81	A8A3MP24H2	101	A8A3MP25H20	103
A8A3MP13H1	81	A8A3MP24H20	102	A8A3MP25H21	103
A8A3MP14	81	A8A3MP24H21	102	A8A31MP25H22	104

**SECTION V INDEX-REFERENCE DESIGNATION
CROSS-REFERENCE TO PAGE NUMBER**

REFERENCE DESIGNATION	PAGE NUMBER	REFERENCE DESIGNATION	PAGE NUMBER	REFERENCE DESIGNATION	PAGE NUMBER
A8A3MP25H23	104	A8A3MP40	121	A8A3P4A2	83
A8A3MP25H3	103	A8A3MP40H1	121	A8A3P4H1	83
A8A3MP25H4	103	A8A3MP40H2	121	A8A3P4H2	83
A8A3MP25H5	103	A8A3MP5	80	A8A3P4H3	83
A8A3MP25H6	103	A8A3MP6	80	A8A3P4H4	83
A8A3MP25H7	103	A8A3MP7	80	A8A3P4H5	83
A8A3MP25H8	103	A8A3MP7H1	80	A8A3H17	105
A8A3MP25H9	103	A8A3MP8	80	A8A3R18	105
A8A3MP26	104	A8A3MP8H1	80	A8A3R181	105
A8A3MP26	104	A8A3MP9	80	A8A3R182	105
A8A3MP26H1	104	A8A3P1	82	A8A3R19	105
A8A3MP26H2	104	A8A3P1A1	83	A8A3R20	105
A8A3MP26H3	104	A8A3P1A2	83	A8A3R82	105
A8A3MP27	104	A8A3P1H1	82	A8A3R88	105
A8A3MP28	104	A8A3P1H2	82	A8A3TB1	77
A8A3MP29	105	A8A3P1H3	82	A8A3TB1C61	77
A8A3MP3	80	A8A3P1H4	82	A8A3TB1C63	77
A8A3MP30	105	A8A3P1H5	82	A8A3TB1C65	77
A8A3MP31	105	A8A3P1H16	82	A8A3TB1C66	77
A8A3MP32	107	A8A3P1H7	82	A8A3TB1E1	77
A8A3MP33	107	A8A3P2	82	A8A3TB1E2	77
A6A3MP34	107	A8A3P2A1	83	A8A3TB1E3	77
A8A3MP35	107	A8A3P2A2	83	A8A3TB1E4	77
A8A3MP36	107	A8A3P2H1	82	A8A3TB1E4H1	78
A8A3MP37	107	A8A3P2H2	82	A8A3TB1E4H2	78
A8A3MP38	107	A8A3P2H3	82	A8A3TB1E4H3	78
A8A3MP38H1	107	A8A3P2H4	82	A8A3TB1E5	78
A8A3MP38H2	107	A8A3P2H5	a2	A8A3TB1E5H1	78
A8A3MP38H3	107	A8A3P3	82	A8A3TB1E5H2	78
A8A3MP38H4	108	A8A3P3A1	83	A8A3TB1E5H3	78
A8A3MP38H5	108	A8A3P3A2	83	A8A3TB1E6	78
A8A3MP38H6	108	A8A3P3H1	82	A8A3TB1E6H1	78
A8A3MP38H7	108	A8A3P3H2	82	A8A3TB1E6H2	78
A8A3MP38H8	108	A8A3P3H3	82	A8A3TB1E6H3	78
A8A3MP39	121	A8A3P3H4	82	A8A3TB1H1	77
A8A3MP39H1	121	A8A3P3H5	82	A8A3TB1H1	77
A8A3MP39H2	121	A8A3P4	82	A8A3TB1H2	77
A8A3MP4	80	A8A3P4A1	83	A8A3TB1R1	77

**SECTION V INDEX-REFERENCE DESIGNATION
CROSS-REFERENCE TO PAGE NUMBER**

REFERENCE DESIGNATION	PAGE NUMBER	REFERENCE DESIGNATION	PAGE NUMBER	REFERENCE DESIGNATION	PAGE NUMBER
A8A3TB1R2	77	A8A3TB1R10	79	A8A4A1H2	140
A8A3TB1R3	77	A8A3TB2R11	79	A8A4A1L102	141
A8A3TB1R5	77	A8A3TB2R13	79	A8A4A1L103	142
A8A3TB1R6	77	A8A3TB2R14	79	A8A4A1L120	141
A8A3TB1V1	78	A8A3TB2R9	79	A8A4A1L121	141
A8A3TB2	78	A8A3TB2V2	80	A8A4A1MP1	141
A8A3TB2C187	78	A8A3XV31	106	A8A4A1MP1H1	141
A8A3T82C89	78	A8A3XV3H1	106	A8A4A1MP1H2	141
A8A3TB2C90	78	A8A3XV3H2	106	A8A4A1MP1H3	141
A8A3TB2C92	78	A8A3XV3H3	106	A8A4A1MP1H4	141
A8A3TB2E1	78	A8A3XV3H4	107	A8A4A1MP1H5	141
A83TB2E27	9	A8A3XV3H5	107	A8A4A1MP1H6	141
A8A3TB2E3	79	A8A3XV3H6	107	A8A4A1MP1H7	141
A8A3TB2E4	79	A8A3V3	121	A8A4A1MP1H8	141
A8A3TB2E4H1	79	A8A3W1	84	A8A4A1R102	142
A8A3TB2E4H2	79	A8A3W2	84	A8A4A1R103	142
A8A3TB2E4H3	79	A8A4	139	A8A4A1R104	142
A83TB2E5	79	A8A4A1	140	A8A4A1R108	142
A8A3TB2E5H1	79	A8A4A1A1	141	A8A4A1R115	142
A8A3TB2E5H2	79	A8A4A1A1H1	141	A8A4A1R116	142
A8A3TB2E5H3	79	A8A4A1A1H2	141	A8A4A1R119	142
A8A3TB2E6	79	A8A4A1A1H4	141	A8A4A11V101	142
A8A3TB2E6H1	79	A8A4A1A1J1	141	A8A4A15	179
A8A3TB2E6-2	79	A8A4A1A1J2	141	A8A4A15CR3	179
A8A3T132E6H3	79	A8A4A1A1J3	141	A8A4A15CR4	179
A8A3TB2E7	79	A8A4A1A1J4	141	A8A4A15CR5	179
A8A3TB2E13	79	A8A4A1A1J5	141	A8A4A15CR6	179
A8A3TB2E8H1	79	A8A4A1CR101	142	A8A4A15E1	179
A8A3TB2E-H2	79	A8A4A1C101	140	A8A4A15H2	179
A8A3TB2E8H3	79	A8A4A1C103	141	A8A4A15H2	179
A8A3-1-B2H1	78	A8A4A1C104	141	A8A4A15H2	179
A8A3-B2H1	78	A8A4A1C125	140	A8A4A15R16	179
A8A3TB2H2	7B	A8A4A1C126	140	A8A4A16	183
A8A3TB2X1	78	A8A4A1C139	140	A8A4A16C105	184
A8A3TB2	78	A8A4A1C140	141	A8A4A16C108	185
A8A3TB2K1-2	78	A8A4A1C141	141	A8A4A16C106H1	185
A8A3TB2K1H3	78	A8A4A1E1	142	A8A4A16C108H2	185
A8A3TB2K1B4	79	A8A4A1H2	140	A8A4A16C109	184

**SECTION V INDEX-REFERENCE DESIGNATION
CROSS-REFERENCE TO PAGE NUMBER**

REFERENCE DESIGNATION	PAGE NUMBER	REFERENCE DESIGNATION	PAGE NUMBER	REFERENCE DESIGNATION	PAGE NUMBER
A8A4A16C109H1	184	A8A4A16C144	184	A8A4A16MP11	186
A8A4A16C109H2	184	A8A4A16E1	183	A8A4A16MP11H1	186
A8A4A16C110	185	A8A4A16E2	186	A8A4A16MP11H2	186
A8A4A16C110H1	185	A8A4A16E3	186	A8A4A16MP2	185
A8A4A16C110H2	185	A8A4A16E3H1	186	A8A4A16MP3	185
A8A4A16C111	184	A8A4A16E3H2	186	A8A4A16MP4	185
A8A4A16C111H1	184	A8A4A16E4	186	A8A4A16MP5	185
A8A4A16C111H2	184	A8A4A16E4H1	186	A8A4A16MP5H1	184
A8A4H16C112	184	A8A4A16E4H2	186	A8A4A16MP6	185
A8A4A16C112H1	184	A8A4A16E5	186	A8A4A16MP6H1	185
A8A4A16C112H2	184	A8A4A16E5H1	186	A8A4A16MP7	185
A8A4A16C113	184	A8A4A16E5H2	186	A8A4A16MP7H1	185
A8A4A16C113H1	185	A8A4A16E6	186	A8A4A16MP7H2	185
A8A4A16C113H2	185	A8A4A16E6H1	187	A8A4A16MP7	H3
A8A4A16C114	185	A8A4A16E6H2	187		185
A8A4A16C114H1	185	A8A4A16E7	187	A8A4A16MP7H4	185
A8A4A16C114H2	185	A8A4A16E7H1	187	A8A4A16MP8	185
A8A4A16C115	183	A8A4A16E7H2	187	A8A4A16MP8H1	186
A8A4A16C115H1	183	A8A4A16E8	187	A8A4A16MP8H2	186
A8A4A16C115H2	183	A8A4A16E8H1	187	A8A4A16MP9	186
A8A4A16C116	183	A8A4A16E8H2	187	A8A4A16MP9H1	186
A8A4A16C116H1	183	A8A4A16E9	187	A8A4A16MP9H2	186
A8A4A16C116H2	183	A8A4A16E9H1	187	A8A4A16S101A	186
A8A4A16C117	183	A8A4A16E9H2	187	A8A4A16S101B	186
A8A4A16C117H1	183	A8A4A16H1	183	A8A4A2	142
A8A4A16C117H2	183	A8A4A16H2	183	A8A4A2H2	142
A8A4A16C118	184	A8A4A16H2	183	A8A4A2H2	142
A8A4A16C118H1	184	A8A4A16H2	183	A8A4A2MP1	142
A8A4A16C118H2	184	A8A4A16H2	183	A8A4A2Mp2	142
A8A4A16C119	184	A8A4A16H2	183	A8A4A2Mp3	143
A8A4A16C119H1	184	A8A4A16H2	183	A8A4A3	156
A8A4A16C119H2	184	A8A4A16H2	183	A8A4A3MP1	156
A8A4A16C120	184	A8A4A16H2	183	A8A4A3MP1H1	156
A8A4A16C120H1	184	A8A4A16H2	183	A8A4A4	157
A8A4A16C120H2	184	A8A4A16L104-R110	186	A8A4A4MP1	157
A8A4A16C121	184	A8A4A16MP1	185	A8A4A4MP1H1	157
A8A4A16C121H1	184	A8A4A16MP10	186	A8A4A5	160
A8A4A16C121H2	184	A8A4A16MP10H1	186		
A8A4A16C124	184	A8A4A16MP10H2	186		

**SECTION V INDEX-REFERENCE DESIGNATION
CROSS-REFERENCE TO PAGE NUMBER**

REFERENCE DESIGNATION	PAGE NUMBER	REFERENCE DESIGNATION	PAGE NUMBER	REFERENCE DESIGNATION	PAGE NUMBER
A8A4A5MP1	160	A8A4A6A2MP6	166	A8A4A6A7A4MP3	170
A8A4A5MP2	160	A8A4A6A3	166	A8A4A6A7H1	170
A8A4A5MP3	160	A8A4A6A3MP1	167	A8A4A6A7H2	170
A8A4A5MP3H1	160	A8A4A6A3MP2	167	A8A4A6A7H3	170
A8A4A6	162	A8A4A6A3MP3	167	A8A4A6A7H3	170
A8A4A6A1	166	A8A4A6A3MP3	167	A8A4A6A7H3	170
A8A4A6A1MP1	166	A8A4A6A4	167	A8A4A6A7H4	170
A8A4A6A1MP2	166	A8A4A6A4MP1	167	A8A4A6A7H5	170
A8A4A6A1MP3	166	A8A4A6A4MP2	167	A8A4A6A7MP1	169
A8A4A6A1MP4	166	A8A4A6A5	167	A8A4A6A7MP10	170
A8A4A6A1MP5	166	A8A4A6A5MP1	167	A8A4A6A7MP10H1	170
A8A4A6A1MP6	166	A8A4A6A5MP111	167	A8A4A6A7MP10H2	170
A8A4A6A10	172	A8A4A6A5MP112	167	A8A4A6A7MP11	170
A8A4A6A10MP1	172	A8A4A6A5MP113	167	A8A4A6A7MP12	170
A8A4A6A10MP2	172	A8A4A6A5MP114	167	A8A4A6A7MP13	170
A8A4A6A10MP3	172	A8A4A6A6	167	A8A4A6A7MP14	170
A8A4A6A11	172	A8A4A6A6MP1	167	A8A4A6A7MP15	170
A8A4A6A11MP1	172	A8A4A6A6MP1H1	167	A8A4A6A7MP16	170
A8A4A6A11MP2	172	A8A4A6A6MP1H2	167	A8A4A6A7MP17	171
A8A4A6A11MP3	172	A8A4A6A6MP1H3	167	A8A4A6A7MP2	169
A8A4A6A12	172	A8A4A6A6MP1H4	166	A8A4A6A7MP3	169
A8A4A6A12H1	172	A8A4A6A7	168	A8A4A6A7MP4	169
A8A4A6A12H5	172	A8A4A6A7A1	169	A8A4A6A7MP5	169
A8A4A6A12H5	172	A8A4A6A7A1MP1	169	A8A4A6A7MP6	169
A8A4A6A12MP1	172	A8A4A6A7A1MP2	169	A8A4A6A7MP6H1	169
A8A4A6A12MP2	172	A8A4A6A7A1MP3	169	A8A4A6A7MP6H2	169
A8A4A6A13	174	A8A4A6A7A1MP4	169	A8A4A6A7MP7	169
A8A4A6A13H1	174	A8A4A6A7A1MP5	169	A8A4A6A7MP7H1	169
A8A4A6A13MP1	174	A8A8A6A7A2	170	A8A4A6A7MP7H2	169
A8A4A6A13MP2	174	A8A4A6A7A2MP1	170	A8A4A6A7MP8	169
A8A4A6A13MP3	174	A8A4A6A7A2MP2	170	A8A4A6A7MP8H1	169
A8A4A6A13MP4	174	A8A4A6A7A3	170	A8A4A6A7MP8H2	169
A8A4A6A2	166	A8A4A6A7A3MP1	170	A8A4A6A7MP9	169
A8A4A6A2MP1	166	A8A4A6A7A3MP2	170	A8A4A6A7MP9R1	169
A8A4A6A2MP2	166	A8A4A6A7A3MP3	170	A8A4A6A7MP9H2	169
A8A4A6A2MP3	166	A8A4A6A7A4	170	A8A4A6A8	171
A8A4A6A2MP4	166	A8A4A6A7A4MP1	170	A8A4A6A8MP1	171
A8A4A6A2MP5	166	A8A4A6A7A4MP2	170	A8A4A6A8MP2	171

**SECTION V INDEX-REFERENCE DESIGNATION
CROSS-REFERENCE TO PAGE NUMBER**

REFERENCE DESIGNATION	PAGE NUMBER	REFERENCE DESIGNATION	PAGE NUMBER	REFERENCE DESIGNATION	PAGE NUMBER
A8A4A6A8MP3	171	A8A4A6H17	174	A8A4A6MP1H8	163
A8A4A6A8MP3H1	171	A8A4A6H2	173	A8A4A6MP1H9	163
A8A4A6A8MP4	172	A8A4A6H3	162	A8A4A6MP10	164
A8A4A6A8MP5	172	A8A4A6H3	162	A8A4A6MP11	164
A8A4A6A8MP6	172	A8A4A6H3	163	A8A4A6MF12	164
A8A4A6A8MP7	172	A8A4A6H3	173	A8A4A6MP13	164
A8A4A6A9	172	A8A4A6H4	173	A8A4A6MP14	164
A8A4A6A9MP1	172	A8A4A6H5	173	A8A4A6MP15	164
A8A4A6A9MP2	172	A8A4A6H6	162	A8A4A6MP16	164
A8A4A6A9MP3	172	A8A4A6H6	163	A8A4A6MP17	164
A8A4A6E1	165	A8A4A6H6	173	A8A4A6MP18	164
A8A4A6E1H1	165	A8A4A6H7	173	A8A4A6MP18H1	164
A8A4A6E1H2	165	A8A4A6H8	173	A8A4A6MP19	164
AsA4A6E2	165	A8A4A6H9	173	A8A4A6MP19H1	164
A8A4A6E2H1	165	A8A4A6H9	173	A8A4A6MP2	164
A8A4A6E2H2	166	A8A4A6MP1	163	A8A4A6MP20	164
A8A4A6E3	172	A8A4A6MP1H1	163	A8A4A6MP20H1	164
A8A4A6E3H1	172	A8A4A6MP1H10	163	A8A4A6MP21	164
A8A4A6E3H2	172	A8A4A6MP1H11	163	A8A4A6MP21H1	165
A8A4A6E3H3	172	A8A4A6MP1H12	163	A8A4A6MP21H2	165
A8A4A6E4	173	A8A4A6MP1H13	163	A8A4A6MP22	165
A8A4A6E4H1	173	A8A4A6MP1H14	163	A8A4A6MP22H1	165
A8A4A6E4H2	173	A8A4A6MP1H15	163	A8A4A6MP22H2	165
A8A4A6E4H3	173	A8A4A6MP1H16	163	A8A4A6MP23	165
A8A4A6E5	174	A8A4A6MP1H17	163	A8A1A6MP23H1	165
A8A4A6E5H1	174	A8A4A6MP1H18	163	A8A4A6MP23H2	165
A8A4A6E5H2	174	A8A4A6MP1H19	163	A8A4A6MP24	165
A8A4A6E5H3	174	A8A4A6MP1H2	163	A8A4A6MP24H1	165
A8A4A6E5H4	174	A8A4A6MP1H20	163	A8A4A6MP24H2	165
A8A4A6E6	174	A8A4A6MP1H21	163	A8A4A6MP25	165
A8A4A6H1	173	A8A4A6MP1H22	163	A8A4A6MP25H1	165
A8A4A6H10	173	A8A4A6MP1H23	164	A8A4A6MP25H2	165
A8A4A6H11	173	A8A4A6MP1H24	164	A8A4A6MP26	165
A8A4A6H12	174	A8A4A6MP1H3	163	A8A4A6MP26H1	165
A8A4A6H13	174	A8A4A6MP1H4	163	A8A4A6MP26H2	165
A8A4A6H14	174	A8A4A6MP1H5	163	A8A4A6MP27	165
A8A4A6H15	174	A8A4A6MP1H6	163	A8A4A6MP27H1	165
A8A4A6H16	174	A8A4A6MP1H7	163	A8A4A6MP27H2	165

**SECTION V INDEX-REFERENCE DESIGNATION
CROSS-REFERENCE TO PAGE NUMBER**

REFERENCE DESIGNATION	PAGE NUMBER	REFERENCE DESIGNATION	PAGE NUMBER	REFERENCE DESIGNATION	PAGE NUMBER
A8A4A6MP28	166	A8A4A6MP48H1	171	A8A4A6MP9	164
A8A4A6MP29	167	A8A4A6MP48H2	171	A8A4A7	178
A8A4A6MP3	164	A8A4A6MP49	171	A8A4A7A1	178
A8A4A6MP30	166	A8A4A6MP49H1	171	A8A4A7A1CR102	178
A8A4A6MP31	166	A8A4A6MP49H2	171	A8A4A7A1CR103	178
A8A4A6MP32	166	A8A4A6MP5	164	A8A4A7A1C106	178
A8A4A6MP33	166	A8A4A6MP50	171	A8A4A7A1C107	178
A8A4A6MP34	166	A8A4A6MP50H1	171	A8A4A7A1E1	178
A8A4A6MP35	166	A8A4A6MP50H2	171	A8A4A7A1H1	178
A8A4A6MP36	167	A8A4A6MP51	171	A8A4A7A1H2	178
A8A4A6MP36H1	167	A8A4A6MP51H1	171	A8A4A7A1R117	178
A8A4A6MP36H2	167	A8A4A6MP51H2	171	A8A4A7A1R117H1	178
A8A4A6MP37	167	A8A4A6MP51H3	171	A8A4A7A1R117H2	178
A8A4A6MP38	167	A8A4A6MP52	171	A8A4A7A1R129	178
A8A4A6MP39	167	A8A4A6MP52H1	171	A8A4A7H1	178
A8A4A6MP4	164	A8A4A6MP53	171	A8A4A7H2	178
A8A4A6MP40	167	A8A4A6MP53H1	171	A8A4A7MP1	178
A8A4A6MP41	168	A8A4A6MP54	171	A8A4A7R105	178
A8A4A6MP42	168	A8A4A6MP54H1	171	A8A4A7R106	178
A8A4A6MP43	168	A8A4A6MP55	173	A8A4A7R107	178
A8A4A6MP44	168	A8A4A6MP55H1	173	A8A4A7R118	178
A8A4A6MP44H1	168	A8A4A6MP55H2	173	A8A4A7R128	178
A8A4A6MP45	168	A8A4A6MP56	173	A8A4A7S103	178
A8A4A6MP46	168	A8A4A6MP56H1	173	A8A4C122	146
A8A4A6MP46H1	168	A8A4A6MP56H2	173	A8A4C122H1	146
A8A4A6MP46H2	168	A8A4A6UP57	173	A8A4C122H2	146
A8A4A6MP46H3	168	A8A4A6MP57H1	173	A8A4C123	145
A8A4A6MP46H4	168	A8A4A6MP57H2	173	A8A4C123H1	145
A8A4A6MP46H5	168	A8A4A6MP58	174	A8A4C123H2	145
A8A4A6MP46H6	168	A8A4A6MP59	174	A8A4C123H3	145
A8A4A6MP47	168	A8A4A6MP6	164	A8A4C123H4	145
A8A4A6MP47H1	168	A8A4A6MP60	174	A8A4C145	146
A8A4A6MP47H2	168	A8A4A6MP61	166	A8A4C146	146
A8A4A6MP47H3	168	A8A4A6MP62	168	A8A4C146H1	146
A8A4A6MP47H4	168	A8A4A6MP63	168	A8A4C146H2	146
A8A4A6MP47H5	168	A8A4A6MP64	168	A8A4C2	145
A8A4A6MP47H6	168	A8A4A6MP7	164	A8A4C20	145
A8A4A6MP48	171	A8A4A6MPB	164	A8A4C21	145

**SECTION V INDEX-REFERENCE DESIGNATION
CROSS-REFERENCE TO PAGE NUMBER**

REFERENCE DESIGNATION	PAGE NUMBER	REFERENCE DESIGNATION	PAGE NUMBER	REFERENCE DESIGNATION	PAGE NUMBER
A8A4C22	145	A8A4MP53H1	190	A8A4E30H4	155
A8A4C23	145	A8A41154	190	A8A4E31	155
A8A4C24	145	A8A4E154H1	190	A8A4E31H1	155
A8A4C25	145	A8A4E16	140	A8A4E31H2	155
A8A4C26	146	A8A4E160	190	A8A4E31H3	155
A8A1C27	146	A8A4E160H1	190	A8A4E31H4	155
A8A4C28	145	A8A4E167	190	A8A4E32	155
A8A4C29	145	A8A4E167H1	190	A8A4E32H1	155
A8A4C29H1	145	A8A4E167H2	191	A8A4E32H2	155
A8A4C29H2	145	A8A4E168	191	A8A4E32H3	155
A8A4C30	145	A8A4E168H1	191	A8A4E32H4	155
A8A1C30H1	146	A8A4E168H2	191	A8A4E33	161
A8A4C30H2	146	A8A4E17	140	A8A4E34	187
A8A4DS1	162	A8A4E18	140	A8A4E35	187
A8A4DS101	162	A8A4E19	140	A8A4E35H1	187
A8A4DS102	162	A8A4E2	191	A8A4E35H2	188
A8A4DS2	162	A8A4E2H1	191	A8A4E35H3	188
A8A4E1	191	A8A4E20	153	A8A4E36	188
A8A4E1H1	191	A8A4E21	153	A8A4E37	188
A8A4E1H2	191	A8A4122	153	A8A4E37H1	188
A8A4E10	140	A8A4123	153	A8A4E37H2	188
A8A4E11	140	A8A4E24	153	A8A4E37H3	188
A8A4E12	140	A8A4E24H1	153	A8A4E37H4	188
A8A4E13	140	A8A4E25	153	A8A4E38	188
A8A4E131	153	A8A4E26	153	A8A4E38H1	188
A8A4E131H1	153	A8A4E27	153	A8A4E38H2	188
A8A4E139	189	A8A4E28	153	A8A4E38H3	188
A8A4E139H1	189	A8A4E29	154	A8A4E38H4	188
A8A4E139H2	189	A8A4129H1	154	A8A4E39	188
A8A4E14	140	A8A4E29H2	154	A8A4E39H1	188
A8A4E15	140	A8A4E29H3	154	A8A4E39H2	188
A8A4E150	190	A8A4E29H4	154	A8A4E39H3	188
A8A4E150H1	190	A8A4E3	191	A8A4E39H4	188
A8A4E151	190	A8A4E3H1	191	A8A4E4	191
A8A4E1S1H1	190	A8A4E30	154	A8A4E4H1	191
A8A4E152	190	A8A4E30H1	154	A8A4E40	188
A8A4E152H1	190	A8A4E30H2	155	A8A4E41	188
A8A4E153	190	A8A4E30H3	155	A8A4E41H1	188

**SECTION V INDEX-REFERENCE DESIGNATION
CROSS-REFERENCE TO PAGE NUMBER**

REFERENCE DESIGNATION	PAGE NUMBER	REFERENCE DESIGNATION	PAGE NUMBER	REFERENCE DESIGNATION	PAGE NUMBER
A8A4E41H2	188	A8A4E8H1	190	A8A4FL2C237	158
A8A4E42	188	A8A4E9	140	A8A4FL2E1	159
A8A4E42H1	188	A8A4FL2	157	A8A4FL2E1H1	159
A8A4E42H2	188	A8A4FL2C201	157	A8A4FL2E1H10	159
A8A4E43	189	A8A4FL2C202	157	A8A4FL2E1H11	159
A8A4E44	189	A8A4FL2C203	157	A8A4FL2E1H12	159
A8A4E45	189	A8A4FL2C204	157	A8A4FL2E1H2	159
A8A4E46	189	A8A4FL2C205	157	A8A4FL2E1MP13	158
A8A4E47	189	A8A4FL2C206	157	A8A4FL2E1H4	159
A8A4E48	189	A8A4FL2C207	157	A8A4FL2E1H5	159
A8A4E49	189	A8A4FL2C208	157	A8A4FL2E1H6	159
A8A4E5	191	A8A4FL2C209	157	A8A4FL2E1H7	159
A8A4E50	189	A8A4FL2C210	157	A8A4FL2E1H8	159
A8A4E51	189	A8A4FL2C211	157	A8A4FL2E1H9	159
A8A4E52	189	A8A4FL2C212	157	A8A4FL2E2	159
A8A4E53	189	A8A4FL2C213	157	A8A4FL2H2	157
A8A4E54	189	A8A4FL2C214	157	A8A4FL2H2	157
A8A4E55	189	A8A4FL2C215	158	A8A4FL2H2	157
A8A4E55H1	189	A8A4FL2C216	158	A8A4FL2H4	157
A8A4E55H2	189	A8A4FL2C217	158	A8A4FL2L201	158
A8A4E55H3	189	A8A4FL2C218	158	A8A4FL2L202	158
A8A4E55H4	189	A8A4FL2C219	158	A8A4FL2L203	158
A8A4E56	189	A8A4FL2C220	158	A8A4FL2L204	158
A8A4E56H1	189	A8A4FL2C221	158	A8A4FL2L205	158
A8A4E56H2	189	A8A4FL2C222	158	A8A4FL2L206	158
A8A4E56H3	190	A8A4FL2C223	158	A8A4FL2L207	159
A8A4E56H4	190	A8A4FL2C224	158	A8A4FL2L208	159
A8A4E57	190	A8A4FL2C225	158	A8A4FL2L209	159
A8A4E57H1	190	A8A4FL2C226	158	A8A4FL2L210	159
A8A4E57H2	190	A8A4FL2C227	158	A8A4FL2L211	159
A8A4E57H3	190	A8A4FL2C229	158	A8A4FL2MP1	159
A8A4E57H4	190	A8A4FL2C230	158	A8A4F1	159
A8A4E58	189	A8A4FL2C231	158	A8A4F2	159
A8A4E59	189	A8A4FL2C232	158	A8A4F3	159
A8A4E6	191	A8A4FL2C233	158	A8A4F4	159
A8A4E7	190	A8A4FL2C234	158	A8A4F5	159
A8A4E7H1	190	A8A4FL2C235	158	A8A4H1	161
A8A4E8	190	A8A4FL2C235	158	A8A4H1	179

**SECTION V INDEX-REFERENCE DESIGNATION
CROSS-REFERENCE TO PAGE NUMBER**

REFERENCE DESIGNATION	PAGE NUMBER	REFERENCE DESIGNATION	PAGE NUMBER	REFERENCE DESIGNATION	PAGE NUMBER
A8A4H10	192	A8A4J10H2	150	A8A4J4H6	152
A8A4H11	192	A8A4J10H3	150	A8A4J5	151
A8A4H12	192	A8A4J10H4	150	A8A4J5A1	154
A8A4H13	192	A8A4J10H5	150	A8A4J5A2	154
A8A4H14	193	A8A4J10H6	150	A8A4J5H1	151
A8A4H15	193	A8A4J11	152	A8A4J5H2	151
A8A4R16	193	A8A4J11A1	154	A8A4J5H3	151
A8A4H17	193	A8A4J11A2	154	A8A4J5H4	151
A8A4H18	193	A8A4J11H1	152	A8A4J5H5	151
A8A4R2	161	A8A4J1H2	152	A8A4J5H6	151
A8A4H2	179	A8A4J11H3	152	A8A4J6	150
A8A4H3	161	A8A4J11H4	152	A8A4J6A1	154
A8A4H3	179	A8A4J11H5	152	A8A4J6A2	154
A8A4H4	161	A8A4J11H6	152	A8A4J6H1	151
A8A4R4	179	A8A4J2	153	A8A4J6H2	151
A8A4H5	140	A8A4J2H1	153	A8A4J6H3	151
A8A4H5	140	A8A4J2H2	153	A8A4J6H4	151
A8A4H5	161	A8A4J2H3	153	A8A4J6H5	151
A8A4H5	179	A8A4J2H4	153	A8A4J6H6	151
A8A4R6	161	A8A4J2H5	153	A8A4J7	151
A8A4H6	179	A8A4J2H6	153	A8A4J7A1	154
A8A4H7	192	A8A4J3	150	A8A4J7A2	154
A8A4H8	192	A8A4J3A2	153	A8A4J7H1	151
A8A4H9	192	A8A4J3R1	150	A8A4J7H2	151
A8A4J1	152	A8A4J3H2	150	A8A4J7H3	151
A8A4J1A1	161	A8A4J3H3	150	A8A4J7H4	151
A8A4J1A2	161	A8A4J3H4	150	A8A4J7H5	151
A8A4J1H1	152	A8A4J3H5	150	A8A4J7H6	151
A8A4J1H2	152	A8A4J3H6	150	A8A4J8	151
A8A4J1H3	152	A8A4J4	152	A8A4J8A1	154
A8A4J1H4	153	A8A4J4A1	153	A8A4J8A2	154
A8A4J1H5	153	A8A4J4A2	154	A8A4J8H1	151
A8A4J1H6	153	A8A4J4A3	154	A8A4J8H2	151
A8A4J10	150	A8A4J4H1	152	A8A4J8H3	151
A8A4J10A1	154	A8A4J4H2	152	A8A4J8H4	151
A8A4J10A2	154	A8A4J4R3	152	A8A4J8H5	151
A8A4J10A3	154	A8A4J4H4	152	A8A4J8H6	151
A8A4J10H1	150	A8A4J4H5	152	A8A4J9	152

**SECTION V INDEX-REFERENCE DESIGNATION
CROSS-REFERENCE TO PAGE NUMBER (Continued)**

REFERENCE DESIGNATION	PAGE NUMBER	REFERENCE DESIGNATION	PAGE NUMBER	REFERENCE DESIGNATION	PAGE NUMBER
A8A4J9AZ	154	A8A4K3H4	176	A8A4LZ09MP8	150
A8A4J9A2	154	A8A4K4	176	A8A4L109W1	150
A8A4J9A3	154	A8A4K4H1	176	A8A4L110	148
A8A4J9H1	152	A8A4K4H2	176	A8A4L110E1	148
A8A4J9H2	152	A8A4K4H3	176	A8A4L110E2	148
A8A4J9H3	152	A8A4K4H4	176	A8A4L110E3	148
A8A4J9H4	152	A8A4K5H5	176	A8A4L110E4	148
A8A4J9H5	152	A8A4K5H1	176	A8A4L110E5	149
A8A4J9H6	152	A8A4K5H2	176	A8A4L110E6	149
A8A4K1	176	A8A4K5H3	176	A8A4L110E7	149
A8A5KIH1	176	A8A4K5H4	177	A8A4L110H1	148
A8A4K1H2	176	A8A4K6H5	175	A8A4L110H2	148
A8A4K1H3	176	A8A4K6H1	175	A8A4L110MP1	148
A8A4K1Y4	176	A8A4K6H2	175	A8A4L110MP2	148
A8A4K101	175	A8A4K6H3	175	A8A4L110MP3	148
A8A4K102	177	A8A4K6H4	175	A8A4L110W1	148
A8A4K102H1	177	A8A4K6H5	175	A8A4L111	147
A8A4K102H2	177	A8A4L1	147	A8A4LI11E1	147
A8A4K102H3	177	A8A4L105	147	A8A4L111Z2	147
A8A4K102H4	177	A8A4L106	147	A8A4L111E3	147
A8A4K102H5	177	A8A4L109	149	A8A4LZ11E4	147
A8A4K102H6	177	A8A4L109A1	149	A8A4L111E5	147
A8A4K103	187	A8A4L109A1	149	A8A4L111E6	147
A8A4K103H1	187	A8A4L109A3HP2	149	A8A4LI11E7	148
A8A4K103H2	187	A8A4L109A1MP3	149	A8A4L111E8	148
A8A4K103H3	187	A8A4L109AZP3HZ	149	A8A4L111H1	147
A8A4K103H4	187	A8A4L109Z1	149	A8A4L1112	147
A8A4K2	175	A8A4L109Z2	149	A8A4L111MP1	147
A8A4K2H1	176	A8A4L109E3	149	A8A4L1112	147
A8A4K2H2	176	A8A4L109Z4	149	A8A4L111MP3	147
A8A4K2H3	176	A8A4L109E5	149	A8A4L11LP4	147
A8A4K2H4	176	A8A4L109Z6	149	A8A4L111H4H1	147
A8A4K2H5	176	A8A4L109E7	149	A8A4L111MP5	148
A8A4K2H6	176	A8A4L109E8	149	A8A4L111MP6	148
A8A4K3	176	A8A4L109MP4	149	A8A4L1111	148
A8A4K3H1	176	A8A4L109MP5	149	A8A4L112	148
A8A4K3H2	176	A8A4L109MP6	149	A8ALL112E1	148
A8A4K3H3	176	A8A4L1097	149	A8A4L112E2	148

**SECTION V INDEX-REFERENCE DESIGNATION
CROSS-REFERENCE TO PAGE NUMBER (Continued)**

REFERENCE DESIGNATION	PAGE NUMBER	REFERENCE DESIGNATION	PAGE NUMBER	REFERENCE DESIGNATION	PAGE NUMBER
A8A4L112E3	148	A8A4MP13H1	144	A8A41MP25H6	155
A8A4L112E4	148	A8A4MP13H2	144	A8A4MP25H7	156
A8A4L112E5	149	A8A4MP14	145	A8A4MP25H8	156
A8A4L112E6	149	A8A4MP14H1	145	A8A4MP25H9	156
A8A4L112E7	149	A8A4MP15	145	A8A4MP26	156
A8A4L112MP1	148	A8A4MP15H1	145	A8A4MP26H1	156
A8A4L112MP2	148	A8A4MY16	145	A8A4MP26H10	156
A8A4L112MP3	148	A8A4MP16H1	145	A8A4MP26H11	156
A8A4L112MP4	149	A8A4MP17	145	A8A4MP26H2	156
A8A4L112MP5	149	A8A4MY17H1	145	A8A4MP26H3	156
A8A4L112W1	149	A8A4MP18	146	A8A4MP26H4	156
A8A4L122	147	A8A4MP18H1	146	A8A4MP26H 5	156
A8A4L123	147	A8A4MP18H2	146	A8A4MP26H6	156
A8A4L2	147	A8A4MP18H3	146	A8A4MP26H7	156
A8A4L3	147	A8A4MP18H4	146	A8A4MP26H8	156
A8A4L4	150	A8A4MP19	146	A8A4MP26H9	156
A8A5L5	147	A8A4MP2	142	A8A4MP27	156
A8A4L6	147	A8A4MP20	146	A8A4MP27H1	156
A8A4MP1	142	A8A4MP21	146	A8A4MP27H2	156
A8A4MP10	143	A8A4MP22	146	A8A4MP27H3	156
A8A4MP10H1	143	A8A4MP22H1	146	A8A4MP27H4	156
A8A4MP10H2	143	A8A4MP22H2	146	A8A4MP28	160
A8A4MP11	143	A8A4MP22H3	146	A8A4HP29	160
A8A4MP11H1	143	A8A4MP23	146	A8A4MP30	142
A8A4MP11H2	143	A8A4MP23H1	146	A8A4MP30	160
A8A4MP12	144	A8A4MP23H2	147	A8A4MP31	160
A8A4MP12H1	144	A8A4MP23H3	147	A8A4MP32	160
A8A4MP12H10	144	A8A4MP24	150	A8A4MP33	160
A8A4MP12H11	144	A8A4MP24H1	150	A8A4MP34	160
A8A4MP12H2	144	A8A4MP24H2	150	A8A4MP35	160
A8A4MP12H3	144	A8A4MP25	155	A8A4MP35H1	160
A8A41MP12H4	144	A8A4MP25H1	155	A8A4MP36	161
A8A4MP12H5	144	A8A4MP25H10	156	A8A4MP36H1	161
A8A4MP12H6	144	A8A4MY25H11	156	A8A4MP36H1	161
A8A4MP12H7	144	A8A4MP25H2	155	A8ALMP36H2	161
A8A4MP12H8	144	A8A4MP25H3	155	A8A4MP36H3	161
A8A4MP12H9	144	A8A4MP25H4	155	A8A4MP36H4	161
A8A4MP13	144	A8A4MP25H5	155	A8A4MP36H5	161

**SECTION V INDEX-REFERENCE DESIGNATION
CROSS-REFERENCE TO PAGE NUMBER (Continued)**

REFERENCE DESIGNATION	PAGE NUMBER	REFERENCE DESIGNATION	PAGE NUMBER	REFERENCE DESIGNATION	PAGE NUMBER
A8A4MP37	161	A8A4MP55H2	175	A8A4MP7	143
A8A4MP38	161	A8A4MP55H3	175	A8A4MP70	180
A8A4MP39	161	A8A4MP55H4	175	A8A4MP70H1	180
A8A4MP4	142	A8A4MP55H5	175	A8A4MP70H2	180
A8A4MP40	161	A8A4MP55H6	175	A8A4MP71	180
A8A4MP41	161	A8A4MP56	175	A8A4MP71H1	180
A8A4MP42	161	A8A4MP57	175	A8A4MP71H2	180
A8A4MP42H1	161	A8A4MP58	175	A8A4MP72	181
A8A4MP42H2	161	A8A4MP59	175	A8A4MP72H1	181
A8A4MP43	102	A8A4MP6	142	A8A4MP72H2	181
A8A4MP43H1	162	A8A4MP60	179	A8A4MP73	181
A8A4MP44	162	A8A4MP61	179	A8A4MP73H1	181
A8A4MP44H1	162	A8A4MP61H1	179	A8A4MP73H2	181
A8A4MP45	162	A8A4MP61H2	179	A8A4MP74	181
A8A4M45H1	162	A8A4MP62	179	A8A4MP74H1	181
A8A4MP45H2	162	A8A4MP62H1	179	A8A4074H2	181
A8A4MP46	162	A8A4MP62H2	179	A8A4MP75	181
A8A4MP46H1	162	A8A4MP63	179	A8A4MP75H1	181
A8A4MP46H2	162	A8A4MP63H1	179	A8A4MP75H2	181
A8A4MP47	162	A8A4MP63H2	180	A8A4MP76	181
A8A4MP48	162	A8A4MP64	180	A8A4MP76H1	181
A8A4MP49	162	A8A4MP64H1	180	A8A4PP76H2	181
A8A4MP5	142	A8A4MP64H2	180	A8A4MP77	181
A8A4MP50	162	A8A4MP65	180	A8A4MP77H1	181
A8A4MP51	162	A8A4MP65H1	180	A8A4MP77H2	181
A8A4MP52	162	A8A4MP65H2	180	A8A4MP78	181
A8A4MP53	174	A8A4MP66	180	A8A4MP78H1	181
A8A4MP53H1	174	A8A4MP66H1	180	A8A4MP78H2	181
A8A4MPS3H2	174	A8A4MP66H2	180	A8A4MP79	181
A8A4MPS3H3	174	A8A4MP67	180	A8A4MP79H1	181
A8A4MP53H4	175	A8A4MP67H1	180	A8A4M79H2	181
A8A4MP54	175	A8A4MP67H2	180	A8A4MP8	143
A8A4MP54H1	175	A8A4MP68	180	A8A4MP80	181
A8A4MP54H2	175	A8A4MP68H1	180	A8A4MP80H1	182
A8A4MP54H3	175	A8A4MP68H2	180	A8A4MP80H2	182
A8A4MP54H4	175	A8A4MP69	180	A8A4MP81	182
A8A4MP55	175	A8A4MP69H1	180	A8A4MP81H1	182
A8A4MP55H1	175	A8A4MP69H2	180	A8A4MP81112	182

**SECTION V INDEX-REFERENCE DESIGNATION
CROSS-REFERENCE TO PAGE NUMBER (Continued)**

REFERENCE DESIGNATION	PAGE NUMBER	REFERENCE DESIGNATION	PAGE NUMBER	REFERENCE DESIGNATION	PAGE NUMBER
ANALMP32	182	A8A4Q2H3	192	A8A4TB1E1	143
A8ALMPP3	182	A8A4Q2H4	192	A8A4TB1H2	143
A8A4MP54	182	A8A4Q2H5	192	A8A4TB1H2	143
A8A4MP85	182	A8A4Q2H6	192	A8A4TB1R1	143
A8A4MP85A	182	A8A4R10	177	A8A4TB1R2	143
A8A4MP66	182	A8A4R11	142	A8A4TB1R3	143
A8ALMP87	182	A8A4R11H1	142	A8A4TB1R4	143
A8A4MP88	182	A8A4R112	177	A8A4TB10	160
A8A4MP89	182	A8A4R113	177	A8A4TB10H1	160
A8A4MP90	143	A8A4R114	177	A8A4TB10H2	160
A8A4MP90	182	A8A4R120	177	A8A4TB4	144
A8A4MP90H1	182	A8A4R121	178	A8A4TB4H1	144
A8A4MP90H2	132	A8A4R121H1	178	A8A4TB4H2	144
A8A4MP91	182	A8A4R121H2	178	A8A4TB4H3	144
A8A4MP91H1	182	A8A4R125	177	A8A4TB4H4	144
A8A4MP91H2	182	A8A4R126	177	A8A4TB4H5	144
A8A4MP92	182	A8A4R127	177	A8A4TB4H6	144
A8A4MP93	182	A8A4R24	177	A8A4TB6	143
A8A4MP94	182	A6A4R25	177	A8A4TB6CR1	144
A8A4MP95	182	A8A4R6	177	A8A4TB6CR2	144
A8A4M101	140	A8A4R8	177	A8A4TB6CR8	144
A8A4M101H1	140	A8A4R8H1	177	A8A4TB6C1	143
A8ALM101H2	140	ANA4R8H2	177	A8A4TB6E1	143
A8ALM101H3	140	A8A4R8H3	177	A8A4TB6H2	143
A8A4M101H4	140	A8A4R8H4	177	A8A4TB6H2	143
A8A4MP1	153	A8A4R9	177	A8A4T36H2	143
A8A4P2	150	A8A4S1	183	A8A4TB6R23	143
A8A4P3	150	A8A4S1H1	183	A8A4TB6R5	143
A8A4Q1	192	A8A4S102	187	A8A4TB8	160
A8A4Q1H1	192	A8A4S102H1	187	A8A4TB8H1	160
A8A4Q1H2	192	A8A4S102H2	187	A8A4TB8H2	160
A8A4Q1H3	192	A3A4S2	187	A8A4TB9	160
A8ALQ1H4	192	A8A4S2H1	187	A8A4TB9H1	160
A8A4Q1H5	192	A8A4S2H2	187	A8A4TB9H2	160
A8A4Q1H6	192	A8A4S3	182	A8A4T1	192
A8A4Q2	192	A8A4S3H1	183	A8A4T1H1	192
A8A4Q2H1	192	A8A4S3H2	183	A8A4T1H2	192
A8A4Q2H2	192	A8A4TB1	143	A8A4T101	155

**SECTION V INDEX-REFERENCE DESIGNATION
CROSS-REFERENCE TO PAGE NUMBER (Continued)**

REFERENCE DESIGNATION	PAGE NUMBER	REFERENCE DESIGNATION	PAGE NUMBER	REFERENCE DESIGNATION	PAGE NUMBER
A8A4T101R1	155	A8A5C26	131	A8A5E1C8	133
A8A4T101R2	155	A8A5C27	131	A8A5E1C9	133
A8A4T101H3	155	A8A5C28	131	A8A5E1E1	133
A8A4T101H4	155	A8A5C29	131	A8A5E1H4	133
A8A4T2	191	A8A5E1	133	A8A5E10	139
A8A4T2H1	191	A8A5E1CR10	134	A8A5E10H1	139
A8A4T2H2	191	A8A5E1CR11	134	A8A5E11	139
A8A4T2R3	191	A8A5E1CR12	134	A8A5E12	131
A8A4T2Rb	191	A8A5E1CRJ3	134	A8A5E13	131
A8A4T3	191	A8A5E1CR14	134	A8A5E14	131
A8A4T3H1	191	A8A5E1CR15	134	A8A5E15	131
A8A4T3H2	191	A8A5E1CR16	134	A8A5E16	131
A8A4T3H3	191	A8A5E1CR17	134	A8A5E17H2	139
A8A4T3H4	191	A8A5E1CR18	134	A8A5E17H3	139
A8A4V101	192	A8A5E1CR19	134	A8A5E18	139
A8A4U1	161	A8A5E1CR20	134	A8A5E18H1	139
A8A4XF1	160	A8A5E1CR21	134	A8A5E18H2	139
A8A4XP2	160	A8A5E1CR22	134	A8A5E2	135
A8A5	131	A8A5E1CR23	134	A8A5E2C2	135
A8A5A1	131	A8A5E1CR24	134	A8A5E2E1	135
A8A5A1R1	131	A8A5E1CR25	135	A8A5EPH4	135
A8A5A1H2	131	A8A5E1CR6	134	A8A5E2R1	135
A8A5A1J1	131	A8A5E1CR7	134	A8A5E2R15	135
A8A5A1J10	131	A8A5E1CR8	134	A8A5E2R16	135
A8A5A1J11	131	A8A5E1CR9	134	A8A5E2R17	135
A8A5A1J2	132	A8A5E1C10	134	A8A5E2R2	135
A8A5A1J3	132	A8A5E1C11	134	A8ASEPR5	135
A8A5A1J4	132	A8A5E1C12	134	A8A5E3	135
A8A5A1J5	132	A8A5E1C13	134	A8A5E3CR1	135
A8A5A1J6	132	A8A5E1C14	134	A8A5E3CR2	135
A8A5A1J7	132	A8A5E1C15	134	A8A5E3CR26	135
A8A5A1J8	132	A8A5E1C18	133	A8A5E3CR27	135
A8A5A1J9	132	A8A5E1C21	133	A8A5E3CR28	135
A8A5C1	131	A8A5E1C3	133	A8A5E3CR29	135
A8A5C16	131	A8A5E1C4	133	A8A5E3C133	135
A8A5C19A	131	A8A5E1C5	133	A8A5E3CR4	135
A8A5C19B	131	A8A5E1C6	133	A8A5E3E1	135
A8A5C25	131	A8A5E1C7	133	A8A5E3H2	135

**SECTION V INDEX-REFERENCE DESIGNATION
CROSS-REFERENCE TO PAGE NUMBER (Continued)**

REFERENCE DESIGNATION	PAGE NUMBER	REFERENCE DESIGNATION	PAGE NUMBER	REFERENCE DESIGNATION	PAGE NUMBER
A8A5E3H2	135	A8A5MP5H3	133	A8A5R7	137
A8A5E3H2	135	A8A5MP5H4	133	A8A5R9	137
A8A5E4	138	A8A5MP6	133	A8A5TB1	136
A8A5E4H1	138	A8A5MP7	133	A8A5TB1CR31	136
A8A5E1H2	138	A8A5MP8	133	A8A5TB1E1	136
A8A5ES	138	A8A5MP9	138	A8A5TB1E1H1	136
A8A5ESH1	138	A8A5MP9H1	138	A8A5TB1E1H2	136
A8A5ESH2	138	A8A5MP9H2	138	A8A5TB1H1	136
A8A5ESH3	138	A8A5P1	132	A8A5TB1F1	136
A8A5E6	138	A8A5PLA1	133	A8A5TB1MP1	136
A8A5E67H4	138	A8A5P1A2	133	A3A5TB1MP2	136
A8A5E7	139	A8A5P1H1	132	A8H5TB1MP3	136
A8A5E7H1	139	A8A5P1H2	132	A8A5TB1Q1	136
A8A5E8	139	A8A5P1H3	132	A8A5TB1Q2	136
A8A5E9	139	A8A5P1H4	132	A8A5TB1Q3	136
A8A5E9H1	139	A8A5P1H5	132	A8A5TB1Q3H1	136
A8A5K1	137	A8A5P1H6	132	A8A5TB1Q3H2	13G
A8A5K1H1	137	A8A5R10	137	A8A5TB1Q3H3	136
A8A5H2	137	A8A5R11	137	A8A5TB1Q34	136
A8A5L1	135	A8A5R12	137	A8A5TB1Q3H	136
A8A5LH1	136	A8A5R14	137	A8A5TB1Q3H6	136
A8A5L1H2	136	A8A5R22	137	A8A5TB1Q3H7	137
A8A5MP1	131	A8A5R22H1	137	A8A5TB1Q3H8	137
A8A5MP2	132	A8A5R22H2	137	A8A5TB1R19	136
A8A5MP2H1	132	A8A5R22H3	137	A8A5TB1R20	136
A8A5MP2H2	132	A8A5R22S4	137	A8A5TB1R21	136
A8A5MP3	132	A8A5R24	137	A8A5TB1P23	136
A8A5MP3H1	132	A8A5R3	137	A8A5T1	139
A8A5MP3H2	132	A8A5R3R1	137	A8AT1H1	139
A8A5MP3H3	132	A8A5R3H2	137	A8A5T12	139
A8A5MP3H4	132	A8A5R3H3	137	A8A5T1H3	139
A8A5MP3H5	132	A8A5R3H4	137	A8A5T1H4	139
A8A5MP4	133	A8A5R4	137	A8AST2	139
A8A5MP4H1	133	A8A5R4H1	137	A8A5T2H1	139
A8A5MP4H2	133	A8A5R4H2	138	A8A5T2H2	139
A8A5MPS	133	A8A5R4H3	138	A8A5T2H3	139
A8A5MP5H1	133	A8A5R4H4	138	A8A5T2H4	139
A8A5MP5H2	133	A8A5R6	137	A8A5T2H	139

**SECTION V INDEX-REFERENCE DESIGNATION
CROSS-REFERENCE TO PAGE NUMBER (Continued)**

REFERENCE DESIGNATION	PAGE NUMBER	REFERENCE DESIGNATION	PAGE NUMBER	REFERENCE DESIGNATION	PAGE NUMBER
A8A5W1	132	A8A6A1E3	70	A8A6C14	53
ANA1XC19	138	A8A6A1E3H1	70	A8A6C14	54
A8ASXC19H1	138	A8A6A1E3H2	70	A8A6C14	54
A8A5XC19H2	138	A8A6A1E4	70	A8A6C14	54
A8PSXC19H3	138	A8A6A1E4H1	70	A8A6C14	54
A8A5XC19H4	138	A8A6A1E4H2	70	A8A6C14	54
A8ASXC20	138	A8A6A1E5	70	A8A6C14	55
A8A5XC20H1	138	A8A6A1E5H1	70	A8A6C14	55
A8A5XC20H2	138	A8A6A1E5H2	70	A8A6C14	55
A8A5XC20H3	138	A8A6A1H1	69	A8A6C11	55
A8A5XC20H4	138	A8A6A1H2	69	A8A6C14	55
A8A6	52	A8A6A1H3	69	A8A6C14	56
A8A6A1	68	A8A6A1H4	69	A8A6C14	56
A8A6A1A1	69	A8A6A113	69	A8A6C14	56
A8A6A1A1J1	69	A8A6A114	69	A8A6C14	56
A8A6A1A1J2	69	A8A6A115	69	A8A6C14	56
A8A6A1A1J3	69	A8A6A116	69	A8A6C14	57
A8A6A1A1J4	69	A8A6A1Q4	70	A8A6C14	57
A8A6A1C13	68	A8A6A1Q5	70	A8A6C14	57
A8A6A1C15	68	A8A6A1Q6	70	A8A6C14	57
A8A6A1C16	68	A8A6A1R23	69	A8A6C14	57
A8A6A1C17	68	A8A6A1R24	69	A8A6C14	58
A8A6A1C18	68	A8A6A1R25	69	A8A6C14	58
A8A6A1C19	68	A3A6A1R26	69	A8A6C14	58
A8A6A1C21	68	A8A6A1R27	69	A8A6C14	58
A8A6A1C22	68	A8A6A1R28	69	A8A6C14	58
A8A6A1C23	68	A8A6A1R29	69	A8A6C14	59
A8A6A1C24	69	A8A6A1R31	69	A8A6C11	59
A8A6A1C26	68	A8A6A1R32	69	A8A6C14	59
A8A6A1C36	68	A8A6A1R33	69	A8A6C14	59
A8A6A1C39	68	A8A6A1R45	69	A8A6C14	59
A8A6A1C40	68	A8A6C14	52	A8A6C14	60
A8A6A1E1	70	A8A6C14	52	A8A6C14	60
A8A6A1E1H1	70	A8A6C11	52	A8A6C14	60
A8A6A1E1H2	70	A8A6C11	53	A8A6C14	60
A8A6A1E2	70	A8A6C14	53	A8A6C11	60
A8A6A1E2H1	70	A8A6C14	53	AdA6C14	61
A8A6A1E2H2	70	A8A6C14	53	A8A6C11	61

**SECTION V INDEX-REFERENCE DESIGNATION
CROSS-REFERENCE TO PAGE NUMBER (Continued)**

REFERENCE DESIGNATION	PAGE NUMBER	REFERENCE DESIGNATION	PAGE NUMBER	REFERENCE DESIGNATION	PAGE NUMBER
A8A6C14	61	A8A6C20	59	A8A6C23	57
A8A6C14	61	A8A6C20	59	A8A6C73	58
A8A6C20	52	A8A6C20	60	A8A6C23	58
A8A6C20	52	A8A6C20	60	A8A6C23	58
A8A6C20	52	A8A6C20	60	A8A6C23	58
A8A6C20	53	A8A6C20	60	A8A6C23	58
A8A6C20	53	A8A6C20	60	A8A6C23	59
A8A6C20	53	A8A6C20	61	A8A6C23	59
A8A6C20	53	A8A6C20	61	A8A6C23	59
A8A6C20	53	A8A6C20	61	A8A6C23	59
A8A6C20	54	A8A6C20	61	A8A6C23	59
A8A6C20	54	A8A6C23	52	A8A6C23	60
A8A6C20	54	A8A6C23	52	A8A6C23	60
A8A6C20	54	A8A6C23	52	A8A6C23	60
A8A6C20	54	A8A6C23	53	A8A6C23	60
A8A6C20	55	A8A6C23	53	A8A6C23	60
A8A6C20	55	A8A6C23	53	A8A6C23	61
A8A6C20	55	A8A6C23	53	A8A6C23	61
A8A6C20	55	A8A6C23	53	A8A6C23	61
A8A6C20	55	A8A6C23	54	A8A6C23	61
A8A6C20	56	A8A6C23	54	A8A6C29	52
A8A6C20	56	A8A6C23	54	A8A6C29	52
A8A6C20	56	A8A6C23	54	A8A6C29	53
A8A6C20	56	A8A6C23	54	A8A6C29	53
A8A6C20	56	A8A6C23	55	A8A6C29	53
A8A6C20	57	A8A6C23	55	A8A6C29	53
A8A6C20	57	A8A6C23	55	A8A6C29	54
A8A6C20	57	A8A6C23	55	A8A6C29	54
A8A6C20	57	A8A6C23	56	A8A6C29	54
A8A6C20	58	A8A6C23	56	A8A6C29	54
A8A6C20	58	A8A6C23	56	A8A6C29	55
A8A6C20	58	A8A6C23	56	A8A6C29	55
A8A6C20	58	A8A6C23	57	A8A6C29	55
A8A6C20	58	A8A6C23	57	A8A6C29	55
A8A6C20	59	A8A6C23	57	A8A6C29	55
A8A6C20	59	A8A6C23	57	A8A6C29	55
A8A6C20	59	A8A6C23	57	A8A6C29	56

**SECTION V INDEX-REFERENCE DESIGNATION
CROSS-REFERENCE TO PAGE NUMBER (Continued)**

REFERENCE DESIGNATION	PAGE NUMBER	REFERENCE DESIGNATION	PAGE NUMBER	REFERENCE DESIGNATION	PAGE NUMBER
A8A6C29	56	A8A6C34	54	A8A6E1	62
A8A6C29	56	A8A6C34	54	A8A6E1C27	63
A8A6C29	56	A8A6C34	54	A8A6E1C28	62
A8A6C29	56	A8A6C34	55	A8A6E1C30	62
A8A6C29	57	A8A6C34	55	A8A6E1C31	62
A8A6C29	57	A8A6C34	55	A8A6E1C32	62
A8A6C29	57	A8A6C34	55	A8A6E1C33	62
A8A6C29	57	A8A6C34	55	A8A6E1C35	62
A8A6C29	57	A8A6C34	56	A8A6E1C37	62
A8A6C29	58	A8A6C34	56	A8A6E1C38	62
A8A6C29	58	A8A6C34	56	A8A6E1P1	63
A8A6C29	58	A8A6C34	56	A8A6E1E1HE	63
A8A6C29	58	A8A6C34	56	A8A6E1E1H2	63
A8A6C29	58	A8A6C34	57	A8A6E1E2	63
A8A6C29	59	A8A6C34	57	A8A6E1E2H1	63
A8A6C29	59	A8A6C34	57	A8A6E1E2H2	63
A8A6C29	59	A8A6C34	57	A8A6E1E3	63
A8A6C29	59	A8A6C34	57	A8A6E1E3HU	64
A8A6C29	59	A8A6C34	58	A8A6E1E3H2	64
A8A6C29	60	A8A6C34	58	A8A6E1E4	64
A8A6C29	60	A8A6C34	58	A8A6E1E4H1	64
A8A6C29	60	A8A6C34	58	A8A6E1E4H2	64
A8A6C29	60	A8A6C34	58	A8A6E1E5	64
A8A6C29	60	A8A6C34	59	A8A6E1E5H1	64
A8A6C29	61	A8A6C34	59	A8A6E1E5H2	64
A8A6C29	61	A8A6C34	59	A8A6E1E6	64
A8A6C29	61	A8A6C34	59	A8A6E1E6HU	64
A8A6C29	61	A8A6C34	59	A8A6E1E6E2	64
A8A6C29	61	A8A6C34	60	A8A6E1H1	63
A8A6C34	52	A8A6C34	60	A8A6E1H2	63
A8A6C34	52	A8A6C34	60	A8A6E1H3	63
A8A6C34	53	A8A6C34	60	A8A6E1H6	62
A8A6C34	53	A8A6C34	60	A8A6E1H6	62
A8A6C34	53	A8A6C34	61	A8A6E1L7	63
A8A6C34	53	A8A6C34	61	A8A6E1L8	63
A8A6C34	53	A8A6C34	61	A8A6E1L9	63
A8A6C34	54	A8A6C34	61	A8A6E1Q7	64
A8A6C34	54	A8A6C34	61	A8A6E1Q8	64

**SECTION V INDEX-REFERENCE DESIGNATION
CROSS-REFERENCE TO PAGE NUMBER (Continued)**

REFERENCE DESIGNATION	PAGE NUMBER	REFERENCE DESIGNATION	PAGE NUMBER	REFERENCE DESIGNATION	PAGE NUMBER
A8A6E1Q9	64	A8A6E2C13	66	A8A6E2R1H1	67
A8A6E1R34	63	A8A6E2C13	66	A8A6E2R1H2	67
A8A6E1R35	63	A8A6E2C13	66	A8A6E2R1H3	67
A8A6E1R36	63	A8A6E2C13	66	A8A6E2R1H4	67
A8A6E1R37	63	A8A6E2C2	64	A8A6E2R10	67
A8A6E1R38	63	A8A6E2C3	64	A8A6E2R11	67
A8A6E1R39	63	A8A6E2C4	64	A8A6E2R12	67
A8A6E1R40	63	A8A6E2C5	64	A8A6E2R13	66
A8A6E1R41	63	A8A6E2C6	64	A8A6E2R14	67
A8A6E1R42	63	A8A6E2C7	64	A8A6E2R15	67
A8A6E1R43	63	A8A6E2C8	64	A8A6E2R16	67
A8A6E1R44	63	A8A6E2C9	65	A8A6E2R17	66
A8A6E1TB1	62	A8A6E2C9	65	A8A6E2R18	67
A8A6E2	64	A8A6E2C9	65	A8A6E2R18	67
A8A6E2A1	66	A8A6E2C9	65	A8A6E2R18	67
A8A6E2CR1	68	A8A6E2C9	65	A8A6E2R18	67
A8A6E2CR2	68	A8A6E2C9	65	A8A6E2R18	67
A8A6E2C1	66	A8A6E2C9	65	A8A6E2R2	60
A8A6E2C10	65	A8A6E2C9	65	A8A6E2R2H1	68
A8A6E2C11	64	A8A6E2C9	65	A8A6E2R2H2	68
A8A6E2C12	66	A8A6E2C9	65	A8A6E2R2H3	68
A8A6E2C13	65	A8A6E2C9	65	A8A6E2R2H4	68
A8A6E2C13	65	A8A6E2C9	65	A8A6E2R3	68
A8A6E2C13	65	A8A6E2C9	66	A8A6E2R4	67
A8A6E2C13	65	A8A6E2C9	66	A8A6E2R4	67
A8A6E2C13	65	A8A6E2C9	66	A8A6E2R4	67
A8A6E2C13	65	A8A6E2C9	66	A8A6E2R4	67
A8A6E2C13	65	A8A6E2C9	66	A8A6E2R5	67
A8A6E2C13	65	A8A6E2C9	66	A8A6E2R6	67
A8A6E2C13	65	A8A6E2C9	66	A&A6E2R7	67
A8A6E2C13	65	A8A6E2C9	66	A8A6E2R8	67
A8A6E2C13	65	A8A6E2C9	66	A8A6E2R9	67
A8A6E2C13	66	A8A6E2L1	66	A8A6E2TB1	64
A8A6E2C13	66	A8A6E2L2	66	A8A6E3	72
A8A6E2C13	66	A8A6E2Q1	68	A8A6MP1	52
A8A6E2C13	66	A8A6E2Q2	68	A8A6MP2	62
A8A6E2C13	66	A8A6E2Q3	68	A8A6MP2H1	62
A8A6E2C13	66	A8A6E2R1	67	A8A6MP2H2	62

**SECTION V INDEX-REFERENCE DESIGNATION
CROSS-REFERENCE TO PAGE NUMBER (Continued)**

REFERENCE DESIGNATION	PAGE NUMBER	REFERENCE DESIGNATION	PAGE NUMBER	REFERENCE DESIGNATION	PAGE NUMBER
A8A6MP2H3	62	A8A6R45	72	A8A7A1A3H2	30
A8A6MP2H4	62	A8A6R45	72	A8A7A1A3H2	30
A8A6MP3	64	A8A6R46	70	A8A7A1A3H2	30
A8A6P1	61	A8A6R46	70	A8A7A1A3H3	30
A8A6P1A1	62	A8A6R46	71	A8A7A1A3H4	30
A8A6P1A2	62	A8A6R46	71	A8A7A1A3MP1	30
A8A6P1A3	62	A8A6R46	71	A8A7A1A3MP3	30
A8A6P1H1	61	A8A6R46	71	A8A7A1A4	30
A8A6P1H2	61	A8A6R46	71	A8A7A1A4H1	30
A8A6P1H3	62	A8A6R46	71	A8A7A1A4H2	30
A8A6P1H4	62	A8A6R46	71	A8A7A1A4H3	30
A8A6P1H5	62	A8A6R46	71	A8A7A1A4MP1	30
A8A6P1H6	62	A8A6R46	72	A8A7A1A4MF2	30
A8A6P1H7	62	A8A6R46	72	A8A7A1A4MP3	30
A8A6R30	70	A8A6R46	72	A8A7A1H6	29
A8A6R30	70	A8A7	13	A8A7A2	44
A8A6R30	70	A8A7A1	29	A8A7A2A1	44
A8A6R30	71	A8A7A1A1	29	A8A7A2A1MP1	44
45A6R30	71	A8A7A1A1MP1	29	A8A7A2A1MP2	44
A8A6R30	71	A8A7A1A1KP2	29	A8A7A2A1MP3	44
A8A6R30	71	A8A7A1A2	29	A8A7A2MP1	44
A8A6R30	71	A8A7A1A2MP1	29	A8A7A2MP2	44
A8A6R30	71	A8A7A1A2MP10	30	A8A7A3	45
A8A6R30	71	A8A7A1A2MP2	29	A8A7A3A1	45
A8A6R30	71	A8A7A1A2MP3	29	A8A7A3A1MP1	45
A8A6R30	72	A8A7A1A2MP4	29	A8A7A3A1MP2	45
A8A6R30	72	A8A7A1A2MP5	29	A8A7A3A1MP3	45
A8A6R45	70	A8A [A1A2MP6	29	A8A7A3MP1	45
A8A6R45	70	A8A7A1A2MP7	30	A8A7A3MP2	45
A8AbR45	71	A8A7A1A2MP8	30	A8A7C181	15
A8A6R45	71	A8A7A1A2MP9	30	A8A7C182	15
A8A6R45	71	A8A7A1A3A	30	A8A7C183	15
A8A6R45	71	A8A7A1A3A1	30	A8A7C184	15
A8A6R45	71	A8A7A1A3A1MP1	30	A8A7E1	31
A8A6R45	71	A8A7A1A3A1MP2	30	A8A7E1CR1	33
A8A6R45	71	A8A7A1A3H1	30	A8A7E1C1	31
A8A6R45	71	A8A7A1A3H1	30	A8A7E1C10	31
A8A6R45	71	A8A7A1A3H1	30	A8A7E1C11	31

**SECTION V INDEX-REFERENCE DESIGNATION
CROSS-REFERENCE TO PAGE NUMBER (Continued)**

REFERENCE DESIGNATION	PAGE NUMBER	REFERENCE DESIGNATION	PAGE NUMBER	REFERENCE DESIGNATION	PAGE NUMBER
A8A7E1C12	31	A8A7E1R21	33	A8A7E2C29	26
A8A7E1C13	31	A8A7E1R22	32	A8A7E2C30	26
A8A7E1C14	31	A8A7E1R23	32	A8A7E2C32	26
A8A7E1C15	31	A8A7E1R24	32	ABATE2C33	26
A8A7E1C157	31	A8A7E1R25	32	A8A7E2C34	26
A8A7E1C16	31	A8A7E1R26	32	A8A7E2C35	26
A8A7E1C18	31	A8A7E1R27	32	A8A7E2C36	26
A8A7E1C19	31	A8A7E1R28	32	A8A7E2C92	26
A8A7E1C2	31	A8A7E1R29	32	A8A7E2C93	26
A8A7E1C3	31	A8A7E1R3	32	A8A7E2E2	26
A8A7E1C4	31	A8A7E1R30	32	A8A7E2J5	27
A8A7E1Cs	31	A8A7E1R3I	32	A8A7E2J6	27
A8A7E1C7	31	A8A7E1R4	32	A8A7E2L3	27
A8A7E1C8	31	A8A7E1R5	32	A8A7E2L4	27
A8A7E1C9	31	A8A7E1R6	32	A8A7E2L5	27
A8A7E1E1	31	A8A7E1R7	32	A8A7E2L6	27
A8A7E1L1	31	A8A7E1R8	31	A8A7E2L7	27
A8A7E1L2	31	A8A7E1R9	32	A8ATE2I8	27
A8A7E1Q1	33	A8A7E2	26	A8A7E2MP1	27
A8A7E1Q2	33	A8A7E2CR16	29	A8A7E2MP2	27
A8A7E1Q3	33	A8A792CR17	29	A8A7E2Q11	29
A8A7E1Q4	33	A8A7E2CR3	29	A8A7E2Q13	29
A8A7E1Q5	33	A8A7E2CR4	29	A8A7E2Q9	29
A8A7E1Q6	33	A8A7E2C200	27	A8A7E2R103	27
A8A7E1Q7	33	A8A7E2C200	27	A8A7E2R104	28
A8ATF1R1	33	A8A7E2C200	27	A8A7E2R32	28
A8A7E1R10	33	A8A7E2C200	27	A8A7E2R33	28
A8A7E1R11	32	A8A7E2C201	27	A8A7E2R34	28
A8A7E1R12	32	A8A7E2C201	27	A8A7E2R35	28
A8A7E1R13	32	A8A7E2C201	27	A8A7E2R36	28
A8A7E1R14	32	A8A7E2C201	27	A8ATE2R37	28
A8A7E1R15	31	A8A7E2C21	27	A8A7E2R38	28
A8A7E1R16	32	A8A7E2C22	26	A8A7E2R39	27
A8A7E1R17	32	A8A7E2C23	26	AoA7E2R40	28
A8A7E1R18	32	A8A7E2C25	26	A8A7E2R41	28
A8A7E1R19	32	A8A7E2CP6	26	A8A7E2R42	28
A8A7E1R20	32	A8A7E2C27	26	A8A7E2R44	29
A8A7E1R20	31	A8A7E2C28	26	A8A7E2H45	27

**SECTION V INDEX-REFERENCE DESIGNATION
CROSS-REFERENCE TO PAGE NUMBER (Continued)**

REFERENCE DESIGNATION	PAGE NUMBER	REFERENCE DESIGNATION	PAGE NUMBER	REFERENCE DESIGNATION	PAGE NUMBER
A8A7E2R46	28	A8A7E4L16	14	A8A7E5C9	40
A8A7E2R47	29	A8A7E4L17	14	A8A7E5C80	41
A8A7E2R48	29	A8A7E4118	14	A8A7E5C80H1	41
A8A7E2R49	28	A8A7E4Q17	15	A8A7E5C80H2	41
A8A7E2R50	27	A8A7E4Q18	15	A8A7E5C81	40
A8A7E2R51	28	A8A7E4Q19	15	A8A7E5C82	41
A8A7E2R53	28	A8A7E4R100	15	A8A7E5C82H1	41
A8A7E2R54	28	A8A7E4R101	14	A8A7E5C82H2	41
A8A7E2R55	28	A8A7E4R102	14	A8A7E5C83	40
A8A7E2R56	28	A8A7E4R88	14	A8A7E5C84	41
A8A7E2R57	28	A8A7E4R89	15	A8A7E5C84H1	41
A8A7E2R58	28	A8A7E4R90	14	A8A7E5C84H2	41
A8A7E2R59	27	A8A7E4R91	14	A8A7E5C85	40
A8A7E2R60	28	A8A7E4R92	14	A8A7E5C86	41
A8A7E2R61	28	A8A7E4R93	14	A8A7E5C86H1	41
A8A7E2R62	28	A8A7E4R94	15	A8A7E5C86H2	41
A8A7E2R64	29	A8A7E4R95	14	A8A7E5C87	40
A8A7E2R65	28	A8A7E4R96	14	A8A7E5C88	41
A8A7E2R66	29	A8A7E4R97	14	A8A7E5C88H1	41
A8A7E2R67	29	A8A7E4R98	15	A8A7E5C88H2	41
A8A7E2R68	28	A8A7E4R99	14	A8A7E5C89	40
A8A7E2R69	27	A8A7E5	39	A8A7E5C90	41
A8A7E4	13	A8A7E5C71	40	A8A7E5C90H1	41
A8A7E4C56	14	A8A7E5C72	40	A8A7ESC90H2	42
A8A7E4C57	13	A8A7E5C72H1	40	A8A7E5C91	40
A8A7E4C58	14	A8A7E5C72H2	40	A8A7ESE1	40
A8A7E4C59	13	A8A7E5C73	40	A8A7E5E1H1	40
A8A7E4C60	13	A8A7E5C74	40	A8A7E5EEH2	40
A8A7E4C61	14	A8A7E5C74H1	41	A8A7E5E1H3	40
A8A7E4C62	14	A8A7E5C74H2	41	A8A7E5E1H4	40
A8A7E4C63	14	A8A7E5C75	40	A8A7E5E2	42
A8A7E4C65	14	A8A7E5C76	41	A8A7E5E2H1	42
A8A7E4C66	14	A8A7E5C76H1	41	A8A7E5E2H2	42
A8A7E4C67	14	A8A7E5C76H2	41	A8A7E5E2H3	42
A8A7E4C68	14	A8A7E5C77	40	A8A7E5E2H4	42
A8A7E4C69	14	A8A7E5C78	41	A8A7E5E2H5	42
A8A7E4C70	14	A8A7E5C78H1	41	A8A7E5E2H6	42
A8A7E4E1	13	A8A7E5C78H2	41	A8A7E5E2H7	42

**SECTION V INDEX-REFERENCE DESIGNATION
CROSS-REFERENCE TO PAGE NUMBER (Continued)**

REFERENCE DESIGNATION	PAGE NUMBER	REFERENCE DESIGNATION	PAGE NUMBER	REFERENCE DESIGNATION	PAGE NUMBER
A8A7E5E2H8	42	A8A7E6L21	24	A8A7E7A1C118	17
A8A7E5E3	42	A8A7E6L22	24	A8A7E7A1C118	18
A8A7E5E4	42	A8A7E6L23	24	A8A7E7A1C118	19
A8A7E5H4	40	A8A7E6L24	24	A8A7E7A1C118	19
A8A7E5H4	40	A8A7E6L25	24	A8A7E7A1C120	16
A8A7E5H4	40	A8A7E6L26	24	A8A7E7A1C120	17
A8A7E5L19	42	A8A7E6MP1	24	A8A7E7A1C120	14
A8A7E5MP1	40	A8A7E6Q20	25	A8A7E7A1C120	19
A8A7E5MP2	40	A8A7E6Q21	25	A8A7E7A1C120	20
A8A7E5MP3	42	A8A7E6Q22	25	A8A7E7A1C122	16
A8A7E5MP3H1	42	A8A7E6Q23	25	A8A7E7A1C122	17
A8A7E5MP4	42	A8A7E6R105	24	A8A7E7A1C122	14
A8A7E5MP5	42	A8A7E6R106	24	A8A7E7A16122	19
A8A7E5MP6	42	A8A7E6R107	24	A8A7E7A1C122	20
A8A7E6	23	A8A7E6R108	24	A8A7E7A1C124	16
A8A7E6CR7	24	A8A7E6R109	24	A8A7E7A1C124	17
A8A7E6CR8	25	A8A7E6R110	24	A8A7E7A1C124	14
A8A7E6C100	23	A8A7E6R111	24	A8A7E7A1C124	19
A8A7E6C101	23	A8A7E6R112	24	A8A7E7A1C124	20
A8A7E6C102	23	A8A7E6R113	24	A8A7E7A1C126	16
A8A7E6C103	23	A8A7E6R114	24	A8A7E7A1C126	17
A8A7E6C104	23	A8A7E6R115	24	A8A7E7A1C126	14
A8A7E6C105	23	A8A7E6R116	24	A8A7E7A1C126	19
A8A7E6C106	23	A8A7E6R117	24	A8A7E7A1C126	20
A8A7E6C107	23	A8A7E6R118	24	A8A7E7A1C128	16
A8A7E6C108	23	A8A7E7	16	A8A7E7A1C128	17
A8A7E6C109	23	A8A7E7A1	16	A8A7E7A1C128	14
A8A7E6C111	23	A8A7E7A1C114	16	A8A7E7A1C128	19
A8A7E6C112	23	A8A7E7A1C114	17	A8A7E7A1C128	30
A8A7E6C156	24	A8A7E7A1C114	14	A8A7E7A1C130	17
A8A7E6C94	23	A8A7E7A1C114	19	A8A7E7A1C130	17
A8A7E6C95	24	A8A7E7A1C114	19	A8A7E7A1C130	14
A8A7E6C96	23	A8A7E7A1C116	16	A8A7E7A1C130	19
A8A7E6C97	23	A8A7E7A1C116	17	A8A7E7A1C130	20
A8A7E6C98	23	A8A7E7A1C116	14	A8A7E7A1C132	17
A8A7E6C99	23	A8A7E7A1C116	19	A8A7E7A1C132	17
A8A7E6E1	23	A8A7E7A1C116	19	A8A7E7A1C132	14
A8A7E6J1	24	A8A7E7A1C118	16	A8A7E7A1C132	19

**SECTION V INDEX-REFERENCE DESIGNATION
CROSS-REFERENCE TO PAGE NUMBER (Continued)**

REFERENCE DESIGNATION	PAGE NUMBER	REFERENCE DESIGNATION	PAGE NUMBER	REFERENCE DESIGNATION	PAGE NUMBER
A8A7E7A1C132	20	A8A7E7A1C148	18	A8A7E7A2E1	20
A8A7E7A1C134	17	A8A7E7A1C148	19	A8A7E7A2E1	21
A8A7E7A1C134	17	A8A7E7A1C148	20	A8A7E7A2E1H1	21
A8A7E7A1C134	14	A8A7E7A1C150	17	A8A7E7A2E1H2	21
A8A7E7A1C134	19	A8A7E7A1C150	14	A8A7E7A2E1H3	21
A8A7E7A1C134	20	A8A7E7A1C150	19	A8A7E7A2E1H4	21
A8A7E7A1C136	17	A8A7E7A1C150	19	A8A7E7A2E2	21
A8A7E7A1C136	17	A8A7E7A1C150	20	A8A7E7A2E2H1	21
A8A7E7A1C136	14	A8A7E7A1C152	17	A8A7E7A2E2H2	21
A8A7E7A1C136	19	A8A7E7A1C152	14	A8A7E7A2E2H3	21
A8A7E7A1C136	20	A8A7E7A1C152	19	A8A7E7A2E2H4	21
A8A7E7A1C138	17	A8A7E7A1C152	19	A8A7E7A2E3	21
A8A7E7A1C138	17	A8A7E7A1C152	20	A8A7E7A2E4	22
A8A7E7A1C138	14	A8A7E7A1E8	16	A8A7E7A2MP1	22
A8A7E7A1C138	19	A8A7E7A1H2	16	A8A7E7A2MP10	23
A8A7E7A1C138	20	A8A7E7A1H2	16	A8A7E7A2MP2	22
A8A7E7A1C140	17	A8A7E7A1H4	16	A8A7E7A2MP3	22
A8A7E7A1C140	14	A8A7E7A2	20	A8A7E7A2MP4	22
A8A7E7A1C140	14	A8A7E7A2C113	20	A8A7E7A2MP5	23
A8A7E7A1C140	19	A8A7E7A2C115	20	A8A7E7A2MP6	23
A8A7E7A1C140	20	A8A7E7A2C117	20	A8A7E7A2MP7	23
A8A7E7A1C142	17	A8A7E7A2C119	20	A8A7E7A2MP8	23
A8A7E7A1C142	14	A8A7E7A2C121	20	A8A7E7A2MP9	23
A8A7E7A1C142	14	A8A7E7A2C123	20	A8A7E7A2Y1	22
A8A7E7A1C142	19	A8A7E7A2C125	21	A8A7E7A2Y10	22
A8A7E7A1C142	20	A8A7E7A2C127	21	A8A7E7A2Y11	22
A8A7E7A1C144	17	A8A7E7A2C129	21	A8A7E7A2Y12	22
A8A7E7A1C144	14	A8A7E7A2C131	21	A8A7E7A2Y13	22
A8A7E7A1C144	14	A8A7E7A2C133	21	A8A7E7A2Y14	22
A8A7E7A1C144	19	A8A7E7A2C135	21	A8A7E7A2Y15	22
A8A7E7A1C144	20	A8A7E7A2C137	21	A8A7E7A2Y16	22
A8A7E7A1C146	17	A8A7E7A2C139	21	A8A7E7A2Y17	22
A8A7E7A1C146	14	A8A7E7A2C141	21	A8A7E7A2Y18	22
A8A7E7A1C146	14	A8A7E7A2C143	21	A8A7E7A2Y19	22
A8A7E7A1C146	19	A8A7E7A2C145	21	A8A7E7A2Y2	22
A8A7E7A1C146	20	A8A7E7A2C147	21	A8A7E7A2Y20	22
A8A7E7A1C148	17	A8A7E7A2C149	21	A8A7E7A2Y3	22
A8A7E7A1C148	14	A8A7E7A2C151	21	A8A7E7A2Y4	22

**SECTION V INDEX-REFERENCE DESIGNATION
CROSS-REFERENCE TO PAGE NUMBER (Continued)**

REFERENCE DESIGNATION	PAGE NUMBER	REFERENCE DESIGNATION	PAGE NUMBER	REFERENCE DESIGNATION	PAGE NUMBER
A8A7E7A2YC	22	A8A7KP13I15	44	A8A7MP8H22	26
A8A7E7A2Y6	22	A8A7MP13I16	44	A8A7MP8H3	25
A8A7E7A2Y7	22	A8A7MP14	44	A8A7MP8H4	25
A8A7E7A2Y8	22	A8A7MP14BL	44	A8A7MP8H5	25
A8A7E7A2Y9	22	A8A7MP14H2	44	A8A7MP8H6	25
A8A7E8	45	A8A7MP14B3	44	A8A7MP8H7	25
A8A7E9	45	A8A7HP14B4	44	A8A7MP8H8	25
A8A7HL	44	A8A7MP14B5	44	A8A7MP8H9	25
A8A7H2	44	A8A7KP14B6	44	A8A7MP9	42
A8A7L34	15	A8A7MP15	45	A8A7MP9H1	42
A8A7L35	15	A8A7MP16	45	A8A7MP9HL0	43
A8A7L36	15	A8A7MP17	45	A8A7MP9HL1	43
A8A7L37	15	A8A7MP18	45	A8A7MP9HL2	43
A8A7MP1	15	A8A7MP2	15	A8A7MP9HL3	43
A8A7MP10	43	A8A7KP3	15	A8A7MP9HL4	43
A8A7XP10BL	43	A8A7MP4	15	A8A7MP9H2	42
A8A7MP10B2	43	A8A7MP5	15	A8A7MP9B3	42
A8A7MP10B3	43	A8A7MP6	15	A8A7MP9H4	42
A8A7MP10B4	43	A8A7MP7	25	A8A7MP9H5	42
A8A7MP10H5	43	A8A7MP7BL	25	A8A7MP9H6	42
A8A7MP10B6	43	A8A7MP7B2	25	A8A7MP9H7	43
A8A7MP11	43	A8A7MP783	25	A8A7MP9H8	43
A8A7XP11	43	A8A7MP7B4	25	A8A7MP9H9	43
A8A7MP11B2	43	A8A7MP8	25	A8A7P1	16
A8A7MP11B3	43	A8A7KP8BL	25	A8A7PIA1	16
A8A7KP11K4	43	A8A7MP8BL0	25	A8A7P1A2	16
A8A7MP11B5	43	A8A7MP82111	25	A8A7PIH1	16
A8A7KP11H6	43	A8A7MP8HL2	25	A8A7P1H2	16
A8A7XP12	43	A8A7MP8BL3	25	A8A7P1H3	16
A8A7XP12B1	43	A8A7MP8H14	25	A8A7P1H4	16
A8A7MP12H2	43	A8A7MP8BL5	26	A8A7P2	15
A8A7MP12H3	44	A8A7MP8BL6	26	A8A7P2AL	16
A8A7MP12H4	44	A8A7MP8B17	26	A8A7P2A2	16
A8A7MP13	44	A8A7MP8B18	26	A8A7P2A3	16
A8A7MP13H1	44	A8A7KP8HL9	26	A8A7P2H1	15
A8A7MP13H2	44	A8A7MP8H2	25	A8A7P2H2	15
A8A7MP1383	44	A8A7KP8B20	26	A8A7P2H3	15
A8A7MP13H4	44	A8A7MP8B21	26	A8A7P2H4	16

**SECTION V INDEX-REFERENCE DESIGNATION
CROSS-REFERENCE TO PAGE NUMBER (Continued)**

REFERENCE DESIGNATION	PAGE NUMBER	REFERENCE DESIGNATION	PAGE NUMBER	REFERENCE DESIGNATION	PAGE NUMBER
A8A7TB1	33	A8A7TB1E11H2	38	A8A7TB1E7H1	37
A8A7TB1CR10	36	A8A7TB1E12	38	A8A7TB1E7H2	37
A8A7TB1CR11	36	A8A7TB1E12H1	38	A8A7TB1E8	37
A8A7TB1CR12	36	A8A7TB1E12H2	38	A8A7TB1E8H1	37
A8A7TB1CR13	36	A8A7TB1E13	38	A8A7TB1E8H2	37
A8A7TB1CR14	36	A8A7TB1E13H2	38	A8A7TB1E9	37
A8A7TB1CR15	36	A8A7TB1E14	38	A8A7TB1E9R1	37
A8A7TB1CR9	36	A8A7TB1E14H1	38	A8A7TB1E9H2	37
A8A7TB1C160	33	A8A7TB1E14H2	38	A8A7TB1H1	34
A8A7TB1C161	33	A8A7TB1E15	38	A8A7TB1H2	34
A8A7TB1C162	33	A8A7TB1E15B1	38	A8A7TB1H3	34
A8A7TB1C163	33	A8A7TB1E15E2	38	A8A7TB1H4	34
A8A7TB1C164	33	A8A7TB1E16	38	A8A7TB1H5	34
A8A7TB1C165	33	A8A7TB1E16E1	38	A8A7TB1H6	34
A8A7TB1C166	33	A8A7TB1E16E2	38	A8A7TB1128	34
A8A7TB1C167	34	A8A7TB1E17	38	A8A7TB1129	34
A8A7TB1C168	34	A8A7TB1E17H1	38	A8A7TB1130	34
A8A7TB1C169	34	A8A7TB1E17H2	38	A8A7TB1131	34
A8A7TB1C170	34	A8A7TB1E18	38	A8A7TB1132	34
A8A7TB1C171	34	A8A7TB1E18H1	38	A8A7TB1Q24	39
A8A7TB1C172	34	A8A7TB1E18R2	38	A8A7TB1Q25	39
A8A7TB1C173	34	A8A7TB1E2	36	A8A7TB1Q26	39
A8A7TB1C174	34	A8A7TB1E2B1	36	A8A7TB1Q27	39
A8A7TB1C175	34	A8A7TB1E2E2	36	A8A7TB1Q28	39
A8A7TB1C176	34	A8A7TB1E3	37	A8A7TB1Q29	39
A8A7TB1C177	33	A8A7TB1E3H1	37	A8A7TB1R119	35
A8A7TB1C178	34	A8A7TB1E3B2	37	A8A7TB1R120	35
A8A7TB1C179	34	A8A7TB1E4	37	A8A7TB1R121	36
A8A7TB1C180	34	A8A7TB1E4E1	37	A8A7TB1R122	36
A8A7TB1E1	33	A8A7TB1E4E2	37	A8A7TB1R123	35
A8A7TB1E1J2	33	A8A7TB1E5	37	A8A7TB1R124	35
A8A7TB1E1J3	33	A8A7TB1E5E1	37	A8A7TB1R125	36
A8A7TB1E1J4	33	A8A7TB1E5E2	37	A8A7TB1R126	36
A8A7TB1E10	37	A8A7TB1E6	37	A8A7TB1R127	36
A8A7TB1E10E1	37	A8A7TB1E6E1	37	A8A7TB1R128	36
A8A7TB1E10E2	37	A8A7TB1E6E2	37	A8A7TB1R129	36
A8A7TB1E11	37	A8A7TB1E7	37	A8A7TB1R130	35
A8A7TB1E11H1	38			A8A7TB1R131	35

**SECTION V INDEX-REFERENCE DESIGNATION
CROSS-REFERENCE TO PAGE NUMBER (Continued)**

REFERENCE DESIGNATION	PAGE NUMBER	REFERENCE DESIGNATION	PAGE NUMBER	REFERENCE DESIGNATION	PAGE NUMBER
A8A7TR1R132	36	A8A7TB1T3	39	A8A8M5H7	194
A8A7TB1R133	36	A8A7TB1T3H1	39	A8A8MP5H8	144
A8A7TB1R134	35	A8A7TB1T3H2	39	A8A8MP5H9	194
A8A7TB1R135	35	A8A7TB1T3H3	39	A8A9	194
A8A7TB13136	36	A8A7TB1T3H4	39	A8A9MP1	191
A8A7TR1R137	36	A8A7TB1T3H5	39	A8MP1	193
A8A7TB1R139	35	A8A7TB1T3H6	39	A8MP1H1	193
A8A7TB1R 14 0	36	A8A7TB1T3H7	39	A8MP1H2	193
A8A7TB1R141	35	A8A7TB1T3H8	39	A8MP1H3	193
A847TB1R142	35	A8A7TB1T4	39	A8MP1H4	193
A8A7TB1R143	35	A8A7W1	33	A8MP1H5	193
A8A7TB1R143	34	A8A8	193	A8MP2	193
A8A7TB1R144	35	A8A8H2	193	A8MP3	193
A8A7TB1R141	35	A8A8H2	193	A8MP4	194
A8A7TB1R144	35	A8A8H2	193	A8MP5	194
A8A7TB1R141	35	A8A8H4	193	A8MP5H1	194
A8A7TR1R144	35	A8A8H4	193	A8MP5R2	194
A8A7TB1R141	35	A8A8H4	193	A8MP5H3	194
A8A7TE1R1kh	35	A8A8MP1	193	A8MP5114	195
A6A7TB1R144	35	A8A8MP2	193	A8MP6	195
A6A7TB1R144	35	A8A8MP2H1	193	A8MP6H1	195
A6A7TB1R145	35	A8A8MP2H2	193	A8MP612	195
A6A7TB1R146	35	A8A8MP3	193	A8h1P6H3	195
A8A7TB1R147	35	A8A8MP4	194	A8MP6H4	195
A8A7TB1R148	36	A8A8MP5	194	A8MP7	195
A8A7TB1R149	36	A8A8MP5H1	194	A8MP8	195
A8A7TB1R150	36	A8A8MP5H10	194	A8MP8H1	195
A8A7TB1R151	35	A3A8MP5H11	194	A8MP8H2	195
A8A7TB1T152	38	A3A8MP5H12	194	A8MP8H3	95
A8A7TB1T1H1	38	A8A8MP5H13	194	A8MP8H4	195
A8A7TB1T1H2	39	A8A8MP5H14	194	CP1	6
A8A7TB1T1H3	39	A6A8MP5H15	194	HT1	10
A8A7TB1T1H4	39	A8A8MP5H16	194	MP4	13
A8A7TB1T1H5	39	A8A8MP5H2	191	MP5	195
A8A7TB1T1H6	39	A8A8MP5H3	194	W1	196
A8A7TB1T1H7	39	A8A8MP5H4	194	W2	196
A8A7TB1T1H8	39	A8A8MP5H5	194	W3	196
A6A7TB1T2	39	A8A8MP5H6	194	W4	196

INDEX

	Paragraph	Page
Adjustments, depot maintenance.....	5-3	5-1
Transmit mixer balance and tgc adjustments.....	5-4	5-1
Alignment and Adjustments, direct support.....	3-20	3-116
Adjustments		
Balanced modulator	3-29	3-130
Microphone amplifier gain.....	3-25	3-127
Power amplifier grid drive and bias	3-27	3-128
Receiver agc circuit	3-23	3-125
Receiver audio output	3-22	3-125
Temperature compensated oscillator, frequency	3-28	3-129
Transmitter sidetone.....	3-24	3-126
Transmitter vox again.....	3-26	3-127
Mechanical alignment, slug rack coupler, CV-1377A/PRC47	3-21	3-124
Test equipment and special tools required (chart)	3-20	3-116
Amplifier-Modulator AM-3507/PRC-47 (A8A2)		
Dc resistance, coils and transformer windings (chart)	3-7	388
Historical revisions	1-4	1-1
Module assembly and disassembly	3-13	3-98
Theory of operation	2-10	2-18
Application, system	2-1	2-1
Assembly and disassembly	3-10	3-97
Frequency selection mechanism	3-16	3-107
Front panel removal and reassembly, main chassis	3-19	3-114
Power amplifier load and tune mechanism.....	3-15	3-104
Power amplifier (A8A4A1)1 plate capacitor switch	3-17	3-111
Power amplifier (A8A4A1) XMTR PWR switch	3-18	3-112
Removal and replacement, case, receiver-transmitter	3-11	3-97
Removal and replacement, plug-in modules.....	3-12	3-97
Module assembly and disassembly	3-13	3-98
Amplifier-Modulator AM-3507/PRC-47 (A8A2).....	3-13 <i>b</i>	3-99
Audio Frequency Amplifier AM-3506/PRC-47 (A8A1)	3-13 <i>a</i>	3-98
Oscillator Control C-4311/PRC-47 (ASA7)	3-13 <i>f</i>	3-102
Power Supply PP-3518/PRC-47 (A8A51)	3-13 <i>d</i>	3-100
Radio Frequency Oscillator 0-1032/PRC-47 (A8A6)	3-13 <i>e</i>	3-101
Signal Data Translator CV-1377A/PRC-47 (A8A3)	3-13 <i>c</i>	3-99
Audio Frequency Amplifier AM-3506/PRC-47 (A8A1)		
Dc resistance, coils and transformer windings (chart)	3-7	3-88
Historical revisions	1-4	1-1
Module assembly and disassembly	3-13	3-98
Theory of operation	2-9	2-14
Block diagram explanations.....	2-2	2-1
Block diagram, overall	2-3	2-1
Balanced modulator adjustments.....	3-29	3-130
Cable Assembly Set AN/PRA-4.....	32	3-2
Contents and use (chart)	3-2	3-2
Coils and transformer windings, dc resistance of	3-7	3-88
Cw operation test, transmitter	4-18	4-17
DA Pam 310-4	1-2	1-1
DA Pam 310-7	1-2	1-1
Dc resistance of coils and transformer windings	3-7	3-88
Amplifier-Modulator AM-3507/PRC-47 (A8A2) (chart).....	3-7 <i>a</i> (2)	3-88
Audio Frequency Amplifier AM-3506/PRC-47 (A8A1) (chart).....	3-7 <i>a</i> (1)	3-88
Electrical Equipment Chassis CH-474/PRC-47 (A8A4) (chart)	3-7 <i>a</i> (7)	3-89
Oscillator Control C-4311/PRC-47 (A8A7) (chart)	3-7 <i>a</i> (6)	3-88
Power amplifier compartment (chart).....	3-7 <i>a</i> (8)	3-89
Power amplifier filter box FL2 (chart).....	3-7 <i>a</i> (9)	3-89
Power Supply PP-3518/PRC-47 (A8A51) chart)	3-7 <i>a</i> (4)	3-88
Radio Frequency Oscillator 0-1032/PRC-47 (A8A6) (chart)	3-7 <i>a</i> (5)	3-88
Signal Data Translator CV-1377A/PRC-47 (A8A3) (chart).....	3-7 <i>a</i> (3)	3-88
Depot maintenance.....	5-1	5-1
Equipment adjustments.....	5-3	5-1

	Paragraph	Page
Transmitter hum balance adjustment.....	5-5	5-2
Transmit mixer balance and tgc adjustment.....	5-4	5-1
Transmitter modulation fidelity test.....	5-6	5-3
Transmitter spurious output adjustments	5-7	5-4
Description, general theory	2-4	2-3
Frequency control circuits	2-7	2-9
Power supply circuits	2-8	2-12
Receive signal path	2-5	2-8
Transmit signal path	2-6	2-9
DT support maintenance.....	3-1	3-1
General troubleshooting techniques.....	3-1	3-1
Tools, test equipment, and materials.....	3-2	3-2
Cable Assembly Set AN/PRA-4 (chart)	3-2	3-2
Direct support troubleshooting	3-3	3-3
Overall troubleshooting	3-3	3-3
Radio Receiver-Transmitter RT-671/PRC-47 (AH)	3-4	3-3
Localizing trouble	3-5	3-75
Frequency generation circuits (chart)	3-5c	3-81
Power distribution circuits (chart, common parts).....	3-5b (3)	3-77
Power distribution circuits (chart, 26.5 vdc)	3-5b (2)	3-76
Power distribution circuits (chart, 115 vac)	3-5b (1)	3-75
Receiver circuit tests (chart)	3-5d	3-82
Relay and mode control tests (chart)	3-5f	3-85
Transmitter circuit tests (chart)	3-5e	3-83
Receiver test setup and initial settings	3-4b (2)	3-73
Sectionalizing trouble (chart).....	3-4	3-3
Short circuit tests (chart)	3-4	3-3
Transmitter test setup and initial settings	3-4	3-3
Distortion test, receiver audio output, general support	4-12	4-7
Electrical Equipment Chassis CH-474/PRC-47		
Dc resistance, coils and transformer windings (chart)	3-7	38
Field modifications (vox option)	2-1	2-1
Historical revisions	1-4	1-1
Theory of operation	2-15	2-31
Equipment publication improvements, reporting of.....	1-3	1-1
Field modification, vox mode operation	2-1	2-1
Filter box, power amplifier (FL2), resistance of coils	3-7	3-8
Frequency generation circuit tests, troubleshooting	3-5	3-75
Frequency selection mechanism, assembly and disassembly	3-16	3-107
Frequency stability test, transmitter, general support	4-16	4-14
Front panel removal and reassembly, main chassis and	3-19	3-114
General description, theory	2-4	2-3
Frequency control circuits	2-7	2-9
Power supply circuit	2-8	2-12
Receive signal path	2-5	2-8
Transmit signal path	2-6	2-9
General removal and replacement procedures, repair	3-8	3-95
Removal and replacement, case, receiver-transmitter	3-11	3-97
Removal and replacement, plug-in modules.....	3-12	3-97
Removal and replacement, power amplifier (A8A4A1) tube.....	3-14	3-95
Removal and replacement, subminiature tube.....	3-8	3-95
General replacement techniques, repair	3-8	3-95
General support maintenance	4-1	4-1
Modification work orders.....	4-4	4-1
Physical tests and inspection (chart)	4-5	4-1
Receiver audio output distortion test	4-12	4-7
Receiver avc characteristic tests	4-7	4-4
Receiver if. rejection test	4-9	4-6
Receiver image rejection test	4-1	4-6
Receiver power input requirements	4-13	4-8
Receiver selectivity tests	4-8	4-5
Receiver sensitivity tests	4-6	4-2
Receiver volume control test.....	4-11	4-7
Test equipment required (chart)	4-2	4-1
Test facilities	4-3	4-1
Transmitter cw operation test	4-18	4-17

	Paragraph	Page
Transmitter frequency stability test	4-16	4-14
Transmitter output mw sensitivity test	4-15	4-13
Transmitter power input test.....	4-1	4-45
Transmitter power output test	4-14	4-9
Transmitter sidetone test	4-19	4-18
Historical revisions to equipment	1-4	1-1
Amplifier-Modulator AM-3507/PRC.47 (ASA2)	1-4 <i>b</i>	1-1
Audio Frequency Amplifier AM.3506/PRC47 (ASAI).....	1-4 <i>b</i>	1-1
Electrical Equipment Chassis CH-474/PRC-47 (A884)	1-4 <i>b</i>	1-1
Oscillator Control C-4311/PRC47 (ASA7)	1-4 <i>b</i>	1-1
Power Supply PP-3518/PRC-47 (A8A5)	1-4 <i>b</i>	1-1
Radio Frequency Oscillator O-1032/PRC47 (ASA6)	1-4 <i>b</i>	1-1
Signal Data Translator CV-1377A/PRC-47 (ASA3)	1-4 <i>b</i>	1-1
If. rejection test, receiver, general support.	4-9	4-6
Image rejection test, receiver, general support.....	4-10	4-6
Improvements, equipment publication, reporting of	1-3	1-1
Index of publications	1-2	1-1
Inspection, physical tests and (chart)	4-5	4-1
Localizing trouble, receiver-transmitter	3-5	3-75
Frequency generation circuits (chart)	3-5 <i>c</i>	3-81
Power distribution circuits (chart, common parts)	3-5 <i>b</i> (3)	3-77
Power distribution circuit (chart, 26.5 vdc)	3-5 <i>b</i> (2)	3-76
Power distribution circuits (chart, 115 vac)	3-5 <i>b</i> (1)	3-75
Receiver circuit tests (chart)	3-5 <i>d</i>	3-82
Relay and mode control tests (chart)	3-5 <i>f</i>	3-85
Transmitter circuit tests (chart).....	3-5 <i>e</i>	3-83
Lubrication procedure, power amplifier load-tune mechanism	3-15	3-104
Microphone amplifier gain adjustment	3-26	3-127
Module, trouble isolation	3-6	3-87
Dc resistance measurements (chart)	3-7	3-88
Official nomenclature (chart)	2-2	2-1
Omissions, and recommendations, report of errors and	1-3	1-1
Oscillator Control C-4311/PRC-47		
Dc resistance, coils and transformer windings (chart)	3-7 <i>a</i> (6)	3-88
Historical revisions	1-4	1-1
Module assembly and disassembly	3-13	3-98
Theory of operation	2-14	2-29
Output meter sensitivity test, transmitter, general support	4-15	4-13
Panel Cover CW647/PRC-47	2-2	2-1
Physical tests and inspection, general support	4-5	4-1
(chart)	4-5	4-1
Power amplifier compartment		
Dc resistance, coils and transformer windings (chart)	3-7	3-88
Grid drive and bias adjustments	3-27	3-128
Power amplifier filter box (FL2I)		
Dc resistance, coils and transformer windings (chart)	3-7	3-88
Power amplifier load and tune mechanism		
Assembly and disassembly	3-15	3-104
Lubrication process	3-15	3-104
Power amplifier plate capacitor switch		
Assembly and disassembly	3-17	3-111
Power amplifier tube removal and replacement.....	3-14	3-103
Power amplifier XMTR PWR switch		
Assembly and disassembly	3-18	3-112
Power distribution circuits, troubleshooting		
Common parts (chart)	3-5	3-75
26.5-volt dc circuits (chart)	3-5	3-75
115-volt ac circuits (chart)	3-5	3-75
Power input requirements, receive mode	4-13	4-8
Power input test, transmitter	4-17	4-15
Power output test, transmitter	4-14	4-9
Power supply circuits, theory of operation	2-8	2-12
Power Supply PP-3518/PRC47 (A5)		
Dc resistance, coils and transformer windings (chart)	3-7	3-88
Historical revisions	1-4	1-1
Module assembly and disassembly	3-13	3-98
Theory of operation	2-12	2-27

	Paragraph	Page
Radio Frequency Oscillator 0-1032/PRC47 (A6)		
Dc resistance, coils and transformer windings (chart)	3-7	3-88
Historical revisions	1-4	1-1
Module assembly and disassembly.....	3-13	3-98
Temperature compensated oscillator, frequency adjustment.....	3-28	3-129
Theory of operation	2-13	2-28
Radio Receiver-Transmitter RT-671/PRC-47		
Alignment and adjustments.....	3-20	3-116
Balanced modulator adjustments	3-2 9	3-130
Microphone amplifier gain adjustment	3-25	3-127
Mechanical alignment, CV-1377A/PRC-47, slug rack coupler	3-21	3-124
Power amplifier grid drive and bias adjustment.....	3-27	3-128
Receiver agc circuit adjustments	3-2	3-125
Receiver audio output adjustments.....	3-22	3-125
Temperature compensated oscillator, frequency adjustment.....	3-28	3-129
Transmitter vox gain adjustment	3-26	3-127
Depot maintenance	5-1	5-1
Equipment adjustments.....	5-3	5-1
Transmitter hum balance adjustment.....	5-5	5-2
Transmit mixer balance and tgc adjustment.....	5-4	5-1
Transmitter modulation fidelity test	5-6	5-3
Transmitter spurious output adjustments.....	5-7	5-4
General support maintenance.....	4-1	4-1
Physical tests and inspection (chart)	4-5	4-1
Receiver audio output distortion test	4-12	4-7
Receiver avc characteristic tests	4-7	4-4
Receiver if. rejection tests	4-9	4-4
Receiver image rejection test	4-10	4-6
Receiver power input requirements	4-13	4-8
Receiver selectivity test	4-8	4-5
Receiver sensitivity tests	4-6	4-2
Receiver volume control test.....	4-11	4-7
Transmitter cw operation test	4-18	4-17
Transmitter frequency stability test	4-16	4-14
Transmitter output meter sensitivity test	4-15	4-13
Transmitter power input test	4-17	4-15
Transmitter power output test.....	4-14	4-9
Transmitter sidetone test	4-19	4-18
Module assembly and disassembly	3-13	3-98
Removal and replacement, case	3-11	3-97
Troubleshooting, direct support.....	3-4	3-3
Localizing trouble.....	3-5	3-75
Frequency generation circuits test (chart)	3-5c	3-81
Power distribution circuits (chart, common parts).....	3-5b (3)	3-77
Power distribution circuits (chart, 26.5 vdc)	3-5b (2)	3-76
Power distribution circuits (chart, 115 vac)	3-5b (1)	3-75
Receiver circuit tests (chart)	3-5d	3-82
Relay and mode control tests (chart).....	3-5f	3-85
Transmitter circuit test (chart)	3-5e	3-83
Receiver test setup and initial settings	3-4b (2)	3-73
Sectionalizing trouble (chart)	3-4	3-3
Short circuit test (chart)	3-4	3-3
Transmitter test setup and initial settings.....	3-4	3-3
Receive signal path, theory	2-5	2-8
General removal and replacement procedures.....	3-8	3-95
Printed circuit card repair.....	3-8	3-96
General replacement techniques.....	3-8	3-95
Power amplifier tube removal and replacement.....	3-14	3-103
Subminiature tube replacement.....	3-8	3-95
Module assembly and disassembly.....	3-13	3-98
Amplifier-Modulator AM-350/PRC-47 (A8A2).....	3-13b	3-99
Audio Frequency Amplifier AM-3506/PRC-47 (A8A1).....	3-13a	3-98
Oscillator Control C-4311/PRC-47(A8A7)	3-13f	3-102
Radio Frequency Oscillator 0-1032/PRC-47 (A8A6)	3-13d	3-100
Power Supply PP-3518/PRC47 (A8A5)	3-13	3-101
Signal Data Translator CV-1377A/PRC-47 (A8A3).....	3-13	3-99

	Paragraph	Page
Subassembly removal and replacement		
Frequency selection mechanism.....	3-16	3-107
Front panel removal and reassembly, main chassis	3-19	3-114
Power amplifier load and tune mechanism.....	3-15	3-104
Power amplifier plate capacitor switch	3-17	3-111
Power amplifier XMTR PWR switch.....	3-18	3-112
Receiver-transmitter case	3-11	3-97
Reporting of equipment publication improvements.....	1-3	1-1
Removal and replacement procures	3-8	3-95
Case, receiver-transmitter	3-11	3-97
Frequency selection mechanism	3-16	3-107
Main chassis and front panel removal and reassembly	3-19	3-114
Plug-in modules	3-12	3-97
Power amplifier load and tune mechanism.....	3-15	3-104
Power amplifier plate capacitor switch	3-17	3-111
Power amplifier (A8A4A1) tube removal and replacement.....	3-14	3-103
Power amplifier XMTR PWR switch	3-18	3-112
Resistance of coils and transformer windings		
Amplifier-Modulator AM3507/PRC-47 (A8A2).....	3-7a (2)	3-88
Audio Frequency Amplifier AM3506/PRC-47 (A8A1).....	3-7a (1)	3-88
Electrical Equipment Chassis CH-474/PRC-47	3-7a (7)	3-89
Oscillator Control C-4311/PRC-47 (A8A7)	3-7a (6)	3-88
Power amplifier compartment	3-7a (8)	3-89
Power amplifier filter box (FL2)	3-7a (9)	3-89
Power Supply PP-3518/PRC-47 (A8A5)	3-7a (4)	3-88
Radio Frequency Oscillator O-1032/PRC-47 (A8A6).....	3-7a (5)	3-88
Signal Data Translator CV-1377A/PRC47 (A8A3).....	3-7a (3)	3-88
Revisions to equipment, historical	1-4	1-1
Amplifier-Modulator AM-3507/PRC-47 (A8SA2).....	1-4b	1-1
Audio Frequency Amplifier AM-3506/PRC-47 (A8A1).....	1-4b	1-1
Electrical Equipment Chassis CH-474/PRC-47	1-4b	1-1
Oscillator Control C-4311/PRC-47 (A8A7)	1-4b	1-1
Power Supply PP-3518/PRC-47 (A8AS)	1-4b	1-1
Radio Frequency Oscillator O-1032/PRC47 (A8A6)	1-4b	1-1
Signal Data Translator CV-1377A/PRC-47 (A8A3)	1-4b	1-1
Scope	1-1	1-1
Sectionalizing trouble, receiver-transmitter (chart)	3-4	3-3
Selectivity tests, receiver, general support	4-8	4-5
Sensitivity tests, receiver, general support	4-6	4-2
Short circuit teats, receiver-transmitter (chart)	3-4	3-3
Sidetone adjustment, transmitter.....	3-24	3-126
Sidetone test, transmitter, general support	4-19	4-18
Signal Data Translator CV-1377A/PRC-47 (A8A3)		
Dc resistance, coils and transformer windings (chart)	3-7	3-88
Historical revisions	1-4	1-1
Mechanical alignment, slug rack coupler	3-21	3-124
Module assembly and disassembly	3-13	3-98
Theory of operation	2-11	2-21
Standards, depot overhaul	6-1	6-1
Subminiature tube replacement	3-8	3-95
System application.....	2-1	2-1
System block diagram, explanation	2-3	2-1
System function	2-1	2-1
Temperature compensated oscillator, frequency adjustment	3-28	3-129
Test equipment (chart), direct support	3-2	3-2
Test equipment (chart). general support.....	4-2	4-1
Test facilities, general support	4-3	4-1
Theory, general description.....	2-4	2-3
Frequency control circuits	2-7	2-9
Power supply circuits	2-8	2-12
Receive signal path.....	2-5	2-8
Transmit signal path.....	2-6	2-9
Theory of operation.....	2-9	2-14
Amplifier-Modulator AM-3507/PRC-47 (A8A2).....	2-10	2-18
Frequency Amplifier AM-3506/PRC-47 (A8A)I	2-9	2-14
Electrical Equipment Chassis CH-474/PRC-47 IA8A4	2-15	2-31

	Paragraph	Page
Oscillator Control C-4311/PRC-47 (A8A7)	2-14	2-29
Power Supply PP-3518/PRC-47 (A8A5)	2-12	2-27
Radio Frequency Oscillator O-1032/PRC-47 (A8A6)	2-13	2-28
Signal Data Translator CV-1377A/PRC-47 (A8A3)	2-11	2-21
Tools, test equipment and material, direct support	3-2	3-2
Transformer windings, dc resistance of coils and	3-7	3-88
Transmitter hum balance adjustment	5-5	6-2
Transmit mixer balance and tgc adjustments	5-4	5-1
Transmitter modulation fidelity test	5-6	5-3
Transmit signal path, theory.....	2-6	2-9
Transmitter spurious output adjustment	6-7	6-4
Trouble, isolating	3-6	3-87
Isolation within a module	3-9	3-87
Troubleshooting techniques, direct support	3-1	3-1
Troubleshooting, direct support	3-3	3-3
Radio Receiver-Transmitter RT-671/PRC-47	3-4	3-3
Localizing trouble	3-5	3-75
Frequency generation circuits (chart)	3-6c	3-81
Power distribution circuits (chart, common parts)	3-5b (3)	3-77
Power distribution circuits (chart, 26.5 vdc)	3-5b (2)	3-7
Power distribution circuits (chart 115 vac)	3-5b (1)	3-75
Receiver circuit tests (c hart)	3-5d	3-82
Relay and mode control tests (chart)	3-5f	3-85
Transmitter circuit tests (chart)	3-5e	3-83
Receiver test setup and initial settings	3-4b (2)	3-73
Sectionalizing trouble (chart).....	3-4	3-3
Short circuit tests (chart)	3-4	3-3
Transmitter test setup and initial settings	3-4	3-3
Volume control test, receiver, general support	4-11	4-7
Vox gain adjustment, transmitter	3-26	3-127
Vox operation, field modification	2-1	2-1

By Order of the Secretary of the Army:

Official:

VERNE L. BOWERS

*Major General, United States Army,
The Adjutant General.*

FRED C. WEYAND

*General, United States Army,
Vice Chief of Staff.*

DISTRIBUTION:

To be distributed in accordance with DA Form 12-51 (qty rqr block No. 339) direct and general support maintenance requirements for AN/PRC-47.

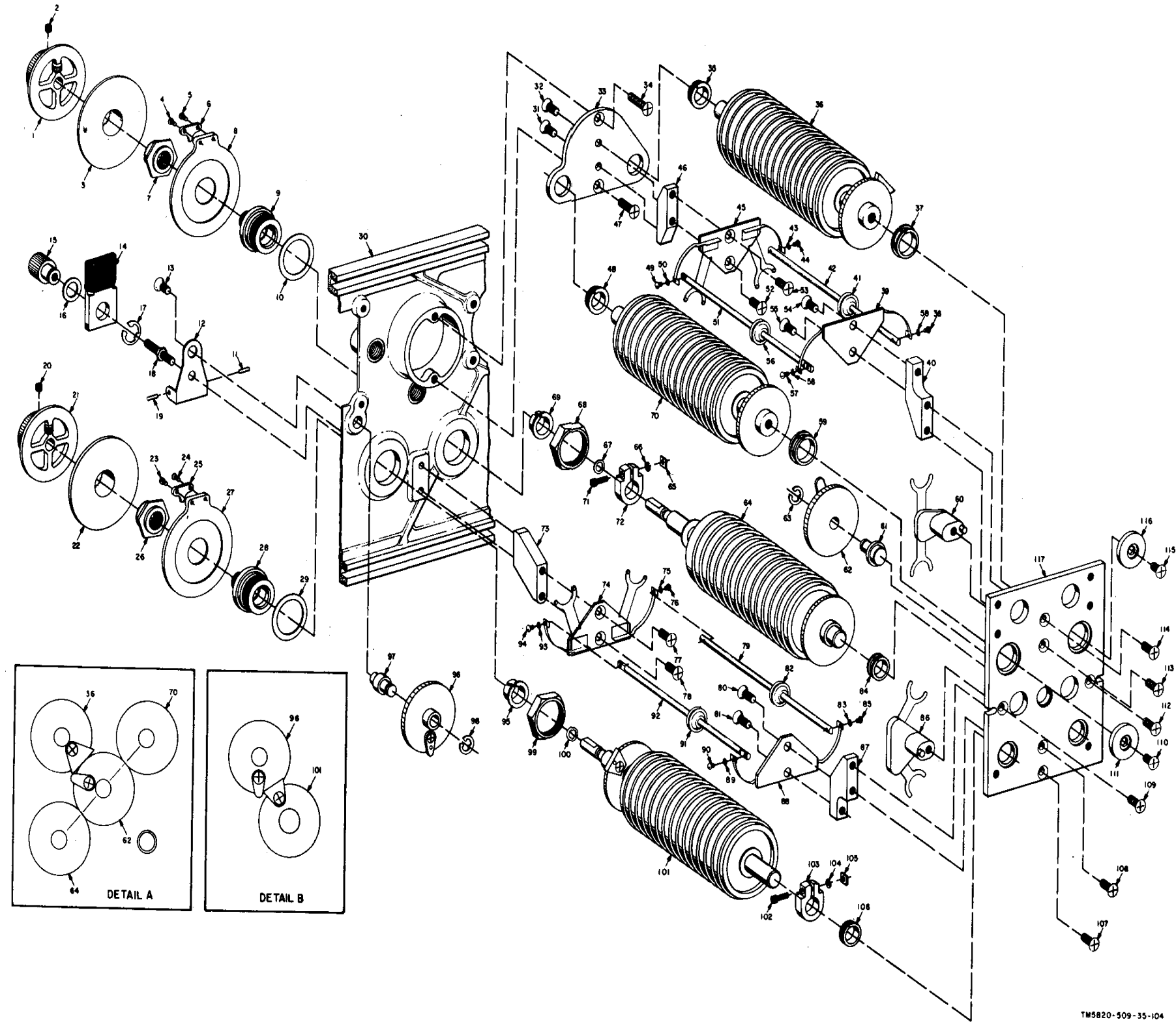

LEGEND FOR FIGURE 3-89

- 1 Knob, vernier drive
- 2 Setscrew, 10-32 x 1/4
- 3 Scale, vernier, primary
- 4 Screw, round head, 1-72 x 1/8
- 5 Screw, round head, 1-72 x 1/8
- 6 Pointer, vernier scale
- 7 Collar, vernier drive shaft
- 8 Scale, vernier, secondary
- 9 Bushing, panel
- 10 Gasket, 13/16 ID x 1-1/32 OD x 0.010 in. thk.
- 11 Pin, grooved, 0.0625 OD x 1/4
- 12 Plate, support, dial lock
- 13 Screw, flat head, 6-32 x 7/16
- 14 Stop, dial
- 15 Knob, LOCK
- 16 Washer, flat, 0.265 ID
- 17 E-ring, 0.180 ID
- 18 Stud, shouldered
- 19 Pin, grooved, 0.0625 OD x 1/4
- 20 Setscrew, 10-32 x 1/4
- 21 Knob, vernier drive
- 22 Scale, vernier, primary
- 23 Screw, round head, 1-72 x 1/8
- 24 Screw, round head, 1-72 x 1/8
- 25 Pointer, vernier scale
- 26 Collar, vernier drive shaft
- 27 Scale, vernier, secondary
- 28 Bushing, panel
- 29 Gasket, 13/16 ID x 1-1/32 OD x 0.010 in. thk.
- 30 Panel, RT-671/PRC-47
- 31 Screw, flat head, 6-32 x 5/16
- 32 Screw, flat head, 6-32 x 5/16
- 33 Meter shield
- 34 Screw, flat head, 4-40 x 1/4
- 35 Bearing, sleeve, nylon
- 36 Inductor, RF no. 1 (L111)
- 37 Bearing, sleeve, nylon
- 38 Screw, round head, 0-80 x 1/8
- 39 Spring Assy, roller, upper
- 40 Mounting block, upper, nylon
- 41 Electrical Contact, roller
- 42 Rod, roller contact
- 43 Washer, lock #0
- 44 Screw, round head, 0-80 x 1/8
- 45 Contact Spring Assy, upper, front
- 46 Mounting block, upper, nylon
- 47 Screw, flat head, 4-40 x 1/4
- 48 Bearing, sleeve, nylon
- 49 Screw, round head, 0-80 x 1/8
- 50 Washer, lock #0
- 51 Rod, roller contact
- 52 Screw, flat head, 6-32 x 1/4
- 53 Screw, flat head, 6-32 x 1/4
- 54 Screw, flat head, 6-32 x 1/4
- 55 Screw, flat head, 6-32 x 1/4
- 56 Electrical Contact, roller
- 57 Screw, round head, 0-80 x 1/8
- 58 Washer, lock #0
- 59 Bearing, sleeve, nylon
- 60 Contact Assy, rear, left side
- 61 Stub shaft, idler
- 62 Gear and Stop Assy, idler
- 63 E-ring, 0.180 ID
- 64 Inductor, RF no. 3 (L112)
- 65 Nut, square, 4-40
- 66 Washer, lock, #4
- 67 Washer, flat
- 68 Nut, hex, 1/4-16
- 69 Bearing, sleeve, nylon
- 70 Inductor, RF no. 2 (L110)
- 71 Screw, collar, 4-40
- 72 Collar, shaft
- 73 Mounting block, lower, nylon
- 74 Contact Spring Assy, lower, front
- 75 Washer, lock, #0
- 76 Screw, round head, 0-80 x 1/8
- 77 Screw, flat head, 6-32 x 1/4
- 78 Screw, flat head, 6-32 x 1/4
- 79 Rod, electrical contact
- 80 Screw, flat head, 6-32 x 1/4
- 81 Screw, flat head, 6-32 x 1/4
- 82 Electrical Contact, roller
- 83 Washer, lock, #0
- 84 Bearing, sleeve, nylon
- 85 Screw, round head, 0-80 x 1/8
- 86 Contact Assy, rear, right side
- 87 Mounting block, lower, nylon
- 88 Spring Assy, roller, lower
- 89 Washer, lock, #0
- 90 Screw, round head, 0-80 x 1/8
- 91 Electrical Contact, roller
- 92 Rod, electrical contact
- 93 Washer, lock, #0
- 94 Screw, round head, 0-80 x 1/8
- 95 Bearing, sleeve, nylon
- 96 Spur Gear, idler
- 97 Stub shaft, idler
- 98 E-ring, 0.180 ID
- 99 Nut, hex, 1/4-16
- 100 Washer, flat
- 101 Inductor, RF Tuning (L109)
- 102 Screw, collar, 4-40
- 103 Collar, shaft
- 104 Washer, lock, #4
- 105 Nut, square, 4-40
- 106 Bearing, sleeve, nylon
- 107 Screw, flat head, 6-32 x 5/16
- 108 Screw, flat head, 6-32 x 5/16
- 109 Screw, flat head, 6-32 x 5/16
- 110 Screw, flat head, 6-32 x 1/4
- 111 Washer, recessed, aluminum, 0.781 OD x 0.203 ID x 0.0035 thk
- 112 Screw, flat head, 6-32 x 5/16
- 113 Screw, flat head, 6-32 x 5/16
- 114 Screw, flat head, 6-32 x 5/16
- 115 Screw, flat head, 6-32 x 1/4
- 116 Washer, recessed, aluminum, 0.781 OD x 0.203 ID x 0.0035 thk
- 117 Plate, gear, rear

Figure 3-89. Radio Receiver-Transmitter RT-671/PRC-47, Power Amplifier Compartment (A8A4AI) Load-Tune Coil Assembly, Exploded View

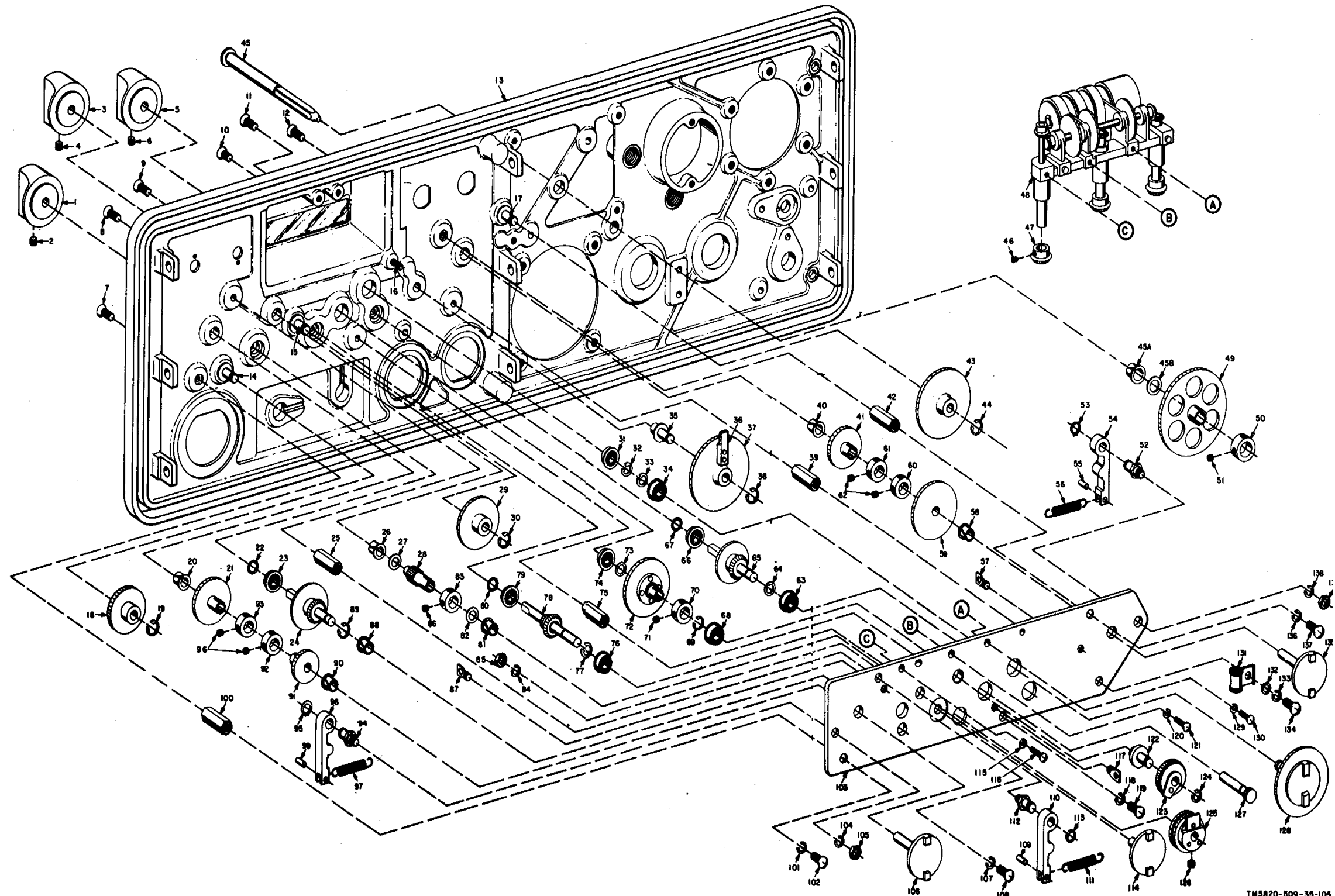

LEGEND FOR FIGURE 3-90

- | | | |
|----------------------------------|------------------------------------|----------------------------------|
| 1 Knob, 1-kHz | 46 Setscrew, 6-32 x 1/8 | 93 Collar, shaft |
| 2 Setscrew, 6-32 x 1/8 | 47 Bevel gear, 1-kHz drive | 94 Post, pivot, pawl |
| 3 Knob, 10- and 100-kHz | 48 Indicator, frequency channel | 95 Ring, snap, external, 0.168 |
| 4 Setscrew, 6-32 x 1/8 | 49 Spur gear, switch drive | 96 Setscrews, 6-32 x 1/8 |
| 5 Knob, 1-MHz | 50 Collar, shaft | 97 Spring, pawl, helical |
| 6 Setscrew, 6-32 x 1/8 | 51 Setscrew, 6-32 x 1/8 | 98 Pawl, 12 pos. no. 1 |
| 7 Screw, flat head, 6-32 x 1/4 | 52 Post, pivot, pawl | 99 Pin, spring, 0.094 x 1/4 |
| 8 Screw, flat head, 6-32 x 1/4 | 53 Ring, snap, external, 0.168 | 100 Nut, sleeve, no. 2 |
| 9 Screw, flat head, 6-32 x 1/4 | 54 Pawl, 12 pos. no. 3 | 101 Washer, lock, #6 |
| 10 Screw, flat head, 6-32 x 5/16 | 55 Pin, spring, 0.094 x 1/4 | 102 Screw, pan head, 6-32 x 3/8 |
| 11 Screw, flat head, 6-32 x 1/4 | 56 Spring, pawl, helical | 103 Plate, gear |
| 12 Screw, flat head, 6-32 x 1/4 | 57 Screw, eye, 6-32 | 104 Washer, lock, #6 |
| 13 Front panel, RT-671/PRC-47 | 58 Bearing, sleeve, nylon | 105 Nut, hex, 6-32 |
| 14 Stub shaft | 59 Detent, spur gear | 106 Coupling-half, Shaft no. 1 |
| 15 Stub shaft | 60 Collar, shaft | 107 Washer, lock, #6 |
| 16 Pin, roll, 0.125 OD x 3/8 | 61 Collar, shaft | 108 Screw, pan head, 6-32 x 3/8 |
| 17 Stub shaft | 62 Setscrew, 6-32 x 1/8 | 109 Pin, spring, 0.094 x 1/4 |
| 18 Spur gear, idler | 63 Bearing, ball, annular | 110 Pawl, 12 pos. no. 2 |
| 19 E-ring, 0.180 ID | 64 C-ring, 0.160 ID | 111 Spring, pawl, helical |
| 20 Bearing, sleeve, nylon | 65 Gear Assy, bevel-spur no. 1 | 112 Post, pivot, pawl |
| 21 Spur gear, no. 2 | 66 Bearing, ball, annular | 113 Ring, snap, external, 0.168 |
| 22 Gasket, O-ring | 67 Gasket, O-ring | 114 Coupling-half, Shaft no. 2 |
| 23 Bearing, ball, annular | 68 Bearing, ball, annular | 115 Washer, lock, #4 |
| 24 Gear Assy, bevel, no. 3 | 69 C-ring, 0.160 ID | 116 Screw, pan head, 4-40 x 5/16 |
| 25 Nut, sleeve, no. 1 | 70 Collar, shaft | 117 Screw, eye, 6-32 |
| 26 Bearing, sleeve, nylon | 71 Setscrew, 6-32 x 1/8 | 118 Washer, lock, #6 |
| 27 Washer, flat, 0.190 ID | 72 Spur gear no. 4 | 119 Screw, pan head, 6-32 x 3/8 |
| 28 Gearshaft, spur | 73 Washer, flat, shim | 120 Washer, lock, #4 |
| 29 Spur gear, idler | 74 Bearing, ball, annular | 121 Screw, pan head, 4-40 x 5/16 |
| 30 E-ring, 0.180 ID | 75 Nut, sleeve, no. 1 | 122 Stub shaft |
| 31 Bearing, ball, annular | 76 Bearing, ball, annular | 123 Gear and Stop Assy, no. 2 |
| 32 C-ring, 0.160 ID | 77 C-ring, 0.160 ID | 124 E-ring, 0.180 ID |
| 33 C-ring, 0.160 ID | 78 Gearshaft Assy, 10- and 100-kHz | 125 Gear and Stop Assy, no. 1 |
| 34 Bearing, ball, annular | 79 Bearing, ball, annular | 126 Setscrew, 6-40 x 1/8 |
| 35 Stub shaft | 80 Gasket, O-ring | 127 Gearshaft, spur no. 2 |
| 36 Gear stop (refer only) | 81 Bearing, sleeve, nylon | 128 Gearshaft-coupler Assy |
| 37 Gear and Stop Assy, idler | 82 Washer, flat, 0.190 ID | 129 Washer, lock, #4 |
| 38 E-ring, 0.180 ID | 83 Collar, shaft | 130 Screw, pan head, 4-40 x 5/16 |
| 39 Nut, sleeve, no. 1 | 84 Washer, lock, #6 | 131 Clamp, cable |
| 40 Bearing, sleeve, nylon | 85 Nut, hex, 6-32 | 132 Washer, flat, #6 |
| 41 Spur gear | 86 Setscrew, 8-32 x 1/8 | 133 Washer, lock, #6 |
| 42 Nut, sleeve, no. 2 | 87 Screw, eye, 6-32 | 134 Screw, pan head, 6-32 x 3/8 |
| 43 Spur gear, idler | 88 Bearing, sleeve, nylon | 135 Coupling-half, Shaft no. 3 |
| 44 E-ring, 0.180 ID | 89 E-ring, 0.180 ID | 136 Washer, lock, #6 |
| 45 Shaft, switch, fiber | 90 Bearing, sleeve, nylon | 137 Screw, pan head, 6-32 x 3/8 |
| 45A Bearing, sleeve, nylon | 91 Detent, spur gear | 138 Washer, lock, #6 |
| | 92 Collar, shaft | 139 Nut, hex, 6-32 |

TM5820-509-35-105

Figure 3-90 Radio Receiver - Transmitter RT-671/PRC-47. Frequency Selection Mechanism (A8A4.A1) Exploded View.

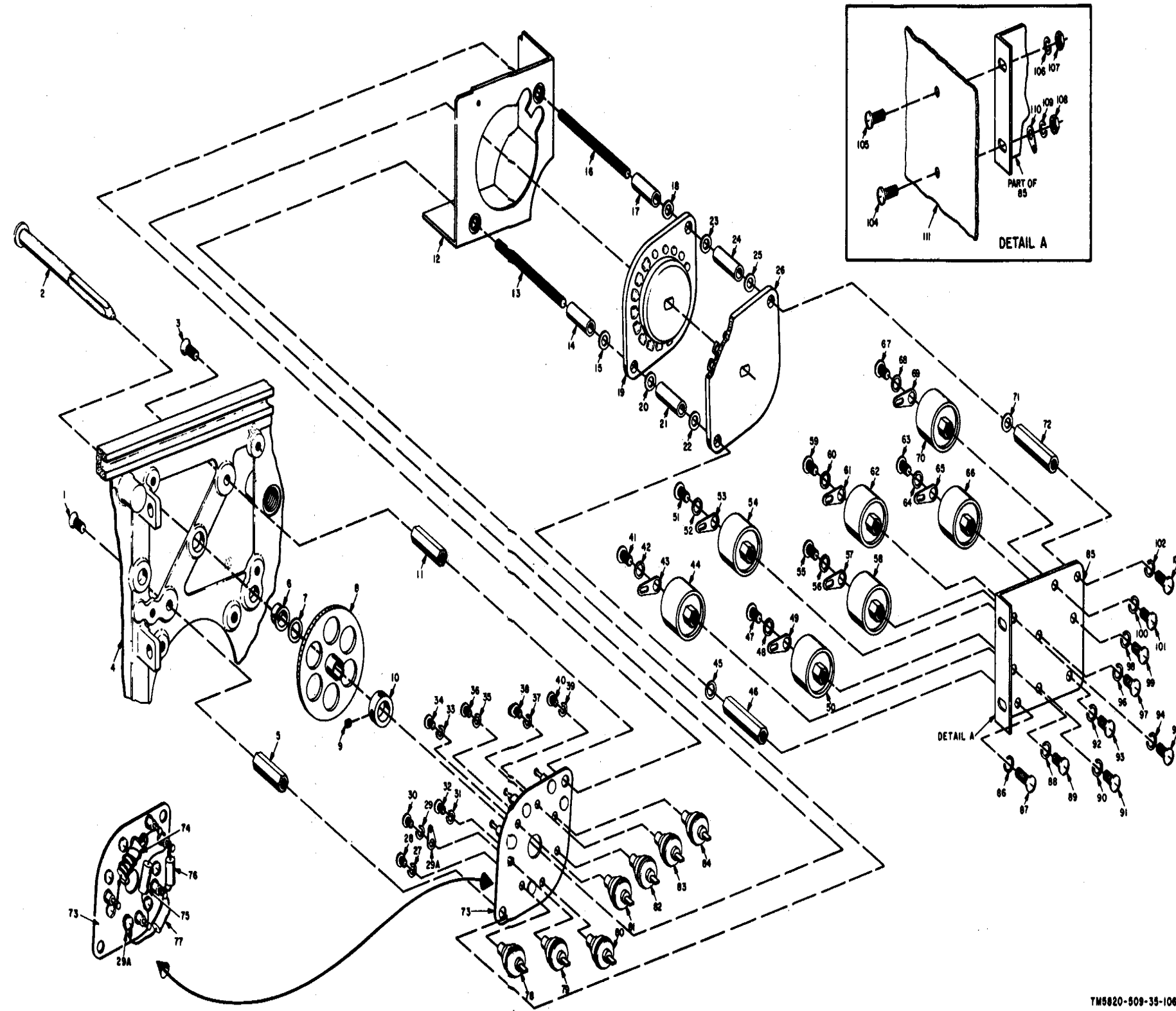

LEGEND FOR FIGURE 3-91

- | | | |
|------------------------------------|------------------------------------|-----------------------------------|
| 1 Screw, flat head, 6-32 x 1/4 | 38 Screw, pan head, 3-48 x 3/16 | 76 Capacitor (C105) |
| 2 Shaft, fiber, switch | 39 Washer, lock, #3 | 77 Capacitor (C144) |
| 3 Screw, flat head, 6-32 x 12 | 40 Screw, pan head, 3-48 x 3/16 | 78 Capacitor (C111) |
| 4 Front panel, RT-671/PRC-47 | 41 Screw, pan head, 6-32 x 3/16 | 79 Capacitor (C110) |
| 5 Nut, sleeve, no. 1 | 42 Washer, flat, #6 | 80 Capacitor (C112) |
| 6 Bearing, sleeve, nylon | 43 Lug, soldering | 81 Capacitor (C109) |
| 7 Washer, flat, 1/4 ID | 44 Capacitor (C121) | 82 Capacitor (C114) |
| 8 Spur gear, switch drive | 45 Washer, fiber, 5/32 ID x 3/8 OD | 83 Capacitor (C108) |
| 9 Setscrew, 6-32 x 1/8 | 46 Nut, sleeve, no. 2 | 84 Capacitor (C113) |
| 10 Collar, shaft | 47 Screw, pan head, 6-32 x 3/16 | 85 Bracket, capacitor mounting |
| 11 Nut, sleeve, no. 1 | 48 Washer, flat, #6 | 86 Washer, lock, #6 |
| 12 Deflector, air | 49 Lug, soldering | 87 Screw pan head, 6-32 x 3/8 |
| 13 Stud, 6-32 x 2 1/4 | 50 Capacitor, (C119) | 88 Washer, lock, #6 |
| 14 Spacer, sleeve, no. 1 | 51 Screw, pan head, 6-32 x 3/16 | 89 Screw, pan head, 6-32 x 1/4 |
| 15 Washer, fiber, 5/32 ID x 3/8 OD | 52 Washer, flat, #6 | 90 Washer, lock, #6 |
| 16 Stud, 6-32 x 2 1/4 | 53 Lug, soldering | 91 Screw, pan head, 6-32 x 1/4 |
| 17 Spacer, sleeve, no. 1 | 54 Capacitor, (C120) | 92 Washer, lock, #6 |
| 18 Washer, fiber, 5-32 ID x 3/8 OD | 55 Screw, pan head, 6-32 x 3/16 | 93 Screw, pan head, 6-32 x 1/4 |
| 19 Switch wafer, front | 56 Washer, flat, #6 | 94 Washer, lock, #6 |
| 20 Washer, fiber, 5/32 ID x 3/8 OD | 57 Lug, soldering | 95 Screw, pan head, 6-32 x 1/4 |
| 21 Spacer, sleeve, no. 2 | 58 Capacitor, (C115) | 96 Washer, lock, #6 |
| 22 Washer, fiber, 5/32 ID x 3/8 OD | 59 Screw, pan head, 6-32 x 3/16 | 97 Screw, pan head, 6-32 x 1/4 |
| 23 Washer, fiber, 5/32 ID x 3/8 OD | 60 Washer, flat, #6 | 98 Washer, lock, #6 |
| 24 Spacer, sleeve, no. 2 | 61 Lug, soldering | 99 Screw, pan head, 6-32 x 1/4 |
| 25 Washer, fiber, 5/32 ID x 3/8 OD | 62 Capacitor, (C116) | 100 Washer, lock, #6 |
| 26 Switch wafer, rear | 63 Screw, pan head, 6-32 x 3/16 | 101 Screw, pan head, 6-32 x 1/4 |
| 27 Washer, lock, #3 | 64 Washer, flat, #6 | 102 Washer, lock, #6 |
| 28 Screw, pan head, 3-48 x 3/16 | 65 Lug, soldering | 103 Screw, pan head, 6-32 x 3/8 |
| 29 Washer, lock, #3 | 66 Capacitor, (C118) | 104 Screw, flat head, 4-40 x 5/16 |
| 29A. Lug, soldering, ground | 67 Screw, pan head, 6-32 x 3/16 | 106 Screw, flat head, 4-40 x 5/16 |
| 30 Screw, pan head, 3-48 x 3/16 | 68 Washer, flat, #6 | 106 Washer, lock, #4 |
| 31 Washer, lock, #3 | 69 Lug, soldering | 107 Nut, hex, 4-40 |
| 32 Screw, pan head, 3-48 x 3/16 | 70 Capacitor, (C117) | 108 Nut, hex, 4-40 |
| 33 Washer, lock, #3 | 71 Washer, fiber, 5/32 ID x 3/8 OD | 109 Washer, lock, #4 |
| 34 Screw, pan head, 3-48 x 3/16 | 72 Nut, sleeve, no. 2 | 110 Lug, soldering |
| 35 Washer, lock, #3 | 73 Plate, capacitor mounting | 111 Side, PA compartment |
| 36 Screw, pan head, 3-48 x 3/16 | 74 Suppressor, (L104-R110) | |
| 37 Washer, lock, #3 | 75 Capacitor (C124) | |

TM 11-5820-509-35-106

Figure 3-91. Radio Receiver - Transmitter RT-671/PRC-47, Power Amplifier Compartment (A8A4A1) Plat Capacitor Switch, Exploded View.

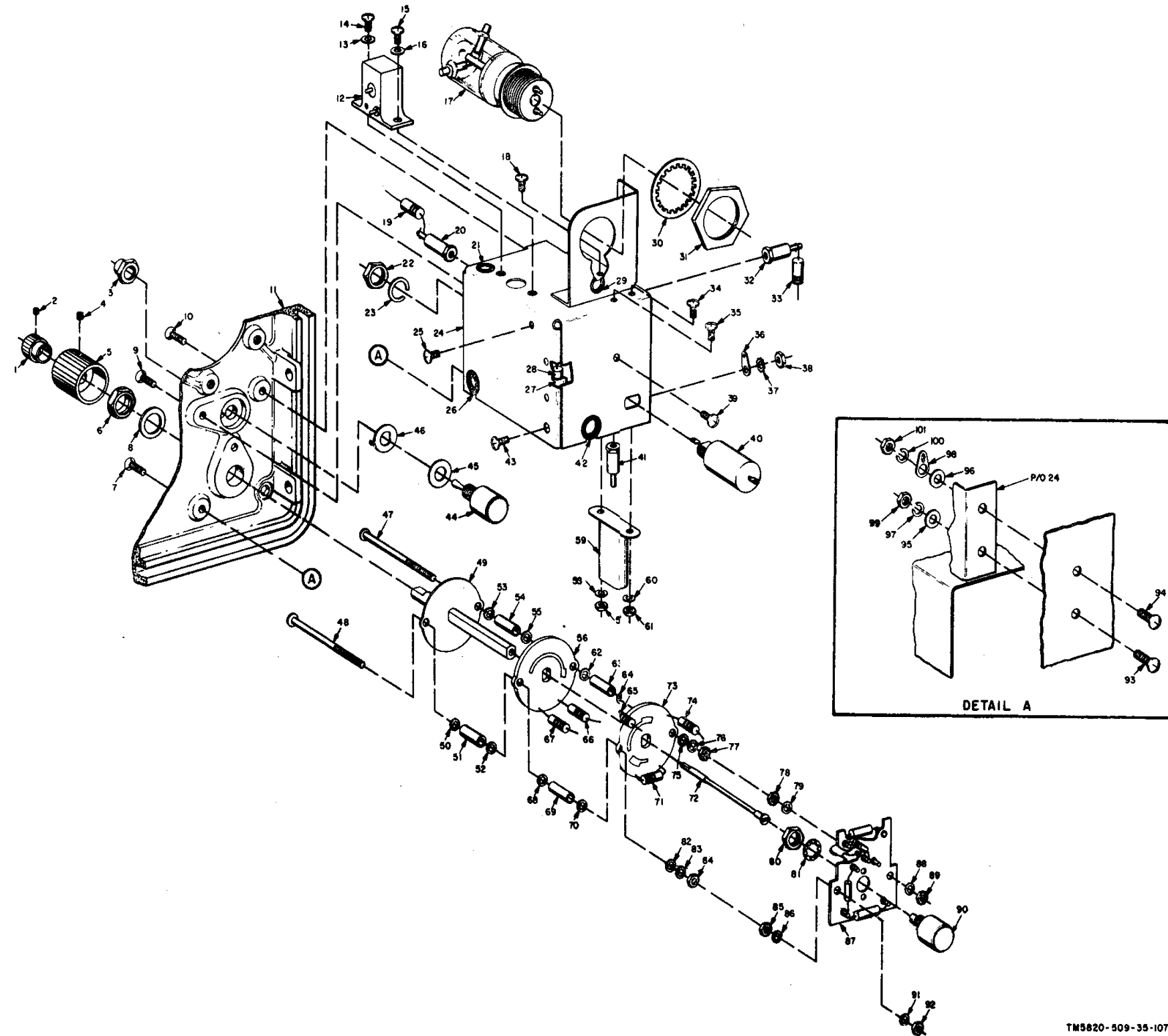

LEGEND FOR FIGURE 3-92

- | | | |
|---------------------------------|------------------------------------|---------------------------------|
| 1 Knob, M ADJ | 34 Screw, pan head, 4-40 x 1/4 | 68 Washer, fiber, #4 |
| 2 Setscrew, 4-48 x 1/8 | 35 Screw, pan head, 4-40 x 1/4 | 69 Spacer, sleeve, no. 2 |
| 3 Boot, toggle switch, 1/4-40 | 36 Lug, soldering | 70 Washer, fiber, #4 |
| 4 Set screw, 6-32 x 1/8 | 37 Washer, lock, #6 | 71 Resistor, (R107) |
| 5 Knob, large, (XMTR PWR) | 38 Nut, hex, 6-32 | 72 Shaft, potentiometer |
| 6 Nut, hex, 3/8-32 | 39 Screw, pan head, 4-40 x 1/4 | 73 Switch wafer, (S103B) |
| 7 Screw, flat head, 6-32 x 1/2 | 40 Capacitor, (C146) | 74 Resistor, (R118) |
| 8 Washer, flat, 3/8 ID | 41 Terminal, stud | 75 Washer, fiber, #4 |
| 9 Screw, flat head, 6-32 x 1/2 | 42 Grommet, rubber | 76 Washer, flat, #4 |
| 10 Screw, flat head, 6-32 x 1/2 | 43 Screw, pan head, 6-32 x 1/4 | 77 Nut, hex, 4-40 |
| 11 Panel, front | 44 Switch, toggle, (OPR-TUNE) | 78 Nut, hex, 4-40 |
| 12 Transformer, rf, (T101) | 45 Washer, flat, 1/4 | 79 Washer, flat, #4 |
| 13 Washer, flat, #4 | 46 Washer, lock ring, 1/4 | 80 Nut, hex, 1/4-32 |
| 14 Screw, pan head, 4-40 x 5/16 | 47 Screw, round head, 4-40 x 2 1/4 | 81 Washer, lock, 3/8 |
| 15 Screw, pan head, 4-40 x 5/16 | 48 Screw, round head, 4-40 x 2 1/4 | 82 Washer, fiber, #4 |
| 16 Washer, flat, #4 | 49 Detent, switch | 83 Washer, flat, #4 |
| 17 Relay, vacuum (K101) | 50 Washer, fiber, #4 | 84 Nut, hex, 4-40 |
| 18 Screw, pan head, 4-40 x 1/4 | 51 Spacer, sleeve, no. 1 | 85 Nut, hex, 4-40 |
| 19 Resistor, (R120) | 52 Washer, fiber, #4 | 86 Washer, flat, #4 |
| 20 Terminal, stud | 53 Washer, fiber, #4 | 87 Resistor-switch subassembly |
| 21 Grommet, rubber | 54 Spacer, sleeve, no. 1 | 88 Washer, flat, #4 |
| 22 Nut, hex, 5/16-24 | 55 Washer, fiber, #4 | 89 Nut, hex, 4-40 |
| 23 Washer, lock, 5/16 | 56 Switch wafer, (S103A) | 90 Potentiometer, (M ADJ) |
| 24 Bracket, relay | 57 Nut, hex, 4-40 | 91 Washer, flat, #4 |
| 25 Screw, pan head, 4-40 x 1/4 | 58 Washer, lock, #4 | 92 Nut, hex, 4-40 |
| 26 Grommet, rubber | 59 Relay, armature, (K102) | 93 Screw, pan head, 4-40 x 5/16 |
| 27 Clip, electrical component | 60 Washer, lock, #4 | 94 Screw, pan head, 4-40 x 5/16 |
| 28 Capacitor, (C145) | 61 Nut, hex, 4-40 | 95 Washer, flat, #4 |
| 29 Grommet, rubber | 62 Washer, fiber, #4 | 96 Washer, flat, #4 |
| 30 Washer, lock, 13/16 | 63 Spacer, sleeve, no. 2 | 97 Washer, lock, #4 |
| 31 Nut, hex, 13/16-32 | 64 Washer, fiber, #4 | 98 Lug, soldering |
| 32 Terminal, stud | 65 Resistor, (R106) | 99 Nut, hex, 4-40 |
| 33 Resistor, (R125) | 66 Resistor, (R128) | 100 Washer, lock, #4 |
| | 67 Resistor, (R105) | 101 Nut, hex, 4-40 |

Figure 3-92. Radio Receiver - Transmitter RT671/PRC-47, Power Amplifier Compartment (A84A1) XMTR PWR Switch (S103), Exploded View.

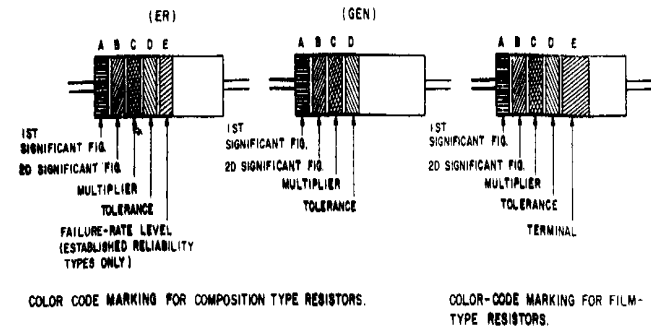

TABLE 1
COLOR CODE FOR COMPOSITION TYPE AND FILM TYPE RESISTORS.

BAND A		BAND B		BAND C		BAND D		BAND E	
COLOR	FIRST SIGNIFICANT FIGURE	COLOR	SECOND SIGNIFICANT FIGURE	COLOR	MULTIPLIER	COLOR	RESISTANCE TOLERANCE (PERCENT)	COLOR	FAILURE RATE LEVEL
BLACK	0	BLACK	0	BLACK	1	BROWN	M±0	BROWN	M±0
BROWN	1	BROWN	1	BROWN	10	RED	P±0.1	RED	P±0.1
RED	2	RED	2	RED	100	ORANGE	R±0.01	ORANGE	R±0.01
ORANGE	3	ORANGE	3	ORANGE	1,000	YELLOW	S±0.001	YELLOW	S±0.001
YELLOW	4	YELLOW	4	YELLOW	10,000	SILVER	±10 (COMP TYPE ONLY)	WHITE	SOLD-ERABLE
GREEN	5	GREEN	5	GREEN	100,000	GOLD	±5		
BLUE	6	BLUE	6	BLUE	1,000,000	RED	±2 (NOT APPLICABLE TO ESTABLISHED RELIABILITY)		
PURPLE (VIOLET)	7	PURPLE (VIOLET)	7						
GRAY	8	GRAY	8	SILVER	0.01				
WHITE	9	WHITE	9	GOLD	0.1				

BAND A — THE FIRST SIGNIFICANT FIGURE OF THE RESISTANCE VALUE (BANDS A THRU D SHALL BE OF EQUAL WIDTH.)
 BAND B — THE SECOND SIGNIFICANT FIGURE OF THE RESISTANCE VALUE.
 BAND C — THE MULTIPLIER (THE MULTIPLIER IS THE FACTOR BY WHICH THE TWO SIGNIFICANT FIGURES ARE MULTIPLIED TO YIELD THE NOMINAL RESISTANCE VALUE.)
 BAND D — THE RESISTANCE TOLERANCE.
 BAND E — WHEN USED ON COMPOSITION RESISTORS, BAND E INDICATES ESTABLISHED RELIABILITY FAILURE-RATE LEVEL (PERCENT FAILURE PER 1,000 HOURS); ON FILM RESISTORS, THIS BAND SHALL BE APPROXIMATELY 1/2 TIMES THE WIDTH OF OTHER BANDS AND INDICATES TYPE OF TERMINAL.

RESISTANCES IDENTIFIED BY NUMBERS AND LETTERS (THESE ARE NOT COLOR CODED)
 SOME RESISTORS ARE IDENTIFIED BY THREE OR FOUR DIGIT ALPHA NUMERIC DESIGNATORS. THE LETTER R IS USED IN PLACE OF A DECIMAL POINT WHEN FRACTIONAL VALUES OF AN OHM ARE EXPRESSED. FOR EXAMPLE:
 2R7 = 2.7 OHMS 10R0 = 10.0 OHMS

FOR WIRE-WOUND-TYPE RESISTORS COLOR CODING IS NOT USED, IDENTIFICATION MARKING IS SPECIFIED IN EACH OF THE APPLICABLE SPECIFICATIONS.

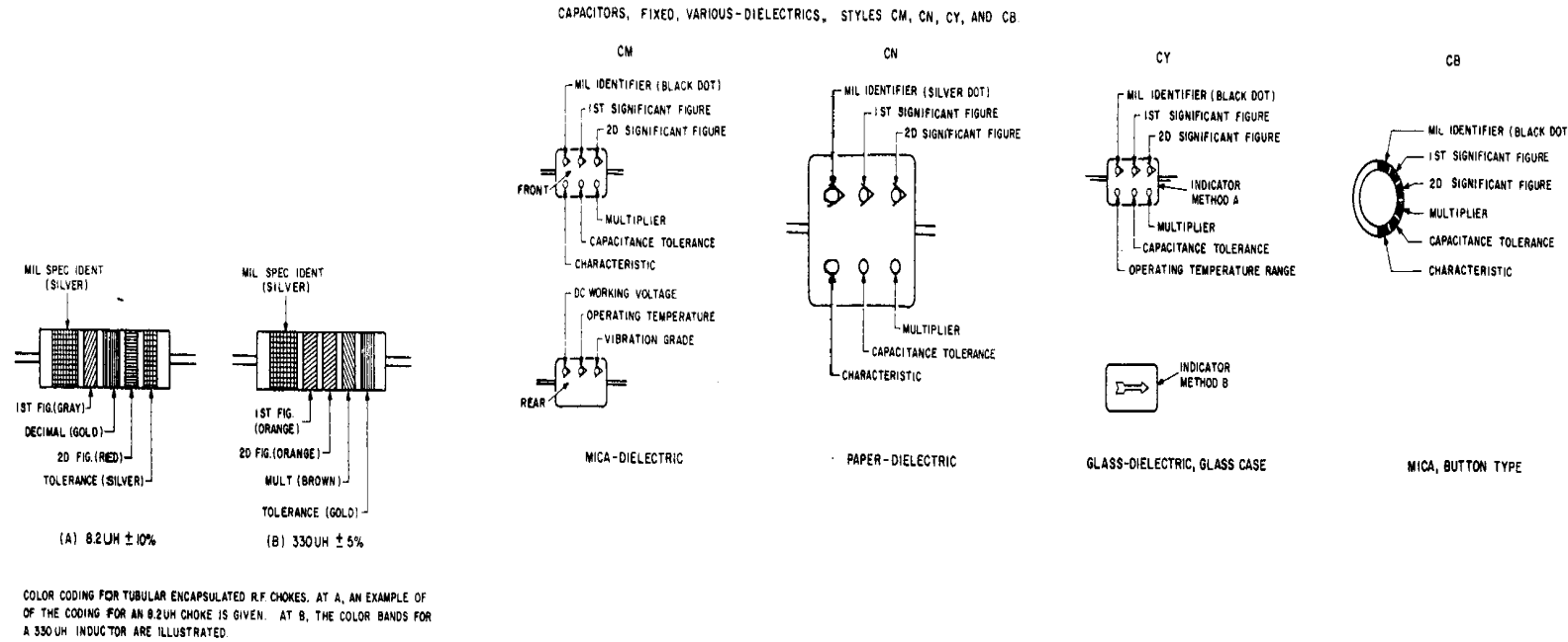
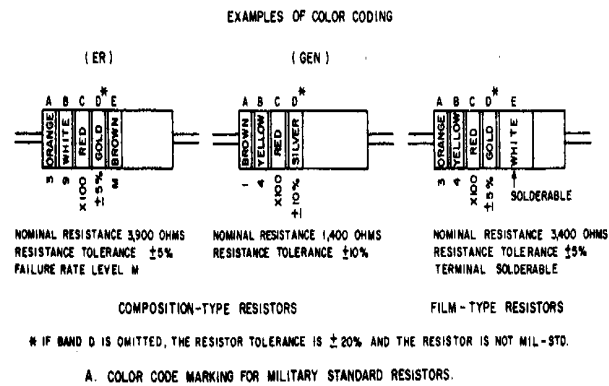

TABLE 2
COLOR CODING FOR TUBULAR ENCAPSULATED R.F. CHOKES

COLOR	SIGNIFICANT FIGURE	MULTIPLIER	INDUCTANCE TOLERANCE (PERCENT)
BLACK	0	1	
BROWN	1	10	1
RED	2	100	2
ORANGE	3	1,000	3
YELLOW	4		
GREEN	5		
BLUE	6		
VIOLET	7		
GRAY	8		
WHITE	9		
NONE			20
SILVER			10
GOLD			5

MULTIPLIER IS THE FACTOR BY WHICH THE TWO COLOR FIGURES ARE MULTIPLIED TO OBTAIN THE INDUCTANCE VALUE OF THE CHOKE COIL.

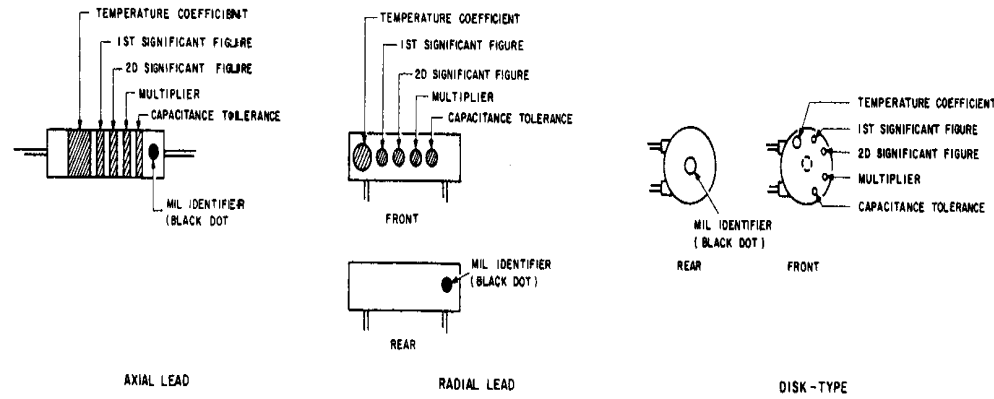

TABLE 3 — FOR USE WITH STYLES CM, CN, CY AND CB

COLOR	MIL ID	1ST SIG FIG	2D SIG FIG	MULTIPLIER	CAPACITANCE TOLERANCE				CHARACTERISTIC	DC WORKING VOLTAGE	OPERATING TEMP RANGE	VIBRATION GRADE
					CM	CN	CY	CB				
BLACK	CM, CY, CB	0	0	1					A		-55° to +70°C	10-55 HZ
BROWN		1	1	10					B	E		
RED		2	2	100	±2%				C		-55° to +85°C	
ORANGE		3	3	1,000	±30%				D	D	300	
YELLOW		4	4	10,000					E		-55° to +25°C	10-2,000 HZ
GREEN		5	5						F		500	
BLUE		6	6								-55° to +50°C	
PURPLE (VIOLET)		7	7									
GRAY		8	8									
WHITE		9	9									
GOLD				0.1	±5%	±5%						
SILVER	CN			0.01	±10%	±10%	±10%					

TABLE 4 — TEMPERATURE COMPENSATING, STYLE CC

COLOR	TEMPERATURE COEFFICIENT*	1ST SIG FIG	2D SIG FIG	MULTIPLIER	CAPACITANCE TOLERANCE	MIL
					CAPACITANCES OVER 10 UUF	CAPACITANCES 10 UUF OR LESS
BLACK	0	0	0	1		±20 UUF CC
BROWN	-30	1	1	10	±1%	
RED	-80	2	2	100	±2%	±0.25 UUF
ORANGE	-150	3	3	1,000		
YELLOW	-220	4	4			
GREEN	-330	5	5		±5%	±0.5 UUF
BLUE	-470	6	6			
PURPLE (VIOLET)	-750	7	7			
GRAY		8	8	0.01*		
WHITE		9	9	0.1*	±10%	
GOLD	+100			0.1		±1.0 UUF
SILVER				0.01		

- THE MULTIPLIER IS THE NUMBER BY WHICH THE TWO SIGNIFICANT (SIG) FIGURES ARE MULTIPLIED TO OBTAIN THE CAPACITANCE IN UUF.
- LETTERS INDICATE THE CHARACTERISTICS DESIGNATED IN APPLICABLE SPECIFICATIONS: MIL-C-5, MIL-C-250, MIL-C-11272B, AND MIL-C-10950C RESPECTIVELY.
- LETTERS INDICATE THE TEMPERATURE RANGE AND VOLTAGE-TEMPERATURE LIMITS DESIGNATED IN MIL-C-11016D.
- TEMPERATURE COEFFICIENT IN PARTS PER MILLION PER DEGREE CENTIGRADE.
- OPTIONAL CODING WHERE METALLIC PIGMENTS ARE UNDESIRABLE.

C. COLOR CODE MARKING FOR MILITARY STANDARD CAPACITORS.

Figure 7-1. Color Code Markings for Military Standard Resistors, Inductors, and Capacitors.

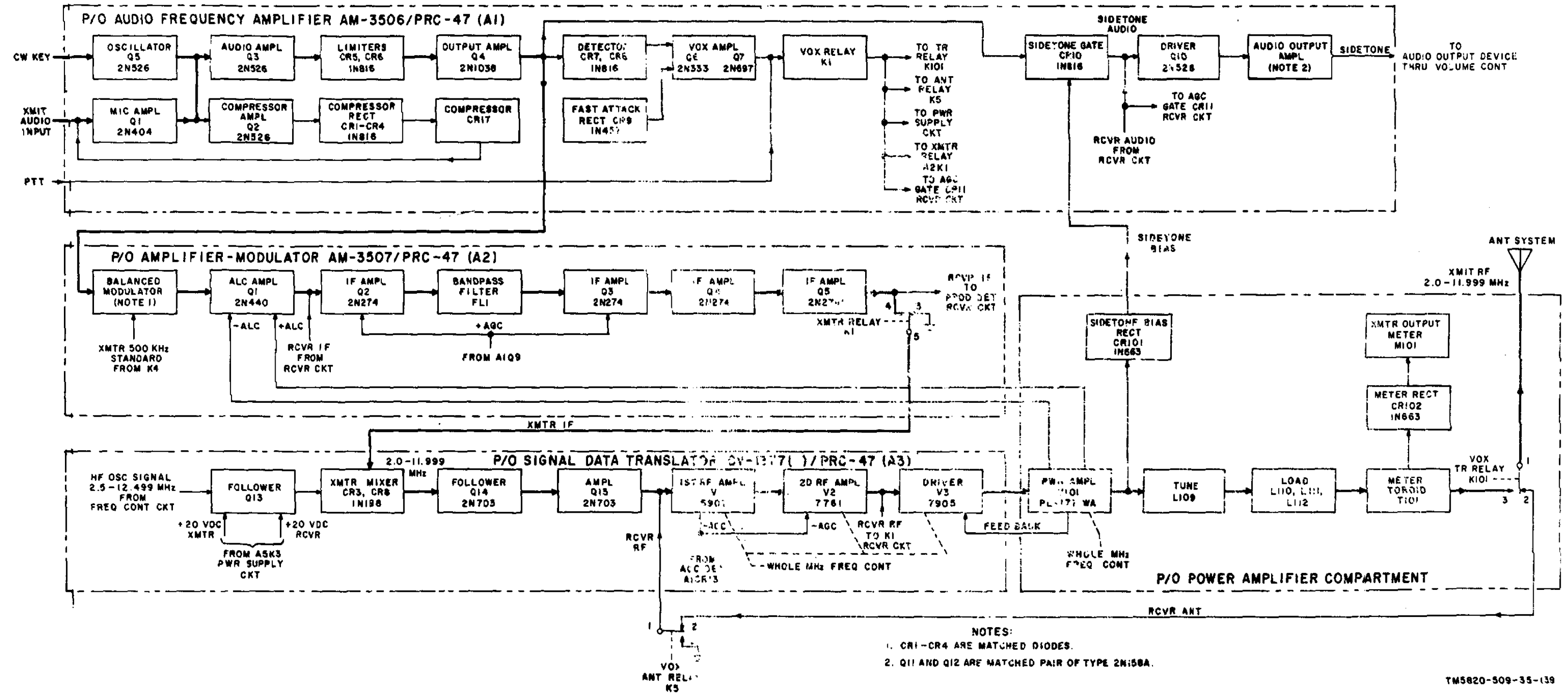

Figure 7-3. Transmit Signal Path, Block Diagram.

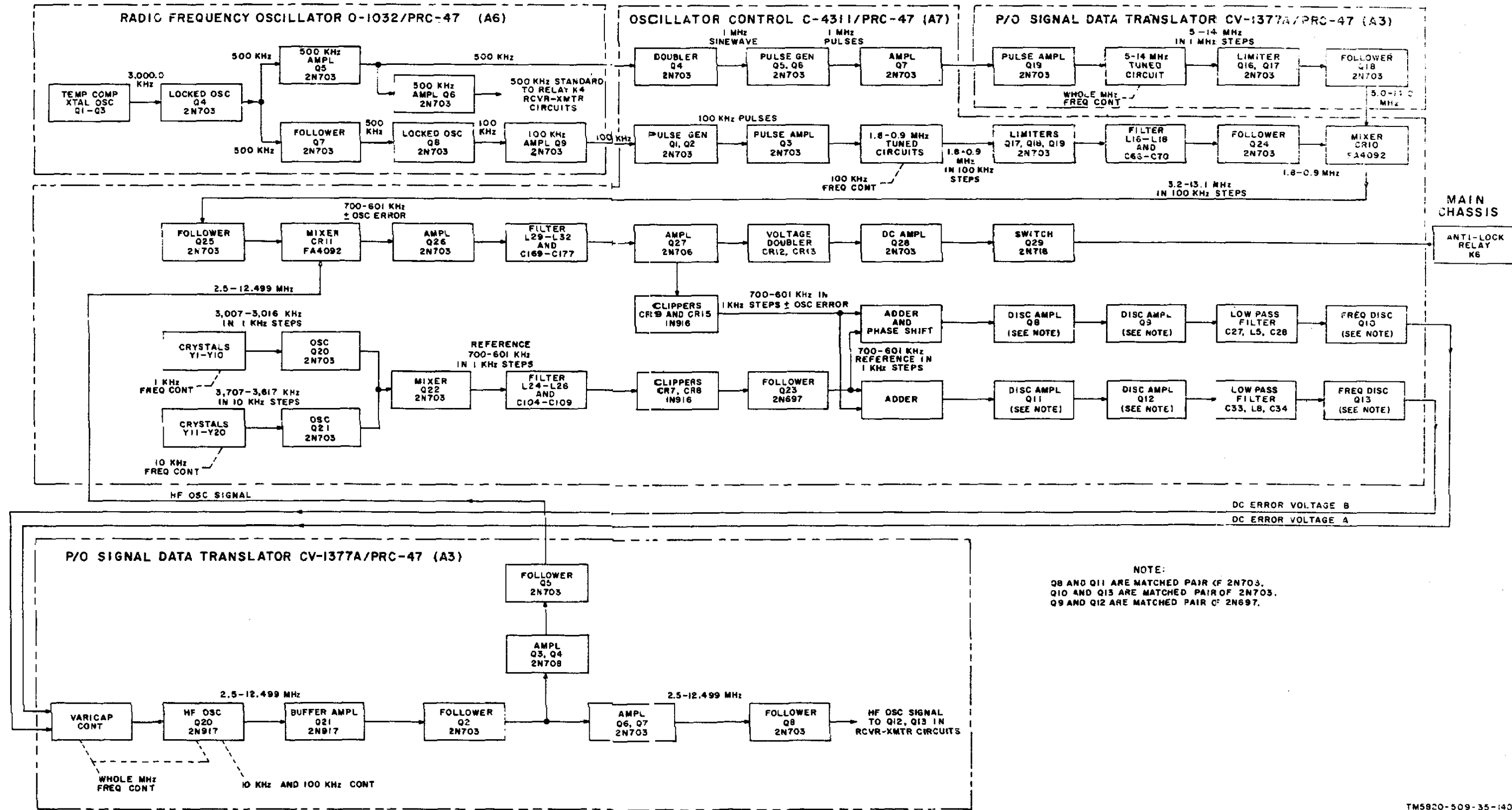
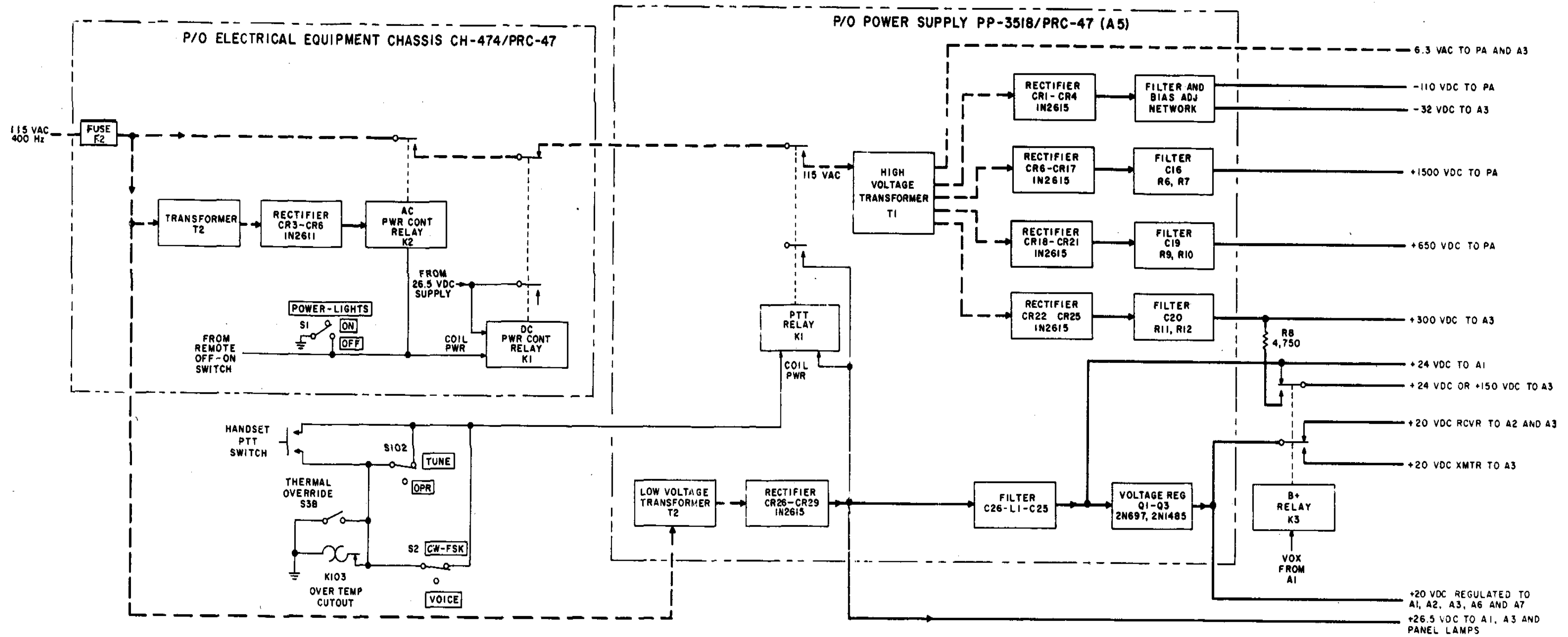

Figure 7-4. Frequency Control Circuits, Block Diagram.



NOTE:
 - - - AC SIGNAL
 ——— DC SIGNAL
 ——— CONTROL LINES

TM5820-509-35-141

Figure 7-5. Power Supply Circuits, Dc Primary Power Input, Block Diagram.

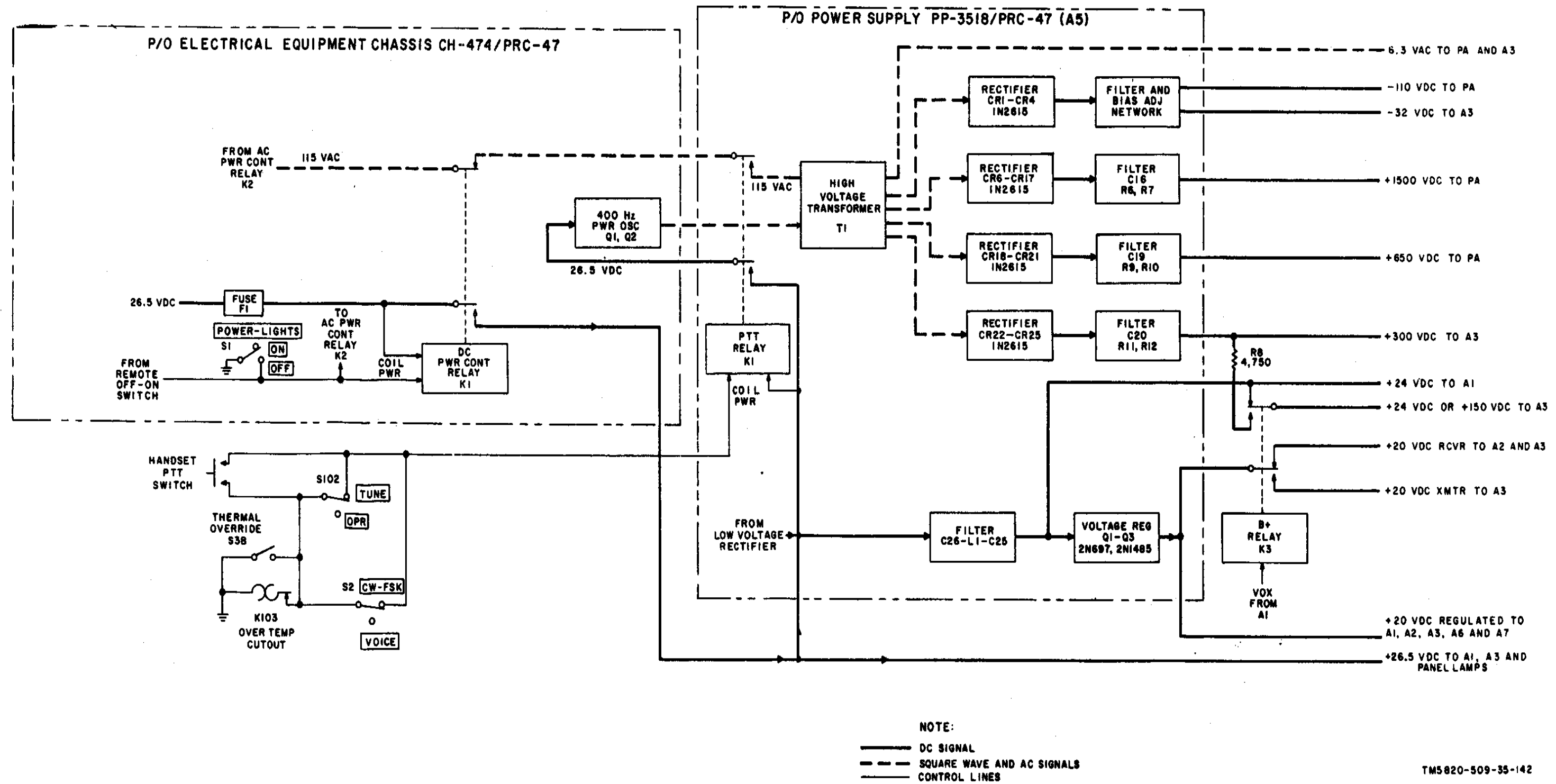

TMS820-509-35-142

Figure 7-6. Power Supply Circuits, Ac Primary Power Input, Block Diagram

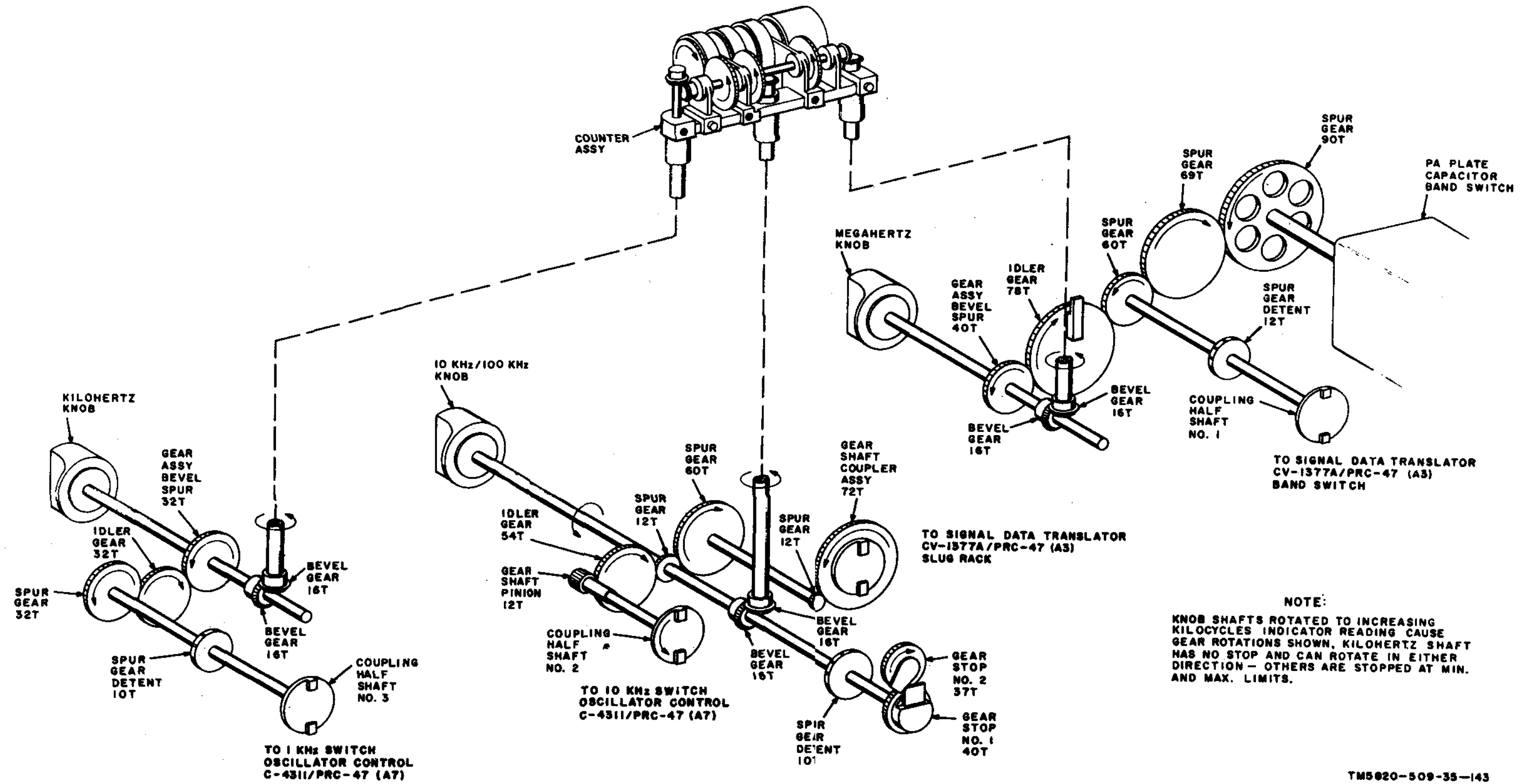

Figure 7-7. Mechanical Schematic. Frequency Control Mechanism

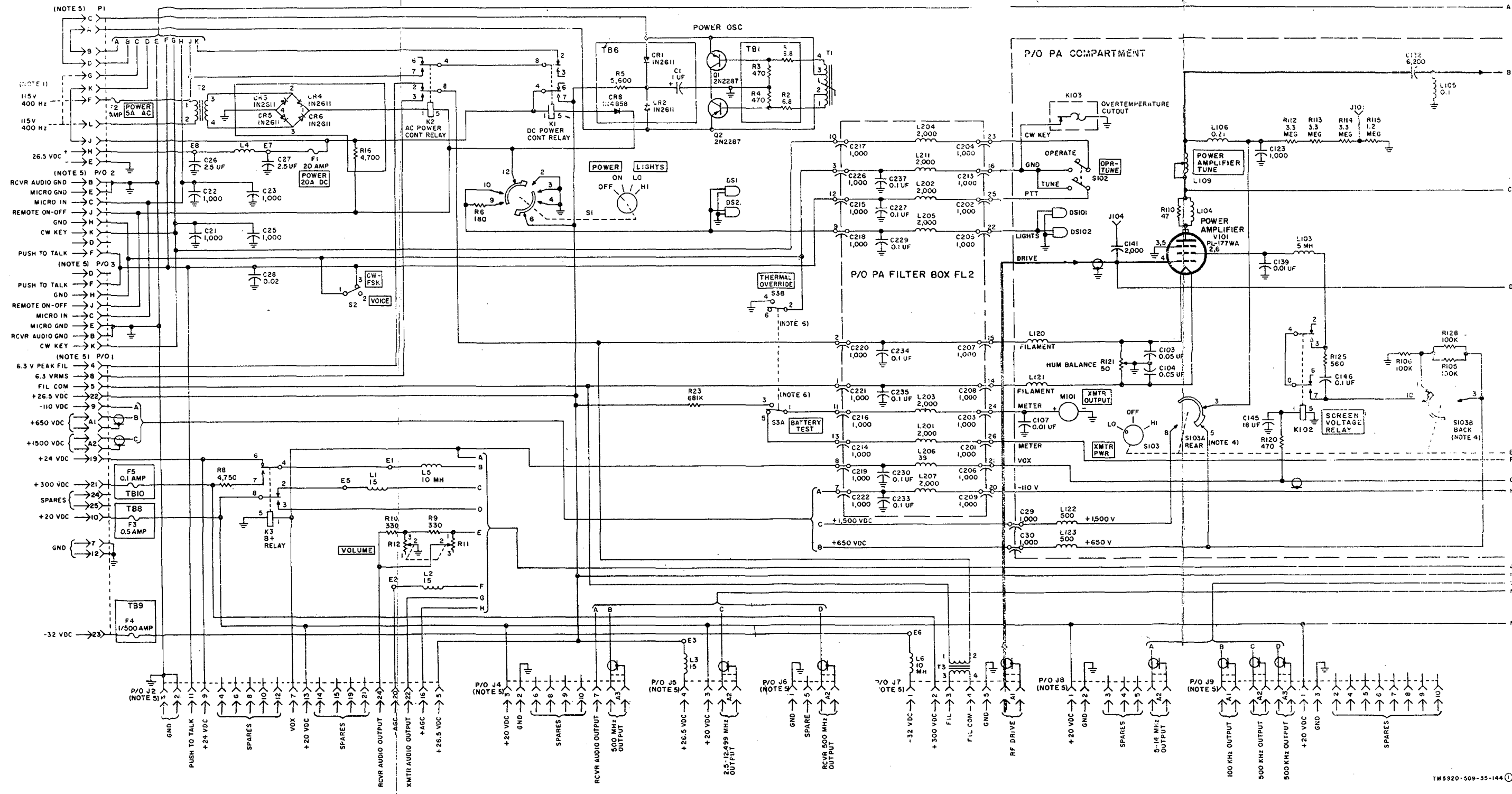

Figure 7-8 (1). Electrical Equipment Chassis CH-474/PRC-47 (A8A4), Schematic Diagram (sheet 1 of 2).

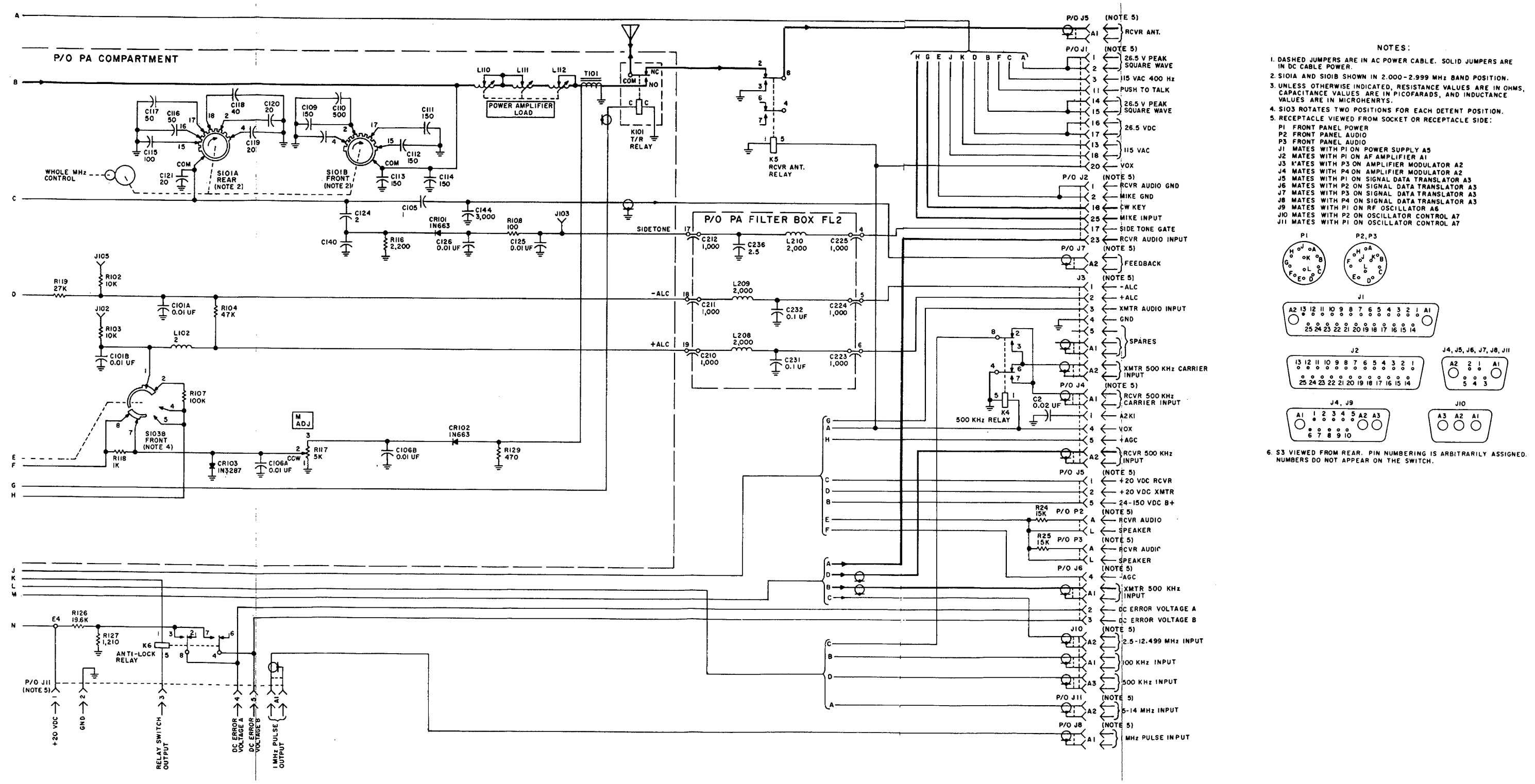

Figure 7-8 (2). Electrical Equipment Chassis CH-474/PRC-47 (A8A4), Schematic Diagram (sheet 2 of 2).

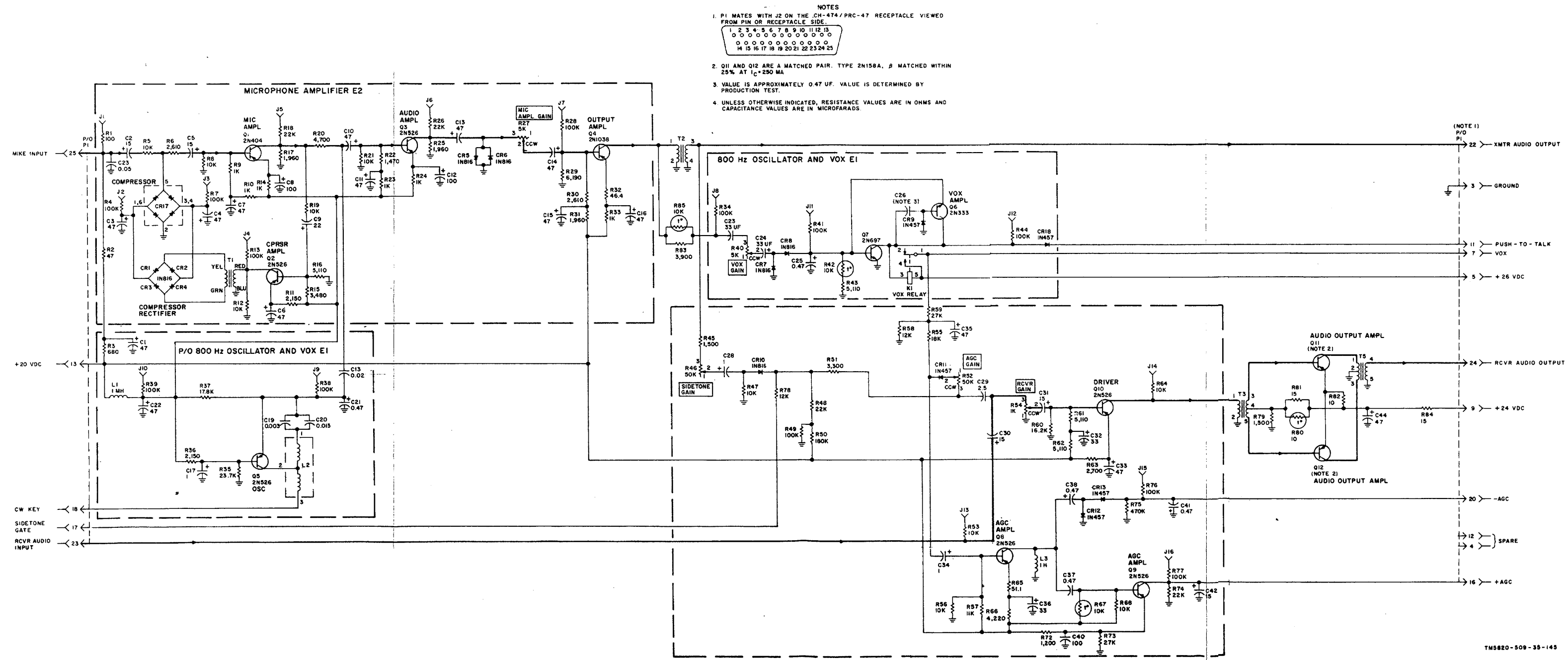

Figure 7-9. Audio Frequency Amplifier AM-3506/PRC-47 (A8A1), Schematic Diagram.

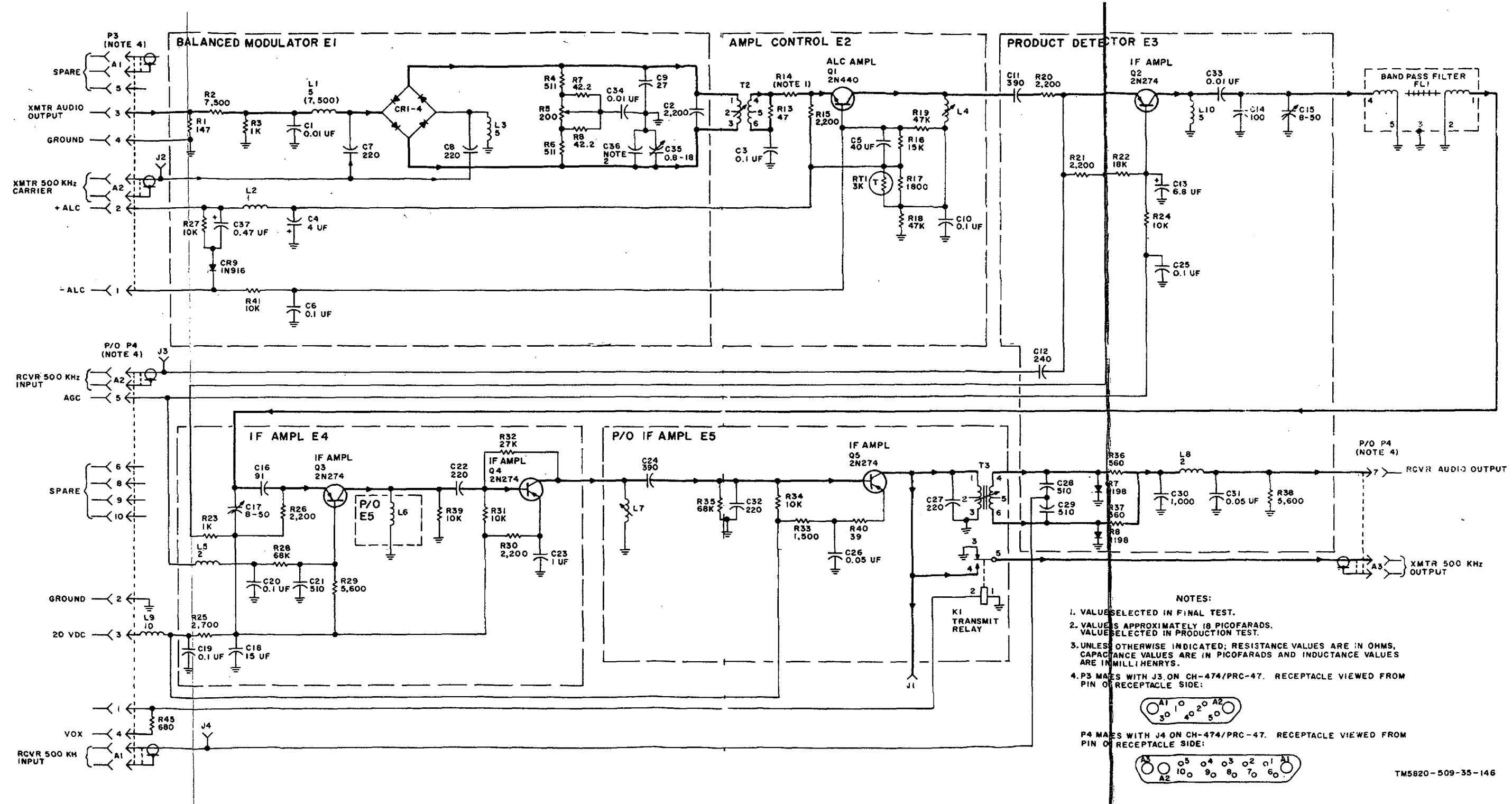

Figure 7-10. Amplifier-Modulator AM3507/PRC-47 (A8A2), Schematic Diagram.

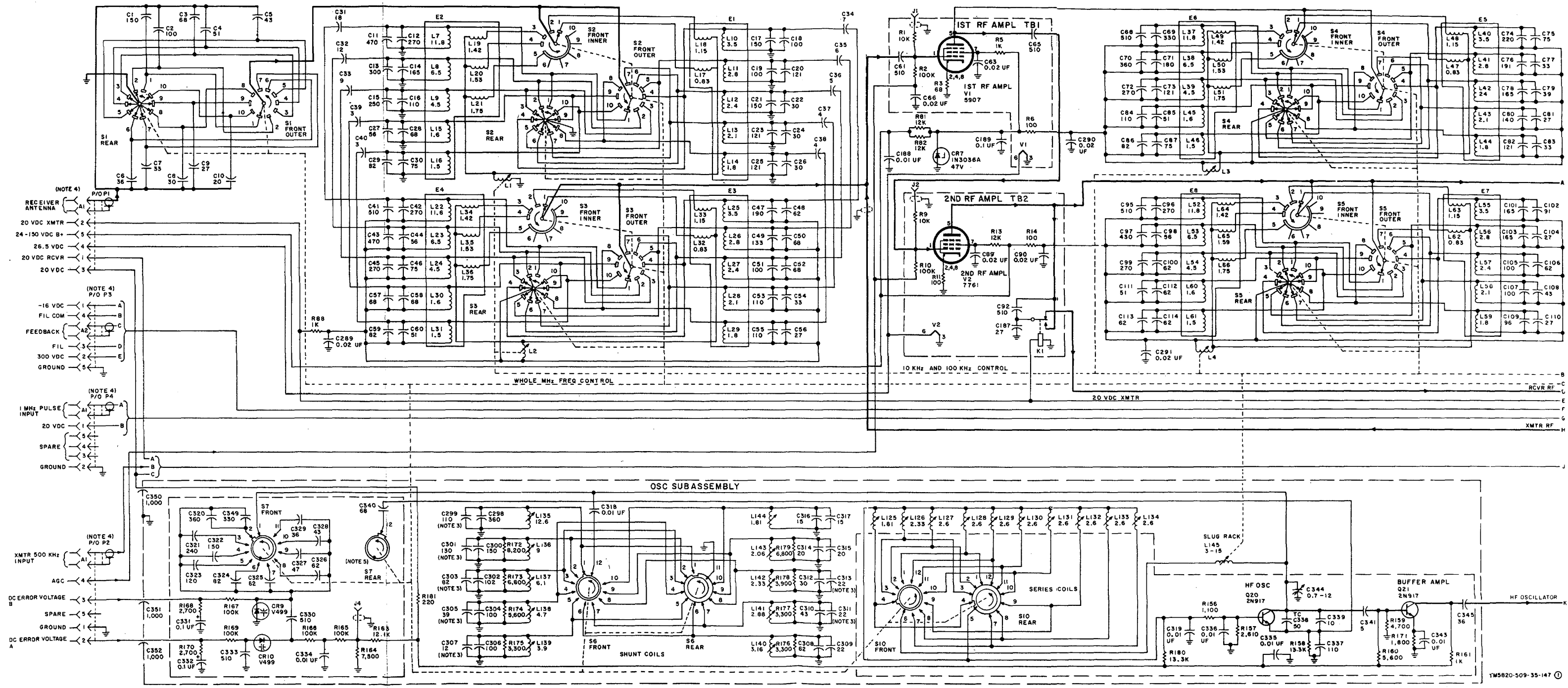

Figure 7-11 (1). Signal Data Translator CV-1377A/PRC-47 (A8A3), Schematic Diagram (sheet 1 of 2).

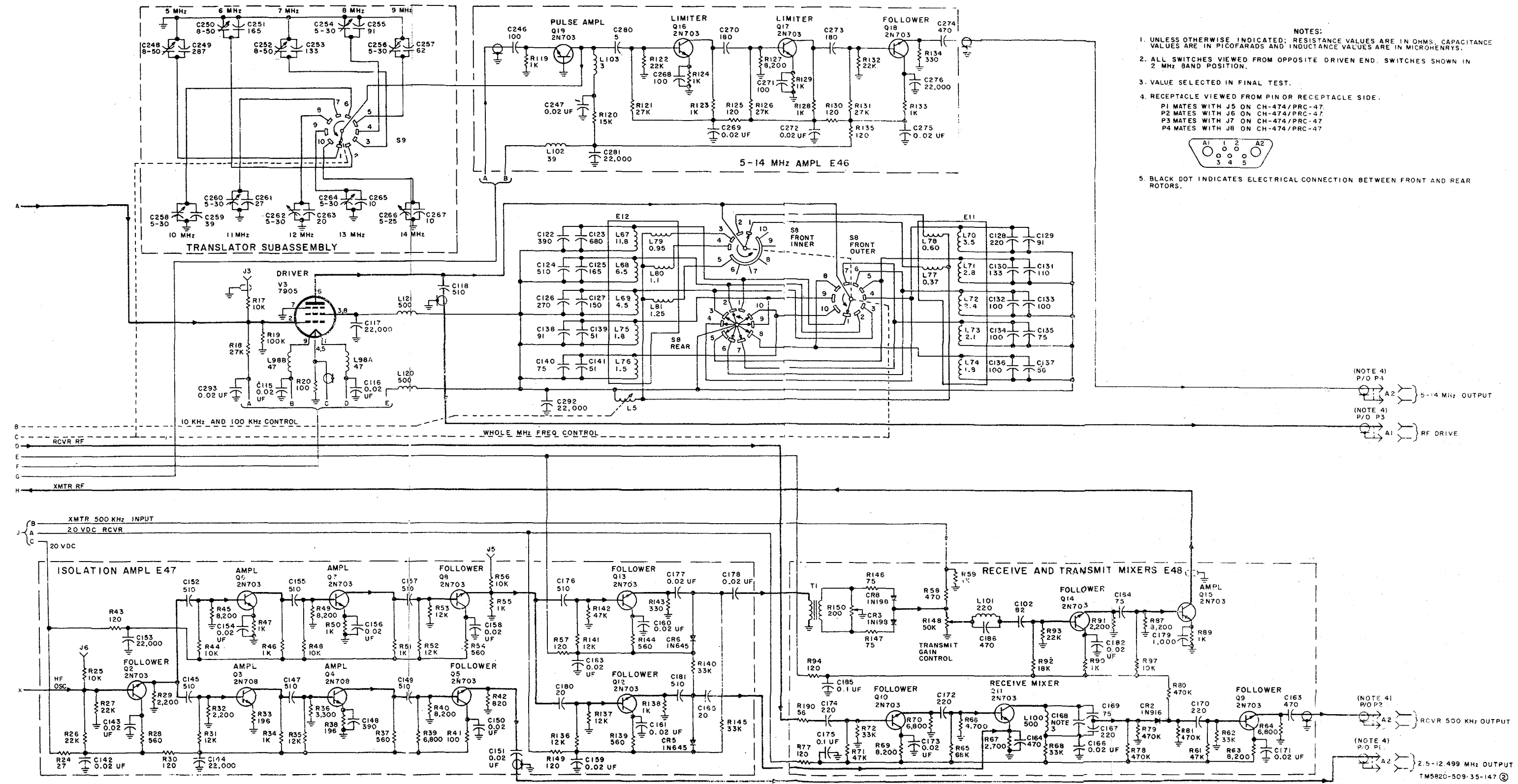
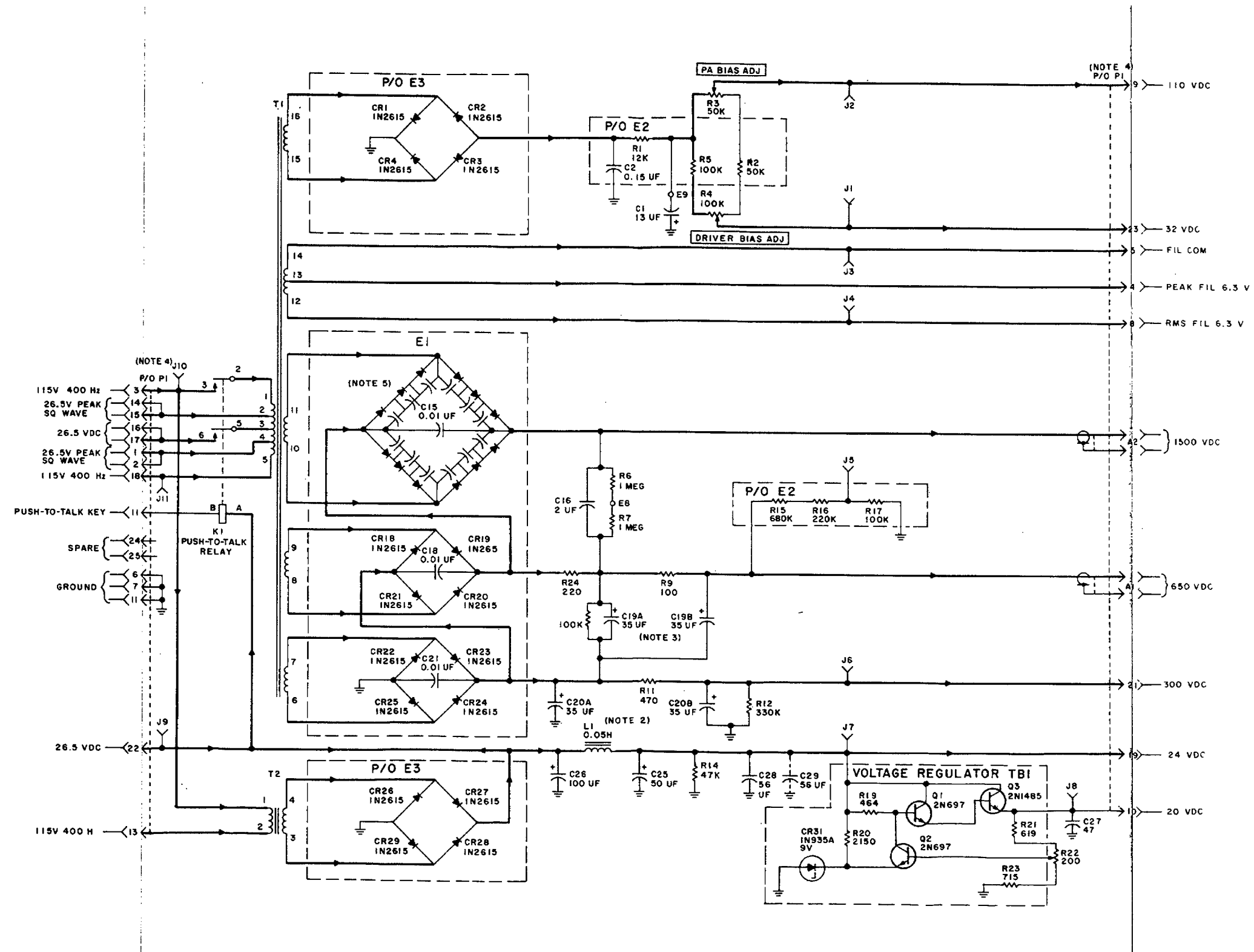

Figure 7-11 (2). Signal Data Translator CV-1377A/PRC-47 (A8A3), Schematic Diagram (sheet 2 of 2).



- NOTES:
- UNLESS OTHERWISE INDICATED, RESISTANCE VALUES ARE IN OHMS, CAPACITANCE VALUES ARE IN PICOFARADS.
 - C20A AND C20B ARE IN ONE CAN AND HAVE A COMMON GROUND.
 - C19A AND C19B ARE IN ONE CAN AND HAVE A COMMON NEGATIVE.
 - PI MATES WITH J1 ON CH-474/PRC-47, RECEPTACLE VIEWED FROM PIN OR RECEPTACLE SIDE.
-
- C3 THROUGH C14 ARE 820 PF AND CR6 THROUGH CR17 ARE 1N2615.

Figure 7-12. Power Supply PP-3518/PRC-47 (A8A5), Schematic Diagram.

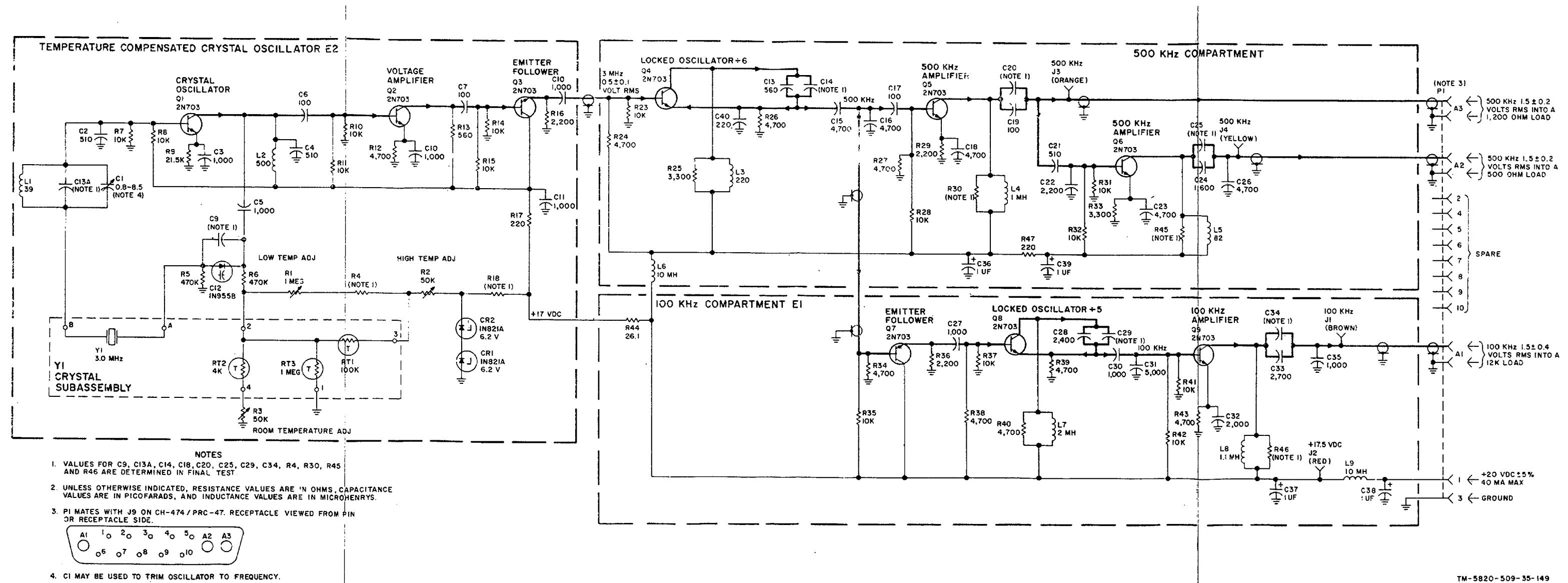
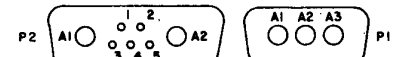

Figure 7-13. Radio Frequency Oscillator O-1032/PRC-47 (A8A6), Schematic Diagram.

- NOTES**
- VALUES ARE APPROXIMATELY 36 PF. ACTUAL VALUES ARE DETERMINED BY PRODUCTION TEST.
 - UNLESS OTHERWISE INDICATED, RESISTANCE VALUES ARE IN OHMS, CAPACITANCE VALUES ARE IN PICOFARADS AND INDUCTANCE VALUES ARE IN MICROHENRYS.
 - SWITCHES VIEWED FROM KNOB OR DRIVEN END.
 -
 - Q8 AND Q11 ARE A MATCHED PAIR. TYPE 2N703, β 40-60, MATCHED WITHIN 10% AT $V_{CE}=5V$, $I_C=0.4MA$.
Q10 AND Q13 ARE A MATCHED PAIR. TYPE 2N697, β 30-50, MATCHED WITHIN 5% AT $V_{CE}=10V$, $I_C=8MA$.
 - SELECTED IN FINAL TEST.



RECEPTACLE VIEWED FROM PIN OR RECEPTACLE SIDE.
P2 MATES WITH J10 AND P1 MATES WITH J11 ON CH-474/PRC-47

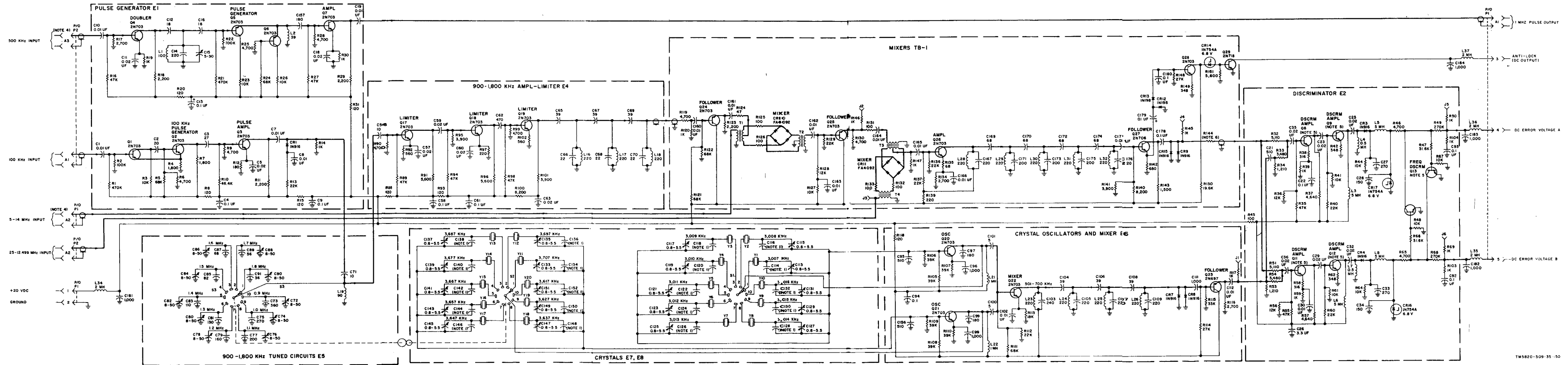

Figure 7-14. Oscillator Control C-4311/PRC-47 (A8A7), Schematic Diagram.

RECOMMENDED CHANGES TO EQUIPMENT TECHNICAL PUBLICATIONS



THEN...JOT DOWN THE DOPE ABOUT IT ON THIS FORM. CAREFULLY TEAR IT OUT, FOLD IT AND DROP IT IN THE MAIL.

SOMETHING WRONG WITH PUBLICATION

FROM: (PRINT YOUR UNIT'S COMPLETE ADDRESS)

DATE SENT

PUBLICATION NUMBER

PUBLICATION DATE

PUBLICATION TITLE

BE EXACT PIN-POINT WHERE IT IS

PAGE NO.

PARA-GRAPH

FIGURE NO.

TABLE NO.

IN THIS SPACE, TELL WHAT IS WRONG AND WHAT SHOULD BE DONE ABOUT IT.

TEAR ALONG PERFORATED LINE

PRINTED NAME, GRADE OR TITLE AND TELEPHONE NUMBER

SIGN HERE

